

THIRD EDITION

# INSECT ECOLOGY

An Ecosystem Approach



TIMOTHY D. SCHOWALTER



# **INSECT ECOLOGY**

---

*An Ecosystem Approach*

This page intentionally left blank

# INSECT ECOLOGY

---

*An Ecosystem Approach*

Third Edition

**TIMOTHY D. SCHOWALTER**

Entomology Department

LSU Agricultural Center  
Louisiana State University



*Amsterdam • Boston • Heidelberg • London  
New York • Oxford • Paris • San Diego  
• San Francisco Singapore • Sydney • Tokyo*

Academic Press is an imprint of Elsevier



Academic Press is an imprint of Elsevier  
32 Jamestown Road, London NW1 7BY, UK  
30 Corporate Drive, Suite 400, Burlington, MA 01803, USA  
525 B Street, Suite 1800, San Diego, CA 92101-4495, USA

First edition 2000  
Second edition 2006  
Third edition 2011

Copyright © 2011 Elsevier Inc. All rights reserved

No part of this publication may be reproduced, stored in a retrieval system or transmitted in any form or by any means electronic, mechanical, photocopying, recording or otherwise without the prior written permission of the publisher. Permissions may be sought directly from Elsevier's Science & Technology Rights Department in Oxford, UK: phone (+ 44) (0) 1865 843830; fax (+44) (0) 1865 853333; email: [permissions@elsevier.com](mailto:permissions@elsevier.com). Alternatively, visit the Science and Technology Books website at [www.elsevierdirect.com/rights](http://www.elsevierdirect.com/rights) for further information

#### Notice

No responsibility is assumed by the publisher for any injury and/or damage to persons or property as a matter of products liability, negligence or otherwise, or from any use or operation of any methods, products, instructions or ideas contained in the material herein. Because of rapid advances in the medical sciences, in particular, independent verification of diagnoses and drug dosages should be made

#### **British Library Cataloguing-in-Publication Data**

A catalogue record for this book is available from the British Library

#### **Library of Congress Cataloging-in-Publication Data**

A catalog record for this book is available from the Library of Congress

ISBN : 978-0-12-381351-0

For information on all Academic Press publications  
visit our website at [elsevierdirect.com](http://elsevierdirect.com)

Typeset by Thomson

Printed and bound in China  
10 11 12 13 14 15 10 9 8 7 6 5 4 3 2 1

# TABLE OF CONTENTS

---

*Preface*    *xiii*

<b>1 Overview</b>	<b>1</b>
I. Scope of Insect Ecology	3
II. Ecosystem Ecology	5
A. Ecosystem Complexity	6
B. The Hierarchy of Subsystems	7
C. Regulation	9
III. Environmental Change and Disturbance	10
IV. Ecosystem Approach To Insect Ecology	12
V. Scope of This Book	12

## SECTION I

### ECOLOGY OF INDIVIDUAL INSECTS

<b>2 Responses to Abiotic Conditions</b>	<b>17</b>
I. The Physical Template	18
A. Biomes	18
B. Environmental Variation	23
C. Disturbances	25

II. Surviving Variable Abiotic Conditions	30
A. Thermoregulation	32
B. Water Balance	35
C. Air and Water Chemistry	38
D. Other Abiotic Factors	39
III. Factors Affecting Dispersal Behavior	41
A. Life History Strategy	41
B. Crowding	41
C. Nutritional Status	42
D. Habitat and Resource Conditions	42
E. Mechanism of Dispersal	43
IV. Responses to Anthropogenic Changes	45
V. Summary	50
<b>3 Resource Acquisition</b>	<b>53</b>
I. Resource Quality	54
A. Resource Requirements	55
B. Variation in Food Quality	55
C. Plant Chemical Defenses	58
D. Arthropod Defenses	66
E. Variation in Resource Quality	70
F. Mechanisms for Exploiting Variable Resource Quality	75
II. Resource Acceptability	79
III. Resource Availability	82
A. Discovering Suitable Resources	83
B. Orientation	84
C. Learning	89
IV. Summary	93
<b>4 Resource Allocation</b>	<b>95</b>
I. Resource Budget	96
II. Allocation of Assimilated Resources	98
A. Foraging and Dispersal Behavior	98
B. Mating Behavior	102
C. Reproductive and Social Behavior	107
D. Competitive, Defensive and Mutualistic Behavior	111
III. Efficiency of Resource Use	118
A. Factors Affecting Efficiency	119
B. Trade-offs	121
IV. Summary	124

## SECTION II

## POPULATION ECOLOGY

<b>5 Population Systems</b>	<b>129</b>
I. Population Structure	130
A. Density	130
B. Dispersion	131
C. Metapopulation Structure	133
D. Age Structure	135
E. Sex Ratio	135
F. Genetic Composition	136
G. Social Insects	139
II. Population Processes	141
A. Natality	142
B. Mortality	142
C. Dispersal	143
III. Life History Characteristics	148
IV. Parameter Estimation	150
V. Summary	155
<b>6 Population Dynamics</b>	<b>157</b>
I. Population Fluctuation	158
II. Factors Affecting Population Size	163
A. Density Independent Factors	163
B. Density Dependent Factors	170
C. Regulatory Mechanisms	170
III. Models of Population Change	174
A. Exponential and Geometric Models	175
B. Logistic Model	176
C. Complex Models	176
D. Computerized Models	178
E. Model Evaluation	179
IV. Summary	182
<b>7 Biogeography</b>	<b>185</b>
I. Geographic Distribution	187
A. Global Patterns	187
B. Regional Patterns	188
C. Island Biogeography	189



D. Landscape and Stream Continuum Patterns	190
II. Spatial Dynamics of Populations	193
A. Expanding Populations	194
B. Metapopulation Dynamics	200
III. Habitat Connectivity	203
IV. Anthropogenic Effects On Spatial Dynamics	204
A. Fragmentation	205
B. Disturbances to Aquatic Ecosystems	208
C. Anthropogenic Transport Across Barriers	209
V. Models of Spatial Dynamics	211
VI. Summary	214

### SECTION III

## COMMUNITY ECOLOGY

<b>8 Species Interactions</b>	<b>219</b>
I. Classes of Interactions	220
A. Competition	221
B. Predation	226
C. Symbiosis	231
II. Factors Affecting Interactions	242
A. Abiotic Conditions	243
B. Resource Availability and Distribution	244
C. Indirect Effects of Other Species	245
III. Consequences of Interactions	253
A. Population Regulation	254
B. Community Regulation	254
IV. Summary	255
<b>9 Community Structure</b>	<b>257</b>
I. Approaches to Describing Communities	258
A. Species Diversity	259
B. Species Interactions	267
C. Functional Organization	273
II. Patterns of Community Structure	275
A. Global Patterns	275
B. Biome and Landscape Patterns	278
III. Determinants of Community Structure	282
A. Habitat Area and Complexity	282
B. Habitat Stability	283
C. Habitat or Resource Conditions	284
D. Species Interactions	285
IV. Summary	287

<b>10 Community Dynamics</b>	<b>293</b>
I. Short-term Change in Community Structure	294
II. Successional Change in Community Structure	297
A. Patterns of Succession	299
B. Factors Affecting Succession	304
C. Models of Succession	308
III. Paleoecology	310
IV. Diversity vs. Stability	316
A. Components of Stability	319
B. Stability of Community Variables	320
V. Summary	321

## SECTION IV

## ECOSYSTEM LEVEL

<b>11 Ecosystem Structure and Function</b>	<b>327</b>
I. Ecosystem Structure	329
A. Physical Structure	330
B. Trophic Structure	331
C. Spatial Variability	332
II. Energy Flow	333
A. Primary Productivity	334
B. Secondary Productivity	337
C. Energy Budgets	338
III. Biogeochemical Cycling	339
A. Abiotic and Biotic Pools	340
B. Major Cycles	341
C. Factors Influencing Cycling Processes	347
IV. Climate Modification	348
V. Ecosystem Modeling	353
VI. Summary	357

<b>12 Herbivory</b>	<b>359</b>
I. Types and Patterns of Herbivory	361
A. Herbivore Functional Groups	361
B. Measurement of Herbivory	361
C. Spatial and Temporal Patterns of Herbivory	365
II. Effects of Herbivory	372
A. Plant Productivity, Survival and Growth Form	372
B. Community Dynamics	379
C. Water and Nutrient Fluxes	385
D. Effects on Climate and Disturbance Regime	392
III. Summary	395

<b>13</b>	<b>Pollination, Seed Predation and Seed Dispersal</b>	<b>397</b>
I.	Types and Patterns of Pollination	399
A.	Pollinator Functional Groups	399
B.	Measurement of Pollination	402
C.	Spatial and Temporal Patterns of Pollination	403
II.	Effects of Pollination	405
III.	Types and Patterns of Seed Predation and Dispersal	410
A.	Seed Predator and Disperser Functional Groups	410
B.	Measurement of Seed Predation and Dispersal	411
C.	Spatial and Temporal Patterns of Seed Predation and Dispersal	416
IV.	Effects of Seed Predation and Dispersal	417
V.	Summary	420
<b>14</b>	<b>Decomposition and Pedogenesis</b>	<b>421</b>
I.	Types and Patterns of Detritivory and Burrowing	423
A.	Detritivore and Burrower Functional Groups	423
B.	Measurement of Detritivory, Burrowing and Decomposition Rates	425
C.	Spatial and Temporal Patterns in Processing of Detritus and Soil	428
II.	Effects of Detritivory and Burrowing	432
A.	Decomposition and Mineralization	432
B.	Soil Structure, Fertility and Infiltration	440
C.	Primary Production and Vegetation Dynamics	446
III.	Summary	451
<b>15</b>	<b>Insects as Regulators of Ecosystem Processes</b>	<b>453</b>
I.	Development of the Concept	454
II.	Ecosystems as Cybernetic Systems	459
A.	Properties of Cybernetic Systems	460
B.	Ecosystem Homeostasis	461
C.	Definition of Stability	463
D.	Regulation of NPP by Biodiversity	465
E.	Regulation of NPP by Insects	471
III.	Summary	476
<b>SECTION V</b>		
<b>APPLICATIONS AND SYNTHESIS</b>		
<b>16</b>	<b>Applications</b>	<b>481</b>
I.	Ecosystem Services	483
A.	Provisioning Services	483
B.	Cultural Services	485

C. Supporting Services	488
D. Regulating Services	488
E. Valuation of Ecosystem Services	490
II. Integrated Pest Management	491
A. Development of the IPM Concept	491
B. Ecological Tactics for Managing Crop and Forest “Pests”	493
C. Ecological Tactics for Managing Medical and Veterinary “Pests”	499
D. Ecological Tactics for Managing Urban “Pests”	501
III. Conservation/Restoration Ecology	504
IV. Invasive Species	508
V. Indicators of Environmental Conditions	510
VI. Summary	511
<b>17 Summary and Synthesis</b>	<b>513</b>
I. Summary	514
II. Synthesis	516
III. Critical Issues	517
IV. Conclusions	522
Bibliography	525
Author Index	607
Taxonomic Index	619
Subject Index	625

This page intentionally left blank

# PREFACE

---

**T**he concept for this book grew during the late 1990s from efforts to educate my insect ecology students on the broad perspective of insect ecology that derives from a synthesis of evolutionary and ecosystem approaches. The traditional evolutionary approach has demonstrated the importance of insect adaptations to environmental conditions for individual fitness, population dynamics and community interactions, whereas the more recent ecosystem approach has shown how insects modify their environment through their effects on primary production, vegetation dynamics, soil development and biogeochemistry, as these regulate global carbon fluxes and climate. Insect evolution represents feedback from ways in which insect phenotypes affect their environment, in the same way that plant adaptations can be seen as feedback from their effects on soil development, carbon and nutrient fluxes and climate.

This third edition provides an updated and expanded synthesis of the feedbacks and interactions between insects and their environment, and adds a new chapter on applications, based on reader feedback. Some of the most exciting recent advances are 1) the identification of gene expression that controls biochemical interactions among insects and other organisms, 2) the identification of specific genes that have been selected by feedback between insect phenotype and environmental conditions, and 3) broadened scope of insect effects on, and responses to, environmental changes. The new Chapter 16 describes the application of insect ecology to various social and environmental issues, including ecosystem services (such as pollination, food and fiber supply, water yield and quality, primary production and soil formation) and pest management.

Ecology, especially ecosystem ecology, necessarily requires a multidisciplinary approach, that involves not only biological disciplines, including molecular biology, but also chemists, geologists, climatologists, hydrologists, soil scientists, geographers, and mathematicians, in order to fully understand and manage the complexity of interactions among organisms and their environment. Despite their small size, insects have demonstrated a

capacity to regulate ecosystem processes that control local-to-global environment. Furthermore, much of what we know about insect ecology has been contributed by studies with an applied orientation, e.g., investigation of factors affecting population dynamics (including insect–plant and predator–prey interactions) to provide tools for managing insect populations.

This text provides the data base for predicting and managing insect effects on ecosystem services, including global carbon fluxes and climate. As we become increasingly aware that global changes must be addressed from a global (rather than local) perspective, we need models with greater integration of ecological processes at various levels of resolution and across regional landscapes. Insect population structure, insect interactions with other species and their effects on ecosystem processes are integral to explaining and mitigating global changes. Furthermore, the increasing recognition that insects have various short and long-term effects on multiple ecosystem services requires a shift in approach, from traditional crop “protection” to integration of compensatory benefits for sustained yield of ecosystem services. Integrated pest management (IPM) is founded on such ecological principles.

A hierarchical model is used in this text to highlight the interactions and feedbacks among individual, population, community, and ecosystem components. This model also contributes to the integration of evolutionary and ecosystem approaches, by illustrating how conditions at higher levels of resolution (e.g., the community or ecosystem) contribute to the environment perceived at lower levels (e.g., populations and individuals), and how responses at lower levels contribute to conditions at higher levels of this hierarchy. Some overlap among sections and chapters is necessary to emphasize linkages among levels. Where possible, overlap is minimized through cross-referencing.

An alternative model would be organization by major topics of current concern, such as evolution, biodiversity, omnivory, biological control, and climate change. However, this topical organization has limited potential for integration and emphasis of the fundamental feedbacks that control many of these processes.

A useful textbook must balance coverage with brevity. A guiding principle for this book has been its emphasis on insect responses to, and effects on, ecosystem structure and function. Evolution is emphasized in the earlier chapters that deal with individual and population responses to environmental conditions, with cross-referencing to later chapters that show how insects affect the ecosystem conditions to which they also respond.

A number of colleagues have contributed enormously to my perspectives on insect and ecosystem ecology. I am especially grateful to J.T. Callahan, J.-T. Chao, S.L. Collins, R.N. Coulson, D.A. Crossley, Jr., R. Dame, D.A. Distler, L.R. Fox, J.F. Franklin, F.B. Golley, J.R. Gosz, V.P. Gutschick, S.M. Heuberger, M.D. Hunter, F. Kozár, G.L. Lovett, M.D. Lowman, H.-K. Luh, J.C. Moore, E.P. Odum, H.T. Odum, T. E. Reagan, T.R. Seastedt, D.J. Shure, M. Stout, P. Turchin, R.B. Waide, W.G. Whitford, R.G. Wiegert, M.R. Willig and W.-J. Wu for sharing ideas, data, and encouragement. A. Covich, L.R. Fox, T.R. Seastedt, D. Simberloff, T. Tscharntke, and M.R. Willig reviewed drafts of previous editions. I also have benefited from collaboration with colleagues at Louisiana State University and Oregon State University and associated with U.S. Long Term Ecological Research (LTER) sites, International LTER projects in Hungary and Taiwan, the Smithsonian Tropical Research Institute, Wind River Canopy Crane Research Facility, Teakettle Experimental Forest, USDA Forest Service Demonstration of Ecosystem Management Options (DEMO)

Project, USDA Western Regional Project on Bark Beetle–Pathogen Interactions, and the National Science Foundation. Several anonymous reviewers provided useful comments. I also am indebted to C. Schwalter for encouragement and feedback. K. Gomez, P. Gonzalez and C. Johnson at Elsevier provided valuable editorial assistance. I am, of course, solely responsible for the selection and organization of material in this book.



This page intentionally left blank

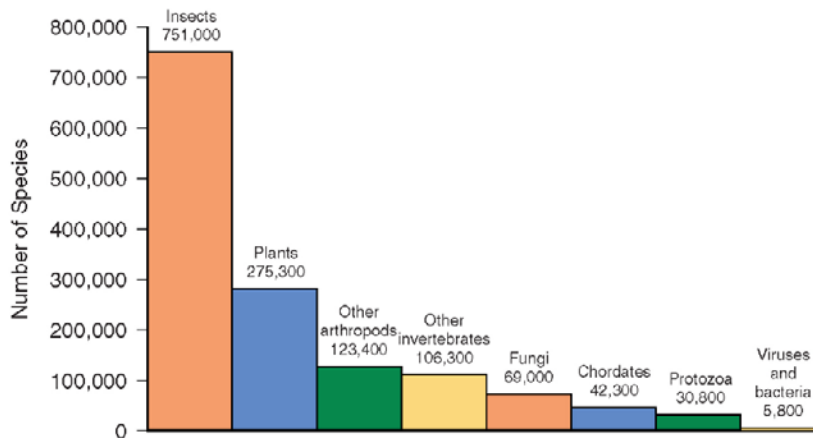
# Overview

- I. Scope of Insect Ecology**
- II. Ecosystem Ecology**
  - A. Ecosystem Complexity*
  - B. The Hierarchy of Subsystems*
  - C. Regulation*
- III. Environmental Change and Disturbance**
- IV. Ecosystem Approach to Insect Ecology**
- V. Scope of This Book**

INSECTS ARE THE DOMINANT GROUP OF ORGANISMS ON EARTH, IN terms of both taxonomic diversity (>50% of all described species) and ecological function (E. Wilson 1992) (Fig. 1.1). Insects represent the vast majority of species in terrestrial and freshwater ecosystems, and are important components of near-shore marine ecosystems, as well. This diversity of insect species represents an equivalent variety of adaptations to variable environmental conditions. Insects affect other species (including humans) and ecosystem parameters in a variety of ways. The capacity for rapid response to environmental change makes insects useful indicators of change, major engineers and potential regulators of ecosystem conditions, and frequent competitors with human demands for ecosystem resources or vectors of human and animal diseases.

Insects play critical roles in ecosystem function. They represent important food resources, predators, parasites or disease vectors for many other organisms, including humans, and they have the capacity to alter rates and directions of energy and matter fluxes (e.g., as herbivores, pollinators, detritivores, and predators) in ways that potentially affect global processes. In some ecosystems, insects and other arthropods represent the dominant pathways of energy and matter flow, and their biomass may exceed that of the more conspicuous vertebrates (e.g., Whitford 1986). Some species are capable of removing virtually all vegetation from a site. They affect, and are affected by, environmental issues as diverse as ecosystem health, biodiversity conservation, food production, genetically modified crops, disease epidemiology, frequency and severity of fire and other disturbances, control of invasive exotic species, land use, water and air pollution and climate change. The rapid change in frequencies of particular genes within insect populations, in response to changing environmental conditions, has provided some of the best confirmation of evolutionary principles.

Adaptation and explosive population growth in response to environmental changes, especially those resulting from anthropogenic activities, have the capacity to exacerbate



**FIG. 1.1** Distribution of described species within major taxonomic groups. Species numbers for insects, bacteria and fungi likely will increase greatly as these groups become better known. Data from E. Wilson (1992).

or mitigate changes in ecosystem conditions and, perhaps, global processes. On the other hand, efforts to control insects have often had unintended and/or undesirable consequences for environmental quality and ecosystem services. Clearly, understanding insect ecology is critical for the effective management of environmental integrity and ecosystem services.

A primary challenge for insect ecologists is to place insect ecology in an ecosystem context, which represents insect effects on ecosystem structure and function, as well as the diversity of their adaptations and responses to changes in environmental conditions. Until relatively recently, insect ecologists have focused on the evolutionary significance of life history strategies and interactions with other species, especially as pollinators, herbivores and predators (Price 1997). This focus has yielded much valuable information about the ecology of individual species and species associations, demonstrated the function of particular genes, and provided the basis for pest management or recovery of threatened and endangered species. However, relatively little attention has been given to the important role of insects as ecosystem engineers, other than to their apparently negative effects on vegetation (especially commercial crop) or animal (especially human and livestock) dynamics.

Ecosystem ecology has advanced rapidly during the past 50 years. Major strides have been made in understanding how species interactions and environmental conditions affect rates of energy and nutrient fluxes in different ecosystem types, how these provide free ecosystem services (such as production of food and pharmaceutical compounds, pollination and air and water filtration), and how environmental conditions both affect and reflect community structure (e.g., Costanza et al. 1997, Daily 1997, H. Odum 1996). Interpreting the responses of a diverse community to multiple, interacting environmental factors in integrated ecosystems requires new approaches, such as multivariate statistical analysis and modeling techniques (e.g., Gutierrez 1996, Liebhold et al. 1993, Marcot et al. 2001). Such approaches often involve loss of detail, such as combination of species into phylogenetic or functional groupings. However, an ecosystem approach provides a framework for integrating insect ecology with changes in ecosystem structure and function, and for applying insect ecology to the understanding of ecosystem, landscape and global issues, such as climate change or sustainability of ecosystem services. Unfortunately, few

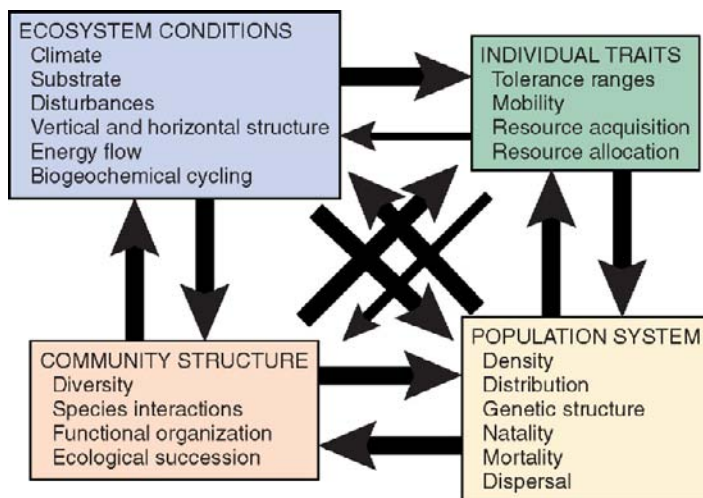
ecosystem studies have involved insect ecologists and, therefore, have tended to under-represent insect responses and contributions to ecosystem changes.

## I. SCOPE OF INSECT ECOLOGY

Insect ecology is the study of interactions between insects and their environment. Ecology is necessarily a multidisciplinary and integrative field of study, requiring the contributions of biologists, chemists, geologists, climatologists, hydrologists, soil scientists, geographers, mathematicians, and others, to fully understand the complex interactions among organisms and their environment (Fig. 1.2). Some of the most exciting recent advances in insect ecology have 1) demonstrated molecular mechanisms that control biochemical interactions among organisms and the selection of genomes best adapted to prevailing conditions and 2) clarified feedback mechanisms that control insect effects on (as well as responses to) environmental changes. Despite their small size, insects have demonstrated a remarkable capacity to regulate ecosystem processes that control local-to-global environmental conditions.

Insect ecology has both basic and applied goals. The basic goals are to improve our understanding and ability to model interactions and feedbacks, in order to predict changes in ecosystem and global conditions (e.g., Price 1997). The applied goals are to evaluate and manage the extent to which insect responses to environmental changes, including those resulting from anthropogenic activities, mitigate or exacerbate ecosystem change (e.g., Croft and Gutierrez 1991, Kogan 1998), especially in managed ecosystems. Some of the earliest and most valuable data on insect ecology has been contributed from studies designed to address factors affecting the population growth of “pests” (e.g., C. Riley 1878, 1880, 1883, 1885, 1893)

Research on insects and associated arthropods (e.g., spiders, mites, centipedes, millipedes, crustaceans) has been critical to development of the fundamental principles of ecology, such as evolution of social organization (Haldane 1932, W. Hamilton 1964,



**FIG. 1.2** Diagrammatic representation of feedbacks between various levels of ecological organization. Sizes of arrows are proportional to strength of interaction. Note that individual traits have a declining direct effect on higher organizational levels, but are affected strongly by feedback from all higher levels.

E. Wilson 1973), population dynamics (Coulson 1979, Morris 1969, Nicholson 1958, Varley and Gradwell 1970, Varley et al. 1973, Wellington et al. 1975), competition (Park 1948, 1954), plant–herbivore (I. Baldwin and Schultz 1983, Feeny 1969, Fraenkel 1953, Rosenthal and Janzen 1979) and predator–prey interaction (Nicholson and Bailey 1935), mutualism (Batra 1966, Bronstein 1998, Janzen 1966, Morgan 1968, Rickson 1971, 1977), island biogeography (Darlington 1943, MacArthur and Wilson 1967, Simberloff 1969, 1978), metapopulation ecology (Hanski 1989) and regulation of ecosystem processes, such as primary productivity, nutrient cycling and succession (Mattson and Addy 1975, J.C. Moore et al. 1988, Schowalter 1981, Seastedt 1984, Smalley 1960). Insects and other arthropods are small and easily manipulated subjects. Their rapid numerical responses to environmental changes facilitate statistical discrimination of responses and make them particularly useful models for experimental study.

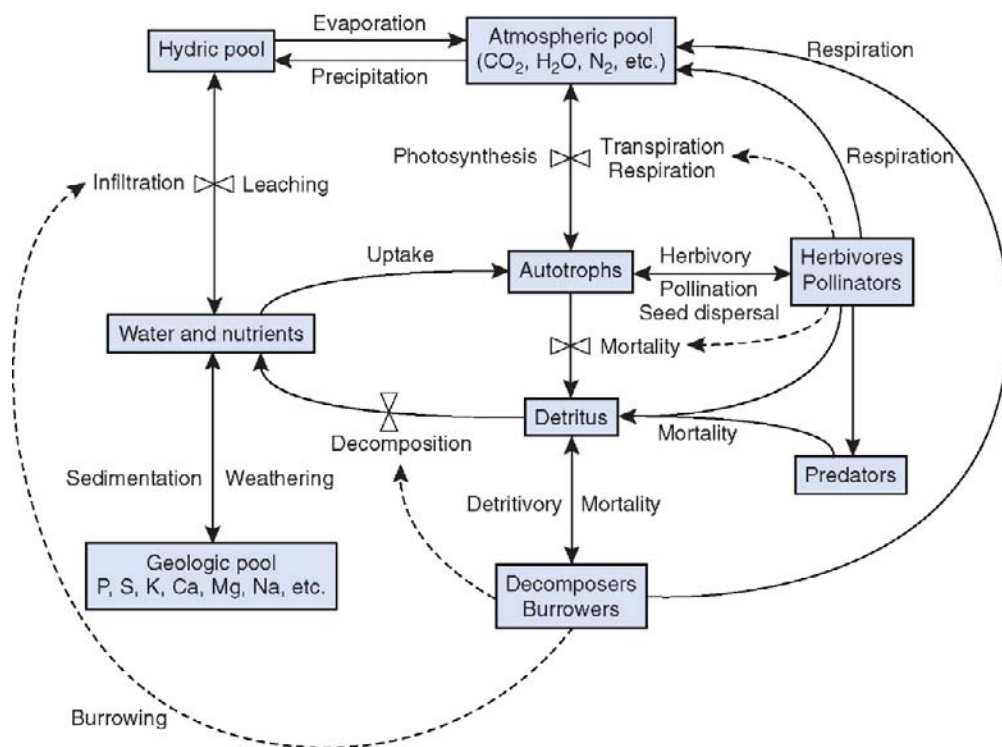
Insects fill a variety of important ecological (functional) roles and affect virtually all ecosystem services. Many species are key pollinators. Pollinators and plants have adapted a variety of mechanisms for ensuring transfer of pollen, especially in tropical ecosystems where sparse distributions of many plant species require a high degree of pollinator fidelity to ensure successful pollination among conspecific plants (Feinsinger 1983). Other species are important agents for the dispersal of plant seeds, fungal spores, bacteria, viruses, or other invertebrates (J. Moser 1985, Nault and Ammar 1989, Sallabanks and Courtney 1992). Herbivorous species are particularly well-known as agricultural and forestry “pests”, but their ecological roles are far more complex, often stimulating plant growth, affecting water and nutrient fluxes, and altering the rate and direction of ecological succession (MacMahon 1981, Maschinski and Whitham 1989, Mattson and Addy 1975, Schowalter and Lowman 1999, Schowalter et al. 1986, Trumble et al. 1993). Insects and associated arthropods are instrumental in processing of organic detritus in terrestrial and aquatic ecosystems, and influence soil fertility and water quality (Coleman et al. 2004, Kitchell et al. 1979, Seastedt and Crossley 1984). Woody litter decomposition typically is delayed until insects penetrate the bark barrier and inoculate the wood with saprophytic fungi and other microorganisms (Ausmus 1977, Dowding 1984, Swift 1977). Insects are important food resources for a variety of fish, amphibians, reptiles, birds and mammals, as well as other invertebrate predators and parasites (J. Allan et al. 2003, Baxter et al. 2005). Humans have used insects or their products for food, and for medical and industrial products (e.g., Anelli and Prischman-Voldseth 2009, Namba et al. 1988, Ramos-Elorduy 2009). In addition, some insects are important vectors of plant and animal diseases, including examples such as malaria and plague, that affect human and wildlife population dynamics (Amoo et al. 1993, Diamond 1999, Edman 2000, Marra et al. 2004, R. Peterson 1995, Stapp et al. 2004, Steelman 1976, J. Zhou et al. 2002).

The significant economic and public health importance of many insect species is the justification for distinct entomology programs in land-grant universities and government agencies. Damage to agricultural crops and transmission of human and livestock diseases has stimulated interest in, and support for, study of factors influencing abundance and effects of these insect species. Much of this research has focused on evolution of life history strategies, orientation to host cues, interaction with host chemistry, and predator–prey interactions, since these contribute to our understanding of “pest” population dynamics, especially population regulation by biotic and abiotic factors. However, failure to understand these aspects of insect ecology within an ecosystem context undermines our ability to predict and manage insect populations and ecosystem resources effectively, especially with respect to changes in land use and sustainability of ecosystem services such as

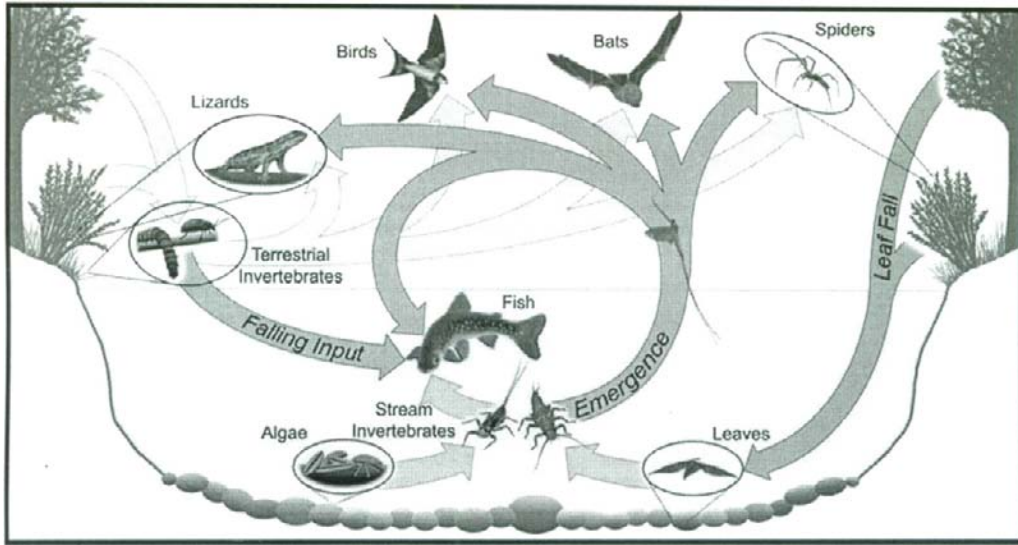
pollination, water yield and soil fertility (Kogan 1998, Millenium Ecosystem Assessment 2005). Suppression efforts may be counterproductive to the extent that insect outbreaks represent ecosystem-level regulation of critical processes in some ecosystems.

## II. ECOSYSTEM ECOLOGY

The ecosystem is a fundamental unit of ecological organization, although its boundaries are not easily defined. An ecosystem generally is considered to represent the integration of a more or less discrete community of organisms and the abiotic conditions at a site (Fig. 1.3). However, research and environmental policy decisions are recognizing the importance of scale in ecosystem studies, i.e., extending research or extrapolating results to landscape, regional, and even global, scales (e.g., Holling 1992, M. Turner 1989). Ecosystems are interconnected, just as the species within them are interconnected. Exports from one ecosystem become imports for others (Fig. 1.4). Energy, water, organic matter and nutrients from terrestrial ecosystems are major sources of these resources for many aquatic ecosystems. Organic matter and nutrients eroded by wind from arid ecosystems are filtered from the airstream by ecosystems downwind. Some ecosystems within a landscape or watershed are the sources of colonists for other, recently disturbed ecosystems. Insect outbreaks can spread from one ecosystem to another. Toxic or exogenous materials introduced into some ecosystems can adversely affect other ecosystems



**FIG. 1.3** Conceptual model of ecosystem structure and function. Boxes represent storage compartments, lines represent fluxes, and hourglasses represent regulation. Solid lines are direct transfers of energy and matter, and dashed lines are informational or regulatory pathways.



**FIG. 1.4** Diagram of exchange of aquatic and terrestrial invertebrate prey and plant material that have direct and indirect effects in stream and riparian ecosystem food webs. From Baxter et al. (2005) with permission from John Wiley & Sons.

remote from the source, e.g., agricultural chemicals causing hypoxic (dead) zones in coastal waters (Krug 2007). Therefore, our perspective of the ecosystem needs to incorporate the concept of interactions among ecosystem types (patches) within the landscape or watershed.

Overlapping gradients in abiotic conditions establish the template that limits options for community development, but established communities can modify abiotic conditions to varying degrees. For example, minimum rates of water and nutrient supply are necessary for establishment of grasslands or forests, but once canopy cover, and water and nutrient storage capacity in organic material have developed, the ecosystem is relatively buffered against changes in water and nutrient supply (e.g., J. Foley et al. 2003a, E. Odum 1969, Webster et al. 1975). Although ecosystems typically are defined on the basis of the dominant vegetation (e.g., tundra, desert, marsh, grassland, forest) or type of water body (stream, pond, lake), characteristic insect assemblages also differ among ecosystems. For example, wood-boring insects (e.g., ambrosia beetles, wood wasps) are characteristic of communities in wooded ecosystems (shrub and forest ecosystems), but clearly could not survive in ecosystems lacking woody resources. The perspective of ecosystems represented in this text emphasizes complexity, hierarchical organization, and regulation of structure and function.

## A. Ecosystem Complexity

Ecosystems are complex systems having **structure**, represented by abiotic resources and a diverse assemblage of component species and their products (such as organic detritus and tunnels) and **function**, represented by fluxes of energy and matter among biotic and abiotic components (Fig. 1.3). Heterogeneous distribution of environmental conditions, resources and organisms is a fundamental ecological property (Scheiner and Willig 2008) that controls individual foraging and dispersal strategies, patterns of population

density and interactions with other species populations, and resulting patterns of energy and biogeochemical fluxes. Ecosystems can be identified at micro- and meso-scales (e.g., decomposing logs or treehole pools), patch scale (area encompassing a particular community type on the landscape), landscape scale (the mosaic of patch types representing different edaphic conditions or successional stages that compose a broader ecosystem type), the regional or biome scale, and the continental scale. Furthermore, ecosystems tend to change over time as populations appear or disappear, changing community and ecosystem structure and function.

Addressing taxonomic, temporal and spatial complexity has proven a daunting challenge to ecologists, who must decide how much complexity can be ignored safely (Gutierrez 1996, Polis 1991a, b). Evolutionary and ecosystem ecologists have taken contrasting approaches to dealing with complexity in ecological studies. The evolutionary approach emphasizes adaptive aspects of life histories, population dynamics and species interactions. This approach restricts complexity to interactions among one, or a few, species and their hosts, competitors, predators or other biotic and abiotic environmental factors, and often ignores the complex, direct and indirect feedbacks at the ecosystem level. On the other hand, the ecosystem approach emphasizes rates and directions of energy and matter fluxes. This approach restricts complexity to fluxes among functional groups and often ignores the contributions of individual species. Either approach, by itself, limits our ability to understand feedbacks among individual, population, community and ecosystem parameters and to predict effects of a changing global environment on these feedbacks.

## B. The Hierarchy of Subsystems

Complex systems with feedback mechanisms can be partitioned into component subsystems, which are themselves composed of sub-subsystems. Viewing the ecosystem as a nested hierarchy of subsystems (Table 1.1), each with its particular properties and processes (Coulson and Crossley 1987, Kogan 1998, O' Neill et al. 1986), facilitates understanding of complexity. Each level of the hierarchy can be studied at an appropriate level of detail and its properties explained by the integration of its subsystems. For example, population responses to changing environmental conditions reflect the net physiological and behavioral responses of individuals that determine their survival and reproduction. Changes in community structure reflect the dynamics of component populations. Fluxes of energy and matter through the ecosystem reflect community organization and interaction. Landscape structure reflects ecosystem processes that affect the movement of individuals. Hence, the integration of structure and function at each level determines properties at higher levels.

At the same time, the conditions produced at each level establish the context, or template, for responses at lower levels. Population structure resulting from individual survival, dispersal and reproduction determines future survival, dispersal and reproduction of individuals. Ecosystem conditions resulting from community interactions affect the subsequent behavior of individual organisms, populations, and the community. Recognition of feedbacks from higher levels has led to the developing concepts of inclusive fitness (fitness accruing through feedback from benefit to a group of organisms) and ecosystem self-regulation (see Chapter 15). The hypothesis that insects function as cybernetic regulators that stabilize ecosystem properties (M.D. Hunter 2001b, Mattson and Addy 1975, Schowalter 1981) has been one of the most important and controversial concepts to emerge from insect ecology.



**TABLE 1.1** Ecological hierarchy and the structural and functional properties characterizing each level.

Ecological Level	Structure	Function
Global	Biome distribution Atmospheric condition Climate Sea level	Gas, water, nutrient exchange between terrestrial and marine systems Total NPP
Biome	Landscape pattern Temperature, moisture profile Disturbance regime	Energy and matter fluxes Integrated NPP of ecosystems Migration
Landscape	Disturbance pattern Community distribution Metapopulation structure	Energy and matter fluxes Integrated NPP of ecosystems Colonization and extinction
Ecosystem	Vertical and horizontal structure Disturbance type and frequency Biomass Functional organization	Energy and matter fluxes Succession NPP, herbivory Decomposition, pedogenesis
Community	Diversity Trophic organization	Species interactions Temporal and spatial changes
Population	Density Dispersion Age structure Genetic structure	Natality Mortality Dispersal Gene flow Temporal and spatial changes
Individual	Anatomy Genome	Physiology/learning/behavior Resource acquisition and allocation

Ecosystem processes represent the integration of processes at the level of component communities. Component communities are subsystems, i.e., more or less discrete assemblages of organisms based on particular resources. For example, the relatively distinct soil faunas associated with fungal, bacterial or plant root resources represent different component communities (J.C. Moore and Hunt 1988). Component communities are composed of individual species populations, with varying strategies for acquiring and allocating resources. Species populations, in turn, are composed of individual organisms with variation in individual physiology and behavior. Ecosystems can be integrated at the landscape or biome levels, and biomes integrated at the global (biosphere) level. Spatial and temporal scales vary across this hierarchy. While individual physiology and behavior operate on small scales of space and time (i.e., limited to the home range and life span of the individual), population dynamics span landscape and decadal scales, and ecosystem processes, such as patterns of resource turnover, recovery from disturbance or contributions to atmospheric carbon, operate at spatial scales from the patch to the biome, and over time scales from decades to millennia.

Modeling approaches have greatly facilitated understanding of the complexity and consequences of interactions and linkages within and among these organizational levels of ecosystems. The most significant challenges to ecosystem modelers remain a) the

integration of appropriately detailed submodels at each level, in order to improve prediction of causes and consequences of environmental changes, and b) the evaluation of the contributions of various taxa (including particular insects) or functional groups to ecosystem structure and function. Some species or structures have effects that are disproportionate to their abundance or biomass (i.e., keystone species). Studies focused on the most abundant or conspicuous species or structures fail to address substantial contributions of rare or inconspicuous components, such as many insects.

### C. Regulation

An important aspect of this functional hierarchy is the “emergence” of properties that are not easily predicted by simply adding the contributions of constitutive components. Emergent properties include feedback processes at each level of the hierarchy. For example, individual organisms acquire and allocate energy and biochemical resources, affecting resource availability and population structure in ways that change the environment and determine future options for acquisition and allocation of these same resources. Regulation of density and resource use emerges at the population level through negative feedback, via declining resource availability and increasing predation at larger population sizes, that functions to prevent overexploitation and/or through positive feedback, that prevents extinction. Similarly, species populations acquire and transport resources, but regulation of energy flow and biogeochemical cycling emerge at the ecosystem level. Potential regulation of atmospheric and oceanic pools of carbon and nutrients at the global level reflects integration of biogeochemical cycling and energy fluxes among the Earth’s ecosystems, e.g., sequestration of excess atmospheric carbon from wildfire or fossil fuel combustion in wood (in forests) or calcium carbonate (in reefs).

Information flow and feedback processes are the mechanisms of regulation. Although much research has addressed energy and material flow through food webs, relatively few studies have quantified the importance of indirect interactions or information flow. Indirect interactions and feedbacks are common features of ecosystems. For example, herbivores feeding above-ground alter the availability of resources for root-feeding organisms (Gehring and Whitham 1991, 1995, Masters et al. 1993); early-season herbivory can affect plant suitability for later-season herbivores (Harrison and Karban 1986, M.D. Hunter 1987). Information can be transmitted as volatile compounds that advertise the location and physiological condition of prey, the proximity of potential mates and the population status of predators (Bruinsma and Dicke 2008, Kessler and Baldwin 2001, Turlings et al. 1995). Such information exchange is critical to discovery of suitable hosts, attraction of mates, regulation of population density and defense against predators by many (if not all) insects.

This ecosystem information network among the members of the community, along with resource supply/demand relationships, provides the basis for regulation of ecosystem processes. Levels of herbivory and predation are sensitive to resource availability. If environmental conditions increase resource abundance at any trophic level, communication to, and response by, the next trophic level provides negative feedback that reduces resource abundance. Negative feedback is a primary mechanism for stabilizing population sizes, species interactions, and process rates in ecosystems. Some interactions provide positive feedback, such as cooperation or mutualism. Although positive feedback is potentially destabilizing, it may reduce the probability of population decline to extinction. The apparent ability of many ecosystems to reduce variation in structure and function

suggests that ecosystems are self-regulating, i.e., they behave like cybernetic systems (e.g., E. Odum 1969, B. Patten and Odum 1981). Insects could be viewed as important mechanisms of regulation because their normally small biomass requires relatively little energy or matter to maintain, but their rapid and dramatic population response to environmental changes constitutes an effective and efficient means for reducing deviation in nominal ecosystem structure and function (e.g., reducing plant biomass in excess of long-term water supply). This developing concept of ecosystem self-regulation has major implications for ecosystem responses to anthropogenic change in environmental conditions and for our approaches to managing insects and ecosystem resources.

### III. ENVIRONMENTAL CHANGE AND DISTURBANCE

Environmental changes across temporal and spatial gradients are critical components of an ecosystem approach to insect ecology. Insects are highly responsive to environmental changes, including those resulting from anthropogenic activity. Many insects have considerable capacity for long distance dispersal, enabling them to find and colonize isolated resources as these appear. Other insects are flightless, and hence vulnerable to environmental change or habitat fragmentation. Because of their small size, short life spans, and high reproductive rates, the abundances of many species can change by several orders of magnitude on a seasonal or annual time scale, minimizing time lags between environmental changes and population adjustment to new conditions. Such changes are easily detectable and make insects more useful as indicators of environmental changes than are larger or longer-lived organisms that respond more slowly. In turn, insect responses to environmental change can affect ecosystem structure and function dramatically. Some phytophagous species are well-known for their ability, at high population levels, to reduce host plant density and productivity greatly over large areas. Effects of other species may be more subtle but equally significant from the standpoint of long-term ecosystem structure and function.

Environmental change operates on a continuum of spatial and temporal scales. Although strict definitions of environmental change and disturbance have proven problematic, environmental change generally occurs over a longer term, whereas disturbances are acute, short-term events (Walker and Willig 1999, P. White and Pickett 1985). Chronic changes in temperature or precipitation patterns, such as following the last glaciation, occur on a scale of  $10^3$ – $10^5$  yrs and may be barely detectable on human time scales. Long term changes may be difficult to distinguish from cycles operating over decades or centuries, leading to disagreements over whether measured changes represent a fluctuation or a long-term trend. Acute events, such as fires or storms, are more recognizable as disturbances that have dramatic effects on time scales of seconds to hours. However, the duration at which a severe drought, for example, is considered a climate change, rather than a disturbance, has not been determined. The combination of climate and geological patterns, disturbances and environmental changes creates a constantly shifting landscape mosaic of various habitat and resource patches that determine where and how insects and other organisms find suitable conditions and resources.

Insect outbreaks traditionally have been viewed as disturbances (Walker and Willig 1999, P. White and Pickett 1985). P. White and Pickett (1985) defined “disturbance” as any relatively discrete event in time that causes measurable change in population, community or ecosystem structure or function. This definition clearly incorporates insect outbreaks. Similarly, human activities have become increasingly prominent agents of disturbance and environmental change.

Insect outbreaks are comparable to physical disturbances in terms of severity, frequency and scale. Insects can defoliate or kill most host plants over large areas, up to  $10^3$ – $10^6$  ha (e.g., Furniss and Carolin 1977). For example, 39% of a montane forest landscape in Colorado has been affected by insect outbreaks (spruce beetle, *Dendroctonus rufipennis*) since about 1633, compared to 59% by fire and 9% by snow avalanches (Veblen et al. 1994), with an average return interval of 117 yrs, compared to 202 yrs for fire. Frequent, especially cyclic, outbreaks of herbivorous insects probably have been important in selection for plant defenses.

However, unlike abiotic disturbances, insect outbreaks are biotic responses to a change in environmental conditions. Recent outbreaks most commonly reflect anthropogenic redistribution of resources, especially in the increased density of commercially-valuable (often exotic) plant species, and exotic insect species. Outbreaks typically develop in dense patches of host plants and tend to reduce host density, increase vegetation diversity and increase water and nutrient availability (Schowalter et al. 1986). Management responses to insect outbreaks often are more damaging to ecosystem conditions than is the insect outbreak itself. For example, insecticides, such as arsenicals and chlorinated hydrocarbons, have had long-term, non-selective effects on non-target organisms. Removing dead or dying host plants, and even living plants, in advance of insect colonization, has caused serious soil disturbance and erosion, as well as change in community structure. Principles of integrated pest management (IPM) have improved the approaches to managing insects by emphasizing adherence to ecological principles (see Chapter 16). Consideration of insects as integral components of potentially self-maintaining ecosystems could further improve our management of insects and ecosystem resources, within the context of global change.

Currently, human alteration of Earth's ecosystems is substantial and accelerating (Burney and Flannery 2005, J. Thomas et al. 2004, Vitousek et al. 1997). Anthropogenic changes to the global environment affect insects in various ways. Combustion of fossil fuels has elevated atmospheric concentrations of  $\text{CO}_2$  (Beedlow et al. 2004, Keeling et al. 1995), methane, ozone, nitrous oxides and sulfur dioxide, leading to increasingly acidic precipitation and prospects of global warming. Petrochemical leaks and spills are toxic to most organisms and prevent oxygen exchange between aquatic ecosystems and the atmosphere. Some insect species show high mortality as a direct result of toxins in air or water, whereas other species are affected indirectly by changes in resource conditions induced by atmospheric change (Alstad et al. 1982, Arnone et al. 1995, Couceiro et al. 2007, Heliövaara 1986, Kinney et al. 1997, Lincoln et al. 1993, W. Smith 1981). However, the anthropogenic changes with the most immediate effects are land use patterns and redistribution of exotic species, including plants, insects, and livestock. Conversion of natural ecosystems is altering and isolating natural communities at an unprecedented rate, leading to outbreaks of insect "pests" in crop monocultures and fragmented ecosystems (Roland 1993), and potentially threatening species incapable of surviving in increasingly inhospitable landscapes (Samways et al. 1996, Shure and Phillips 1991, A. Suarez et al. 1998). Invasive species affect the structure and processes of communities and ecosystems, both directly and indirectly (Kizlinski et al. 2002, Orwig 2002, N. Sanders et al. 2003). J. Thomas et al. (2004) compared species losses of British butterflies, birds and plants, and found that loss of butterfly species has been greater than that of birds and plants; current rates of species disappearance represent the sixth major extinction event in the last 450 million years. Predicting and mitigating species losses or pest outbreaks depends strongly on our understanding of insect ecology within the context of ecosystem structure and function.

## IV. ECOSYSTEM APPROACH TO INSECT ECOLOGY

Insect ecology can be approached using a hierarchical model described above (Coulson and Crossley 1987). Ecosystem conditions represent the environment, i.e., the combination of physical conditions, interacting species and availability of resources, that determine survival and reproduction by individual insects, but insect activities, in turn, alter vegetation cover, soil properties, community organization, etc. (Fig. 1.2). A hierarchical approach offers a means of integrating the evolutionary and ecosystem approaches to studying insect ecology. The evolutionary approach focuses at lower levels of resolution (individual, population and community) and emphasizes individual and population adaptation to variable environmental conditions through natural selection. The ecosystem approach focuses at higher levels of resolution (community, ecosystem and landscape) and emphasizes the effects of organisms on environmental conditions. Natural selection can be viewed as feedback from the alteration of ecosystem conditions by co-evolving organisms. The evolutionary and ecosystem perspectives are most complementary at the community level, where species diversity, as emphasized by the evolutionary approach, is the basis for functional organization emphasized by the ecosystem approach.

Although the evolutionary approach has provided valuable explanations for the way in which complex interactions have arisen, current environmental issues require an understanding of how insect functional roles affect ecosystem, landscape and global processes. Insect ecologists have recognized insects as important components of ecosystems, but have only recently begun to explore the key roles that insects play as ecosystem engineers. Insects affect primary productivity and organic matter turnover in ways that greatly alter, and potentially regulate, ecological succession, biogeochemical cycling, carbon and energy fluxes, albedo, and hydrology, perhaps affecting regional and global climate as well. These roles may complement or exacerbate changes associated with human activities. Therefore, the purpose of this book is to address the fundamental issues of insect ecology as they relate to ecosystem, landscape and global processes.

## V. SCOPE OF THIS BOOK

This book is organized hierarchically, to emphasize feedbacks among individual, population and community levels and the ecosystems they represent. Four questions have been used to develop this text:

1. How do insects respond to variation in environmental conditions, especially gradients in abiotic factors and resource availability (Section I)?
2. How do interactions among individuals affect the structure and function of populations and communities (Sections II and III)?
3. How do insect-induced changes in ecosystem properties affect the gradients in environmental conditions to which individuals respond (Section IV)?
4. How can this information be incorporated into management decisions and environmental policy (Section V)?

Chapter and topic organization are intended to address these questions by emphasizing key spatial and temporal patterns and processes at each level and their integration among levels. Environmental policy and management decisions (Section V) depend on evaluation of insect effects on ecosystem parameters and their responses to environmental change. The evaluation of insect effects on ecosystem parameters and their responses to environmental

change (Section IV) depends on an understanding of species diversity, interactions, and community organization (Section III) that, in turn, depends on understanding of population dynamics and biogeography (Section II). This, then, depends on understanding of individual physiological and behavioral responses to environmental variation (Section I).

Three themes integrate these ecological levels. First, spatial and temporal patterns of environmental variability and disturbance determine survival and reproduction of individuals and patterns of population, community and ecosystem structure and dynamics. Individual acquisition and allocation of resources, population distribution and colonization and extinction rates, community patterns and successional processes, and ecosystem structure and function reflect environmental conditions. Second, energy and nutrients move through individuals, populations and communities and abiotic pools. The net foraging success and resource use by individuals determine energy and nutrient fluxes at the population level. Trophic interactions among populations determine energy and nutrient fluxes at the community and ecosystem levels. Third, regulatory mechanisms at each level serve to balance resource demands with resource availability (carrying capacity), or to dampen responses to environmental changes. Regulation results from a balance between the negative feedbacks that reduce population sizes or process rates and the positive feedbacks that increase population sizes or process rates. Regulation of population sizes and process rates tends to stabilize ecosystem conditions within ranges favorable to most members. The capacity to regulate environmental conditions increases from individual to ecosystem levels (Fig. 1.2). If feedbacks within or among levels contribute to ecosystem stability, then human influences on ecosystem structure and function could enhance or seriously impair this function.

Section I (Chapters 2–4) addresses the physiological and behavioral ecology of insects. Physiology and behavior represent the means by which organisms interact with their environment. Physiology represents “fixed” adaptations to predictable variation in environmental conditions, whereas behavior represents a more flexible means of adjusting to unpredictable variation. Chapter 2 summarizes insect responses to variable habitat conditions, especially gradients in climate, soil and chemical conditions. Chapter 3 describes physiological and behavioral mechanisms for acquiring energy and matter resources, and Chapter 4 addresses the allocation of assimilated resources to various metabolic and behavioral pathways. These chapters provide a basis for understanding distribution patterns and movement of energy and matter through populations and communities.

Section II (Chapters 5–7) deals with population ecology. Populations of organisms integrate variation in adaptive strategies and foraging patterns among individuals. Chapter 5 outlines population systems, including population structure and the processes of reproduction, mortality and dispersal. Chapter 6 addresses processes and models of population change. Chapter 7 describes biogeography, processes and models of colonization and extinction, and metapopulation dynamics over landscapes. These population parameters determine population effects on ecological processes through time in various patches across regional landscapes.

Section III (Chapters 8–10) addresses community ecology. Species populations interact with other species in a variety of ways that determine changes in community structure through time and space. Chapter 8 describes species interactions (e.g., competition, predation, symbioses). Chapter 9 addresses measures of diversity and community structure and spatial patterns in community structure. Chapter 10 addresses changes in community structure over varying temporal scales. Changes in community structure determine spatial and temporal patterns of energy and nutrient storage and flux through ecosystems.

Section IV (Chapters 11–15) focuses on ecosystems and is the major contribution of this text to graduate education in insect ecology. Chapter 11 represents a primer for general aspects of ecosystem structure and function, especially processes of energy and matter storage and flux that determine resource availability and environmental conditions. Chapter 12 describes patterns of herbivory and its effects on ecosystem parameters; Chapter 13 describes patterns and effects of pollination, seed predation and seed dispersal, and Chapter 14 describes patterns and effects of detritivory and burrowing on ecosystem processes. Chapter 15 addresses the developing concept of ecosystem self-regulation and mechanisms, including species diversity and insect effects, which may contribute to ecosystem stability.

Section V (Chapters 16–17) represents a synthesis, including applications of insect ecology to environmental issues. Chapter 16 provides examples of applications to pest management, conservation, and sustainability of ecosystem services. Chapter 17 summarizes and synthesizes previous chapters and suggests future directions and data necessary to improve understanding of linkages and feedbacks among hierarchical levels. Solutions to environmental problems require consideration of insect ecology at ecosystem, landscape and global levels. Although the focus of this book clearly is on insects, examples from studies of other organisms are used where appropriate to illustrate concepts.

# ECOLOGY OF INDIVIDUAL INSECTS

THE INDIVIDUAL ORGANISM IS A FUNDAMENTAL UNIT OF ecology. Responses to environmental conditions determine an individual's fitness. Individual use of habitat and food resources alters spatial and temporal patterns of habitat structure and resource distribution for other organisms. Insects have been particularly successful in adapting to environmental changes over 400 million years (Romoser and Stoffolano 1998). Several attributes have contributed to their evolutionary and ecological success.

Small size (an attribute shared with other invertebrates and microorganisms) has permitted exploitation of habitat and food resources at a microscopic scale. Insects find protection from adverse conditions in microsites too small for larger organisms, e.g., within individual leaves. Large numbers of insects can exploit the resources represented by a single leaf, by partitioning them, with some species feeding on cell contents, others on sap in leaf veins, some on top of the leaf, others on the underside, some internally. At the same time, small size makes insects sensitive to changes in temperature, moisture, air or water chemistry and other factors.

The exoskeleton (shared with other arthropods) provides protection against predation, desiccation or water-logging (necessary for small organisms), as well as innumerable points of muscle attachment (for flexibility). However, the exoskeleton also limits the size attainable by arthropods. The increased weight of exoskeleton that would be required to support larger body size would limit mobility. Larger arthropods occurred prehistorically, before the appearance of faster, more flexible vertebrate predators. Larger arthropods also occur in aquatic environments, where water helps support their weight.



---

Metamorphosis is necessary for exoskeleton-limited growth but permits partitioning of habitats and resources among life stages. Immature and adult insects can differ dramatically in form and function and thereby can live in different habitats and feed on different resources, reducing intra-specific competition. For example, dragonflies and mayflies live in aquatic ecosystems as immatures, but in terrestrial ecosystems as adults. Many butterflies and beetles feed on foliage as immatures and on nectar as adults. Among holometabolous insects, the quiescent, pupal stage facilitates survival during unfavorable environmental conditions. However, insects, as well as other arthropods, are particularly vulnerable to desiccation and predation during ecdysis (molting).

Finally, flight evolved first among insects and conferred a distinct advantage over other organisms. Flight permits rapid long-distance movement, and so facilitates discovery of new resources, as well as escape from predators or unfavorable conditions. Flight remains a dominant feature of insect ecology.

This section of the book focuses on aspects of physiology and behavior that affect insect interactions with environmental conditions, specifically those adaptations that favor survival and reproduction in variable environments, and mechanisms for finding, exploiting and allocating resources. Physiology and behavior are closely integrated. For example, movement, including dispersal, is affected by physiological perception of temperature and chemical gradients, fat storage, rapid oxygen supply, etc. Similarly, physiological processes are affected by insect selection of thermally suitable location, choice of food resources, etc. Chemical defenses against predators are based on physiological processes, but often are enhanced by behaviors that increase their effect, e.g., thrashing or regurgitation. Organisms affect ecosystem processes, such as energy and nutrient fluxes, through the spatial and temporal patterns of energy and nutrient acquisition and allocation.

Chapter 2 deals with physiological and behavioral responses to changing environmental conditions. Chapter 3 addresses physiological and behavioral mechanisms for finding and exploiting resources. Chapter 4 describes allocation of resources to various metabolic pathways and behaviors that facilitate resource acquisition, mate selection, reproduction, interaction with other organisms, etc. Physiology and behavior interact to determine the conditions under which insects can survive and the means by which they acquire and use available resources. These ecological attributes affect population ecology (such as population structure, changes in population size, biogeography, etc., Section II), community attributes (such as use of, or use by, other organisms as resources, Section III), and ecosystem attributes (such as rates and directions of energy and matter flows, Section IV).

# Responses to Abiotic Conditions

## I. The Physical Template

- A. Biomes
- B. Environmental Variation
- C. Disturbances

## II. Surviving Variable Abiotic Conditions

- A. Thermoregulation
- B. Water Balance
- C. Air and Water Chemistry
- D. Other Abiotic Factors

## III. Factors Affecting Dispersal Behavior

- A. Life History Strategy
- B. Crowding
- C. Nutritional Status
- D. Habitat and Resource Conditions
- E. Mechanism of Dispersal

## IV. Responses to Anthropogenic Changes

## V. Summary

### Disease vector response to anthropogenic disturbance

Human alteration of environmental conditions affects insect populations, in some cases bringing insects and humans into greater conflict. Póvoa et al. (2003) suggested that the reappearance of *Anopheles darlingi* and malaria in Belém, Brazil in 1992, after its presumed elimination in 1968, resulted from human encroachment into deforested areas that had become more favorable mosquito habitat. Vittor et al. (2006) tested this hypothesis in northeastern Peru, where malaria also had dropped dramatically during the 1960s as a result of eradication efforts and remained below 2 cases per 1000 population until the 1990s. Construction of the Iquitos-Nauta road into the region during the 1980s and 1990s initiated deforestation, and allowed rapid settlement and small-scale subsistence agriculture. A sudden increase in the incidence of malaria was observed during the 1990s, reaching more than 120,000 cases (340 per 1000 population) in 1997. During 2000 Vittor et al. (2006) selected replicate sites along the Iquitos-Nauta road to represent high, medium or low percentages of deforestation (based on satellite imagery) and human population density (within a 500m radius around the sample site). Rates of mosquito landing on research personnel were measured at each site between 1800 and 2400 hr (the period of peak mosquito

activity) and compared among the different land uses and demography treatments. Because mosquito reproduction occurred primarily in ponds and fish farms associated with cleared or naturally open areas, and adult mosquitoes did not fly far from breeding sites, biting rates reflected local populations of mosquitoes. Sites with <20% forest and >30% grass/crop cover had a 278-fold higher biting rate than did sites with >70% forest and <10% grass/crop cover. Based on mean percentages of infective *A. darlingi* in the Amazon region (0.5–2.1% infective mosquitoes), Vittor et al. (2006) calculated 38 infective bites  $\text{yr}^{-1} \text{km}^{-2}$  in areas with >35% grass/crop cover and 8–11 infective bites  $\text{yr}^{-1} \text{km}^{-2}$  in areas with 2–35% grass/crop cover, compared to 0.1 infective bites  $\text{yr}^{-1} \text{km}^{-2}$  in areas with <2% grass/crop cover, presenting serious challenges for disease control as deforestation progresses and human population increases. Human contact with novel zoonotic diseases is likely to increase as intrusion into previously unpopulated areas increases (K.F. Smith et al. 2007).

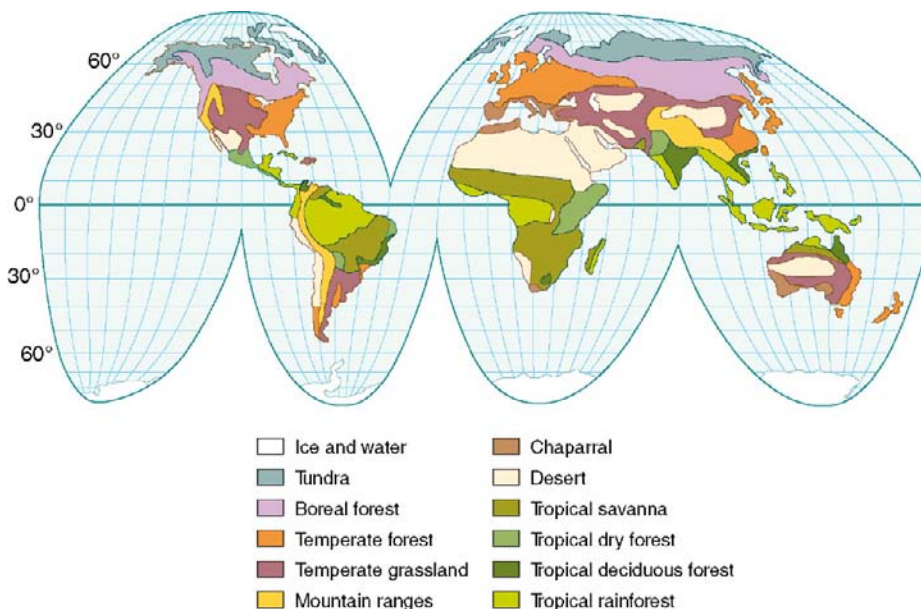
## INTRODUCTION

INSECTS ARE A DOMINANT GROUP OF ORGANISMS FOUND IN VIRTUALLY all terrestrial, freshwater and near-coastal marine habitats, including many of the harshest ecosystems on the globe (e.g., deserts, hot springs and tundra), but individual species have more restricted ranges of occurrence. One of the earliest (and still important) objectives of ecologists was explanation of the spatial and temporal patterns of species distributions (e.g., Andrewartha and Birch 1954, Shelford 1918, A. Wallace 1876). The geographical ranges of insect species generally are determined by their tolerances, or the tolerances of their food resources and predators, to variation in abiotic conditions. Tolerance ranges are under genetic control (W. Bradshaw and Holzapfel 2001). Insect morphological, physiological and behavioral adaptations reflect the characteristic physical conditions of the habitats in which they occur. However, variation in physical conditions requires some flexibility in physiological and behavioral traits. All ecosystems experience climatic fluctuation and periodic disturbances that affect the survival of organisms in the community. Furthermore, anthropogenic changes in habitat conditions increase the range of conditions to which organisms must respond.

## I. THE PHYSICAL TEMPLATE

### A. Biomes

Global patterns of temperature and precipitation, which reflect the interaction between latitude, global atmospheric and oceanic circulation patterns, and topography, establish a regional template of physical conditions that support characteristic community types, called **biomes** (Fig. 2.1) (Finch and Trewartha 1949). Latitudinal gradients in temperature from Earth's equator to its poles define the tropical, subtropical, temperate and arctic zones. Precipitation patterns overlay these temperature gradients. Warm, humid air rises in the tropics, drawing air from higher latitudes into this equatorial convergence zone. The rising air cools and condenses moisture, resulting in a band of high precipitation and, hence, the tropical rainforests centered on the Equator. The cooled, dried air flows away from the equatorial zone and warms as it descends in the “horse latitudes” centered around 30° N and S. These latitudes are dominated by arid grassland and desert ecosystems because of high evaporation rates in warm dry air. Airflow at these latitudes diverges to the equatorial convergence zone and to similar convergence zones at about 60° N and S latitudes. Rising air at these latitudes creates bands of relatively high precipitation and



**FIG. 2.1** Global distribution of the major terrestrial biomes. The distribution of biomes is affected by latitude, global atmospheric and oceanic circulation patterns, and major mountain ranges. Modified from Finch and Trewartha (1949) by permission from McGraw-Hill and E. Odum (1971) with permission from Elsevier.

low temperature that support boreal forests. These latitudinal gradients in climate restrict the distribution of organisms on the basis of their tolerance ranges for temperature and moisture. No individual species is capable of tolerating the entire range of tropical to arctic temperatures, or desert to mesic moisture conditions.

Mountain ranges interact with oceanic and atmospheric circulation patterns to modify latitudinal patterns of temperature and precipitation. Mountains force airflow upward, causing cooling, condensation and precipitation on the windward side (Fig. 2.2). Drier air descends on the leeward side where it gains moisture through evaporation. This orographic effect leads to development of mesic environments on the windward side and arid environments on the leeward side of mountain ranges. Mountains are characterized by elevational gradients of temperature, moisture, and atmospheric conditions, i.e., lower elevations tend to be warmer and drier, whereas higher elevations are cooler and moister. Concentrations of oxygen and other gases decline with elevation, so that species occurring at higher elevations must be capable of surviving at low gas concentrations. The montane gradient is much shorter than the corresponding latitudinal gradient, with the same temperature change occurring in a 1000 m difference in elevation or an 880 km difference in latitude. Hence, the range of habitat conditions that occur over a wide latitudinal gradient occur on a smaller scale in montane areas.

The relatively distinct combinations of temperature and precipitation that prevail (MacMahon 1981) determine the assemblage of species capable of surviving, and defining, the characteristic community type, i.e., tundra, temperate deciduous forest, temperate coniferous forest, tropical rain forest, tropical dry forest, grassland, savanna, chaparral and desert biomes. Representative terrestrial biomes and their seasonal patterns of temperature and precipitation are shown in Figs. 2.3 and 2.4.



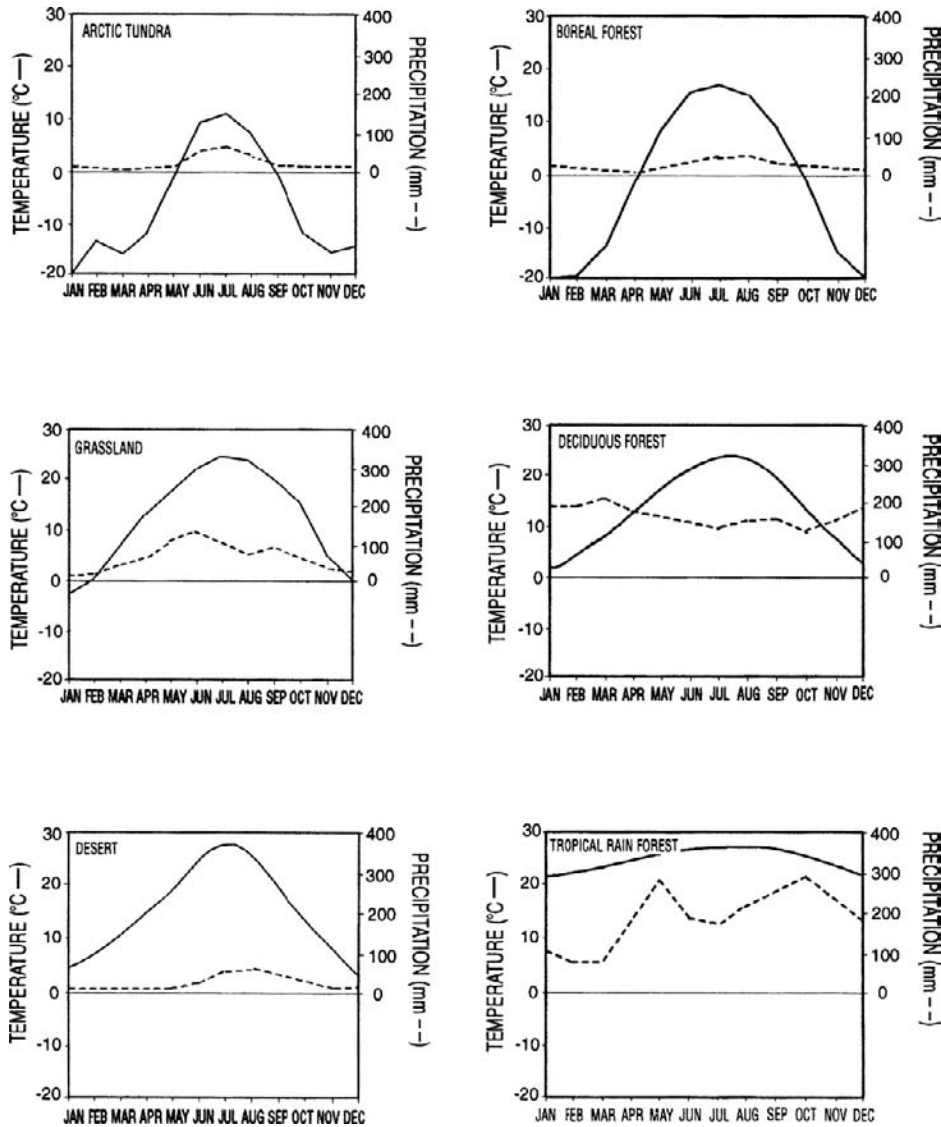
**FIG. 2.2** Orographic effect of mountain ranges. Interruption of airflow and condensation of precipitation on the windward side and clear sky on the leeward side of Mt. Hood, Cascade Mountains, Oregon, U.S.

Habitat conditions in terrestrial biomes are influenced further by topographic relief, substrate structure and chemistry, and exposure to wind. For example, topographic relief creates gradients in solar exposure and soil drainage, as well as in temperature and moisture, providing local habitats for unique communities. Local differences in substrate structure and chemistry may limit the ability of many species of plants and animals, which are generally characteristic of the surrounding biome, to survive. Some soils (e.g., sandy loams) are more fertile or more conducive to excavation than others; serpentine soils and basalt flows require special adaptations for survival by plants and animals. Insects that live in windy areas, especially alpine tundra and oceanic islands, often are flightless as a result of selection against individuals blown away in flight. The resulting isolation of populations results in rapid speciation.

Aquatic biomes are formed by topographic depressions and gradients that create zones of standing or flowing water. Aquatic biomes vary in size, depth, flow rate, and marine influence, i.e., lakes, ponds, streams, rivers, estuaries, and tidal marshes (Fig. 2.5). Lotic habitats often show considerable gradation in temperature and solute concentrations with depth. Because water has high specific heat, it changes temperature slowly relative to air temperature. However, because water is most dense at 4°C, changes in density with temperature result in a seasonal stratification of water temperature. Thermal stratification develops in the summer, as the surface of standing bodies of water warms and traps cooler, denser water below the thermocline (the zone of rapid temperature change), and again in the winter, as freezing water rises to the surface, trapping warmer and denser water below the ice. During fall and spring, changing surface temperatures result in the mixing of water layers and the movement of oxygen and nutrients throughout the water column. Hence, deeper zones in aquatic habitats show relatively



**FIG. 2.3** Examples of ecosystem structure in representative terrestrial biomes: A) tundra (alpine) (western U.S.), B) desert shrubland (southwestern U.S.), C) grassland (note termite mounds in foreground; South Africa), D) tropical savanna (South Africa), E) boreal forest (northwestern U.S.), F) temperate deciduous forest (southeastern U.S.), and G) tropical rain forest (northern Panamá). Photos C and D courtesy of C.A.S. Schwalter.



**FIG. 2.4** Seasonal variation in temperature and precipitation at sites representing major biomes. Data from van Cleve and Martin (1991).

little variation in temperature, allowing aquatic insects to continue development and activity throughout the year, even in temperate regions.

Habitat conditions in aquatic biomes are influenced further by substrate structure and chemistry, by the amount and chemistry of regional precipitation, and by the characteristics of surrounding terrestrial communities, including conditions upstream. Substrate structure and chemistry determine flow characteristics (including turbulence), pH, and inputs of nutrients from sedimentary sources. Amount and chemistry of regional precipitation determine the regularity of water flow and inputs of atmospheric gases and nutrients. Characteristics of surrounding communities determine the degree of exposure to sunlight and the character and condition of allochthonous inputs of organic matter and sediments.

## B. Environmental Variation

Physical conditions vary seasonally in most biomes (Fig. 2.4). Temperate ecosystems are characterized by obvious seasonality in temperature, with cooler winters and warmer summers, and also may show distinct seasonality in precipitation patterns, resulting from seasonal changes in the orientation of the Earth's axis relative to the sun. Although tropical ecosystems experience relatively constant temperatures, precipitation often shows pronounced seasonal variation (Fig. 2.4). Aquatic habitats show variation in water level and circulation patterns related to seasonal patterns of precipitation and evaporation. Seasonal variation in circulation patterns can result in stratification of thermal layers and water chemistry in lotic systems. Intermittent streams and ponds may disappear during dry periods or when evapotranspiration exceeds precipitation.

Physical conditions also vary through time as a result of irregular events. Changes in global circulation patterns of air or water are particularly important. For example, the east–west gradient in surface water temperature in the southern Pacific diminishes in some years, altering oceanic and atmospheric currents globally; the El Niño/southern oscillation (ENSO) phenomenon (Rasmussen and Wallace 1983, Windsor 1990). Particularly strong El Niño years, e.g., 1982–83 and 1997–98, have been characterized by extreme



**FIG. 2.5** Examples of aquatic biomes: A) stream (western U.S.), B) beaver pond (western U.S.), C) swamp (southern U.S.), D) coastal saltmarsh (southeastern U.S.), E) lake (Hungary). Photo D courtesy of S.D. Senter.



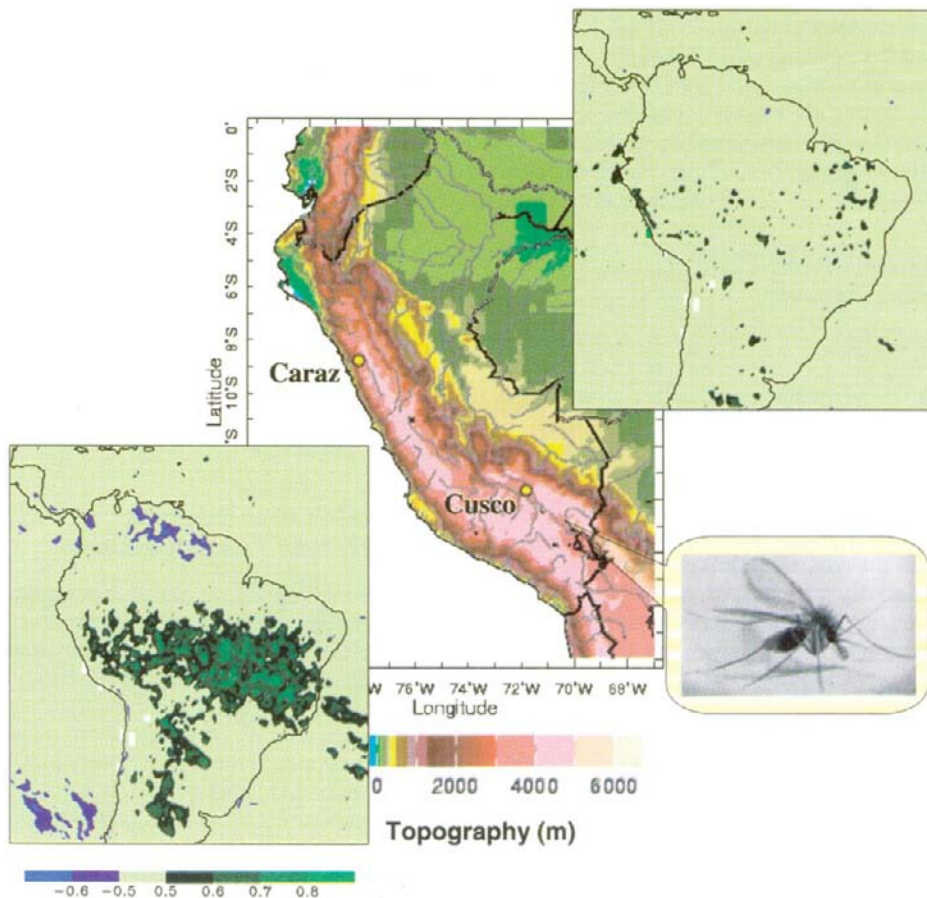
drought conditions in some tropical ecosystems, and severe storms and wetter conditions in some higher latitude ecosystems. Seasonal patterns of precipitation can be reversed, i.e., drier wet season and wetter dry season. The year following an El Niño year may show a rebound; an opposite but less intense effect (La Niña). Windsor (1990) found a strong positive correlation between El Niño index and precipitation during the preceding year in Panama. Precipitation in Panama typically is lower than normal during El Niño years, in contrast to the greater precipitation accompanying El Niño in Peru and Ecuador (Windsor 1990, J. Zhou et al. 2002).

Many insects are sensitive to the changes in temperature and moisture that accompany such events. Stapp et al. (2004) found that local extinction of black-tailed prairie dog, *Cynomys ludovicianus*, colonies in the western Great Plains of North America was significantly greater during El Niño years, due to flea-transmitted plague, *Yersinia pestis*, which spreads more rapidly during warmer, wetter conditions (Parmenter et al. 1999). Similarly, J. Zhou et al. (2002) reported that extremely high populations of sand flies, *Lutzomyia verrucarum*, were associated with El Niño conditions in Peru, resulting in a near doubling of human cases of bartonellosis, an emerging, vector-borne, highly fatal infectious disease in the region (Fig. 2.6). Regional drying triggers outbreaks of many herbivorous species (van Bael et al. 2004).

Solar activity, such as solar flares, may cause irregular departures from typical climatic conditions. Current changes in regional or global climatic conditions also may be the result of deforestation, desertification, fossil fuel combustion and other anthropogenic factors that affect albedo, global circulation patterns and atmospheric concentrations of CO<sub>2</sub>, other greenhouse gases and particulates. Characteristic ranges of tolerance to climatic factors determine the seasonal, latitudinal and elevational distributions of species, and the potential changes in distributions that may occur as a result of changing climate.

Terrestrial and aquatic biomes differ in the type and extent of variation in physical conditions. Terrestrial habitats are sensitive to changes in air temperature, wind speed, relative humidity, and other atmospheric conditions. Aquatic habitats are relatively buffered from sudden changes in air temperature, but are subject to changes in flow rate, depth, and chemistry, especially changes in pH and concentrations of dissolved gases, nutrients, and pollutants. Vegetation cover insulates the soil surface and reduces albedo, thereby reducing diurnal and seasonal variation in soil and near-surface temperatures (J. Foley et al. 2003a). Hence, desert biomes with sparse vegetation cover typically show the widest diurnal and seasonal variation in physical conditions. Areas with high proportions of impervious surfaces (such as roads, roofs, parking lots) greatly alter conditions of both terrestrial and aquatic systems by increasing albedo and precipitation runoff (Elvidge et al. 2004).

Physiological tolerances of organisms, including insects, generally reflect the physical conditions of the biomes in which they occur. For instance, insects associated with the tundra biome tolerate a lower range of temperatures than do insects associated with tropical biomes. The upper threshold temperature for survival of a tundra species might be the lower threshold temperature for survival of a tropical species. Similarly, insects characterizing mesic or aquatic biomes generally have less tolerance for desiccation than do insects characterizing xeric biomes. However, species characterizing temporary streams or ponds may have adapted mechanisms to enable them to withstand desiccation during dry periods (Batzer and Wissinger 1996). Some species show greater capacity for adapting to changing environmental conditions than do others, especially to the rapid changes which result from anthropogenic activity. Such species may be predisposed to adapt to rapid changes because of evolution in frequently disturbed ecosystems.

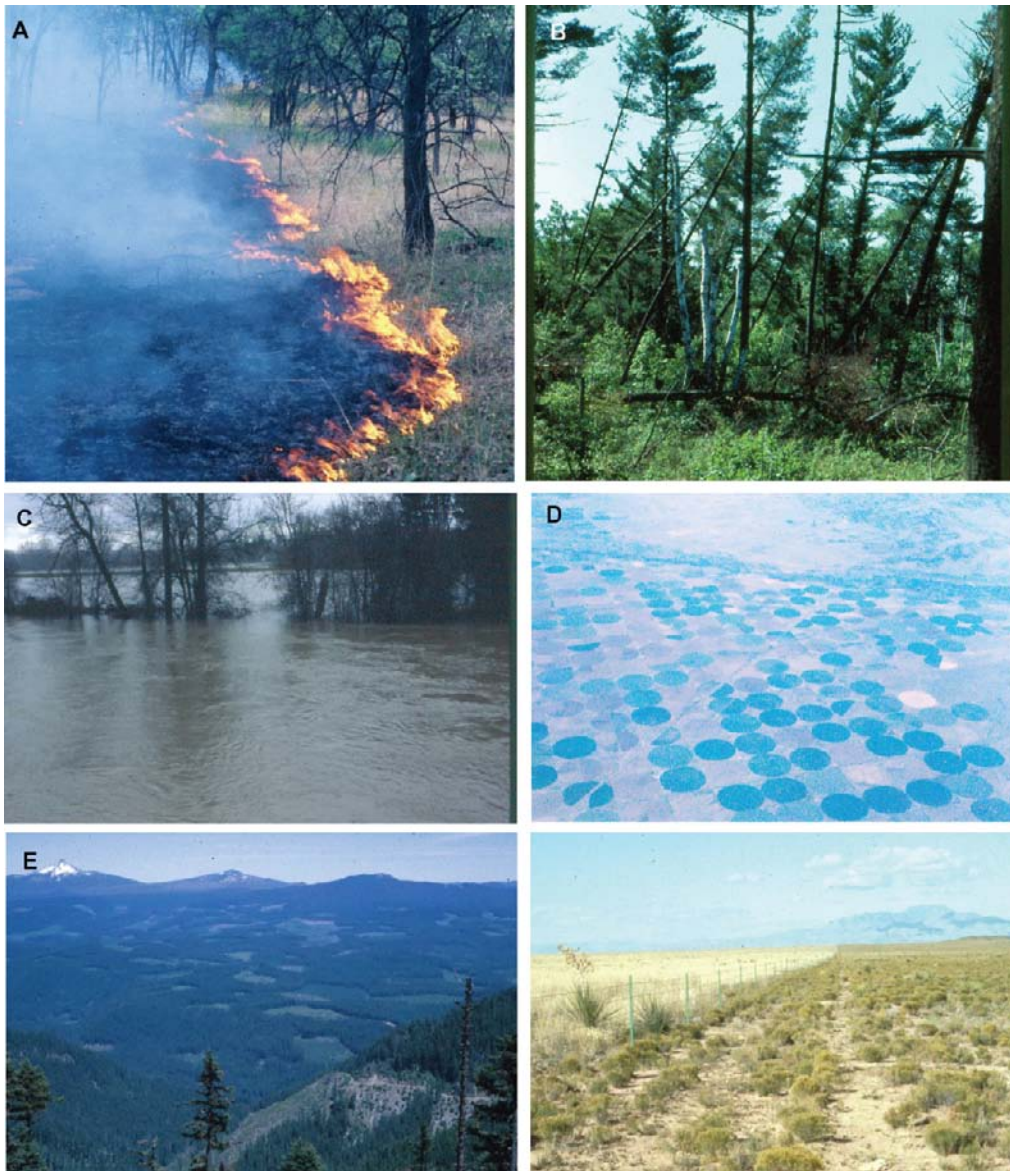


**FIG. 2.6** Topography of Peru (center), comparison of TRMM TMI rainfall correlations at Cuzco (lower left) and Caraz (upper right) relative to their surroundings, and the sand fly, *Lutzomyia verrucarum*, vector of bartonellosis (lower right) that shows increased spread associated with higher rainfall during El Niño events. From J. Zhou et al. (2002) by permission from the American Geophysical Union.

Bradshaw and Holzapfel (2001) and Mathias et al. (2007) found that the genetically-controlled photoperiodic response of the pitcher-plant mosquito, *Wyeomyia smithii*, has shifted toward shorter, more southern daylengths as growing seasons have become longer. This shift was detectable over time intervals as short as five years. Faster evolutionary response has occurred in northern populations, where selection for response to seasonal change in photoperiod is stronger and genetic variation was greater, compared to the southern populations. Therefore, *W. smithii* represents an example of genetic differentiation of a seasonality trait that is consistent with an adaptive evolutionary response to recent global warming.

### C. Disturbances

Within biomes, characteristic abiotic and biotic factors interact to influence the pattern of disturbances, relatively discrete events that alter ecosystem conditions, and create a



**FIG. 2.7** Natural disturbances include A) fire, especially in grasslands and savannas (north central U.S.), B) storms (north central U.S.), and C) floods (northwestern U.S.). Anthropogenic disturbances include D) arid land conversion to agriculture use (center-pivot irrigation, western U.S.), E) forest harvest fragmentation (northwestern U.S.), and F) overgrazing and desertification (right of fence, compared to natural grassland on left; southwestern U.S.). Photo F courtesy of D.C. Lightfoot.

finer-scale landscape mosaic of patches with different disturbance and recovery histories (Harding et al. 1998, Schowalter et al. 2003, Willig and Walker 1999). Disturbances, such as fire, storms, drought, flooding, anthropogenic conversion, etc. (Fig. 2.7), alter vertical and horizontal gradients in temperature, moisture, and air or water chemistry (T. Lewis 1998, P. White and Pickett 1985), significantly altering the abiotic and biotic

conditions to which organisms are exposed (Agee 1993, Schowalter 1985, Schowalter and Lowman 1999).

Disturbances can be characterized by several criteria that determine their effect on various organisms (see Walker and Willig 1999, P. White and Pickett 1985). Disturbance **type**, such as fire, drought, flood, or storm determines which ecosystem components will be most affected. Above-ground vs. below-ground species or terrestrial vs. aquatic species are affected differently by fire vs. flood. **Intensity** is the physical force of the event, whereas **severity** represents the effect on the ecosystem. A fire or storm of given intensity, based on temperature or wind speed, will affect organisms differently in a grassland than it will in a forest. **Scale** is the area affected by the disturbance and determines the rate at which organisms re-colonize the interior portions of the disturbed area. **Frequency** is the mean number of events per time period; **reliability** is measured as the inverse of variability in the time between successive events (recurrence interval).

Insects show a variety of adaptations to particular disturbance types. Some species respond positively, others negatively to particular disturbances, based on adaptive characteristics (Cleary and Grill 2004, E. Evans 1988, Gandhi et al. 2007, Hanula and Wade 2003, Paquin and Coderre 1997, Schowalter 1985, Schowalter et al. 1999, Wikars and Schimmel 2001). For example, Paquin and Coderre (1997) compared forest floor arthropod responses to forest clearing vs. fire. Decomposers were less abundant, whereas predators were more abundant in cleared plots, relative to undisturbed plots. Arthropod abundance was reduced by 96% following experimental fire, but some organisms survived due to their occurrence in deeper soil levels, or to the patchy effect of fire. Abundances of some species differed between cleared and burned plots. Grimbacher and Stork (2009) reported that beetle responses to cyclone disturbance in tropical rainforest in Australia reflected their adaptations to moisture, with more xerophilic species increasing in abundance and mesophilic species decreasing in abundance following canopy opening and general drying of the forest.

Disturbances vary in intensity and severity. A low-intensity ground fire affects primarily surface-dwelling organisms, many of which may be adapted to this level of disturbance, whereas a high-intensity crown fire can destroy a large proportion of the community. Plant species capable of withstanding low-to-moderate windspeeds may topple at high wind speeds (Canham et al. 2010). Hurricane winds damage large areas of forest and can virtually eliminate many arthropods (Koptur et al. 2002, Willig and Camilo 1991).

Disturbances range in scale from local to global. Local disturbances affect the patchwork of communities that compose an ecosystem; global disturbances such as El Niño/La Niña events have far-reaching effects on climate fluctuation. Less mobile insects may require longer periods to recolonize large disturbed areas (Knight and Holt 2005). However, the edges of disturbed areas may provide unique resources, e.g., forest understory species eliminated from the burned area but able to exploit the higher light available at the edge, that favor insect herbivores at the edge (Knight and Holt 2005).

Frequency and reliability of recurrence, with respect to generation times of characteristic organisms, of a particular disturbance type are the most important factors driving directional selection for adaptation to disturbance, e.g., traits that confer tolerance (resistance) to fire or flooding. Effects of disturbances may be most pronounced in ecosystems, such as mesic forests and lakes, which have the greatest capacity to modify abiotic conditions and, therefore, have the lowest exposure and species tolerances to sudden or extreme departures from nominal conditions.

Ecosystems can be subject to various combinations of disturbance type, frequency and intensity. For example, over a 20 yr period the rainforest in eastern Puerto Rico

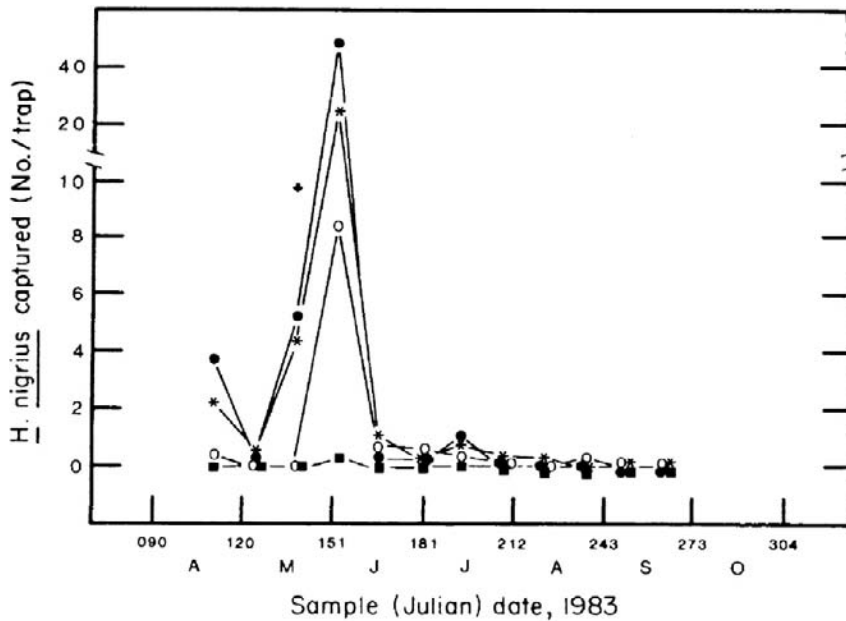
experienced two major hurricanes (Hugo 1989 and Georges 1998), several minor hurricanes (Bertha, Hortense and Marilyn 1996 and Debbie 2001), a number of tropical storms, a major drought (1994–1995, during which precipitation was only 41% of annual mean) and several minor droughts (1991, 1996, 2001 and 2003), as well as an overall drying trend of 2 mm yr<sup>-1</sup> since 1988 (Heartsill-Scalley et al. 2007).

Anthropogenic disturbances have become a pervasive environmental factor, and their effects may differ from those of natural disturbances. Such disturbances range from local conversion of ecosystems, such as altered streamflow pattern (e.g., sedimentation or stream scour resulting from coffer dam construction for logging), to regional effects of introduced species, to effects of global water and air pollution and fossil fuel combustion. The degree of ecosystem fragmentation resulting from changes in land use is unprecedented in nature, and seriously affects population distribution by reducing habitat area, isolating demes and interfering with dispersal, thus potentially threatening species incapable of surviving in, or escaping, increasingly inhospitable landscapes (Samways et al. 1996, Shure and Phillips 1991, A. Suarez et al. 1998, Summerville and Crist 2001).

Individual insects have specific tolerance ranges to abiotic conditions that dictate their ability to survive local conditions, but they may be exposed during some periods to lethal extremes of temperature, water availability or other factors. Variable ecosystem conditions typically select for wider tolerance ranges than do more stable conditions. Although abiotic conditions can affect insects directly (e.g., burning, drowning, particle blocking of spiracles), they also have indirect effects, through changes in resource quality and availability and exposure to predation or parasitism (e.g., Alstad et al. 1982, K. Miller and Wagner 1984, Mopper et al. 2004, Shure and Wilson 1993). Population size and the degree of genetic heterogeneity within populations affect the number of individuals that can survive altered conditions (G. Bell and Gonzalez 2009). As habitat conditions change, intolerant individuals disappear, leaving a higher frequency of genes for tolerance of the new conditions in the surviving population.

Some species are favored by altered conditions, whereas others may disappear, depending on particular adaptations (e.g., Buddle et al. 2006, Hirao et al. 2008, Mertl et al. 2009, Moretti and Legg 2009). De Mazancourt et al. (2008) suggested that high biodiversity increases the likelihood that some species have genotypes that are adapted to the new conditions. Arrival of adapted colonists of various species from other areas is likely to augment community recovery. Even within families and genera, individual species may respond quite differently. Among Hemiptera, some scale insects increase in numbers and others decline following forest canopy disturbance resulting from hurricane winds (Schowalter and Ganio 2003). Root bark beetles (e.g., *Hylastes nigrinus*) are attracted to chemicals emanating from exposed stump surfaces and advertising suitable conditions for brood development. They become more abundant following forest thinning (Fig. 2.8) (Witcosky et al. 1986), whereas stem-feeding bark beetles (e.g., *Dendroctonus* spp.) are sensitive to tree spacing and become less abundant in thinned forests (Amman et al. 1988, Sartwell and Stevens 1975, Schowalter and Turchin 1993).

Hanula and Wade (2003) found that abundances of most forest floor species (especially predators) were reduced by prescribed burning, and reduced more by annual than by biennial or quadrennial burning, but a few species (especially detritivores) increased in abundance with more frequent burning. Litter-dwelling ants are vulnerable to seasonal flooding in Amazonian forests (Mertl et al. 2009). Specialist predators were virtually eliminated by flooding; however, one *Hypoponera* species was adapted to a high degree of flooding, increasing in abundance with its frequency and duration.



**FIG. 2.8** Changes in abundance of a root bark beetle, *Hylastes nigrinus*, in undisturbed, 12-yr-old plantations (black squares) of Douglas-fir and plantations thinned in September 1982 (asterisks), January 1983 (black circles) or May 1983 (white circles) in western Oregon. Arrow indicates time of thinning in May 1983. From Witcosky et al. (1986), courtesy of the Research Council of Canada.

Matthaei and Townsend (2000) reported that abundances of mobile stream insects reflected local scouring of gravel streambeds in New Zealand for at least two months. Three dominant insect taxa were more abundant in patches that retained sediment, whereas isopods were more abundant in scoured patches.

Increasing disturbance frequency or intensity generally reduces species diversity (Haddad et al. 2008). Reice (1985) experimentally disturbed benthic invertebrate communities in a low order stream in the eastern U.S. by tumbling cobbles in patches of stream bottom 0, 1 or 2 times in a six-week period. Most insect and other invertebrate taxa decreased in abundance with increasing disturbance. Two invertebrate taxa increased in abundance following a single disturbance, but no taxa increased in abundance with increasing disturbance. However, all populations rebounded quickly following disturbance, suggesting that these taxa were all adapted to this disturbance.

Timing of disturbances, relative to developmental stage, also affects insect responses. For example, Voelz et al. (1994) reported that caddisfly species surviving a period of increased water temperature (+ 4–5°C, from surface water release over a dam) were those with abundant terrestrial adults during this period and those with broad thermal tolerance. On the other hand, Martin-R. et al. (1999) reported that experimental fires during different developmental stages of spittlebug, *Aeneolamia albofasciata*, in buffelgrass, *Cenchrus ciliaris*, grassland in Sonora, Mexico, eliminated spittlebugs for at least four years after burning, regardless of their developmental stage at the time of burning.

The particular disturbances characterizing an ecosystem, together with prevailing climate, constitute a filter that limits the ability of intolerant species to persist (J. Chase 2007). For example, frequent fire prevents trees from becoming established, or persisting,

in grasslands, as demonstrated by tree encroachment into grasslands when fire is excluded. “Tolerant” species typically are able to withstand the effects of disturbance, e.g., through desiccation-resistant life stages, or they are able to recolonize disturbed areas quickly following disturbance. Insects are often the most obvious cause of plant decline and replacement by more tolerant species, but insect outbreaks typically reflect responses by adapted species to disturbance-induced plant stress or density (Breshears et al. 2005, Schowalter 1985 see Chapters 3, 6 and 12).

After a disturbance, populations may recover to their pre-disturbance condition at rates that reflect the extent of change and the size of the disturbed area. Recovery can be as quick as a few months for rapidly-reproducing species or assemblages, such as many insects (Gandhi et al. 2007, Matthaei and Townsend 2000, Murdock et al. 2010, Reice 1985) or many years to centuries for long-lived, slowly-reproducing species or assemblages (see Chapter 10).

Disturbances that disrupt interactions among species may slow recovery. For example, factors that delay recovery of plant communities also influence recovery of habitat conditions and rates of insect recovery. Overall diversity and abundance in stream invertebrate communities did not differ between young (30–40 year-old) and old-growth (500 year-old) forests in Oregon, U.S., but the deciduous riparian vegetation (with seasonal litterfall and canopy opening) which characterized the young forest continued to affect stream invertebrate species composition, e.g., higher densities of stoneflies, compared to streams in old-growth coniferous forest, for many years (Frady et al. 2007). Furthermore, disturbance-induced changes in interaction strength among species (see Chapters 8 and 9) can persist for longer than changes in species presence or abundance. Tylianakis et al. (2007) reported that tropical forest conversion to agricultural uses altered the evenness of interactions among cavity-nesting bees and wasps and their parasitoids in ways that focused parasitism on the most abundant bee species in the most modified agricultural systems, potentially affecting pollination and biological control services. Benstead et al. (2007) reported that recovery of aquatic insect populations in Arctic streams was delayed by a disturbance-induced shift in dominance of primary producers from algae to bryophytes, although algal biomass recovered to pre-disturbance levels within two years.

In some cases, insect responses to disturbance become the agent for further changes in community structure. Bark beetle populations in injured conifers can reach sizes that are capable of killing surrounding uninjured trees (Schowalter and Turchin 1993). Elderd (2006) and Elderd and Doak (2006) reported that a common riparian plant, *Mimulus guttatus*, is favored by flooding disturbance, but manipulative experiments demonstrated that increased herbivory by grasshoppers following flood events significantly reduced plant survival.

If the disturbance-free interval is shorter than the time needed for recovery, then the altered community may persist. Conversely, anthropogenic alteration of disturbance dynamics, such as fire suppression, also causes changes in community composition and structure, affecting habitat conditions for associated insects. Because the survival and reproduction of individual insects determines population size and distribution, and has significant effects on community and ecosystem processes, the remainder of this chapter focuses on physiological and behavioral characteristics that affect individual responses to variable abiotic conditions.

## II. SURVIVING VARIABLE ABIOTIC CONDITIONS

Insects are particularly vulnerable to changes in temperature, water availability, and air or water chemistry because of their relatively large ratios of surface area to volume.

However, many insects can live easily within suitable microsites that buffer exposure to environmental changes. Insects in aquatic environments, or deep in soil or woody habitats may be relatively protected from large changes in air temperature and relative humidity (e.g., Curry 1994, Seastedt and Crossley 1981a). High moisture content of soil can mitigate heat penetration and protect soil fauna.

Most insects are subject to environmental variability that will include periods of potentially lethal or stressful abiotic conditions (Shelford 1918). Therefore, maintaining optimal body temperature, water content and chemical processes is a challenge for survival in variable environments. Insects possess a remarkable variety of physiological and behavioral mechanisms for surviving in such conditions.

Adaptive physiological responses can mitigate exposure to suboptimal conditions. For example, diapause is a general physiological mechanism for surviving seasonally adverse conditions, typically in a resistant stage, such as the pupa of holometabolous insects. Our understanding of the genetic and molecular basis for physiological processes has increased dramatically in the past 20 years. Diapause induction and termination are controlled by cues such as photoperiod and degree-day accumulation (daily degrees above a threshold temperature  $\times$  number of days) which induce chemical signals from the brain (Denlinger 2002, Giebultowicz 2000, Giebultowicz and Denlinger 1986). In particular, photoreceptors that distinguish day from night trigger expression of genes that measure and accumulate information on day and/or night length and produce proteins that induce diapause (Hardie 2001). Denlinger (2002) and Giebultowicz (2000) reported that photoperiod affects patterns of expression, whereas temperature affects the amount, of several clock mRNAs (cryptochrome, *cry*, clock, *clk*, period, *per*, and timeless, *tim*) that also regulate circadian rhythms. The relative amounts of these mRNAs show distinct trends from long, warm days to shorter, cooler days, but their precise role in triggering the onset of diapause remains unknown (Denlinger 2002, Goto and Denlinger 2002). Various antibiotic proteins also are produced only during diapause, apparently to prevent infection from tissue exposure to gut microorganisms while gut tissues are being reorganized (P. Dunn et al. 1994, K. Y. Lee et al. 2002). Diapause termination often requires a minimum duration of freezing temperatures, or other factors, that maximize synchronization of development with seasonally suitable conditions (Ruberson et al. 1998). Beaver et al. (2002) reported that *Drosophila* males with mutations in the genes that govern circadian rhythm produced fewer offspring than did wild flies, demonstrating the importance of the genes controlling periodicity. Nevertheless, exposed insects often are killed by sudden or unexpected changes in temperature, moisture, or chemical conditions of the habitat. Even diapausing insects suffer high mortality due to a combination of temperature, disease, predation, or other factors (Ruberson et al. 1998).

Behavior represents a more flexible means of responding to environmental variation, compared to physiology, because an animal can respond actively to sensory information to avoid or mitigate lethal conditions. Mobile insects have an advantage over sessile species in avoiding or mitigating exposure to extreme temperatures, water availability, or chemical conditions. Limited mobility often is sufficient within steep environmental gradients. Many small, flightless litter species need move by only a few millimeters, vertically within the soil profile, to avoid lethal temperatures and desiccation at the surface, following fire or vegetation removal (Seastedt and Crossley 1981a). Some species choose protected habitats, prior to entering diapause, to reduce their vulnerability to potential disturbances. K. Miller and Wagner (1984) reported that pandora moth, *Coloradia pandora*, pupae in a ponderosa pine, *Pinus ponderosa*, forest were significantly more abundant



on the forest floor in areas with open canopy and sparse litter than in areas with closed canopy and deeper litter. Although other factors also differ between these microhabitats, avoidance of accumulated litter may represent an adaptation to survive frequent ground fires in this ecosystem. In addition, mobile insects may be able to escape disturbed patches and often can detect and colonize suitable patches within variable environments (D. Johnson 2004).

Although small body size limits the ability to regulate body temperature and water content, many insects are capable of at least limited homeostasis through physiological and/or behavioral mechanisms. Some insects also must deal with variability in chemical or other abiotic conditions.

### A. Thermoregulation

Insects, as well as other invertebrates, are **heterothermic**, meaning that their body temperatures are determined primarily by the ambient temperature. Rates of metabolic activity (hence, energy and carbon flux) generally increase with temperature. Developmental rate and processes reflect this temperature dependence, but at least some species can regulate their body temperature to some degree via physiological or behavioral responses.

Insect species show characteristic ranges in temperatures that are suitable for their activity. Aquatic ecosystems have relatively consistent temperatures, but insects in terrestrial ecosystems can experience considerable temperature fluctuation, even on a daily basis. Tolerance limits reflect individual age or maturity, size, color, previous exposure, extent of water reserves, and other factors. For example, pigmented workers of the desert harvester termite, *Hodotermes mossambicus*, forage above-ground throughout the year, over a temperature range of about 8–45°C, whereas unpigmented workers are never seen above-ground (J. Mitchell et al. 1993). Meisel (2006) reported that the army ant, *Eciton burchellii*, is restricted to forest fragments in Costa Rica because workers survived <3 min at 51°C (the midday temperature of surrounding pastures) and only 18 min at 43°C.

As a group, insects can survive at temperatures from well below freezing to 40–50°C (Whitford 1992), depending on adapted tolerance ranges and acclimation (preconditioning). Some insects occurring at high elevations die at a maximum temperature of 20°C, whereas insects from warm environments often die at higher minimum temperatures. Chironomid larvae living in hot springs survive water temperatures of 49–51°C (R. Chapman 1982).

In general, developmental rate of heterotherms increases with temperature. Both terrestrial and aquatic insects respond to the accumulation of thermal units (the sum of degree-days above a threshold temperature) (Baskerville and Emin 1969, Ward 1992, Ward and Stanford 1982). Degree-day accumulation can be similar under different conditions, e.g., mild winter/cool summer and cold winter/hot summer, or quite different along elevational or latitudinal gradients. Anthropogenic conditions can significantly alter thermal conditions, especially in aquatic habitats. Discharge of heated water, artificial mixing of thermal strata, impoundment, diversion, regulation of water level and flow, and canopy opening in riparian zones, through harvesting or grazing, severely modify the thermal environment for aquatic species and favor heat-tolerant over heat-intolerant individuals and species (M. Stone and Wallace 1998, Ward and Stanford 1982).

Many insects survive temperatures as low as –30°C, and some Arctic species survive below –50°C (N. Hadley 1994, Lundheim and Zachariassen 1993, B. Sinclair et al. 2003).

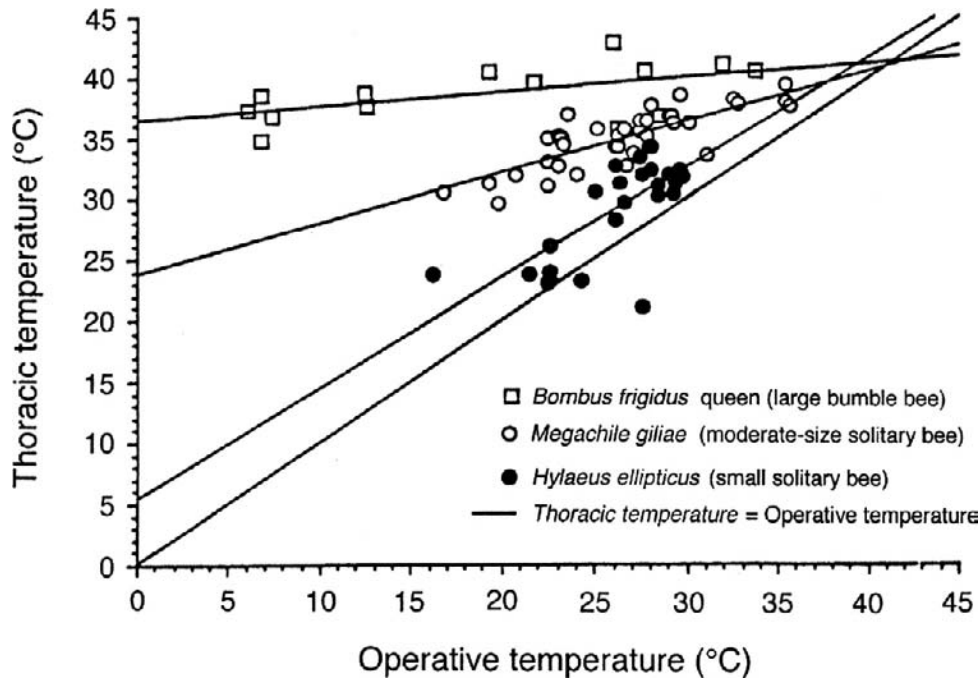
Freeze tolerant species can survive ice formation in extracellular fluids but not in intracellular fluids (N. Hadley 1994, Lundheim and Zachariassen 1993). Ice nucleating lipids and/or lipoproteins inhibit supercooling to ensure that ice forms in extracellular fluids at relatively high temperatures, i.e., above  $-10^{\circ}\text{C}$  (N. Hadley 1994, B. Sinclair et al. 1999). Extracellular freezing draws water osmotically from cells, thereby dehydrating cells and lowering the freezing point of intracellular fluids (N. Hadley 1994). B. Sinclair et al. (1999) showed that temperatures at which supercooling and ice nucleation occurred were different among alpine, subalpine and lowland species and populations of the New Zealand weta, *Hemidiena* spp., in ways which suggested that freeze tolerance among species in this genus is not a specific adaptation to an alpine climate.

Other species have various mechanisms for lowering their freezing or supercooling points. Voiding the gut at the onset of cold conditions may prevent food particles from serving as nuclei for ice formation. Similarly, non-feeding stages may have lower supercooling points than do feeding stages (N. Hadley 1994, Kim and Kim 1997). Some insects prevent freezing at temperatures as low as  $-50^{\circ}\text{C}$  by producing high concentrations (up to 25% fresh weight) of alcohols and sugars, such as glycerol, glucose, and trehalose, as well as peptides and proteins, in the hemolymph (N. Hadley 1994, Lundheim and Zachariassen 1993). In many cases, a multicomponent cryoprotectant system that involves a number of compounds prevents accumulation of potentially toxic levels of any single component (N. Hadley 1994). Cold tolerance varies with life stage, rate of cooling, lowest temperature, and exposure time, and can be enhanced by preconditioning to sublethal temperatures (Kim and Kim 1997, B. Sinclair et al. 1999). Rivers et al. (2000) reported that cold hardiness in a pupal parasitoid, *Nasonia vitripennis*, was enhanced by encasement within the flesh fly host, *Sarcophaga crassipalpi*, and by acquisition of host cryoprotectants, especially glycerol and alanine, during larval feeding.

Many insects can reduce body temperature at high ambient temperatures, above  $45^{\circ}\text{C}$  (Casey 1988, Heinrich 1974, 1979, 1981, 1993). An Australian montane grasshopper, *Kosciuscola*, changes color from black at night to pale blue during the day (Key and Day 1954), thereby regulating heat absorption. Evaporative cooling, through secretion, regurgitation, ventilation, or other means, can lower body temperature by  $5-8^{\circ}\text{C}$  below ambient temperatures when the air is dry (N. Hadley 1994). Prange and Pinshow (1994) reported that both sexes of a sexually dimorphic desert grasshopper, *Poekiloceros bufonius*, depress their internal temperatures through evaporative cooling. However, males lost proportionately more water through evaporation, but retained more water from food, than did the much larger females, indicating that thermoregulation by smaller insects is more constrained by water availability.

Long term exposure to high temperatures requires high body water content or access to water, to avoid desiccation (R. Chapman 1982, N. Hadley 1994). N. Hadley (1994) described experiments demonstrating that males of a Sonoran Desert cicada, *Diceroprocta apache*, maintain evaporative cooling by ingesting xylem water from twigs on which they perch while singing. Although this species has high cuticular permeability, even at non-stressful temperatures, water loss ceases at death, indicating active cuticular pumping of body water. A 0.6g cicada maintaining a temperature differential of  $5^{\circ}\text{C}$  must siphon at least 69mg xylem fluid per hour. Laboratory experiments indicated that maintaining this temperature differential resulted in a 5% increase in metabolic rate over resting levels. These cicadas probably have additional energetic costs associated with rapid extraction and transport of ingested water to the cuticle.

Thermoregulation also can be accomplished behaviorally. Heinrich (1974, 1979, 1981, 1993) and Casey (1988) reviewed studies demonstrating that a variety of insects are capable



**FIG. 2.9** Thoracic temperature of live bees relative to operative temperature, measured with a thermocouple inserted in a freshly-killed bee, equilibrated to ambient temperature, to account for effects of solar radiation and convection on ambient temperature, for representative small, medium and large bee species. Each point represents a measurement for an individual bee. Thermoregulatory capability for each bee species is indicated by respective regression lines and can be compared to the isothermal line (thoracic temperature = operative temperature). From Bishop and Armbruster (1999) with permission from John Wiley & Sons.

of thermoregulation through activities that generate metabolic heat, such as fanning the wings and flexing the abdomen (Figure 2.9). Flight can elevate body temperature 10–30°C above ambient (R. Chapman 1982, Heinrich 1993). A single bumble bee, *Bombus vosnesenskii*, queen can raise the temperature of the nest by as much as 25°C above air temperatures as low as 2°C, even in the absence of insulating materials (Heinrich 1979). Bees also can cool their nests by fanning their wings to increase ventilation (M. Yang et al. 2010).

Insects can sense and often will move within temperature gradients to thermally optimal habitats. Light is an important cue that attracts insects to sources of heat or repels them to darker, cooler areas. Aquatic insects move both vertically and horizontally within temperature gradients to select sites of optimal temperatures (Ward 1992). Terrestrial insects frequently bask on exposed surfaces to absorb heat during early morning or cool periods (Fig. 2.10), and retreat to less exposed sites during warmer periods. Some insects use or construct shelters to trap or avoid heat. Tent caterpillars, *Malacosoma* spp., build silken tents that slow dissipation of metabolic heat and increase colony temperature above ambient (Fig. 2.11) (Fitzgerald 1995, Heinrich 1993). L. Moore et al. (1988) reported that overwintering egg masses and tents of the western tent caterpillar, *Malacosoma californicum*, occurred significantly more often on sides of trees, or isolated trees, exposed to the sun. Tents of overwintering larvae of the arctiid moth, *Lophocampa argentata*, occur almost exclusively in the exposed upper canopy and significantly more often on the south-facing



**FIG. 2.10** Many insects, such as dragonflies, raise their body temperatures by basking. Heat absorption is enhanced by dark coloration and orientation. Photo courtesy of S.D. Senter.

sides of host conifers in western Washington, U.S. (D. Shaw 1998). Other species burrow to depths at which diurnal temperature fluctuation is minimal (Polis et al. 1986). Seastedt and Crossley (1981a) reported significant redistribution of soil/litter arthropods from the upper 5 cm of the soil profile to deeper levels following canopy removal and consequent soil surface exposure and warming in a forested ecosystem.

Some insects regulate body temperature by optimal positioning (Heinrich 1974, 1993). Web-building spiders adjust their posture to control their exposure to solar radiation (Robinson and Robinson 1974). Desert beetles, grasshoppers and scorpions prevent overheating by stiling, i.e., extending their legs and elevating the body above the heated soil surface and by orienting the body to minimize the surface area that is exposed to the sun (Heinrich 1993).

## B. Water Balance

Maintenance of homeostatic water balance also is a challenge for organisms with high ratios of surface area to volume (Edney 1977, N. Hadley 1994). The arthropod exoskeleton is an important mechanism for control of water loss. Larger, more heavily sclerotized arthropods are less susceptible to desiccation than are smaller, more delicate species (Alstad et al. 1982, Kharboutli and Mack 1993).

Arthropods in xeric environments are typically larger, have a thicker cuticle, and secrete more waxes to inhibit water loss, compared to insects in mesic environments (Crawford 1986, Edney 1977, N. Hadley 1994, Kharboutli and Mack 1993). Cuticular lipids with higher melting points might be expected to be less permeable to water loss than are those with lower melting points. Gibbs (2002a) evaluated cuticular permeability with respect to water loss for several arthropod species, and found that all species produced lipids with low melting



**FIG. 2.11** Tent caterpillars, *Malacosoma* spp., and other tent-constructing Lepidoptera, reduce airflow and variation in temperatures within their tents.

points as well as high melting points, tending to increase water loss. Furthermore, lipids with high melting points did not reduce rates of water loss (Gibbs 2002a, Gibbs et al. 2003).

Some species in xeric environments conserve metabolic water (from oxidation of food) or acquire water from condensation on hairs or spines (R. Chapman 1982, N. Hadley 1994). Carbohydrate metabolism, to release bound water, increases several-fold in some insects when subjected to desiccation stress (Marron et al. 2003). Others tolerate water loss of 17–89% of total body water content (Gibbs 2002b, N. Hadley 1994). Dehydration tolerance in *Drosophila* apparently reflects phylogeny rather than adaptation to desert environments (Gibbs and Matzkin 2001). Some insects regulate respiratory water loss by controlling spiracular activity under dry conditions (Fielden et al. 1994, N. Hadley 1994, Kharboutli and Mack 1993). Water conservation is under hormonal control in some species. An antidiuretic hormone is released in desert locusts, *Schistocerca gregaria*, and other species under conditions of water loss (Delphin 1965).

Gibbs et al. (2003) compared the three main water loss pathways among *Drosophila* species from xeric and mesic habitats. Excretory loss was <6% of the total and did not differ among species from different habitats. No consistent relationship was found between cuticular properties and water loss. Cuticular water loss rates did not appear to differ among flies from different habitats. Respiratory water loss differed significantly between

xeric and mesic species. Xeric species of the same size had lower metabolic rates, were less active, and showed a cyclic pattern of CO<sub>2</sub> release, compared to mesic species, indicating adaptation to reduce respiratory loss.

Extreme dehydration may trigger the onset of anhydrobiosis, a physiological state characterized by an absence of free water and of measurable metabolism (N. Hadley 1994, Whitford 1992). Survival during anhydrobiosis requires stabilization of membranes and enzymes by compounds other than water, e.g., glycerol and trehalose, whose synthesis is stimulated by dehydration (N. Hadley 1994). The phenomenon is common among plant seeds, fungi, and lower invertebrates, but among insects only some larval Diptera and adult Collembola have been shown to undergo anhydrobiosis (N. Hadley 1994). Hinton (1960a, b) reported that a chironomid fly, *Polypedilum vanderplancki*, found in temporary pools in central Africa, withstands repeated dehydration to 8% of body water content. At 3% body water content, this midge is capable of surviving temperatures from -270 °C to 100 °C, a range that contrasts dramatically with its tolerance range when hydrated.

Insects and other arthropods are most vulnerable to desiccation at times when a new exoskeleton is forming, i.e., during eclosion from eggs, during molts, and during diapause (Crawford 1978, Willmer et al. 1996). Tisdale and Wagner (1990) found that percentage of sawfly, *Neodiprion fulviceps*, eggs hatched was significantly higher at relative humidities  $\geq 50\%$ . Yoder et al. (1996) reported that slow water loss through the integument and respiration by diapausing fly pupae was balanced by passive water vapor absorption from the air at sufficiently high humidities. The ability of adult insects to regulate water loss may decline with age (Gibbs and Markow 2001).

Insects in diapause at subfreezing temperatures are subject to freeze-drying. Lundheim and Zachariassen (1993) reported that beetles which tolerate ice formation in extracellular fluids have lower rates of water loss than do insects that have supercooled body fluids, perhaps because the hemolymph in frozen beetles is in vapor pressure equilibrium with the surrounding ice, whereas the hemolymph in supercooled insects has a vapor pressure that is higher than the environment.

On the other hand, some insects must contend with excess water. Termites, ants, and other insects that live underground must survive periods of flooding. Subterranean termite species apparently survive extended periods of inundation by entering a quiescent state; the relative abilities of species to withstand periods of flooding correspond to their utilization of above-ground or below-ground wood resources (Forschler and Henderson 1995).

Insects that ingest liquid food immediately excrete large amounts of water to concentrate dissolved nutrients. Elimination of excess water (and carbohydrates) in sap-feeding Hemiptera is accomplished in the midgut by rapid diffusion across a steep moisture gradient created by a filter loop (R. Chapman 1982). The resulting concentration of sugars in honeydew excreted by phloem-feeding Hemiptera is an important resource for ants, hummingbirds, predaceous Hymenoptera and sooty molds (Dixon 1985, E. Edwards 1982, N. Elliott et al. 1987, Huxley and Cutler 1991). The abundant water excreted by xylem-feeding spittlebugs is used to create the frothy mass that hides the insect. Excretion in some species, such as the blood-feeding *Rhodnius* (Hemiptera) is controlled by a diuretic hormone (Maddrell 1962).

Water balance also can be maintained behaviorally, to some extent, by retreating to cooler or moister areas to prevent desiccation. Burrowing provides access to more mesic subterranean environments (Polis et al. 1986). The small size of most insects makes them vulnerable to desiccation, but also permits habitation within the relatively humid boundary layer around plant or soil surfaces.

Termites construct their colonies to optimize temperature and moisture conditions. Formosan subterranean termites, *Coptotermes formosanus*, prefer nest sites with high moisture availability (Fei and Henderson 1998). Metabolic heat generated in the core of the nest rises by convection into large upper cavities, and diffuses to the sides of the nest, where the air is cooled and gaseous exchange occurs through the thin walls. Cooled air sinks into lower passages (Lüscher 1961). The interior chambers of termite colonies typically have high relative humidities.

### C. Air and Water Chemistry

Air and water chemistry affects insect physiology. Oxygen supply is critical to survival, but may be limited under certain conditions. Airborne or dissolved chemicals can affect respiration and development. Soil or water pH can affect exoskeleton function and other physiological processes. Changes in concentrations of various chemicals, especially those affected by industrial activities, affect many organisms, including insects.

Oxygen supply can limit the activity and survival of aquatic species and also some terrestrial species living in enclosed habitats. Less oxygen can remain dissolved in warm water than in cold water. Stagnant water can undergo oxygen depletion as a result of algal and bacterial respiration (Ward 1992). Some insect species living in oxygen-poor environments have more efficient oxygen delivery systems, such as increased tracheal supply, gills, or breathing tubes that extend to air supply (L. Chapman et al. 2004, R. Chapman 1982). For example, the hemolymph of some aquatic chironomid larvae and endoparasitic fly larvae is unique among insects in containing a hemoglobin that has a higher affinity for oxygen than does mammalian hemoglobin (R. Chapman 1982, Pinder and Morley 1995). Oxygen supply can be enhanced by ventilatory movement, i.e., movement of gills or other body parts to create currents that maintain oxygen supply and reduce the diffusion barrier (Ward 1992). Other species must employ siphon tubes (e.g., mosquito and syrphid fly larvae) or return to the surface (diving beetles) to obtain atmospheric oxygen (L. Chapman et al. 2004). Some wood-boring species must be able to tolerate low oxygen concentrations deep in decomposing wood, although oxygen limitation may occur only in relatively sound wood or water-soaked wood (Hicks and Harmon 2002).

Increased atmospheric CO<sub>2</sub> appears to have little direct effect on insects or other arthropods. However, relatively few insect species have been studied with respect to CO<sub>2</sub> enrichment. Increased atmospheric CO<sub>2</sub> can significantly affect the quality of plant material for some herbivore (Arnone et al. 1995, Bezemer and Jones 1998, Bezemer et al. 1998, Fajer et al. 1989, Kinney et al. 1997, Lincoln et al. 1993, S. Roth and Lindroth 1994) and decomposer species (Grime et al. 1996, Hirschel et al. 1997), although plant response to CO<sub>2</sub> enrichment depends on a variety of environmental factors (e.g., Lawton 1995, Watt et al. 1995, see Chapter 3). In general, leaf chewers compensate for the effects of elevated CO<sub>2</sub> by increasing consumption rates, whereas sap-suckers show reduced development times and increased population size (Bezemer and Jones 1998). Mondor et al. (2005) reported that two color morphs of pea aphids, *Acyrtosiphum pisum*, differed in response to elevated CO<sub>2</sub>. The green genotype responded positively to CO<sub>2</sub> enrichment, but the pink genotype did not, altering genetic frequencies from 1:1 to 9:1 and potentially altering other aspects of aphid life history and interactions. At least some herbivorous species are likely to become more abundant and cause greater crop losses as a result of increased atmospheric CO<sub>2</sub> (Bezemer et al. 1998).

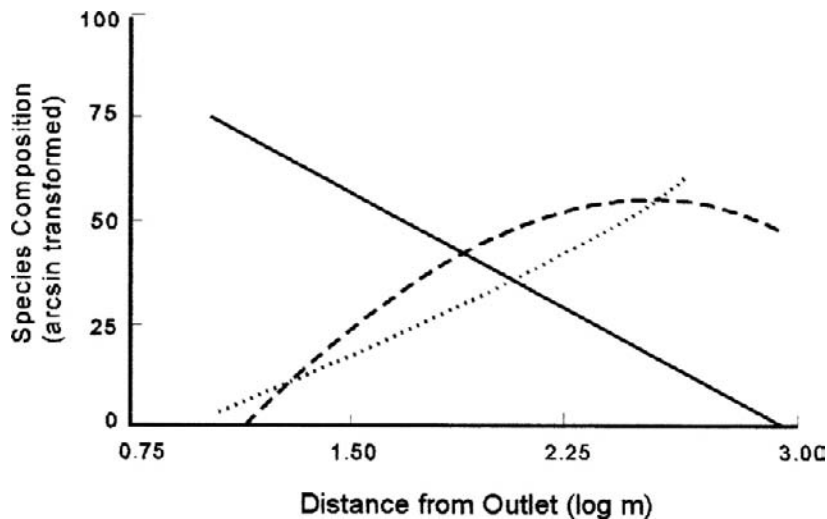
Airborne and dissolved materials can include volatile emissions or secretions from plant, animal, and industrial origin. Fluorides, sulfur compounds, nitrogen oxides, and ozone affect many insect species directly, although the physiological mechanisms of toxicity are not well-known (Alstad et al. 1982, Heliövaara 1986, Heliövaara and Väisänen 1986, 1993, Pinder and Morley 1995). Disruption of epicuticular or spiracular tissues by these reactive chemicals may be involved. Dust and ash kill many insects, apparently because they absorb and abrade the thin epicuticular wax-lipid film that is the principal barrier to water loss. Insects then die of desiccation (Alstad et al. 1982). V.C. Brown (1995) concluded that there is little evidence for direct effects of realistic concentrations of these major air pollutants on terrestrial herbivores, but considerable evidence that many herbivorous species respond to changes in the quality of plant resources, or abundance of predators resulting from exposure to these pollutants. Kainulainen et al. (1994) found that exposure of Scots pine, *Pinus sylvestris*, seedlings to ozone significantly reduced the amounts of starch, and total amino acids at the highest ozone concentration (0.3 ppm), but the other sugars or other secondary compounds were unaffected by the exposure. Reproduction of grey pine aphids, *Schizolachnus pineti*, was not significantly affected by ozone exposure. Jøndrup et al. (2002) reported that the susceptibility to ozone of the plant, *Brassica rapa*, interacted with ozone-induced biochemical changes that affected its suitability for a specialized herbivore, *Pieris brassicae*. However, pollutants may interfere with olfactory detection of hosts. Gate et al. (1995) exposed braconid parasitoids, *Asobara tabida* to ozone, sulfur dioxide, and nitrogen dioxide in chambers with aggregations of its host, *Drosophila subobscura*. Ozone, but not sulfur dioxide or nitrogen dioxide, significantly reduced searching efficiency and the proportion of hosts that were parasitized. Parasitoids were able to avoid patches with no hosts, but appeared to be less able to distinguish different host densities, indicating that air pollutants could reduce the effect of predation or parasitism. Petrochemical contamination in streams may have little direct effect on aquatic organisms, but can cause oxygen depletion and increased CO<sub>2</sub> concentration, leading to changes in aquatic invertebrate composition and eventual elimination of all fauna (Couceiro et al. 2007, Harrel 1985).

Soil and water pH affects a variety of chemical reactions, including enzyme activity. Changes in pH resulting from acidification (such as from volcanic or anthropogenic activity) affect osmotic exchange, gill and spiracular surfaces, and digestive processes. Changes in pH often are correlated with other chemical changes, such as increased N or S, and the effects may be difficult to separate from these other factors. Pinder and Morley (1995) reported that many chironomid species are relatively tolerant of alkaline water, but few are tolerant of pH < 6.3. Other aquatic species may also be unable to survive in water of low pH (Batzer and Wissinger 1996). Acid deposition and loss of pH buffering capacity are likely to affect survival and reproduction of aquatic and soil/litter arthropods (Curry 1994, Pinder and Morley 1995).

#### D. Other Abiotic Factors

Many aquatic insects are sensitive to water level and flow rate (Ward 1992). These factors can fluctuate dramatically, especially in seasonal habitats, such as desert playas, intermittent streams, wetlands, and perched pools in treeholes and bromeliads (phytotelmata). Water level affects both the temperature and quality of the water; temperature because smaller volumes absorb or lose heat more quickly than do larger volumes, and quality because various solutes become more concentrated as water evaporates. Insects, and other





**FIG. 2.12** Relationship between sibling species composition of black flies (*Simulium truncatum*, solid line, *Simulium verecundum* AA, dashed line, and *Simulium venustum* CC2, dotted line) and distance from lake outlets on the Avalon Peninsula, Newfoundland, in early June. Least squares regression equations were significant at  $P < 0.01$ ; adjusted  $R^2$  values were 92%, 85% and 68 % for the three species, respectively. From P. Adler and McCreadie (1997) by permission from the Entomological Society of America.

aquatic arthropods, show life history adaptations to seasonal patterns of water availability or quality, often undergoing physiological diapause as water resources disappear (Batzer and Wissinger 1996, Ward 1992). Although most mosquitoes oviposit in surface water, floodwater mosquitoes, *Aedes* spp. and *Psorophora* spp., oviposit in soil at the high water line. Their eggs are resistant to desiccation and can remain dormant for several years. Egg hatch is stimulated by flooding, and the number of generations at a site depends on the frequency of flooding (Wiggins et al. 1980). Flow rate affects temperature and oxygenation, with cooler temperature and higher oxygen content at higher flow rates, but high flow rates can physically dislodge and remove exposed insects. McCreadie and Colbo (1993) and P. Adler and McCreadie (1997) reported that sibling species of black flies, *Simulium*, select different stream microhabitats on the basis of their adaptations to water velocity (Fig. 2.12).

Light is an important factor affecting development, behavior and/or distribution of many insects. Some aquatic insects are negatively phototactic during most of their lives, but may move toward light under conditions of oxygen depletion (Ward 1992). Algal feeders are more likely to occur in illuminated portions of streams. Moonlight affects drift rates for species that disperse in stream currents and is a synchronizing agent for emergence of a number of aquatic species, especially nocturnal feeders, with different species emerging during different lunar phases (Ward 1992). A variety of insects are attracted to lights at night, an attribute that facilitates collection and measurement of diversity (see Chapter 9), and normal dispersal or foraging activities may be disrupted by artificial lights.

Insects are particularly sensitive to ultraviolet and polarized radiation. Kelly et al. (2003) demonstrated, using experimental filters, that aquatic insects in the Little Qualicum River on Vancouver Island showed differential sensitivities to UVA and UVB exposure. Caddisflies (Trichoptera), especially *Dicosmoecus* spp. (Limnephillidae), were the most

sensitive to UV exposure. Final abundances under photosynthetically active radiation (PAR) alone were 15 times higher than under PAR+UVA and 40 times higher than under PAR+UVA+UVB. Stoneflies (Plecoptera) were 51% more abundant under PAR than under UV exposure. In contrast, chironomids (Diptera) were more abundant in the UV treatments. Mazza et al. (2002) and Rousseaux et al. (2004) reported that feeding by herbivorous insects was higher on foliage exposed to lower levels of UVB radiation, perhaps mediated by effects of UVB radiation on plant defensive compounds (see Chapter 3). Aquatic insects often are deceived by horizontally-polarized light from dark-colored reflective surfaces, such as automobiles, asphalt roads and oil spills; they mistake these for the surfaces of aquatic habitats (Horváth et al. 2009, Kriska et al. 2006).

### III. FACTORS AFFECTING DISPERSAL BEHAVIOR

Insects have a considerable capacity to escape adverse conditions and to seek optimal conditions within temperature, moisture and chemical gradients across landscapes or watersheds. Dispersal, the movement of individuals away from their source, is an important adaptive behavior that minimizes the risk that an entire population will be destroyed by disturbance or resource depletion, maximizes the chance that some individuals will find and exploit new resources, and maximizes genetic heterogeneity (D. Johnson 2004, Schowalter 1985, Wellington 1980, see Chapter 5). Nevertheless, dispersal entails considerable risk and requires significant energy expenditure (Rankin and Burchsted 1992). Torres (1988) documented cases of exotic insects being introduced into Puerto Rico by hurricane winds, including a swarm of desert locusts blown across the Atlantic Ocean from Africa. Many insects (and other organisms) fail to find or reach suitable habitats.

Flight capacity contributes enormously to the ability of insects to disperse. Adult aquatic insects can disperse from an intermittent pond or stream before the water disappears and search for other bodies of water. Dispersal may be particularly important for distributing populations and minimizing risk in ecosystems characterized by frequent disturbances. A number of factors affect the probability of successful dispersal, i.e., arrival at suitable habitats, including life history strategy, crowding, nutritional status, habitat and resource conditions, and the mechanism of dispersal.

#### A. Life History Strategy

The degree of adaptation to disturbance affects the predisposition of individuals to disperse. The species that characterize relatively stable, infrequently disturbed habitats tend to disperse slowly, i.e., produce few offspring and move short distances (see Chapter 5). Infrequent disturbance and consistent resource availability provide little or no selection for greater dispersal ability. Many forest species (especially Lepidoptera and Coleoptera) are flightless, or at least poor fliers. By contrast, species (such as aphids) that characterize temporary, frequently disturbed, habitats produce large numbers of individuals and a high proportion of dispersers. Such traits are important adaptations for species exploiting temporary, unstable, conditions (Janzen 1977).

#### B. Crowding

Crowding affects insect tendency to disperse, and in some cases may stimulate morphological or physiological transformations that facilitate dispersal (Anstey et al. 2009). Survival

and fecundity are often density dependent, i.e., inversely related to population density. Therefore, dispersing individuals may achieve higher fitnesses than do non-dispersing individuals at high population densities (Price 1997). For example, some bark beetle species oviposit their full complement of eggs in one tree under low density conditions, but only a portion of their eggs in one tree under high density conditions, leaving that tree and depositing remaining eggs in other trees (T. Wagner et al. 1981). If all eggs were laid in the first tree under crowded conditions, the large number of offspring could deplete resources before completing development.

Under crowded conditions, some insects spend more time eating and less time resting (R. Chapman 1982). Crowding increases the incidence of cannibalism in many species (Fox 1975a, b), encouraging dispersal. In addition, crowding can induce morphological changes that promote dispersal. Uncrowded desert locusts tend to repel one another and feed quietly on clumps of vegetation, whereas crowded locusts are more active, attract one another and march en masse, spending little time on vegetation (Anstey et al. 2009, Matthews and Matthews 2010). Accompanying physiological changes in color, wing length, and ability to feed on a wider variety of plants facilitate migration and the chances of finding suitable resources.

### C. Nutritional Status

Nutritional status affects the endurance of dispersing insects. Populations of many insects show considerable variation in fat storage and vigor as a result of variation in food quality, and in the quantity and maternal partitioning of nutrient resources to progeny (T. Wagner et al. 1981, Wellington 1980). Many species exhibit obligatory flight distances that are determined by the amount of energy and nutrient reserves: dispersing individuals respond to external stimuli only after depleting these reserves to a threshold level. Hence, less vigorous individuals tend to colonize more proximal habitats, whereas more vigorous individuals fly greater distances and colonize more remote habitats. Because crowding and nutritional status have opposite effects on dispersal, the per capita accumulation of adequate energy reserves and the number of dispersing individuals should peak when resource quality and quantity are still sufficient to promote insect development and vigor.

### D. Habitat and Resource Conditions

The likelihood that an insect will find a suitable patch depends strongly on patch or resource size, ease of discovery and proximity to insect population sources. Larger or more conspicuous habitats or resources are more likely to be perceived by dispersing insects or to be intercepted by a given direction of flight (see Chapter 7). Larger habitat patches intersect a longer arc centered on a given starting point. Insects dispersing in any direction have a higher probability of contacting larger patches than they do smaller patches. Courtney (1985, 1986) reported that the pierid butterfly, *Anthocharis cardamines*, preferentially oviposited on the most conspicuous (in terms of flower size) host species, which were less suitable for larval development than were less conspicuous hosts. This behavior by the adults represented a trade-off between the prohibitive search time that was required to find the most suitable hosts and the reduced rate of larval survival on the most conspicuous hosts.

The probability of survival declines with distance, as a result of depletion of metabolic resources and protracted exposure to various mortality factors (Pope et al. 1980). Hence, more insects reach closer resources or sites. Sartwell and Stevens (1975) and Schowalter

et al. (1981b) reported that, under non-outbreak conditions, the probability of bark beetle, *Dendroctonus* spp., colonization of living pine trees declined with distance from currently attacked trees. Trees more than 6 m from currently colonized trees had negligible probability of colonization by sufficient numbers to successfully kill the tree. Under outbreak conditions, the effect of distance disappeared (Schowalter et al. 1981b). Similarly, He and Alfaro (1997) reported that, under non-outbreak conditions, colonization of white spruce by the white pine weevil, *Pissodes strobi*, depended on host condition and distance from trees colonized the previous year, but during outbreaks most trees were sufficiently near occupied trees to be colonized.

## E. Mechanism of Dispersal

The mechanism of dispersal strongly affects the probability that suitable resources can be found and colonized. Three general mechanisms can be identified: random, phoretic, and directed (see Matthews and Matthews 2010).

Random dispersal direction and path are typical of most small insects with little capacity to detect or orient toward environmental cues. Such insects are at the mercy of physical barriers, or wind or water currents, and their direction and path of movement are determined by obstacles and patterns of air or water movement. For example, first instar nymphs of a *Pemphigus* aphid that live on the roots of sea asters growing in salt marshes climb the plants and are set adrift on the rising tide. Sea breezes enhance movement, and successful nymphs are deposited at low tide on new mud banks where they must seek hosts (Kennedy 1975). Aquatic insect larvae often are carried downstream during floods. Hatching gypsy moth, *Lymantria dispar*, and other tussock moth larvae (Lymantriidae), scale insect crawlers, and spiders (as well as other arthropods), disperse by launching themselves into the airstream (e.g., Matthews and Matthews 2010, McClure 1990). Lymantriid females and scale insect adults have poor (if any) flight capacity. Wind-aided dispersal by larval Lepidoptera and spiders is facilitated by extrusion of silk strands, a practice known as “ballooning”. Western spruce budworm, *Choristoneura occidentalis*, adults aggregate in mating swarms above the forest canopy and are carried by wind currents to new areas (Wellington 1980).

The distance traveled by wind- or water-dispersed insects depends on several factors, including flow rate and insect size or mass. Jung and Croft (2001) measured falling speeds, relative to morphology and activity, of several wind-dispersed mite species. Heavier mites fell more rapidly than did lighter mites, as expected. However, anesthetized mites fell more rapidly than did active mites, indicating that mites can control buoyancy and landing to some extent.

The probability that at least some insects will arrive at suitable resources depends on the number of dispersing insects and the predictability of wind or water movement in the direction of new resources. Most individuals fail to colonize suitable sites, and many become part of the aerial or aquatic plankton that eventually “falls out” and becomes deposited in remote, unsuitable, locations. For example, J. Edwards and Sugg (1990) documented fallout deposition of many aerially-dispersed insect species on montane glaciers in western Washington.

Phoretic dispersal is a special case in which a flightless insect or other arthropod hitches a ride on another animal (Fig. 2.13). Phoresy is particularly common among wingless Hymenoptera and mites. For example, scelionid wasps ride on the backs of female grasshoppers, benefitting from both transport and the eventual opportunity to oviposit on the grasshopper’s eggs. Wingless Mallophaga attach themselves to hippoboscid flies that



**FIG. 2.13** Phoretic mesostigmatid mites on coxae of scarab beetle. Photo courtesy of A. Tishechkin.

parasitize the same bird hosts. Many species of mites attach themselves to dispersing adult insects that feed on the same dung or wood resources (Krantz and Mellott 1972, Stephen et al. 1993). Birds and mammals provide long-distance transport for hemlock woolly adelgid, *Adelges tsugae* (McClure 1990). The success of phoresy (as with wind or water-aided dispersal) depends on the predictability of host dispersal. However, in the case of phoresy, success is enhanced by the association of both the hitchhiker and its mobile (and perhaps cue-directed) host with the same resource.

Directed dispersal provides the highest probability of successful colonization and is observed in larger, stronger fliers that are capable of orienting toward suitable resources (see Chapter 3). Many wood-boring insects, such as wood wasps (Siricidae) and beetles (especially Buprestidae) are attracted to sources of smoke, infrared radiation or volatile tree chemicals emitted from burned or injured trees over distances of up to 50 km (W. Evans 1966, Gara et al. 1984, Matthews and Matthews 2010, R.G. Mitchell and Martin 1980, Raffa et al. 1993, S. Schütz et al. 1999, Wickman 1964). Attraction to suitable hosts often is significantly enhanced by mixing with pheromones emitted by early colonists (see Chapters 3 and 4). Visual, acoustic or magnetic cues also aid orientation (Matthews and Matthews 2010). For example, masking the silhouette of tree boles with white paint substantially reduced landing by southern pine beetles, *Dendroctonus frontalis* (Strom et al. 1999), *Ips* engraver beetles, and some bark beetle predators (Goyer et al. 2004) that were attracted to them.

Migration is an active mass movement of individuals that functions to displace entire populations. Migration always involves females, but not always males. Examples of migratory behavior in insects include locusts, monarch butterflies, *Danaus plexippus*, and

ladybird beetles. Locust, *S. gregaria* and *Locusta migratoria*, migration depends, at least in part, on wind patterns. Locust swarms remain compact, not because of directed flight, but because randomly oriented locusts reaching the swarm edge reorient toward the body of the swarm. Swarms are displaced downwind into equatorial areas where converging air masses rise, leading to precipitation and vegetation growth that are favorable to the locusts (Matthews and Matthews 2010). In this way, migration displaces the swarm from an area of crowding and insufficient food to an area with more abundant food resources. Monarch butterfly and ladybird beetle migration occurs seasonally and displaces large numbers to and from overwintering sites, Mexico for North American monarch butterflies and sheltered sites for ladybird beetles. Merlin et al. (2009) reported that a gene-controlled circadian clock in monarch antennae provides the internal timing mechanism for a time-compensated sun compass that allows the insects to correct their flight direction relative to the position of the sun as it moves across the sky during the day.

#### IV. RESPONSES TO ANTHROPOGENIC CHANGES

Insect responses to anthropogenic disturbances reflect the degree to which habitat conditions following anthropogenic disturbance are similar to those which follow natural disturbances, e.g., forest harvest may elicit responses similar to natural canopy opening disturbances (Buddle et al. 2006, Grimbacher and Stork 2009); vegetation conversion to crop production elicits insect responses to changes in density and appearance of early successional hosts (see Chapter 3); river impoundment may elicit responses similar to landslides that also alter drainage pattern. However, some anthropogenic disturbances are unique, particularly the introduction of novel chemical pollutants into the environment. For example, aquatic organisms historically have had minimal exposure to the variety of toxins introduced into aquatic systems through agricultural and industrial production. Oil spills and urban sewage in streams affect not only the aquatic fauna but also terrestrial fauna in seasonally flooded habitats (Couceiro et al. 2007). Fires and other natural disturbances do not generate large numbers of stumps with exposed surfaces and in-ground root systems. Paving previously vegetated surfaces in urban settings has created the most extreme changes in habitat conditions for organisms sensitive to high temperature and desiccation. Furthermore, anthropogenic changes in climate and land use appear to be increasing the frequency of extreme weather events (Bender et al. 2010, Hossain et al. 2009, Kishtawal et al. 2010), which likely will affect species survival more than will changes in average conditions (Gutschick and BassiriRad 2010, Jentsch et al. 2007, Kaushal et al. 2010, Reusch et al. 2005).

The effects of such changes may be difficult to predict on the basis of adaptations to natural disturbances, and may persist for long periods, because local mechanisms are lacking for reversal of extreme alteration of vegetation, substrate, or water conditions. For example, Benstead et al. (2007) reported that the effects of low levels of nutrient enrichment to freshwater streams in the Arctic depended on the duration of enrichment as mediated by bryophyte colonization and subsequent physical disturbances that removed bryophytes. Harding et al. (1998) reported that responses of aquatic invertebrates to restoration treatments reflected differences in community structure among stream segments with different histories of anthropogenic disturbances. Similarly, Schowalter et al. (2003) found that litter arthropod responses to variable density thinning of conifer forests for restoration purposes reflected different initial community structures, resulting from previous thinning as much as 30 yrs earlier.

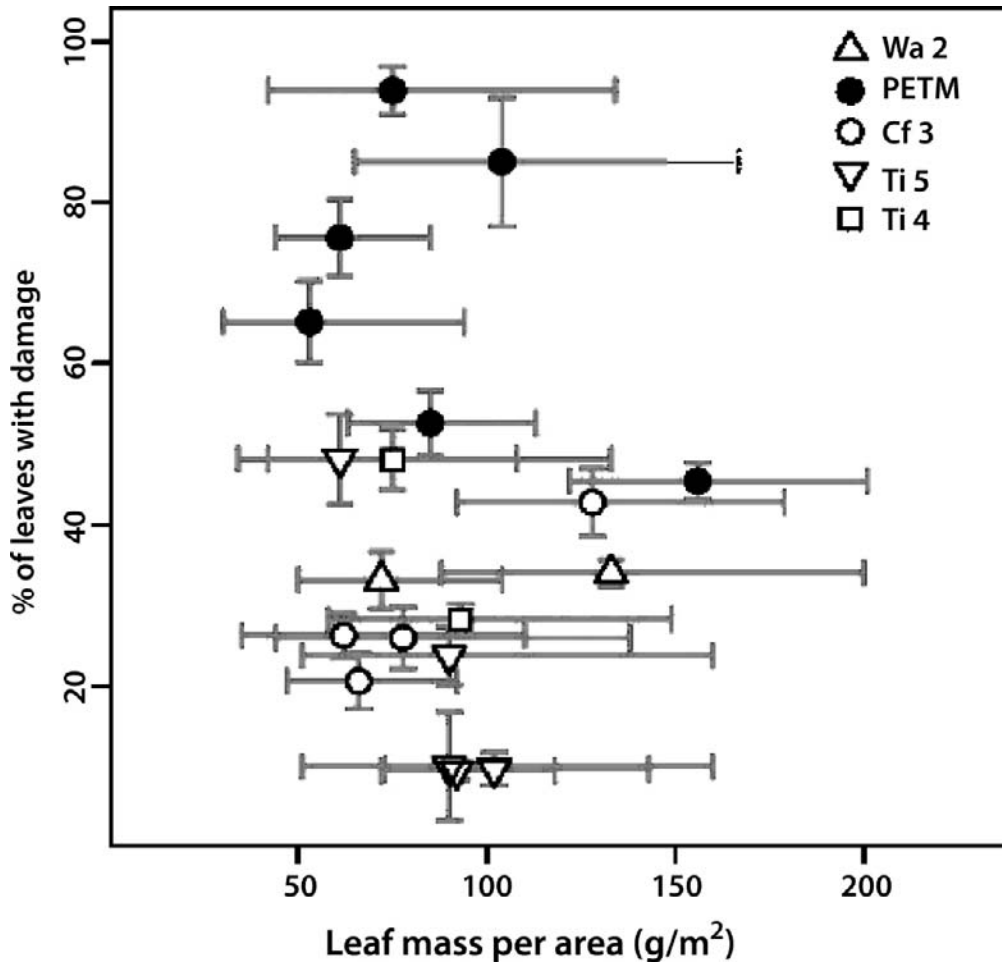
Detection of biotic responses to global climate change is complicated because effects of non-climatic, especially land use, factors tend to dominate local, short-term responses (Parmesan and Yohe 2003, Raffa et al. 2008). Parmesan and Yohe (2003) conducted a global meta-analysis for 1700 species. Results showed a 6.1 km/decade range shift toward the poles (or 6m/decade increase in elevation) and a 2.3 day/decade advance in spring events. This diagnostic pattern was found for 279 species (including plants, insects and vertebrates), indicating that climate change already is affecting ecosystems. Balanyá et al. (2006) reported that 22 populations of a cosmopolitan fly, *Drosophila subobscura*, on three continents had experienced the equivalent of a 1° change in latitude toward the Equator and showed a corresponding shift in genotypic composition equivalent to a 1° lower-latitude genotype. Bradshaw and Holzapfel (2001) and Mathias et al. (2007) found a detectable shift in genetically-controlled response of pitcherplant mosquitoes, *W. smithii*, to changing photoperiod as a result of warming temperatures.

A number of studies have documented insect responses to elevated temperature, increased atmospheric or aqueous concentrations of CO<sub>2</sub> or various pollutants, including pesticides, and habitat disturbance and fragmentation (e.g., Alstad et al. 1982, Arnone et al. 1994, Bezemer and Jones 1998, Heliövaara and Väisänen 1986, 1993, Kinney et al. 1997, Lincoln et al. 1993, Marks and Lincoln 1996, Valkama et al. 2007, Zavala et al. 2008). Although insect herbivores respond to a variety of factors, including photoperiod, relative humidity and host condition, that interact with effects of temperature (Bale et al. 2002), a number of studies suggest increased likelihood of herbivore outbreaks under future warming and/or drying scenarios (Breshears et al. 2005, J.A. Logan et al. 2003, Mattson and Haack 1987). Zavala et al. (2008) demonstrated that elevated atmospheric CO<sub>2</sub> compromised plant defense against herbivores by down-regulating gene expression for defensive compounds.

Paleontological data show increased herbivory during warming periods. Currano et al. (2008) reported that the frequency and diversity of leaf damage by herbivorous insects was significantly greater (mean 57%) during the Paleocene Eocene thermal maximum (PETM) 56 million years ago than during either the preceding Paleocene (<38%) or subsequent Eocene (33%) epochs (Fig. 2.14). Both the amount and diversity of herbivore damage on angiosperm leaves were correlated positively with temperature change 55–59 million yrs ago. As described above, the indirect effects of these changes may be greater than the direct effects.

Climate change may disrupt synchrony between herbivores and host plants or between predator and prey populations when interacting species' phenologies do not respond equally to changing temperature (Bale et al. 2002, Hance et al. 2007, A.F. Hunter and Elkinton 2000, Klapwijk et al. 2010, R. Lawrence et al. 1997, J.D. Logan et al. 2006, Visser and Both 2005, Visser and Holleman 2001, Watt and McFarlane 2002). For example, R. Lawrence et al. (1997) and A.F. Hunter and Elkinton (2000) found that cohorts of lepidopteran larvae placed on foliage at increasing time before or after budbreak showed reduced survival and increased development times, relative to larvae placed on foliage near the time of budbreak. A.F. Hunter and Elkinton (2000) found that predation had the opposite effect, indicating that disruption of phenological synchrony of budbreak, herbivore egg hatch and predation as a result of climate change could greatly affect herbivore population dynamics.

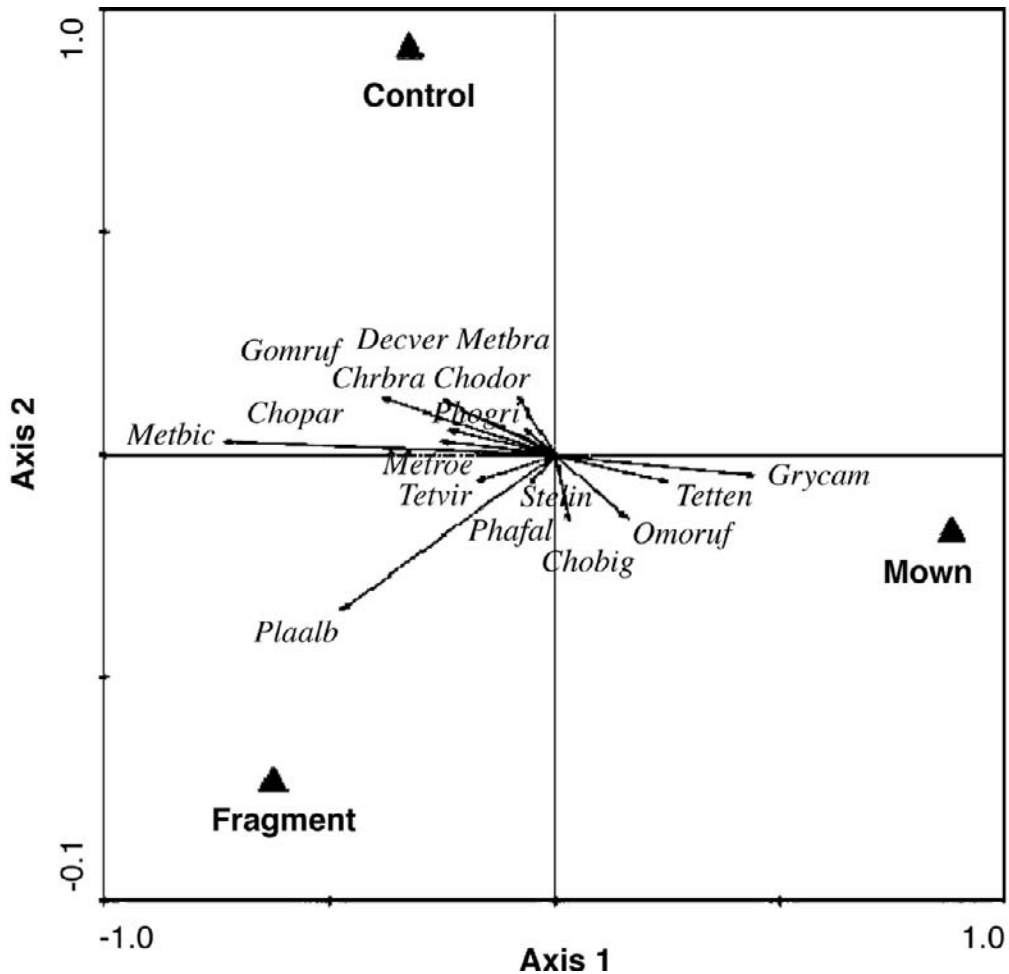
Changing land use patterns and ecosystem fragmentation alter abiotic variables and have the most dramatic effects on survival or movement of various insects (e.g., J. Chen et al. 1995, Franklin et al. 1992, Raffa et al. 2008, Roland 1993, Rubenstein 1992).



**FIG. 2.14** Estimated leaf mass per area (LMA) and damage frequency for individual plant species from sites representing time periods before (Tiffanian 4a and 5b [Ti 4 and 5, 57.5–58.9 Mya] and Clarkforkian 3 [Cf 3, 55.9 Mya]), during (PETM, 55.8 Mya), and after (Wasatchian 2 [Wa 2, 55.2 Mya]) the Paleocene–Eocene Thermal Maximum (PETM). LMA values are species means, and error bars represent 95% confidence intervals. Error bars for herbivory represent 1 standard deviation, based on a binomial sampling distribution. From Currano et al. (2008) by permission from the National Academy of Sciences, U.S.

Braschler et al. (2009) found that many orthopterans avoided the mown matrix in a fragmented grassland, probably because of the lack of shelter (Fig. 2.15). Consequently, small populations became increasingly isolated in remnant patches of grassland, increasing their vulnerability to local extinction if large areas are mown simultaneously. Kimberling et al. (2001) reported that physical disturbance related to construction or waste disposal had relatively less effect on invertebrate communities than did conversion of shrub-steppe to agricultural use in eastern Washington U.S. Nessimian et al. (2008) found that aquatic insect assemblages in central Amazonia differed significantly between streams passing through forest vs. pasture, but not among streams passing through primary forest, forest fragments or secondary forests. Altered drainage patterns affect temperature and





**FIG. 2.15** Redundancy analysis (RDA) biplot showing the effect of treatment (control, mown, and fragmented grassland plots) on orthopteran species composition. Most of the species were most abundant in the undisturbed plots, with the exception of *Gryllus campestris*, *Tetrix tenuicornis*, and *Omocestus rufipes*, which were more abundant in mown plots and *Platycleis albopunctata*, which was more abundant in the isolated fragments of undisturbed grassland. From Braschler et al. (2009) by permission from the authors and John Wiley & Sons.

chemical conditions of aquatic ecosystems and opportunities for organisms to disperse upstream or downstream (Pringle et al. 2000).

Pollution and invasive species are the most immediate threats to many species and ecosystems. Pollutants immediately threaten the survival of species at all trophic levels (e.g., Alstad et al. 1982, Trumble and Jensen 2004), thereby threatening food web interactions and ecosystem processes (Butler and Trumble 2008, Butler et al. 2009). For example, Trumble and Jensen (2004) reported that concentrations of 500–1000  $\mu\text{g g}^{-1}$  of hexavalent Cr (within the range of environmental contamination) in a diet fed to a terrestrial dipteran detritivore, *Megaselia scalaris*, increased development time by 65–100% and reduced survival by 50–94%. Because females did not discriminate among substrates

of varying Cr levels, populations are not likely to persist in contaminated areas, thereby reducing rates of decomposition and nutrient flux.

Invasive species can be considered to be biotic pollution because of their dramatic effects on native species and ecosystems. Invasive species often are favored by habitat disturbance. Once established, they can alter abundances and interactions among other species in the same way as abiotic pollutants. For example, invasive red imported fire ants, *Solenopsis invicta*, are most abundant in disturbed habitats (Stiles and Jones 1998, Zettler et al. 2004). Where abundant, they displace native ants, and negatively affect many ground nesting birds, small mammals and herpetofauna, through aggressive foraging behavior, high reproductive rates and lack of predators (C. Allen et al. 2004, S. Porter and Savignano 1990, Zettler et al. 2004). A. Suarez et al. (2001) found that habitat fragmentation also favored the invasive Argentine ant, *Linepithema humile*, at the expense of native ant species. Rare species may be disproportionately affected by habitat fragmentation (Summerville and Crist 2001).

Human use of ecosystem resources also changes conditions for insects. Andresen and Laurance (2007) found that hunting of forest mammals in Panama reduced mammal abundances and the availability of fecal resources for dung beetles, hence reducing dung beetle abundance and species composition. Diversion of streams for irrigation purposes alters water level, flow rate and temperature, changing habitat conditions for aquatic insects and altering community structure (S. Miller et al. 2007). Bredenhand and Samways (2009) reported that a single dam on the Eerste River in the Cape Floristic Region of South Africa altered the composition and abundance of aquatic macroinvertebrates. Species diversity below the dam was only half that in the pristine section above it. Diversity and abundance of Ephemeroptera, Plecoptera, Trichoptera (excluding Hydropsychidae) and Coleoptera below the dam were 30%, 1%, 25% and 6%, respectively, of their values above the dam, but Hydropsychidae were 15 times more abundant below the dam, largely reflecting differences in riparian vegetation and stream conditions. Excavation of shallow pits during brickmaking in sub-Saharan Africa increased the predator-free habitat for, and larval abundance of, *Anopheles gambiae*, the primary vector of malaria in the region (Carlson et al. 2009). Predator diversity in these pools increased with time since disturbance and was a major factor in ultimately reducing *A. gambiae* larval populations.

However, humans are changing environmental conditions in many ways simultaneously, through fossil fuel combustion, industrial effluents, water impoundment and diversion, pesticide application and land use practices. Large areas have been planted to genetically modified crops or occupied by invasive exotic species. Global atmospheric concentrations of CO<sub>2</sub> and other greenhouse gases are clearly increasing, and global climate has shown a distinct warming trend (e.g., Beedlow et al. 2004, Keeling et al. 1995). Acidic precipitation has greatly reduced the pH of many aquatic ecosystems in northern temperate countries. Nitrogen subsidies resulting from increased atmospheric NO<sub>x</sub> may provide a short-term fertilization effect in N-limited ecosystems, until pH buffering capacity of the soil is depleted. Deforestation, desertification, and other changes in regional landscapes are fragmenting habitats and altering habitat suitability for organisms around the globe. Mining activities and industrial effluents add highly toxic minerals to terrestrial and aquatic ecosystems.

The interactions among environmental factors are poorly understood, but often synergistic. For example, land use changes alter surface albedo and can exacerbate regional warming and storm intensity (Foley et al. 2003b, Hossain et al. 2009, T. Lewis 1998). Furthermore, studies in the Amazon basin indicate that smoke from fires that accompany

forest conversion to agricultural or urban land use reduce cloud cover (from 38% in clean air to 0% in heavy smoke), reduce droplet size, and increase the altitude at which water condenses, leading to more violent thunderstorms and hail, rather than warm rain (A. Ackerman et al. 2000, Andreae et al. 2004, Koren et al. 2004). Impounded reservoirs, along with associated land use changes (such as irrigated agriculture), alter surface fluxes of heat and moisture and potentially increase the frequency and intensity of precipitation (Hossain et al. 2009). The increased frequency of such extreme events may have greater effects on species survival than will overall trends (Gutschick and BassiriRad 2010).

Few studies have measured insect responses to multiple changes in ecosystem conditions. However, given insect sensitivity to environmental changes, as described above, any change will alter insect abundance and distribution and may increase the incidence of crop pests and vectors of human and animal diseases (Stapp et al. 2004, Summerville and Crist 2001, Vittor et al. 2006, D. Williams and Liebhold 2002, J. Zhou et al. 2002). Chapin et al. (1987) addressed plant responses to multiple stressors and concluded that multiple factors can have additive or synergistic effects, which can alter plant biochemistry and vulnerability to herbivores. Valkama et al. (2007) conducted a meta-analysis of experiments on effects of CO<sub>2</sub> and O<sub>3</sub> on insect-plant interactions. They found that elevated O<sub>3</sub> tended to reduce foliage quality, but also improved indices of insect performance, whereas elevated CO<sub>2</sub> counteracted this effect. Warren et al. (2001) evaluated changes, over the past 30 yrs, in distribution and abundances of 46 butterfly species that approach their northern range limits in Great Britain. Most species (75%) declined in distribution and abundance, indicating that negative responses to habitat loss outweighed positive responses to climate warming in the region. S. Richardson et al. (2002) simulated temperature and nutrient changes in a sub-Arctic dwarf shrub-heath ecosystem and found that most insect responses were related to increased grass abundance in warmed and fertilized plots. Song and Brown (2006) reported that the estuarine mosquito, *Aedes taeniorhynchus*, was more tolerant of pesticide exposure during periods of changing salinity, and was more tolerant during decreasing salinity than during increasing salinity.

We should expect some insects to disappear as habitat conditions exceed their tolerance ranges or their hosts disappear. Others will become more abundant and may facilitate host plant decline by exploiting stressed and poorly defended hosts (see Chapter 3). Insect responses to environmental changes affect human activity and health, as well as sustainability of ecosystem services (see Chapter 16). For example, Vittor et al. (2006) described increased biting rate of mosquitoes, *Anopheles darlingi*, responsible for transmission of malaria to humans, associated with deforestation and road development in Peru (see box introducing this chapter). Clearly, more studies are needed on insect responses to multiple natural and anthropogenic changes in order to improve prediction of effects of environmental changes.

## V. SUMMARY

Insects are affected by abiotic conditions that reflect latitudinal gradients in temperature and moisture, as modified by circulation patterns and mountain ranges. At the global scale, latitudinal patterns of temperature and precipitation produce bands of tropical rainforests along the equatorial convergence zone (where warming air rises and condenses moisture), deserts centered at 30°N and S latitudes (where cooled, dried air descends), and moist boreal forests centered at 60°N and S latitudes (where converging air masses rise

and condense moisture). Mountains affect the movement of air masses across continents, forcing air to rise and condense on the windward side, and dried air to descend on the leeward side. The combination of mountain ranges and latitudinal gradients in climatic conditions creates a template of regional ecosystem types known as biomes, characterized by distinctive vegetation types (e.g., tundra, desert, grassland, forest). Aquatic biomes are distinguished by size, depth, flow rate and marine influence (e.g., ponds, lakes, streams, rivers, estuaries).

Environmental conditions are not static but vary seasonally and annually. In addition, environment conditions change over longer periods as a result of global processes and anthropogenic activities. Acute events (disturbances), such as storm or fire, can dramatically alter habitat conditions and resource availability for various organisms. Hence, insects must be able to avoid or adjust to changing conditions.

The inherent problems of maintaining body heat and water content and avoiding adverse chemical conditions by small, heterothermic organisms has led to an astounding variety of physiological and behavioral mechanisms by which insects adjust to and interact with environmental conditions. Recent research on genetic control of physiological processes is improving our understanding of the mechanisms of adaptation. Mechanisms for tolerating or mitigating the effects of variation in abiotic factors determine the seasonal, latitudinal and elevational distributions of insect species.

Many insects have a largely unappreciated physiological capacity to cope with the extreme temperatures and relative humidities found in the harshest ecosystems on the planet. However, even insects in more favorable environments must cope with variation in abiotic conditions through diapause, color change, evaporative cooling, supercooling, voiding of the gut, control of respiratory water loss, etc. Many species exhibit at least limited homeostatic ability, i.e., the ability to regulate their internal temperature and water content.

Behavior represents the active means by which animals respond to their environment. Insects are sensitive to a variety of environmental cues, and most insects are able to modify their behavior in response to environmental gradients or changes. Insects, especially those that can fly, move within gradients of temperature, moisture, chemicals or other abiotic factors to escape adverse conditions. Many species are able to regulate their body heat or water content by rapid muscle contraction, elevating the body above hot surfaces, seeking shade, or burrowing. Social insects appear to be particularly flexible in the use of colony activity and nest construction to facilitate thermoregulation.

Many insects are capable of flying long distances, but dispersal entails considerable risk, and many individuals do not reach suitable habitats. The probability that an insect will discover a suitable patch is a function of the tendency to disperse (as affected by life history strategy and crowding), endurance (determined by nutritional condition), patch size, distance, and the mechanism of dispersal (whether random, phoretic or directed toward specific habitat cues).

Environmental changes resulting from anthropogenic activities are occurring at an unprecedented rate. A number of studies have demonstrated significant effects of anthropogenic changes on the abundances of various insects and indicate that global changes could increase the incidence of herbivore outbreaks. However, few studies have addressed the effects of multiple interacting changes on insects.

This page intentionally left blank

# Resource Acquisition

## I. Resource Quality

- A. Resource Requirements
- B. Variation in Food Quality
- C. Plant Chemical Defenses
- D. Arthropod Defenses
- E. Variation in Resource Quality
- F. Mechanisms for Exploiting Variable Resource Quality

## II. Resource Acceptability

## III. Resource Availability

- A. Discovering Suitable Resources
- B. Orientation
- C. Learning

## IV. Summary

### Advances in understanding biochemical interactions between plants and insects

Biochemical interaction between insects and plants has been a cornerstone of insect ecology, providing critical data on the mechanisms of evolution, and applications for pest management, and integrating species interactions with biogeochemical cycling. Important groundwork for this topic had been laid by 1900; plant pharmaceutical properties were recognized at least 2500 years ago (Farnsworth 1966, Hamilton and Baskett 2000, Millspaugh 1892), plant variation in susceptibility to insect herbivores by the late 1700s (C. Smith 2005, Sorensen et al. 2008), and insecticidal properties of some plant products, such as the powdered flower heads of *Pyrethrum roseum*, by 1800 (C. Riley 1885).

Conceptual synthesis began when R. Painter (1951) recognized that plant resistance to insects could be expressed through antibiosis, anti-xenosis and tolerance. Fraenkel (1953) subsequently noted that, since plant species show relatively little variation in nutritional value, resistance to insects must reside in their “secondary metabolites”. However, major advances in analytical technology (e.g., GC-MS equipment) during the 1960s, coupled with conceptual stimulus and serendipity, spurred progress in understanding the chemical mechanisms of insect-plant interactions.

Hairston et al. (1960) stimulated research on plant defense by suggesting that plants had little role in regulating herbivore populations, which instead were regulated by predation. We soon learned that a variety of phytochemicals provide effective defense against herbivory (e.g., Feeny 1969, 1970, Rosenthal and Janzen 1979) and that herbivorous insects show specific adaptations

to avoid or detoxify plant defenses, supporting a view of an “evolutionary arms race” between plants and insects (Whittaker and Feeny 1971, but see Berenbaum and Zangerl 1988).

Serendipity played a role when Rhoades (1983) and I. Baldwin and Schultz (1983) independently found evidence, in environmental chambers, that plants that had been damaged by herbivorous insects communicated this information to neighboring undamaged plants, which initiated production of anti-herbivore defenses in advance of herbivory. Although their hypothesis that plants communicate the threat of herbivory (popularly termed the “talking tree” hypothesis) was challenged because of apparent lack of an evolutionary mechanism (e.g., Fowler and Lawton 1985), additional research confirmed that volatile elicitors induce defenses in a wide variety of plants, even species unrelated to the signaller (Farmer and Ryan 1990, M. Stout et al. 2006), and that these plant volatiles also attract predators (Bruinsma and Dicke 2008, Turlings et al. 1990).

Recent advances in molecular technology have demonstrated genetic mechanisms governing these interactions, typically involving P-450 genes (Berenbaum and Zangerl 2008, Y. Mao et al. 2007). Insertion of genes for bacterial toxins into crop genomes has permitted measurement of rates at which herbivorous insects adapt, and which insect genes are targets for selection (F. Huang et al. 2007).

However, production of defenses by a plant requires energy and nutrients (especially nitrogen), and affects litter quality and the return of nutrients to soil (Holopainen et al. 1995, Schweitzer et al. 2005, Whitham et al. 2006), thereby linking insect–plant interactions to energy flow, biogeochemical cycling and disturbance regime at the ecosystem level (see Chapters 11 and 12). The contemporary view of insect–plant interaction recognizes a variety of mechanisms and trade-offs that will continue to generate new insights into evolutionary and ecosystem theory.

## INTRODUCTION

ALL ORGANISMS ARE EXAMPLES OF NEGATIVE ENTROPY, IN CONTRAST to the tendency for energy to be dissipated, according to the Second Law of Thermodynamics. Organisms acquire energy in order to collect resources and synthesize the organic molecules that are the basis for life processes, growth and reproduction. Hence, the acquisition and concentration of energy and matter are necessary goals of all organisms and largely determine individual fitness.

Insects, like other animals, are heterotrophic, i.e., they must acquire their energy and material resources from other organisms (see Chapter 11). As a group, insects exploit a wide range of resources, including plant, animal and detrital material, but individual organisms must find and acquire more specific resources to support their growth, maintenance and reproduction.

The organic resources used by insects vary widely in quality (nutritional value), acceptability (preference ranking, given choices and trade-offs) and availability (density and ease of detection by insects), depending on environmental conditions. Physiological and behavioral mechanisms for evaluating and acquiring food resources, and their efficiencies under different developmental and environmental conditions, are the focus of this chapter.

## I. RESOURCE QUALITY

Resource quality is the net energy and nutrient value of food resources after deducting the energetic and nutrient costs required for the digestion and assimilation of the resource. The energy and nutrient value of organic molecules is a product of the number, elemental

composition and bonding energy of its constituent atoms. However, organic resources are not equally digestible into useable components. Some resources provide little nutritional value for the expense of acquiring and digesting them, others cannot be digested by common enzymes, and many organic molecules are essentially unavailable, or even toxic, to a majority of organisms. Some organic molecules are cleaved into toxic components by commonly-occurring digestive enzymes. Therefore, acquiring sufficient amounts of suitable resources is a challenge for all animals.

## A. Resource Requirements

Dietary requirements for all insects include carbohydrates, amino acids, cholesterol, B vitamins and inorganic nutrients, such as P, K, Ca, Na, etc. (Behmer 2009, R. Chapman 2003, Rodriguez 1972, Sterner and Elser 2002). Insects lack the ability to produce their own cellulases to digest cellulose. Nutritional value of plant material often is limited further by deficiency in certain requirements, such as low content of N (Mattson 1980), Na (Seastedt and Crossley 1981b, Smedley and Eisner 1995), or linoleic acid (Fraenkel and Blewett 1946). Resources differ in balance among essential nutrients, resulting in relative limitation of some nutrients and potentially toxic levels of others (Behmer 2009, Sterner and Elser 2002). High lignin content toughens foliage and other plant tissues, and limits feeding by herbivores without reinforced mandibles. Toxins or feeding deterrents in food resources increase the cost, in terms of search time, energy and nutrients, necessary to exploit nutritional value.

For individual insects, several factors influence food requirements. The most important of these are the size and maturity of the insect and the quality (nutritional balance) of food resources. Larger organisms require more food and consume more oxygen per unit time than do smaller organisms, although the latter consume more food and oxygen per unit biomass (Reichle 1968). Insects require more food, but often are able to digest a wider variety of resources, as they mature. Holometabolous species must store sufficient resources during larval feeding to support pupal diapause and adult development and, for some species, to support dispersal and reproduction by non-feeding adult stages.

## B. Variation in Food Quality

Food quality varies widely among resource types. The form that plant growth takes can determine its suitability as food for some insects. For example, Espirito-Santo et al. (2007) reported that plant architecture determines the distribution of suitable sites for gall formation. Plant material has a relatively low nutritional quality, since nitrogen typically occurs at low concentrations, and most plant material is composed of excess amounts of carbohydrates, often in the form of indigestible cellulose and lignin, relative to protein. Woody tissues are particularly low in labile resources that are readily available to insects, or to other animals. Plant detrital resources may be impoverished in important nutrients as a result of weathering, leaching, or plant resorption prior to shedding senescent tissues (Marschner 1995).

Individual plants differ in their resource quality for a number of reasons, including soil fertility. Low nitrogen levels in plants often limit insect herbivore growth and reproduction. Ohmart et al. (1985) reported that *Eucalyptus blakelyi* subjected to different N fertilization levels significantly affected fecundity of *Paropsis atomaria*, a chrysomelid beetle. An increase in foliar N from 1.5% to 4.0% increased the number of eggs laid by 500%



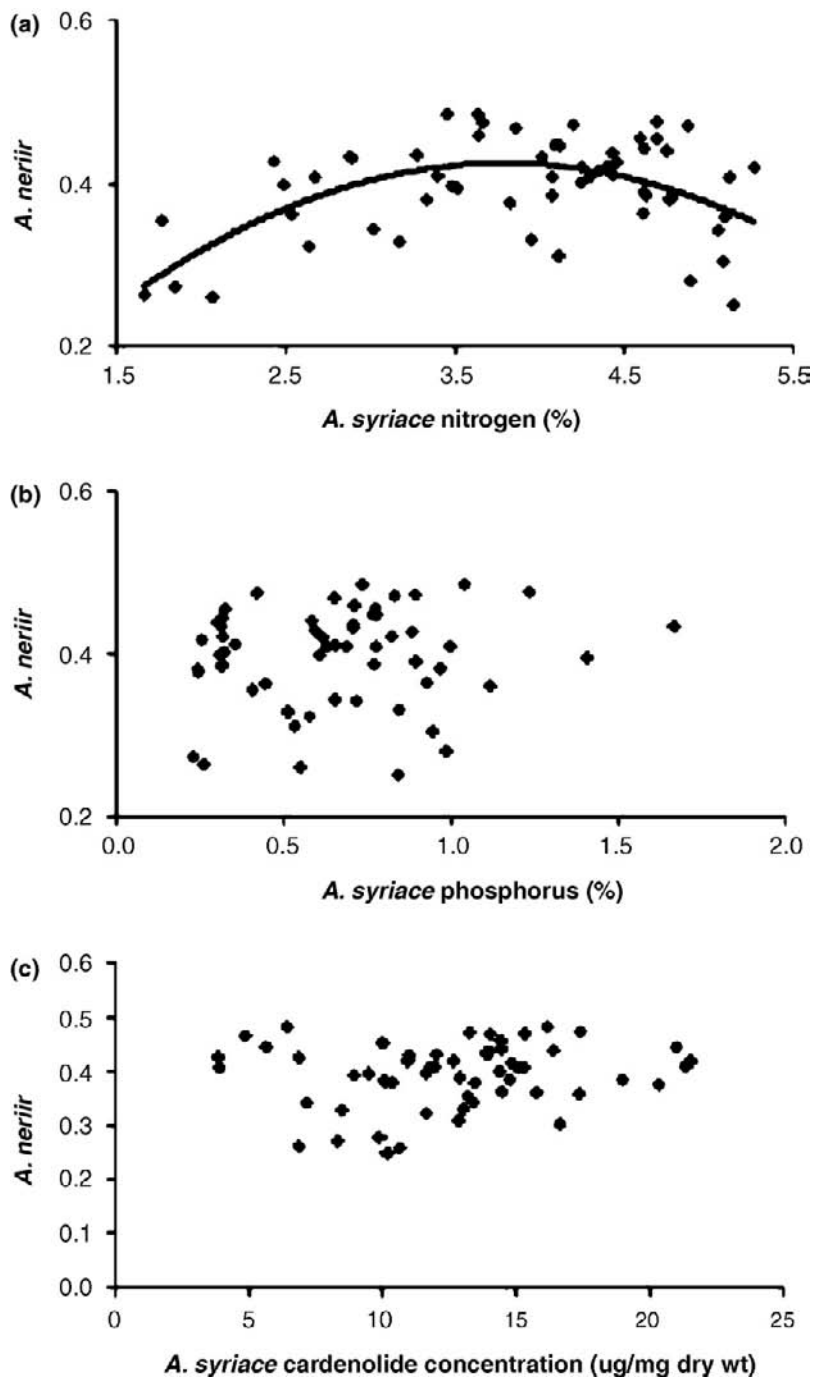
and the rate of egg production by 400%. Similarly, Blumberg et al. (1997) reported that arthropod abundances were higher in plots receiving inorganic N (granular ammonium nitrate, rye grass cover crop) than in plots receiving organic N (crimson clover, *Trifolium incarnatum*, cover crop). However, increasing nitrogen in plant tissues does not necessarily improve herbivore performance. Zehnder and Hunter (2009) reported that *Aphis nerii* population growth on milkweed, *Asclepias syriaca*, peaked at intermediate levels of nitrogen addition (Fig. 3.1).

The nutritional value of plant resources often changes seasonally and ontogenically. Filip et al. (1995) reported that the foliage of many tropical trees has higher nitrogen and water content early in the wet season than late in the wet season. R. Lawrence et al. (1997) caged several cohorts of spruce budworm, *Choristoneura fumiferana*, larvae on white spruce at different phenological stages of the host. Cohorts that began feeding 3–4 weeks before budbreak, and completed larval development prior to the end of shoot elongation developed significantly faster, and showed significantly greater survival rate and adult mass, than did those cohorts that were caged later (Fig. 3.2). These results indicate that the phenological window of opportunity for this insect was sharply defined by the period of shoot elongation, during which foliar nitrogen, phosphorus, potassium, copper, sugars, and water were higher than in mature needles.

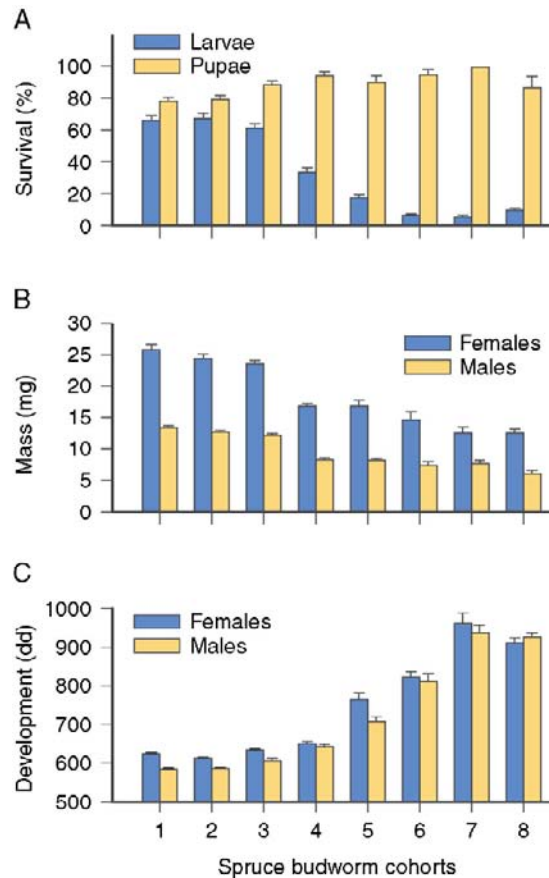
Food resources often are defended in ways that limit their utilization by consumers. Physical defenses include spines, toughened exterior layers, and other barriers. Spines and hairs can inhibit attachment or penetration by small insects, or can interfere with ingestion by larger organisms. These structures often are associated with glands that augment the defense by delivering toxins. Some plants entrap phytophagous insects in adhesives (R.W. Gibson and Pickett 1983). Toughened exteriors include the lignified epidermis of foliage and bark of woody plants, and the heavily armored exoskeletons of arthropods. Bark is a particularly effective barrier to penetration by most organisms (Ausmus 1977), but lignin also reduces the ability of many insects to utilize toughened foliage (e.g., Scriber and Slansky 1981). The viscous latex and oleoresin (pitch) produced by conifers and some hardwoods can push insects out of plant tissues (Fig. 3.3).

Many plant and animal species are protected indirectly through interactions with other organisms, especially non-host plants, ants or endophytic fungi (see Chapter 8). An otherwise suitable plant can be “hidden”, or made non-apparent, by unsuitable plants that mask its presence (e.g., Barbosa et al. 2009, Courtney 1985, 1986, M. Stanton 1983, Visser 1986). A number of plant species provide food sources (extrafloral nectaries) or habitable structures (domatia) to attract or house colonies of aggressive ants or predaceous mites (e.g., Brenes-Arguedas et al. 2008, R. Fischer et al. 2002, Huxley and Cutler 1991). Some plants emit chemical signals that attract parasitic wasps (Kessler and Baldwin 2001, Turlings et al. 1993, 1995). G. Carroll (1988), Clay et al. (1993), and D. Wilson and Faeth (2001) reported that foliar infection by endophytic fungi reduced herbivory by insects.

Both plants and insects produce a remarkable range of compounds that have been important sources of pharmaceutical or industrial compounds (see Chapter 16), as well as effective defenses. These “secondary plant compounds” function as toxins or feeding deterrents, and also may increase exposure and effect of predators and parasites (Lill and Marquis 2001). Biochemical interactions between herbivores and their host plants, and between predators and their prey, have been one of the most stimulating areas of ecological and evolutionary research since the 1960s. Major points affecting ecological processes are summarized below.



**FIG. 3.1** Relationship between per capita population growth rate ( $r$ ) of the aphid, *Aphis nerii*, and A) foliar nitrogen concentration, B) foliar phosphorus concentration, and C) foliar cardenolide concentration of its milkweed host, *Asclepias syriaca*. Each point represents a single aphid–host plant pair. From Zehnder and Hunter (2009) with permission from the authors and John Wiley & Sons.



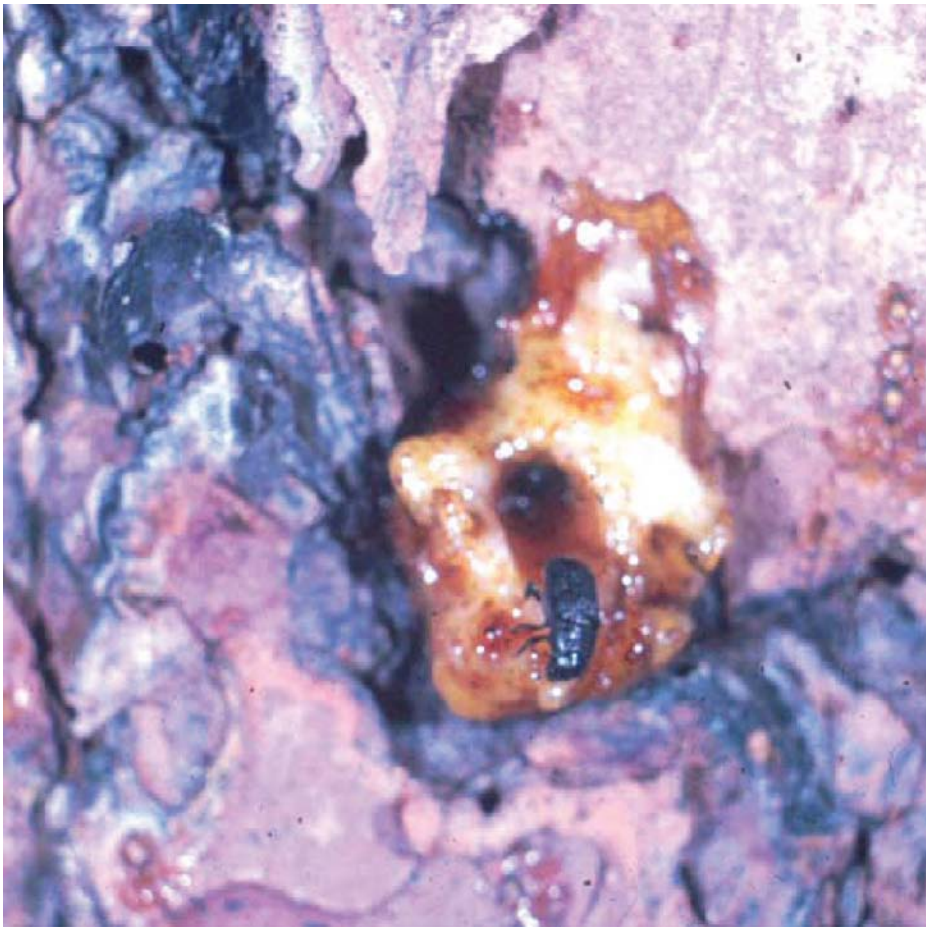
**FIG. 3.2** Larval and pupal survival (A), adult dry mass (B) and development time from 2<sup>nd</sup> instar through adult (C) for eight cohorts of spruce budworm caged on white spruce in 1985. The first six cohorts were started at weekly intervals beginning on Julian date 113 (April 23) for cohort 1. Cohort 7 started on Julian date 176 (June 25), and cohort 8 on Julian date 204 (July 23). Each cohort remained on the tree through completion of larval development, 6–7 wks. Budbreak occurred during Julian dates 118–136, and shoot elongation during Julian dates 118–170. From R. Lawrence et al. (1997) with permission from the Entomological Society of Canada.

## C. Plant Chemical Defenses

Plant chemical defenses are generally classified as non-nitrogenous, nitrogenous, and elemental. Nitrogenous and non-nitrogenous categories are represented by a wide variety of compounds, many differing only in the structure and composition of attached radicals. Elemental defenses are conferred by plant accumulation of toxic elements from the soil.

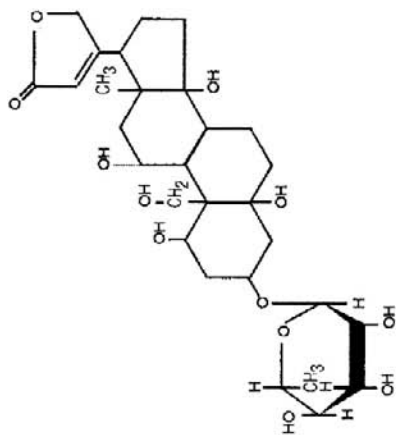
### 1. Non-Nitrogenous Defenses

Non-nitrogenous defenses include phenolics, terpenoids, photooxidants, insect hormone or pheromone analogs, pyrethroids, and aflatoxins (Figs. 3.3–3.6). Phenolics, or flavonoids, are distributed widely among terrestrial plants and are likely among the oldest plant secondary (i.e., non-metabolic) compounds. Although phenolics are perhaps best

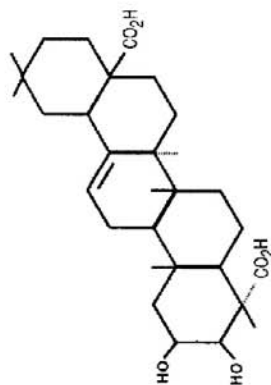


**FIG. 3.3** The wound response of conifers constitutes a physical–chemical defense against invasion by insects and pathogens. The oleoresin, or pitch, flowing from severed resin ducts hinders penetration of the bark.

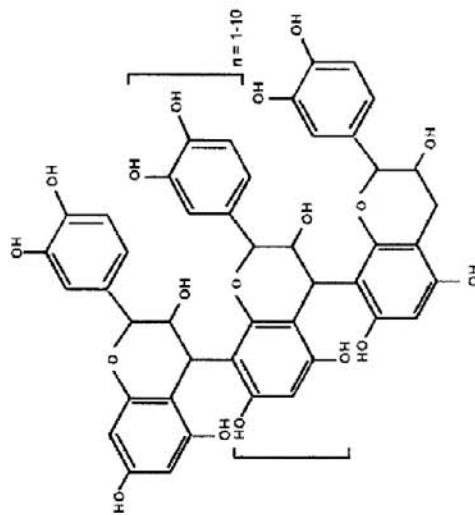
known as defenses against herbivores and plant pathogens, they also protect plants from damage by UV radiation, provide support for vascular plants (lignins), comprise pigments that determine flower color for angiosperms, and play a role in plant nutrient acquisition by affecting soil chemistry. Phenolics include the hydrolyzable tannins, derivatives of simple phenolic acids, and condensed tannins, polymers of higher molecular weight hydroxyflavonol units (Fig. 3.4). Polymerized tannins are highly resistant to decomposition, eventually making up the humic materials that largely determine soil properties. Tannins are distasteful, typically bitter and astringent, and act as feeding deterrents for many herbivores. When ingested, tannins can chelate nitrogen-bearing molecules to form indigestible complexes (Feeny 1969), but their primary toxic effect is through oxidation in the herbivore gut to form semiquinones and other highly oxidative compounds that damage cell membranes and DNA (Barbehenn et al. 2008). Insects incapable of catabolizing tannins or preventing chelation suffer gut damage and are unable to assimilate nitrogen from their food.



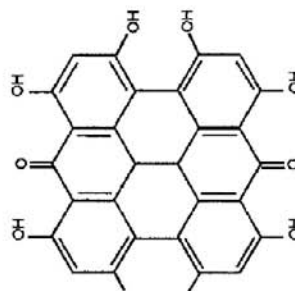
Terpenoid cardiac glycoside, ouabain, from *Acokanthera ouabaio*



Terpenoid saponin, medicagenic acid, from *Medicago sativa*



Flavanoid tannin, procyanidin, from *Quercus* spp.



Quinone, hypericin, from *Hypericum perforatum*

**FIG. 3.4** Examples of non-nitrogenous defenses of plants. From Harborne (1994).

Rhoades (1977) examined the effect of phenolic resins, primarily nordihydroquaiaretic acid, on the foliage surface of creosote bushes, *Larrea tridentata* from the southwestern U.S. and *Larrea cuneifolia* from Argentina. Young leaves contained about twice as much resin (26% d.w. for *L. tridentata*, 44% for *L. cuneifolia*) as did mature leaves (10% for *L. tridentata*, 15% for *L. cuneifolia*), but the amounts of nitrogen and water did not differ between leaves of different ages. Leaf-feeding insects that consume entire leaves all preferred the mature foliage. Extraction of resins from foliage increased feeding on both young and mature leaves by a generalist grasshopper, *Cibacris parviceps*, but reduced feeding on mature leaves by a specialist geometrid, *Semiothisa colorata*, in laboratory experiments, suggesting that low concentrations of resins may be a feeding stimulant for *S. colorata*.

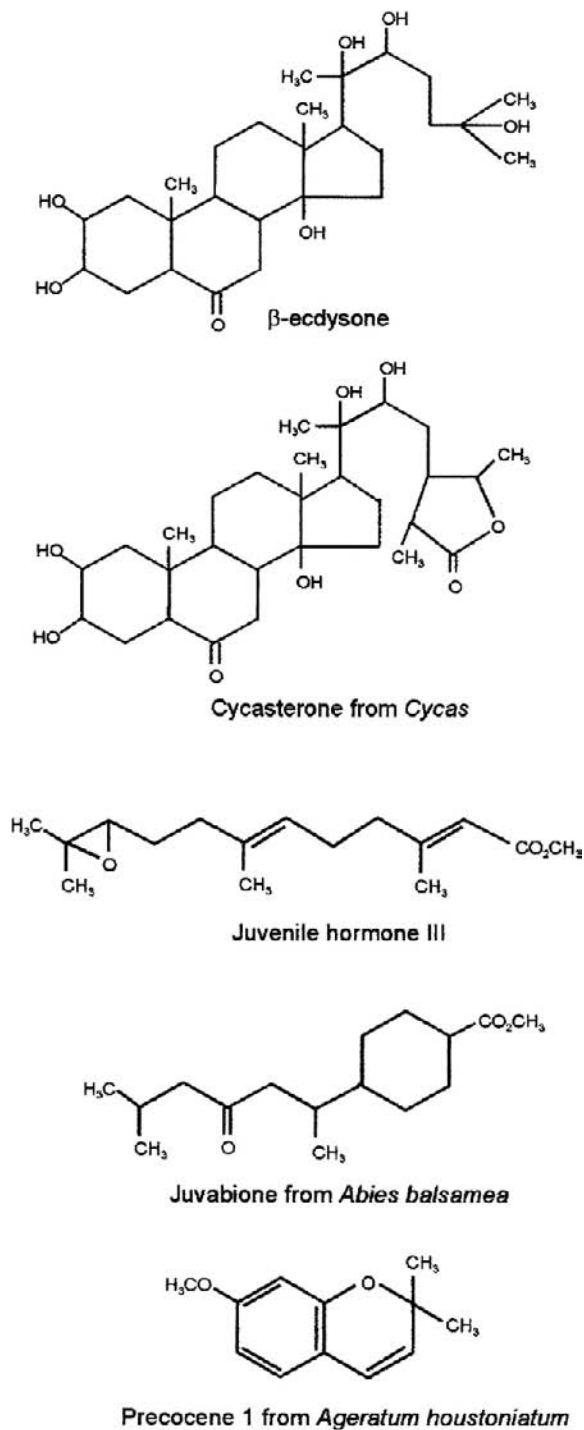
Terpenoids also are widely represented among plant groups. These compounds are synthesized by linking isoprene subunits. The lower molecular weight mono-terpenes and sesqui terpenes are highly volatile compounds that function as floral and foliar scents. They attract pollinators and herbivores, often along with associated predators and parasites, to their hosts, in addition to serving a defensive function. Some insects modify plant terpenes for use as pheromones (see Chapter 4). Terpenoids with higher molecular weights include plant resins, cardiac glycosides, saponins and latex (Figs. 3.3 and 3.4). Terpenoids typically are distasteful or toxic to herbivores. Latex or pitch flow is a general response to wounding, but can physically push insects away, adhere to their mouthparts and hence interfere with further feeding, and/or kill insects and associated microorganisms (Agrawal and Kono 2009, Nebeker et al. 1993). An advantage of this mode of defense is its accumulation at the site where the latex or resin canals are severed.

Becerra (1994) reported that the tropical succulent shrub, *Bursera schlechtendalii*, stores terpenes under pressure in a network of canals in its leaves and stems. When these canals are broken during insect feeding, the terpenes are squirted up to 150 cm, bathing the herbivore and drenching the leaf surface. A specialized chrysomelid, *Blepharida* sp., partially avoids this defense by severing leaf veins before feeding, but nevertheless suffers high mortality and may spend more time cutting veins than feeding, thereby suffering reduced growth.

Cardiac glycosides (cardenolides) are terpenoids best known as the milkweed (Asclepiadaceae) compounds sequestered by monarch butterflies, *Danaus plexippus*. Ingestion of these compounds by vertebrates either induces vomiting or results in cardiac arrest. The butterflies thereby gain protection against predation by birds (L. Brower et al. 1968). However, monarch caterpillars suffer high mortality on milkweed species, e.g., *Asclepias humistrata*, that have high concentrations of cardiac glycosides (Zalucki et al. 2001).

Photooxidants, such as quinones (Fig. 3.4) and furanocoumarins, increase epidermal sensitivity to solar radiation. Assimilation of these compounds results in severe sunburn, necrosis of the skin, and other epidermal damage upon exposure to sunlight. Feeding on furanocoumarin-producing plants in daylight can cause 100% mortality to insects, whereas feeding in the dark causes only 60% mortality (Harborne 1994). Adapted insects circumvent this defense by becoming leaf rollers or nocturnal feeders (Harborne 1994) or by sequestering antioxidants (Blum 1992).

Plants produce a variety of insect hormone analogues that disrupt insect development, typically preventing maturation or producing imperfect, sterile adults (Harborne 1994). Insect development is governed primarily by the molting (ecdysone) and juvenile hormones (Fig. 3.5). The relative concentrations of these two hormones dictate the timing of ecdysis and the subsequent stage of development. Some phytoecdysones are as much as 20 times more active than are ecdysones produced by insects and resist inactivation by insect enzymes (Harborne 1994). Schmelz et al. (2002) reported that spinach, *Spinacia oleracea*, produces 20-hydroxyecdysone



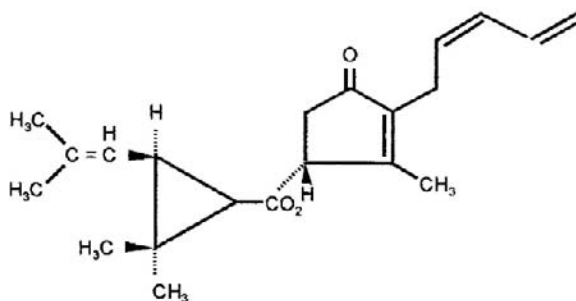
**FIG. 3.5** Insect developmental hormones and examples of their analogues in plants. From Harborne (1994).

in roots in response to root damage or root herbivory. Root feeding by a fly, *Bradysia impatiens*, increased production of 20-hydroxyecdysone by > 4-fold. Fly larvae preferred diets with low concentrations of 20-hydroxyecdysone and showed significantly reduced survival when reared on diets containing higher concentrations. Plants also produce juvenile hormone analogues (primarily juvabione), and compounds that interfere with juvenile hormone activity (primarily precocene, Fig. 3.5). The anti-juvenile hormones typically cause precocious development.

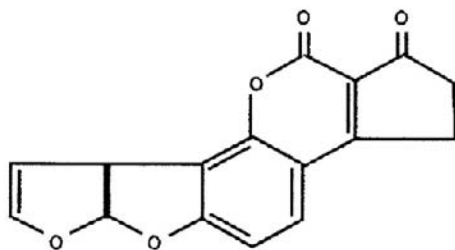
Some plants produce insect alarm pheromones that induce rapid departure of colonizing insects. For example, wild potato, *Solanum berthaultii*, produces (E)- $\beta$ -farnesene, the major component of alarm pheromones for many aphid species. This compound is released from glandular hairs on the foliage in sufficient quantities to induce avoidance by host-seeking aphids and departure of settled colonies (R. Gibson and Pickett 1983).

Pyrethroids (Fig. 3.6) are an important group of plant toxins, and among the earliest plant defenses to be recognized (C. Riley 1885). Many synthetic pyrethroids are widely used as contact insecticides, i.e., they are absorbed through the exoskeleton, because of their rapid effect on insect pests.

Aflatoxins (Fig. 3.6) are highly toxic fungal compounds. Aflatoxins produced by mutualistic endophytic or mycorrhizal fungi apparently augment defense by plant hosts (G. Carroll 1988, Clay 1990, Clay et al. 1985, 1993, Harborne 1994, van Bael et al. 2009). Endophytic and mycorrhizal fungi may also induce host plants to increase production of defensive compounds when injured by herbivores (Hartley and Gange 2009).



Pyrethrin I, from *Chrysanthemum cinerifolium*



Aflatoxin B, from *Aspergillus flavus*

**FIG. 3.6** Examples of pyrethroid and aflatoxin defenses. From Harborne (1994).



## 2. Nitrogenous Defenses

Nitrogenous defenses include non-protein amino acids, toxic proteins, cyanogenic glucosides, glucosinolates and alkaloids (Zenk and Juenger 2007). These compounds typically interfere with protein function or physiological processes.

Non-protein amino acids are analogues of essential amino acids (Fig. 3.7). Their substitution for essential amino acids in proteins results in improper configuration, loss of enzyme function, and inability to maintain physiological processes critical to survival. Others, such as 3,4-dihydroxyphenylalanine (L-DOPA), interfere with tyrosinase (an enzyme critical to hardening of the insect cuticle). Over 300 non-protein amino acids are known, primarily from seeds of legumes (Harborne 1994). Proteinase inhibitors, produced by a variety of plants, interfere with insect digestive enzymes (Kessler and Baldwin 2002, Thaler et al. 2001).

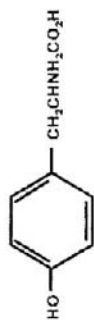
Cyanogenic glycosides are distributed widely among plant families (Fig. 3.7). These compounds are inert in living plant cells, but when crushed plant cells enter the herbivore gut, the glycoside is hydrolyzed by glucosidases into glucose and a cyanohydrin, that spontaneously decomposes into a ketone, or aldehyde, and hydrogen cyanide (Zenk and Juenger 2007). Hydrogen cyanide is toxic to most organisms because of its inhibition of cytochromes in the electron transport system (Harborne 1994).

Glucosinolates, characteristic of the Brassicaceae, have been shown to deter feeding and reduce growth in a variety of herbivores (Renwick 2002, Strauss et al. 2004). Intact glucosinolates confer some resistance to herbivores, but damaged plant cells release the enzyme myrosinase that converts glucosinolates to toxic isothiocyanates, nitriles and oxazolidinethiones that are more toxic (Hopkins et al. 2009). Rotem et al. (2003) reported that young larvae of the cabbage white butterfly, *Pieris rapae*, a specialized herbivore, showed reduced growth with increasing glucosinolate concentration in *Brassica napus* hosts, but that older larvae were relatively tolerant of glucosinolates.

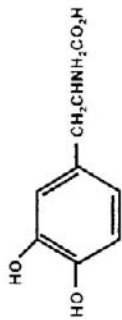
Alkaloids include over 5000 known structures from about 20% of higher plant families (Harborne 1994), ranging in molecular size and complexity from the relatively simple coniine (Fig. 3.7) to multicyclic compounds such as solanine. These compounds are highly toxic and teratogenic, even at relatively low concentrations, because they interfere with major physiological processes, especially cardiovascular and nervous system functions, but include important pharmaceuticals. D. Jackson et al. (2002) reported that larval weights and survival of tobacco budworm, *Helicoverpa virescens*, were negatively related to pyridine alkaloid concentrations among 18 tobacco, *Nicotiana tabacum*, cultivars. Survival after 8 wks declined from 60% to 0% as total alkaloid concentration increased from 0% to 2% w.w. Shonle and Bergelson (2000) found that generalist herbivore feeding on *Datura stramonium* was negatively correlated with hyposcyamine concentration; however, feeding by specialist flea beetles, *Epitrix* spp., was positively correlated with concentrations of scopolamine, indicating that this compound has become a phagostimulant for this adapted herbivore.

## 3. Elemental Defenses

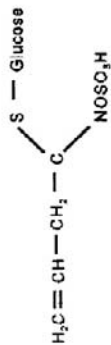
Some plants accumulate and tolerate high concentrations of toxic elements, including Se, Mn, Cu, Ni, Zn, Cd, Cr, Pb, Co, Al and As (Boyd 2004, 2007, 2009, Trumble and Sorensen 2008). In some cases, foliage concentrations of these metals can exceed 2% (Jhee et al. 1999). Although the function of such hyperaccumulation remains unclear, high concentrations in some plants confer protection against herbivores (Boyd 2004, 2007, Boyd and Moar 1999, Galeas et al. 2008, Pollard and Baker 1997, Vickerman et al. 2002).



Protein amino acid, tyrosine



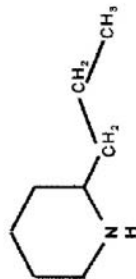
Non-protein amino acid, L-DOPA



Glucosinolate, sinigrin, from *Brassica campestris*



Cyanogenic glucoside, lotaustralin, from *Lotus comiculatus*



Alkaloid, conine, from *Conium maculatum*

**FIG. 3.7** Examples of nitrogenous defenses of plants. From Harborne (1994).

Boyd and Martens (1994) found that the larvae of the cabbage white butterfly, when fed *Thlaspi montanum* grown in high Ni soil, showed 100% mortality after 12 da, compared to 21% mortality for larvae fed on plants grown in low Ni soil. Hanson et al. (2004) reported that Indian mustard, *Brassica juncea*, can accumulate Se at levels up to 1000 mg kg<sup>-1</sup> d.w., even from low-Se soils. Green peach aphids, *Myzus persicae*, avoided Se-containing leaves when offered a choice of foliage from plants grown in Se or non-Se soil. In non-choice experiments, aphid population growth was reduced 15% at 1.5 mg Se kg<sup>-1</sup> d.w. and few, if any, aphids survived at leaf concentrations > 125 mg Se kg<sup>-1</sup>. Jhee et al. (1999) found that young larvae of *Pieris napi* showed no preference for high- or low-Zn leaves of *Thlaspi caerulescens*, but later-instar larvae showed highly significant avoidance of high-Zn leaves.

In a unique field study to compare arthropod diversity and intensity on Se-hyperaccumulator plants (*Astragalus bisulcatus* and *Stanleya pinnata*) and non-hyperaccumulator relatives (*Astragalus americanus*, *Camelina microcarpa*, *Descurainia pinnata*, and *Medicago sativa*), Galeas et al. (2008) found that non-hyperaccumulators hosted significantly higher (> 2×) arthropod abundance and species diversity per square meter of plant surface than did the hyperaccumulators. Arthropods on the hyperaccumulator plants contained 3–10-fold higher Se concentrations than those on non-hyperaccumulator plants, but >10-fold lower concentrations than did their hyperaccumulator hosts.

## D. Arthropod Defenses

### 1. Anti-predator Defenses

Arthropods also employ various defenses against predators and parasites. Physical defenses include hardened exoskeleton, spines, claws, and mandibles. Chemical defenses are nearly as varied as those that exist for plants. Hence, predaceous species also must be capable of evaluating and exploiting defended prey. The compounds used by arthropods generally belong to the same categories of compounds described above for plants.

Many insect herbivores sequester plant defenses for their own defense (Blum 1981, 1992, Boyd and Wall 2001, L. Brower et al. 1968). The relatively inert exoskeleton provides an ideal site for storage of toxic compounds. Toxins can be stored in scales on the wings of Lepidoptera, e.g., cardiac glycosides in the wings of monarch butterflies. Sawfly (Diprionidae) larvae store resinous defenses from host conifer foliage in diverticular pouches in the foregut, and regurgitate the fluid to repel predators (Codella and Raffa 1993). Conner et al. (2000) reported that males of an arctiid moth, *Cosmosoma myrodora*, acquire pyrrolizidine alkaloids systematically from excrescent fluids of certain plants, such as *Eupatorium capillifolium*, (but not from larval food plants) and discharge alkaloid-laden filaments from abdominal pouches on the female cuticle during courtship. This topical application significantly reduced predation upon females by spiders, *Nephila clavipes*, when compared to virgin females and females mated with alkaloid-free males. Additional alkaloid was transmitted to the female in seminal fluid, and was partially invested in the eggs.

Accumulation of Ni from *T. montanum* by a mirid plant bug, *Melanotrachus boydi*, protected it against some predators (Boyd and Wall 2001), but not against entomopathogens (Boyd 2002). Boyd (2009) reported that 15 insect species have been found to have whole-body concentrations of Ni that are in excess of 500 mg kg<sup>-1</sup>, and one species accumulates levels up to 3500 mg kg<sup>-1</sup>. Vickerman and Trumble (2003) found that a generalist predator, *Podisus maculiventris*, fed on beet armyworm, *Spodoptera exigua*, larvae reared



**FIG. 3.8** Defensive froth of an adult lubber grasshopper, *Romalea guttata*. This secretion includes repellent chemicals sequestered from host plants. From Blum (1992) with permission from the Entomological Society of America.

on a Se-enhanced diet showed slower growth and higher mortality when compared to predators that were fed larvae reared on a control diet. L. Peterson et al. (2003) reported that grasshoppers and spiders, as well as other invertebrates, had elevated Ni concentrations at sites where the Ni-accumulating plant, *Alyssum pintodasilvae*, was present, but not at sites where this plant was absent, indicating spread of Ni through trophic interactions. Concentrations of Ni in invertebrate tissues approached levels that are toxic to birds and mammals, suggesting that the use of hyperaccumulating plant species for bioremediation may, instead, spread toxic metals through food chains at hazardous concentrations.

Many arthropods synthesize their own defensive compounds (Meinwald and Eisner 1995). A number of Orthoptera, Hemiptera and Coleoptera exude noxious, irritating or repellent fluids or froths when disturbed (Fig. 3.8). Blister beetles (Meloidae) synthesize the terpenoid, cantharidin, and ladybird beetles (Coccinellidae) the alkaloid, coccinelline (Meinwald and Eisner 1995). Both compounds, which are unique to insects,

occur in the hemolymph and are exuded by reflex bleeding from leg joints to deter both invertebrate and vertebrate predators. Cantharidin is used medicinally to remove warts. Whiptail scorpions spray acetic acid from their “tail”, and the millipede, *Harpaphe*, sprays cyanide (Meinwald and Eisner 1995). The bombardier beetle, *Brachynus*, sprays a hot (100°C) cloud of benzoquinone produced by mixing, at the time of discharge, a phenolic substrate (hydroquinone), peroxide, and an enzyme catalase (Harborne 1994). The Formosan subterranean termite, *Coptotermes formosanus*, incorporates naphthalene, a chemical with general antiseptic properties, as well as a repellent effect on many animals, into their nest material (J. Chen et al. 1998).

Several arthropod groups produce venoms, primarily peptides, including phospholipases, histamines, proteases and esterases, for defense, as well as for predation (Habermann 1972, Meinwald and Eisner 1995, J. Schmidt 1982). Both neurotoxic and hemolytic venoms are found among insects. Phospholipases are particularly well-known, because of their high toxicity and their strong antigen activity capable of inducing life-threatening allergies. Venoms are most common among the Hymenoptera, and consist of a variety of enzymes, biogenic amines (such as histamine and dopamine), epinephrine, norepinephrine and acetylcholine. This combination produces severe pain and affects the cardiovascular, central nervous, and endocrine systems in vertebrates (J. Schmidt 1982). Melittin, found in bee venom, disrupts erythrocyte membranes (Habermann 1972). Some venoms include non-peptide components. For example, the venom of red imported fire ants, *Solenopsis invicta*, contains piperidine alkaloids, with hemolytic, insecticidal and antibiotic effects (Lai et al. 2008). Larvae of several families of Lepidoptera, especially Saturniidae and Limacodidae (Fig. 3.9), deliver venoms passively through urticating spines, although defensive flailing behavior by many species increases the likelihood of striking an attacker. A number of Hemiptera, Diptera, Neuroptera and Coleoptera produce orally-derived venoms that facilitate prey capture, as well as being used in defense (J. Schmidt 1982).



**FIG. 3.9** Physical and chemical defenses of a limacodid (Lepidoptera) larva, *Isa textula*. The urticating spines can inflict severe pain on attackers.

## 2. Antimicrobial Defenses

Arthropods also defend themselves against internal parasites and pathogens. Major mechanisms include ingested or synthesized antibiotics (Blum 1992, Tallamy et al. 1998), gut modifications that prevent growth or penetration by pathogens, and cellular immunity against parasites and pathogens in the hemocoel (Tanada and Kaya 1993). Behavioral mechanisms also may be employed for protection against pathogens.

Insects produce a variety of antibiotic and anticancer proteins that are capable of targeting foreign microorganisms (Boman and Hultmark 1987, Boman et al. 1991, Dunn et al. 1994, Hultmark et al. 1982, A. Moore et al. 1996, Morishima et al. 1995). The proteins are induced within as little as 30–60 minutes of injury or infection, they generally bind to bacterial or fungal membranes (increasing their permeability), they are effective against a wide variety of infectious organisms (Gross et al. 1996, Jarosz 1995, A. Moore et al. 1996), and they can persist for up to several days (Brey et al. 1993, Gross et al. 1996, Jarosz 1995). *Drosophila* spp., in particular, are known to produce more than ten different antimicrobial proteins (Cociancich et al. 1994).

Cecropin, originally isolated from cecropia moths, *Hyalophora cecropia*, is produced in particularly large amounts immediately before, and during, pupation. Similarly, hemolin (known in several moths) is produced primarily during embryonic diapause in the gypsy moth, *Lymantria dispar* (K. Y. Lee et al. 2002). Peak concentration during pupation may function to protect the internal organs of the insect from exposure to entomopathogens in the gut during diapause or metamorphosis (P. Dunn et al. 1994). In mosquitoes, cecropins may protect against some blood-born pathogenic microfiliae (Chalk et al. 1995). The entomopathogenic nematode, *Heterorhabditis bacteriophora*, produces anti-cecropin to permit its pathogenic bacteria to kill the host, the greater wax moth, *Galleria mellonella* (Jarosz 1995).

Lepidoptera susceptible to the entomopathogenic bacterium, *Bacillus thuringiensis*, typically have gut conditions of high pH and high concentrations of reducing substances and proteolytic enzymes. These conditions limit protein chelation by phenolics, but facilitate dissolution of the bacterial crystal protein and subsequent production of the delta-endotoxin. By contrast, resistant species have a lower gut pH and lower quantities of reducing substances and proteolytic enzymes (Tanada and Kaya 1993).

Cellular immunity is based on cell recognition of “self” and “non-self”, and includes endocytosis and cellular encapsulation. Endocytosis involves infolding of the plasma membrane and enclosure of foreign substances within a phagocyte, without penetration of the plasma membrane. This process removes viruses, bacteria, fungi, protozoans and other foreign particles from the hemolymph, although some of these pathogens then can infect the phagocytes. Cellular encapsulation occurs when the foreign particle is too large to be engulfed by phagocytes. Aggregation and adhesion by hemocytes forms a dense covering around the particle. Surface recognition may be involved because parasitoid larvae normally protected (by viral associates) from encapsulation are encapsulated when wounded or when their surfaces are altered (Tanada and Kaya 1993). Hemocytes normally encapsulate hyphae of the fungus, *Entomophthora egressa*, but do not adhere to hyphal bodies that have surface proteins protecting them from attachment of hemocytes (Tanada and Kaya 1993).

Behavioral mechanisms include grooming and isolation of infected individuals. Grooming may remove ectoparasites or pathogens. Myles (2002) reported that eastern subterranean termites, *Reticulitermes flavipes*, rapidly aggregate around, immobilize, and entomb individuals infected by the pathogenic fungus, *Metarhizium anisopliae*. Such behavior protects the colony from spread of the pathogen.

## E. Variation in Resource Quality

Organisms are subjected to a variety of selective factors in the environment. Intense herbivory is only one factor which affects plant fitness and expression of defenses (Bostock et al. 2001, Horvitz et al. 2005, Koricheva 2002). Factors that select most intensively or consistently among generations are likely to result in directional adaptation. Hence, the variety of specific biochemical defenses against herbivores is evidence of significant selection by herbivory. Nevertheless, at least some biochemical defenses have multiple functions (e.g., phenolics as UV filters, pigments and structural components, as well as defense); hence, selection for them is enhanced by the fact that they meet multiple plant needs. Similarly, insect survival is affected by climate, disturbances, host condition, as well as a variety of predators. Short generation time confers a capacity to adapt quickly to strong selective factors, such as particular plant defenses.

Defensive compounds are energetically expensive to produce, and their production competes with other metabolic pathways (e.g., I. Baldwin 1998, Chapin et al. 1987, Herms and Mattson 1992, Kessler and Baldwin 2002, Schwachtje et al. 2006, Stamp 2004, Stevens et al. 2007, Strauss and Murch 2004). Some, such as the complex phenolics and terpenoids, are highly resistant to degradation and cannot be catabolized to retrieve constituent energy or nutrients for other needs. Others, such as alkaloids and non-protein amino acids, can be catabolized and the nitrogen, in particular, that they contain can be retrieved for other uses. Such catabolism involves metabolic costs that reduce net gain in energy or nutrient budgets. Given sufficient water and nutrient availability, many plants are capable of tolerating, or even increasing, growth in response to herbivore feeding (Schwachtje et al. 2006, Stevens et al. 2007, Trumble et al. 1993, see [Chapter 12](#)).

Few studies have addressed the fitness costs of defense in terms of plant growth or reproduction, as predicted by the **growth–differentiation balance hypothesis** (Loomis 1932, Lorio 1993, Stamp 2004). I. Baldwin (1998) evaluated seed production by plants treated or not treated with jasmonate, a phytohormone that induces plant defenses (see below). Induction of defense did not significantly increase seed production of the plants that came under herbivore attack, but did significantly reduce the seed production of plants that were not attacked. Karban and Maron (2002) also found that the defenses that were induced via interplant communication may or may not increase plant fitness. Glynn et al. (2007) tested the hypothesis by comparing relative growth rate, net assimilation rate, and phenylpropanoid concentrations in two willow species, *Salix eriocephala* and *Salix sericea*, across soils with five fertility levels. A generally negative relationship between growth and defense over the fertility gradient supported the growth–differentiation hypothesis, but indicated the presence of complex interactions between plant physiological status and soil nutrient availability (see [Chapter 12](#)).

Given competition among metabolic pathways for limited energy and nutrients, production of defensive compounds should be sensitive to risk of herbivory or predation, as well as to environmental conditions (e.g., Chapin et al. 1987, Coley 1986, Coley et al. 1985, Glynn et al. 2003, Hatcher et al. 2004, Herms and Mattson 1992, M. Hunter and Schultz 1995, Karban and Niiho 1995). Plants at low risk of herbivory may produce fewer chemical defenses, or favor tolerance over defense (Stevens et al. 2007). L. Dyer et al. (2001) reported that *Piper cenocladum* plants hosting aggressive ant, *Pheidole bicornis*, colonies produced lower concentrations of amides to deter leaf-cutting ants and orthopterans, indicating a trade-off in costs between production of amides and support of ants. Nevertheless, the combination of defenses minimized losses to a diversity of herbivores. Expression of defenses depends on a number of factors that vary both spatially and temporally.

### 1. Variation Among Plants and Tissues

Plants vary widely in nutritional value. Some taxa are characterized by particular defensive compounds, making secondary chemistry a useful taxonomic characteristic (Waterman 2007). For example, ferns and gymnosperms rely primarily on phenolics, terpenoids and insect hormone analogues, whereas angiosperms more commonly produce alkaloids, phenolics and other types of compounds. However, most plants apparently produce compounds representing a variety of chemical classes (Harborne 1994, Newman 1990). Each plant species can be distinguished by a unique “chemical fingerprint” conferred by the particular combination of chemicals. Production of alkaloids and other nitrogenous defenses depends on the availability of nitrogen (Harborne 1994), but at least four species of spruce, *Picea* spp., and seven species of pines, *Pinus* spp., are known to produce piperidine alkaloids (Stermitz et al. 1994), despite low N concentrations. Plant defenses can reduce feeding by insects substantially, but insects also identify potential hosts by their chemical profile.

Plant tissues also vary in nutritional value and concentration of defensive compounds, depending on risk of, or response to, herbivory and value to the plant (Dirzo 1984, Feeny 1970, Paschold et al. 2007, Strauss et al. 2004). Foliage tissues, which are the source of photosynthates and have a high risk of herbivory, typically contain high concentrations of defensive compounds. Roots also produce defensive compounds (van Dam 2009). Defensive compounds in shoots are concentrated in bark tissues, perhaps reducing risk to sub-cortical tissues, which have relatively low concentrations of defensive compounds (e.g., Schowalter et al. 1998).

### 2. Variation Through Time

Defensive strategies change as plants or tissues mature (Dirzo 1984, Forkner et al. 2004). A visible example is the reduced production of thorns on foliage and branches of acacia, locust, and other trees when the crown grows above the grazing height of vertebrate herbivores (S. Cooper and Owen-Smith 1986, P. White 1988). Seasonal growth patterns also affect plant defense. Concentrations of condensed tannins in oak, *Quercus* spp., leaves generally increase from low levels at bud break to high levels at leaf maturity (Feeny 1970, Forkner et al. 2004). Consequently, herbivores tend to be most active during periods of leaf emergence (Coley and Aide 1991, Feeny 1970, M. Hunter and Schultz 1995, R. Jackson et al. 1999, Lowman 1985, 1992). Lorio (1993) reported that production of resin ducts by the loblolly pine, *Pinus taeda*, is restricted to the latewood that is formed during summer. The rate of earlywood formation in the spring determines the likelihood that southern pine beetles, *Dendroctonus frontalis*, that colonize the trees in spring, will sever resin ducts and induce pitch flow. Hence, tree susceptibility to colonization by this insect increases with stem growth rate. Ruel and Whitham (2002) also found that susceptibility to stem-boring moths, *Dioryctria albobittella*, increased among pinyon pines, *Pinus edulis*, that grew faster as juveniles, compared to slower-growing pines.

Concentrations of various defensive chemicals also change seasonally and annually as a result of environmental changes (Cronin et al. 2001, Mopper et al. 2004) and disturbance (M.D. Hunter and Forkner 1999, Nebeker et al. 1993). Cronin et al. (2001) monitored preferences of a stem-galling fly, *Eurosta solidaginis*, among the same 20 clones of goldenrod, *Solidago altissima*, over a 12 yr. period and found that preference for, and performance on, the different clones was uncorrelated between years. These data indicated that the interaction between genotype and environment affected the nutritional quality of clones for this herbivore. Increased exposure to UVB reduced concentration of gallic acid and increased



concentration of flavenoid aglycone in southern beech, *Nothofagus antarctica* (Rousseaux et al. 2004). Cipollini (1997) found that wind increased concentrations of peroxidase, cinnamyl alcohol-dehydrogenase and lignin in bean, *Phaseolus vulgaris*, and reduced oviposition and population growth of two-spotted spider mites, *Tetranychus urticae*.

### 3. Variation in Response to Injury

Plants balance the trade-off between the expense of defense and the risk of severe herbivory (Coley 1986, Coley et al. 1985). In addition to **constitutive defenses** that are normally present in plant tissues, plants initiate production of **inducible defenses** in response to injury (e.g., Haukioja 1990, Kaplan et al. 2008, Karban and Baldwin 1997, Klepzig et al. 1996, Nebeker et al. 1993, M. Stout and Bostock 1999, Strauss et al. 2004). Constitutive defenses are generally less specific compounds that are relatively effective against a wide variety of herbivores, whereas inducible defenses are more specific compounds, which are produced in response to particular types of injury (Hatcher et al. 2004). Herbivore feeding or regurgitants trigger plant wound hormones, particularly jasmonic acid, salicylic acid and ethylene (Creelman and Mullet 1997, Farmer and Ryan 1990, Karban and Baldwin 1997, Kessler and Baldwin 2002, Lou and Cheng 1997, McCloud and Baldwin 1997, Paschold et al. 2007, Ralph et al. 2006, Schmelz et al. 2006, 2007, Thaler 1999a, Thaler et al. 2001). These elicitors, in turn, induce production of defenses, such as proteinase inhibitors that interfere with insect digestive enzymes (Kessler and Baldwin 2002, Thaler et al. 2001, Zeringue 1987).

Plants often respond to injury with a combination of induced defenses that reflect expression of specific gene sets triggered by, and targeted against, a particular herbivore or pathogen species, but that also confer generalized defense against associated or subsequent herbivores or pathogens (Hatcher et al. 2004, Kessler and Baldwin 2002, T. Parsons et al. 1989, Ralph et al. 2006, D. Schmidt et al. 2005, Schwachtje and Baldwin 2008, M. Stout and Bostock 1999). Klepzig et al. (1996) reported that initial penetration of *Pinus resinosa* bark by bark beetles and associated pathogenic fungi was not affected by plant constitutive defenses, but elicited elevated concentrations of phenolics and monoterpenes, which significantly inhibited the germination of fungal spores or subsequent hyphal development. Continued insect tunneling and fungal development elicited further host reactions in healthy trees (but not stressed trees) that were usually sufficient to repel the invasion.

Plant defenses can be induced through multiple pathways that encode for different targets, such as internal specialists vs. more mobile generalists, and interaction (“cross-talk”) among pathways may enhance or compromise defenses against associated consumers (Kessler and Baldwin 2002, Rodriguez-Saona et al. 2005, Schultz and Appel 2005, Schwachtje and Baldwin 2008, M. Stout et al. 2006, Thaler 1999a, Thaler et al. 2001). Schmelz et al. (2006, 2007) demonstrated that the caterpillars of the fall armyworm, *Spodoptera frugiperda*, have oral secretions that contain inceptin, a small peptide which results from proteolytic cleavage of chloroplastic ATP synthase which originates from its cowpea, *Vigna unguiculata*, host. This unique product of herbivore digestion allows the plant to distinguish injury by herbivores from abiotic injury, and so triggers plant induction of anti-herbivore compounds. Little et al. (2007) studied the gene expression profile for arabidopsis, *Arabidopsis thaliana*, following oviposition by two pierid butterflies, *Pieris brassicae* and *P. rapae*. Histochemical analysis indicated that oviposition caused localized plant cell death, resulting in accumulation of callose and initiation of jasmonic acid and salicylic acid signaling pathways, indicating early perception of, and response to, incipient herbivory.

Thaler et al. (2002) found that wild-type tomato plants, that were capable of producing jasmonate in response to herbivory, produced more defensive chemicals and attracted more predators when damaged by herbivores than did a jasmonate-deficient tomato variety. Emission of jasmonate from damaged plants can communicate injury and elicit production of induced defenses by neighboring, even unrelated, plants (Dolch and Tschardt 2000, Farmer and Ryan 1990, Hudgins et al. 2004, Karban and Maron 2002, Karban et al. 2000, Schmelz et al. 2002, M. Stout et al. 2006, Thaler et al. 2001, Tschardt et al. 2001, see Chapter 8). Kessler et al. (2006) demonstrated that communication of injury via volatile chemicals may induce priming and accelerated defense in response to subsequent injury, rather than directly eliciting defensive chemicals, among neighboring plants. Herbivorous insects may have limited ability to detect, or learn to avoid, jasmonic acid (Daly et al. 2001). However, some insects are able to suppress jasmonate-induced defenses. Voelckel et al. (2001) demonstrated that oral secretions of the tobacco hornworm, *Manduca sexta*, suppress jasmonate-induced nicotine production in tobacco, *Nicotiana attenuata*, and instead trigger a burst of ethylene production. This induces the release of volatile terpenoids that, in turn, attract parasitoids (known to be sensitive to nicotine) to feeding *M. sexta* larvae.

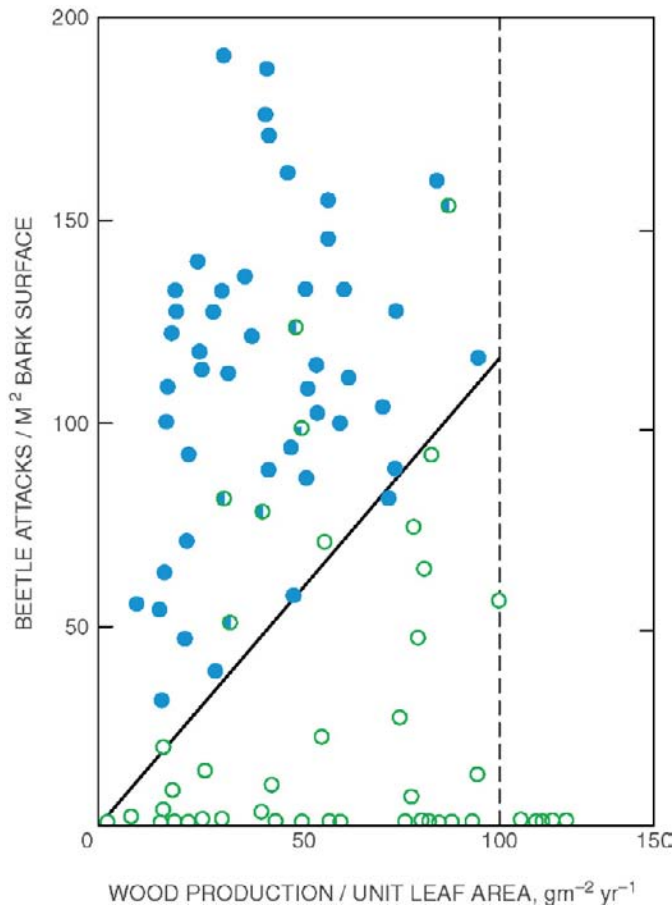
Molecular techniques have greatly enhanced our ability to explore the effects of defensive mechanisms. Kessler et al. (2004) and Paschold et al. (2007) genetically engineered tobacco plants to silence expression of the gene for jasmonate induction. Herbivore performance and feeding injury were significantly higher on the jasmonate-silenced plants than on untreated plants.

#### 4. Factors Affecting Expression of Defenses

Healthy plants growing under optimal environmental conditions should be capable of maintaining their full array of metabolic processes, and may provide greater nutritional value to insects capable of countering plant defenses. Such plants may allocate more resources to growth, relative to defenses, thereby compensating for losses to herbivores (Glynn et al. 2003, Trumble et al. 1993, see Chapter 12). By contrast, unhealthy plants, or plants growing under adverse environmental conditions (such as water or nutrient limitation) may sacrifice some metabolic pathways in order to maintain those which are the most critical to survival (e.g., Herms and Mattson 1992, Lorio 1993, Mattson and Haack 1987, Mopper et al. 2004, Tuomi et al. 1984, Wang et al. 2001, R. Waring and Pitman 1983). In particular, stressed plants often reduce their production of defensive chemicals in order to maximize the allocation of limited resources to maintenance pathways. They thereby become increasingly vulnerable to herbivores (Fig. 3.10).

Spatial and temporal variation in plant defensive capability creates a mosaic of food quality for herbivores (L. Brower et al. 1968). In turn, herbivore employment of plant defenses affects their vulnerability to predators (L. Brower et al. 1968, Malcolm 1992, Stamp et al. 1997, Traugott and Stamp 1996). Herbivore feeding strategies represent a trade-off between maximizing food quality and minimizing their vulnerability to predators (e.g., Schultz 1983, see below).

The frequent association of insect outbreaks with stressed plants (e.g., V.C. Brown 1995, Heliövaara 1986, Heliövaara and Väisänen 1986, 1993, W. Smith 1981) led T. White (1969, 1976, 1984) to propose the **Plant Stress Hypothesis**, i.e., that stressed plants are more suitable hosts for herbivores. However, some herbivore species prefer more vigorously-growing, apparently non-stressed plants (G. Waring and Price 1990), leading Price (1991) to propose the alternative **Plant Vigor Hypothesis**. Reviews by Koricheva et al. (1998) and G. Waring



**FIG. 3.10** The density of mountain pine beetle attacks necessary to kill lodgepole pine increases with increasing host vigor, measured as growth efficiency. The solid portion of circles represents the degree of tree mortality. The solid line indicates the attack level predicted to kill trees of a specified growth efficiency (index of radial growth); the dotted line indicates the threshold above which beetle attacks are unlikely to cause mortality. From R. Waring and Pitman (1983) with permission from John Wiley & Sons.

and Cobb (1992) indicated that response to plant condition varies widely among herbivore species. Schowalter et al. (1999) manipulated water supply to creosotebushes, *L. tridentata*, in New Mexico and found positive, negative, non-linear and non-significant responses to moisture availability among the assemblage of herbivore and predator species on this single plant species, demonstrating that, in some cases, both hypotheses are supported.

Regardless of the direction of response, water and nutrient subsidy or limitation clearly affect herbivore–plant interactions (Coley et al. 1985, M.D. Hunter and Schultz 1995, Mattson and Haack 1987). Therefore, resource acquisition by insects is moderated, at least in part, by ecosystem processes or environmental changes that affect the availability of water and nutrients for plants (Chapter 11).

Some plant species respond to increased atmospheric concentrations of CO<sub>2</sub> (carbon dioxide) by allocating more carbon to defenses, such as phenolics or terpenoids, especially if

other critical nutrients remain limiting (e.g., Arnone et al. 1995, Chapin et al. 1987, Grime et al. 1996, Kinney et al. 1997, Roth and Lindroth 1994). However, the way in which a plant responds to CO<sub>2</sub> enrichment does vary considerably among species, and will also vary as a result of environmental conditions such as light, water and nutrient availability (Bazzaz 1990, Dudt and Shure 1994, P. Edwards 1989, M. Hall et al. 2005, Niesenbaum 1992), with equally varied responses among herbivore species (e.g., Bezemer and Jones 1998, M. Hall et al. 2005, Salt et al. 1996, Watt et al. 1995). Zavala et al. (2008) demonstrated that elevated atmospheric CO<sub>2</sub> resulted in down-regulation of gene expression for defense-signaling compounds and, consequently, proteinase inhibitors. Such complexity of responses precludes general prediction of effects of CO<sub>2</sub> enrichment on insect–plant interactions (Bazzaz 1990, Watt et al. 1995).

Atmospheric deposition of nutrients which are typically limited, especially nitrogen, also affects insect–plant interactions, although the mechanisms involved are not clear. In general, nitrogen deposition increases growth and survival of individual insect herbivores, and promotes population growth (Throop and Lerdaу 2004). Such enrichment may permit plants to allocate more carbon to growth, and reduce production of non-nitrogenous defenses, making plants more vulnerable to herbivores, as predicted by the **Carbon/nutrient Balance Hypothesis** (Holopainen et al. 1995). M. Jones et al. (2004) reported that nitrogen deposition increased bark beetle activity and pine tree mortality. Zehnder and Hunter (2008) found that experimental simulation of nitrogen deposition in milkweed, *Asclepias tuberosa*, significantly increased foliar nitrogen concentration, plant biomass and per capita aphid, *A. nerii*, population growth, up to a point. However, increasing dietary nitrogen does not improve insect performance (Zehnder and Hunter 2009). Joern and Behmer (1998) reported that two grasshopper species differed in their growth and reproduction on diets varying in carbohydrate and nitrogen contents. For *Melanoplus sanguinipes*, reproductive rate showed a significant negative linear response to increasing carbohydrate and a significant quadratic response to increasing nitrogen, with a peak in egg production at 4% nitrogen. *Phoetaliotes nebrascensis*, on the other hand, showed a much weaker response to increasing nitrogen and no response to increasing carbohydrate.

Experimental fertilization has produced apparently contradictory results (Kytö et al. 1996, G. Waring and Cobb 1992). In some cases, this inconsistency may reflect non-linear responses of insects to increasing nitrogen in plant tissue (Joern and Behmer 1998, Zehnder and Hunter 2009) or different feeding strategies relative to plant allocation of subsidized nutrients (Kytö et al. 1996, Schowalter et al. 1999). In other cases, the conflicting results may reflect changes in nutrient balances, i.e., which nutrients were most limiting (Behmer 2009, Elser and Urabe 1999, Elser et al. 1996, Sterner and Elser 2002). Furthermore, plants differ in their allocation of subsidized nutrients, e.g., to increased production of N-based defenses vs. increased protein content. Other associated species also may influence insect response to subsidized nutrients. Kytö et al. (1996) found that positive responses to N fertilization at the individual insect level often were associated with negative responses at the population level, perhaps indicating indirect effects of fertilization on attraction of predators and parasites.

## F. Mechanisms for Exploiting Variable Resource Quality

Although plant defensive chemistry clearly affects insect performance, insects are still capable of feeding on defended hosts. Feeding preferences for less-defended hosts reflect one mechanism for avoiding defenses. However, insects exhibit a variety of mechanisms for improving plant suitability and/or avoiding, circumventing or detoxifying host defenses.

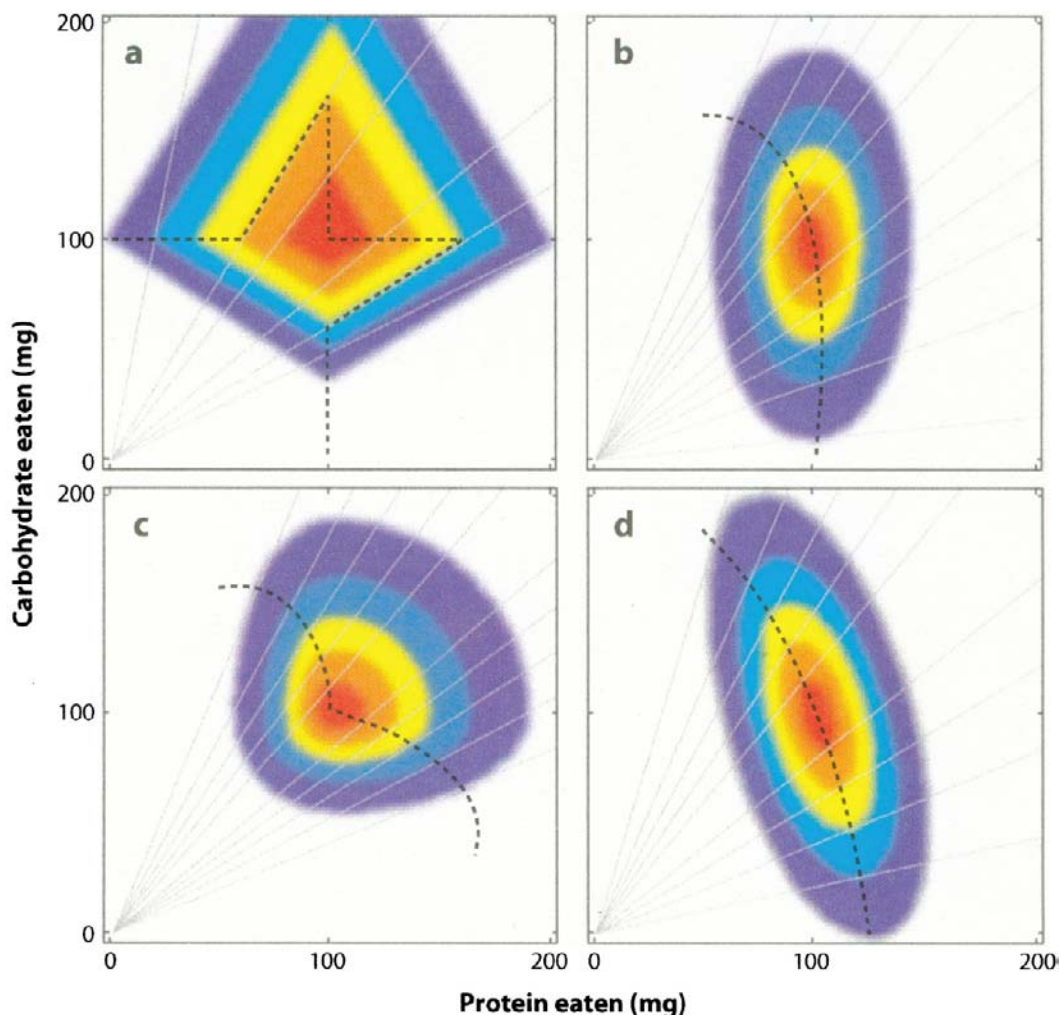
Gall-forming insects control gall formation and the chemical composition of colonized plant tissues, to the benefit of the insect (Saltzman et al. 2008). Gall formation in the plant apparently is induced by salivary compounds, rather than by mechanical injury (Sopow et al. 2003), and reflects the relationship between shoot length and the dose of gall induction stimulus (Flaherty and Quiring 2008). Gall chemistry returns to that of surrounding tissues if the gall-former is killed (Hartley 1998). The inner lining of galls is nutritive tissue that is rich in free amino acids (Price et al. 1987, Saltzman et al. 2008), but gall tissues outside this lining often are lower in nitrogen and higher in phenolics than are ungalled tissues (Hartley 1998). Y. Koyama et al. (2004) reported that the amount of amino acids exuding from leaves galled by the aphid, *Sorbaphis chaetosiphon*, was five times that from ungalled leaves. Furthermore, galls retained high amino acid concentrations throughout April, whereas amino acid concentrations declined rapidly during this period in ungalled leaves. Y. Koyama et al. (2004) also compared growth and reproduction of another aphid, *Rhopalosiphum insertum*, which can displace gall aphids or colonize ungalled leaves. Growth and reproduction by this aphid were significantly higher for colonies experimentally established in galls, compared to colonies established on ungalled leaves, indicating a positive effect of gall formation.

Some insects vector plant pathogens that induce favorable nutritional conditions, or inhibit host defense (e.g., Bridges 1983). However, not all insects that vector plant pathogens benefit from host infection (Kluth et al. 2002).

Insects that exploit nutritionally-poor resources require extended periods (several years to decades) of larval feeding, or other adaptations, in order to concentrate sufficient nutrients (especially N and P) to complete their development. Many have obligate associations with microorganisms that provide, or increase access to, limiting nutrients. Termites host mutualistic gut bacteria or protozoa that catabolize cellulose, fix nitrogen, and concentrate or synthesize other nutrients and vitamins needed by the insect (Mankowski et al. 1998). Termites and some other detritivores feed on feces (coprophagy) after sufficient incubation time for microbial digestion and enhancement of nutritive quality. If coprophagy is prevented, these insects often compensate by increasing consumption of detritus (McBrayer 1975). Aphids also may rely on endosymbiotic bacteria to provide requisite amino acids, vitamins or proteins necessary for normal development and reproduction (Baumann et al. 1995).

In general, food resources do not have the proper proportions of nutritional components that are required by animals for optimal nutrition. Insects have evolved a variety of strategies that govern the extent (trade-off) to which they will overeat a limiting nutrient and undereat an overabundant nutrient for optimal nutrition. Simpson and Raubenheimer (1993) pioneered efforts to describe the fundamental variables of nutritional homeostasis, i.e., the rules that govern trade-offs when diets have suboptimal nutrient balance. K.P. Lee et al. (2002, 2003), Raubenheimer and Simpson (1999, 2003) and Simpson et al. (2002) described nutrient balancing strategies for several grasshopper and caterpillar species varying in host range.

Behmer (2009) reviewed insect strategies for dealing with nutritional imbalances in food resources. According to the **Nutritional Heterogeneity Hypothesis** (Fig. 3.11), the amount of nutritionally imbalanced food that is consumed should reflect the probability of encountering food that is equally and oppositely imbalanced. This probability is higher for insects with wide diet breadth, compared to those which specialize on a single food source. Therefore, insects specializing on a particular resource will be unable to compensate for nutritional imbalance, and should evolve to use small amounts of imbalanced food most efficiently, rather than suffer fitness costs of overeating imbalanced food (Fig. 3.11b,



**FIG. 3.11** Four possible protein–carbohydrate regulation strategies revealed by intake array and fitness landscape plots. The thin gray lines are nutritional rails for different foods, and each thick, black dotted line is an intake array, which reveals the optimal strategy under different fitness cost scenarios. An intake array is constructed by connecting the protein–carbohydrate intake points obtained for each food. A fitness landscape corresponding to each nutrient regulation strategy has been fitted over nutrient space, and the red area in each plot indicates the fitness peak that corresponds to the protein–carbohydrate intake target (in these examples a 1:1 ratio). Fitness costs increase as distance from the intake target increases, and this is represented by colors becoming successively cooler. Panel *a* shows linear fitness costs, and the fitness contours are straight parallel lines in each of the quadrants around the intake target. The intake array corresponds with feeding to either a horizontal or vertical line that passes through the intake target, except where the feeding rail and the fitness contour are coincident. Panel *b* shows symmetrical quadratic costs. This regulatory strategy is most often seen in insect specialist herbivores. Panel *c* shows fitness contours and intake arrays that are ellipses in each of the quadrants around the intake target. Panel *d* shows symmetrical quadratic with interaction costs. Here the fitness contours are tilted ellipses, and the intake array is more linear than it is in panel *b*. This is the regulatory strategy most often seen in generalist insect herbivores. From Behmer (2009) with permission from Annual Reviews, Inc.

**closest distance rule**). In contrast, mobile generalists should eat as much as possible of imbalanced foods as they are encountered, with a high probability of achieving nutritional balance overall (Fig. 3.11d, **fixed proportion rule**).

Insects also must balance the fitness costs of ingesting harmful chemicals with the costs of regulating nutritional balance. Behmer's (2009) analysis indicated that plant defenses may have little effect on insect growth and survivorship when nutrient balance is optimal, but become increasingly deleterious, even fatal, as protein/carbohydrate imbalance increases.

Several mechanisms are employed to avoid or circumvent the defensive chemicals of a host. Some herbivores avoid exposure by moving to new resources in advance of an induced response (Paschold et al. 2007). Others sever the petiole or major leaf veins to inhibit translocation of induced defenses during feeding (Becerra 1994, Karban and Agrawal 2002). Sawflies (Diprionidae) sever the resin canals of their conifer hosts or feed gregariously to consume foliage before defenses can be induced (McCullough and Wagner 1993). Species that feed on plants with photooxidant defenses often feed at night or inside rolled leaves to avoid sunlight (Berenbaum 1987, Karban and Agrawal 2002).

Sequestration and excretion are alternative means of avoiding the effects of host toxins that cannot be detoxified. Sequestered toxins are transported quickly to specialized storage tissues (the exoskeleton or protected pouches), whereas remaining toxins are transported to the Malpighian tubules for elimination. Boyd (2009) noted that high-Ni insects had elevated concentrations in Malpighian tubules and exuviae, indicating that elimination was being used as a strategy for feeding on hyperaccumulating plants. Sequestered toxins also may be used in the insect's own defensive strategy (Blum 1981, 1992, Boyd and Wall 2001, Conner et al. 2000, L. Peterson et al. 2003).

Herbivorous insects produce a variety of catalytic enzymes, in particular those associated with cytochrome P-450, to detoxify plant or prey defenses (Feyereisen 1999, Karban and Agrawal 2002, W. Mao et al. 2006, Y. Mao et al. 2007). Some insects produce salivary enzymes that minimize the effectiveness of plant defenses. Salivary enzymes, such as glucose oxidase, applied to feeding surfaces by caterpillars, inhibit the expression of genes which are responsible for the activation of induced defenses (Bede et al. 2006, Felton and Eichenseer 1999, Musser et al. 2005, 2006). The saliva of Hemiptera gels into a sheath, which separates the insect's stylet from plant cells, perhaps reducing induced plant responses (Felton and Eichenseer 1999).

Digestive enzymes responsible for detoxification are typically microsomal monooxygenases, glutathione S-transferases, and carboxylesterases (Hung et al. 1990). These enzymes fragment defensive compounds into inert molecules. Microsomal monooxygenases provide a general-purpose detoxification system for most herbivores (Hung et al. 1990). In addition, more specific digestive enzymes are produced by species that encounter particular defenses. Ascorbate is a primary antioxidant found in the gut fluids of foliar-feeding insects, to reduce the effect of phenolic oxidation (Barbehenn et al. 2008). However, plant tissues that contain high concentrations of particularly reactive tannins can overwhelm this antioxidative capacity (Barbehenn et al. 2008). Exposure to plant toxins can induce the production of detoxification enzymes (Karbon and Agrawal 2002). For example, caterpillars feeding on diets containing proteinase inhibitors showed reduced function of particular proteinases, but responded by producing other proteinases that were relatively insensitive to dietary proteinase inhibitors (Broadway 1995, 1997). The compounds produced through detoxification pathways may be used to meet the insect's nutritional needs (Bernays and Woodhead 1982), as in the case of the sawfly, *Gilpinia hercyniae*, which detoxifies and uses the phenolics from its conifer host (Schöpf et al. 1982).

The ability to detoxify plant defenses may predispose many insects to detoxify synthetic insecticides (Feyereisen 1999, Plapp 1976). At least 500 arthropod species are resistant to major insecticides which are used against them, primarily through a limited number of resistance mechanisms that confer cross-resistance to plant defenses and structurally related toxicants, and, in some cases, to chemically unrelated compounds (Hsu et al. 2004, Soderlund and Bloomquist 1990). Le Goff et al. (2003) reported that several cytochrome P-450 genes code for detoxification of DDT, imidacloprid and malathion. In some cases, insect adaptation reflects mutations that reduce binding to, or sensitivity of, target enzymes (Hsu et al. 2004, 2006, 2008).

Gut pH is a factor that affects the chelation of nitrogenous compounds by tannins. Some insect species are adapted to digest food at high gut pH, in order to inhibit chelation. The insect thus is relatively unaffected by high tannin contents of its food. Examples include the gypsy moth feeding on oak, *Quercus* spp., and chrysomelid beetles, *Paropsis atomaria*, feeding on *Eucalyptus* spp. (Feeny 1969, Fox and Macauley 1977).

Many predaceous insects use their venoms primarily for subduing prey, and secondarily for defense. Venoms produced by predaceous Hemiptera, Diptera, Neuroptera, Coleoptera and Hymenoptera function to paralyze or kill prey (Schmidt 1982), thereby minimizing injury to the predator during prey capture. The carabid beetle, *Promecognathus*, which is a specialist predator on *Harpaphe* spp. and other polydesmid millipedes, avoids the cyanogenic secretions of its prey by quickly biting through the ventral nerve cord at the neck, inducing paralysis (G. Parsons et al. 1991). Nevertheless, host defenses increase handling time and risk of injury and mortality for the consumer (Becerra 1994, Schmidt 1982).

Diversion of limited resources to detoxification enzymes or to avoidance efforts all involve metabolic costs (Karban and Agrawal 2002, Kessler and Baldwin 2002). Lindroth et al. (1991) evaluated the effect of several specific nutrient deficiencies on detoxification enzyme activity in the gypsy moth. They found that larvae on a low-protein diet showed compensatory feeding behavior (although this was not enough to offset their reduced protein intake). Soluble esterase and carbonyl reductase activities increased in response to protein deficiency, but decreased in response to vitamin deficiency. Polysubstrate monooxygenase and glutathione transferase activities showed no significant response. Furthermore, Carrière et al. (2001b) reported that the resistance of the pink bollworm, *Pectinophora gossypiella*, to transgenic (Bt) cotton was associated with a reduced percentage emergence from diapause, compared to non-resistant bollworm, indicating the fitness costs of developing resistance strategies.

Some caterpillar species are able to suppress plant induction of defenses by means of prostaglandins in their oral secretions (Schultz and Appel 2004). Schultz and Appel (2004) reported that application of prostaglandin E<sub>2</sub> or oral regurgitant from gypsy moth or forest tent caterpillar, *Malacosoma disstria*, reduced production of tannins by wounded red oak, *Quercus rubra*, leaves by 30–90%, compared to untreated controls, which increased their tannin production by 50–80% in response to wounding.

## II. RESOURCE ACCEPTABILITY

The variety of resources and their physical and biochemical properties, including their defensive mechanisms, is too great in any ecosystem for any species to exploit all possible resources. The particular physiological and behavioral adaptations of insects, which enable them to obtain sufficient nutrients and to avoid toxic or indigestible materials, determine their feeding preferences, i.e., which resources they can or will exploit. Insects



that are adapted to exploit particular resources often lose their ability to exploit others. Even species that feed on a wide variety of resource types (e.g., host species) are limited in the range of resources they can exploit. For example, gypsy moths feed on a variety of plant species (representing many plant families) that share primarily phenolic defenses, whereas plants that utilize terpenoid or alkaloid defenses are not exploited (J. Miller and Hansen 1989).

Insects face an evolutionary choice between maximizing the efficiency with which they exploit a particular resource (**specialists**) or maximizing the range of resources that they are able to exploit (**generalists**). Specialists maximize the efficiency of exploiting a particular host plant through specific detoxification enzymes or avoidance strategies, thus minimizing the effect of host constitutive and induced defenses, but in so doing, they sacrifice the ability to feed on other plant species, which use different defenses (Bowers and Puttick 1988). By contrast, generalists maximize the range of resources that may be exploited through generalized detoxification or avoidance mechanisms, such as broad-spectrum microsomal monooxygenases. This strategy sacrifices efficiency in exploiting any particular resource, because unique biochemicals reduce digestion or survival (Bowers and Puttick 1988). Plant compounds that provide effective defense against generalists may be largely ineffective against specialists, and may even be phagostimulants for adapted species (Shonle and Bergelson 2000). Tallamy et al. (1997) reported that cucurbitacins (bitter triterpenes characterizing the Cucurbitaceae) deter feeding and oviposition by non-adapted mandibulate insect herbivores, but stimulate feeding by haustellate insect herbivores.

Generalists may benefit from a mixed diet by optimizing nutrient balances or through dilution of any single host's defensive compounds (Behmer 2009, Bernays et al. 1994), or by increasing their energetic efficiency on stressed hosts that have sacrificed production of defenses (Kessler et al. 2004). Kessler et al. (2004) demonstrated that when tobacco, *N. attenuata*, was transformed to silence its induced defense genes, it became suitable for new (non-adapted) herbivores, such as the western cucumber beetle, *Diabrotica undecimpunctata*, that fed and reproduced successfully. Generalists may be favored over specialists when host plants are rare or occur inconsistently. Wiklund and Friberg (2009) reported that fitness of a generalist pierid butterfly, *Anthocharis cardamines*, was increased by its ability to reproduce on any of a variety of host species, each of which varied widely in abundance and suitability over time.

Some generalists, which occur over large geographic areas, may be more specialized at the local level. Parry and Goyer (2004) demonstrated that the forest tent caterpillar is a composite of regionally specialized populations rather than an extreme generalist. In a reciprocal transplant experiment, tent caterpillars from Louisiana and Michigan, U.S., and Manitoba, Canada, were reared on the variety of hosts exploited by northern and southern populations. Tent caterpillars from northern populations showed greatest growth and survival on trembling aspen, *Populus tremuloides*, and red oak, *Quercus rubra*, which are both northern host species, and poorest growth and survival on water tupelo, *Nyssa aquatica*, which is a southern host species. Tent caterpillars from southern populations showed greatest growth and survival on water tupelo and poorest growth and survival on sugar maple, *Acer saccharum*, a northern host species. Feeding preferences reflect resource quality, susceptibility and acceptability.

Resource quality, as described above, represents the net nutritional value of the resource after deducting the energy and resources needed to detoxify or avoid defenses. Some of the nutrients in any food that is acquired must be allocated to production of detoxification enzymes, or to energy expended in searching for more suitable food. Although

diversion of dietary N to production of detoxification enzymes should be reduced if N is limiting, Lindroth et al. (1991) found little change in detoxification enzyme activity in response to nutrient deficiencies in gypsy moth larvae. However, defenses can have beneficial side effects for the consumer. M. Hunter and Schultz (1993) reported that phenolic defenses in oak leaves reduced the susceptibility of gypsy moth larvae to nuclear polyhedrosis virus.

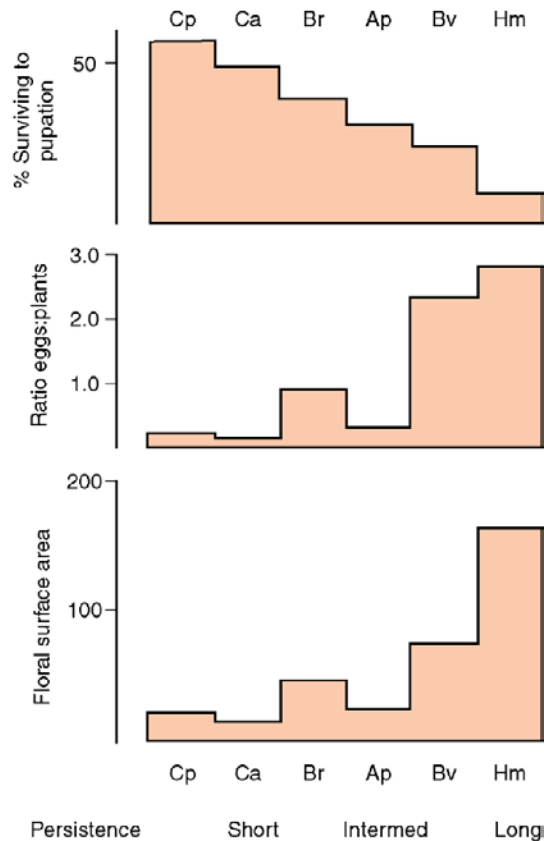
Resource susceptibility represents the physiological condition of the host (see above). Injury or adverse environmental conditions that stress organisms can impair their ability to defend themselves. Initially, stress may prevent expression of induced defenses, since this is an added cost, or it may reduce production of constitutive defenses but allow induction, as needed. Nitrogen limitation may prevent production of nitrogenous defenses but increase the production of non-nitrogenous defenses. In any event, impaired defenses reduce the cost of acquiring the resource. Therefore, specialists can allocate more energy and resources to growth and reproduction, and generalists can expand their host range as biochemical barriers are removed (Kessler et al. 2004).

Resource acceptability represents the willingness of the insect to feed on a discovered resource, given the probability of finding more suitable resources, or in view of other trade-offs. Most insects have relatively limited time and energy resources to spend searching for food. Hence, marginally suitable resources may become sufficiently profitable when the probability of finding more suitable resources is low, as in diverse communities composed primarily of non-hosts. Courtney (1985, 1986) reported that oviposition by a pierid butterfly, *A. cardamines*, among several potential host plant species was inversely related to the suitability of those plant species for larval development and survival (Fig. 3.12). The more suitable host species were relatively rare and inconspicuous compared to the less suitable host species. Given a short adult life span, butterfly fitness was maximized by laying eggs on the most conspicuous (apparent) plants, thereby ensuring reproduction, rather than by risking reproductive failure through continued search for more suitable hosts. Nevertheless, insects forced to feed on less suitable resources show reduced growth and survival rates (Bozer et al. 1996, Courtney 1985, 1986).

Searching insects initially identify acceptable hosts, and then select particular host tissues based on nutritional value. For example, insects may target particular portions of leaves, based on gradients in the ratio among amino acids along the leaf blade (Haglund 1980, K. Parsons and de la Cruz 1980). Particular heights on tree boles are also selected on the basis of gradients in ratios among amino acids and carbohydrates (Hodges et al. 1968).

Many insects feed on different resources at different stages of development. Most larval Lepidoptera feed on plant foliage, stems or roots, but many adults feed on nectar. Some cerambycid beetles feed in wood as larvae, but on pollen or nectar as adults. Most aquatic insects have terrestrial adults. Many aphids alternate generations between two host plant species (Dixon 1985). Clearly, these changes in food resources require changes in digestive abilities between life stages. Furthermore, population survival requires the presence of all of the necessary resources at an appropriate landscape scale.

The primacy of resource exploitation for development and survival places strong selective pressure on insects to adapt to changing host quality. This has led to the so-called “evolutionary arms race”, in which herbivory selects for new plant defenses, and the new plant defenses select for insect countermeasures. This process has driven reciprocal speciation in both plants and insects, with examples of cladograms for plants and associated insect that mirror each other (Becerra 1997). However, Agrawal and Fishbein (2008) tested some of the predictions of plant defense theory with a molecular phylogeny of 38



**FIG. 3.12** Trade-off between plant suitability for larval survival (top) and efficiency of oviposition site selection by adult pierids, *Anthocharis cardamines*, as indicated by the ratio of eggs per host species (middle) and plant apparency, i.e., floral surface area and longevity (bottom). Searching females preferentially oviposit on the most conspicuous plants although these are not the most suitable food plants for their larvae. Cp = *Cardamine pratensis*; Ca = *Cardamine amara*; Br = *Brassica rapa*; Ap = *Allaria petiolata*; Bv = *Barbarea vulgaris* and Hm = *Hesperis matronalis*. From Courtney (1985) with permission from John Wiley & Sons.

milkweed species, *Asclepias* and *Gomphocarpus* spp., and found a pattern of phyletic decline in the three most potent defensive traits (cardenolides, latex and trichomes) and an escalation in compensatory growth ability. Furthermore, M. Wise (2009) noted that any gain a plant might receive from increased resistance to one herbivore would be at least partially offset by increased damage from competing herbivores. These data suggest that selection ultimately may favor tolerance of herbivory over defensive ability.

### III. RESOURCE AVAILABILITY

The abundance, distribution and apparency of acceptable resources determine their availability in space and time to foraging organisms (Bozer et al. 1996, Courtney 1985, 1986, S. Eggert and Wallace 2003, see Chapters 6 and 7). Resources are most available when they are distributed evenly at non-limiting concentrations or densities. Organisms living under

such conditions need not move widely to locate new resources, and tend to be relatively sedentary. Microorganisms suspended in a concentrated solution of organic molecules (such as in eutrophic aquatic ecosystems or in decomposing detritus), and filter feeders and scale insects that capture resources from flowing solutions of resources may enjoy relatively non-limiting resources for many generations.

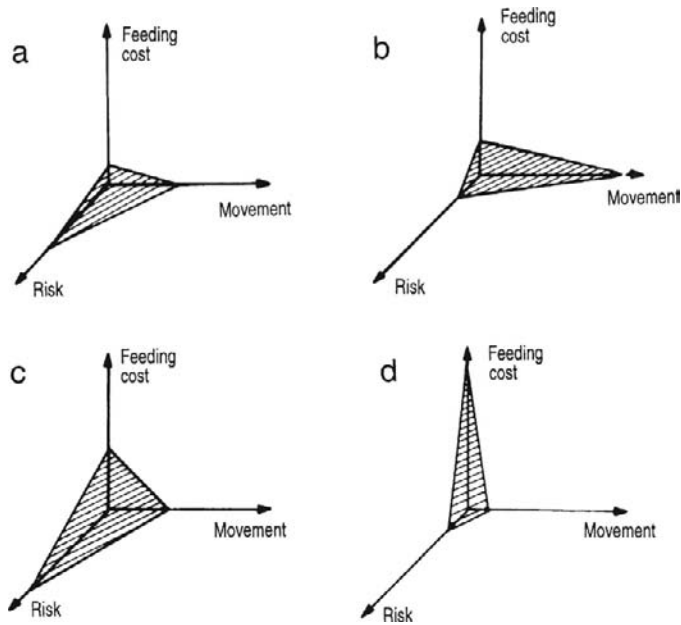
Necessary resources typically are less concentrated, available at suboptimal ratios with other resources, or may be distributed unevenly over space and time. This requires that organisms must select habitats where the required resources are most concentrated, or in most efficient balance, and must seek new sources as current resources become depleted. Insects and other animals employ various physiological and behavioral mechanisms to detect, orient toward, and move to concentrations of food.

### A. Discovering Suitable Resources

Resource quality or availability changes seasonally and annually in both temperate and tropical ecosystems. The life history phenology of many species is synchronized with periods of most favorable host nutritional chemistry, improving the chances that insects will find optimal food (Feeny 1970, R. Lawrence et al. 1997, Varley and Gradwell 1970). Diapause can be prolonged in cases of unpredictable availability of food resources, as for insects feeding on seeds of trees that produce seed crops irregularly (masting). Turgeon et al. (1994) reported that 70 species of Diptera, Lepidoptera and Hymenoptera, which feed on conifer cones or seeds, can remain in diapause for as long as seven years. In other words, insect populations often have considerable capacity to survive long periods of unsuitable resource conditions through diapause.

Most insects also must seek food resources which are unevenly distributed spatially. **Foraging theory** focuses on rules for optimization of diet quality, predation risk, and foraging efficiency (Behmer 2009, Kamil et al. 1987, Schultz 1983, Stephens and Krebs 1986, Townsend and Hughes 1981, see also [Chapter 4](#)). Profitable resources provide a gain to the consumer, but non-nutritive or toxic resources represent a cost in terms of time, energy or nutrient resources that must be expended in detoxification or continued search. Nutritional quality for herbivores varies considerably among tissue types, as well as among plants (Schultz 1983, Whitham 1983). Detrital resources also vary in their nutritional quality for detritivores (S. Eggert and Wallace 2007, Fonte and Schowalter 2004). Defensive chemicals reduce the nutritional value of the resource, but defended plants may be eaten when more suitable hosts are unavailable or not apparent (Courtney 1985, 1986). Continued search also increases the exposure of the herbivore to predators, or to other mortality agents. Schultz (1983) developed a trade-off surface to illustrate four foraging strategies for arboreal caterpillars (Fig. 3.13). Foraging can be optimized by searching for more nutritive food and risking attention of predators, accepting less nutritive food, or defending against predation. Natural selection can favor a reduction in cost along any of the three axes, within constraints of the other two costs.

Consumers should maximize foraging efficiency by focusing on resources or patches with high profitability (i.e., where hosts are concentrated or most apparent, the **Resource Concentration Hypothesis**), and ignore low profitability patches, until their resource value declines below the average for the landscape matrix (W. Bell 1990, Kareiva 1983). A foraging strategy represents a trade-off between costs (in terms of reduced growth and survival) of searching, costs of feeding on less suitable food, and costs of exposure to predators. Foraging efficiency can be improved by the ability to detect and orient toward cues that indicate suitable resources, and can be further enhanced by learning.



**FIG. 3.13** Trade-off planes of selected caterpillar foraging strategies. Costs of feeding (i.e., metabolic costs of digestion, reduced growth, etc.), movement (metabolic costs of reduced growth), and risks (e.g., probability of capture or reduced growth due to time spent hiding) increase in the direction of the arrows: a) selective diurnal feeder, b) selective nocturnal aposomatic feeder, c) diurnal cryptic feeder, and d) food mimic. From Schultz (1983).

## B. Orientation

Some insects forage randomly, eventually (at considerable individual risk) discovering suitable resources (Dixon 1985, Raffa et al. 1993). However, many insects respond to particular cues that indicate the availability of suitable resources. The cues to which searching insects respond may differ for each stage in the search process. For example, gross cues, indicative of certain habitats, might initially guide insects to a potentially suitable location. They then respond to cues that indicate suitable patches of resources, and finally focus on cues that are characteristic of the necessary resources (Bell 1990, Mustaparta 1984). Insects will search longer in patches where suitable resources have already been detected, than in patches without suitable resources, resulting in gradual increase in population density on hosts (Bell 1990, S. Risch 1980, 1981, Root 1973, Turchin 1988). Orientation toward cues involves the steps outlined in the following paragraphs.

### 1. Information Processing

Several types of information are processed by searching insects. Some cues are non-directional, but will alert insects to the presence of resources or will initiate search behavior. A non-directional cue may alter the threshold for response to other cues (cross-channel potentiation), or initiate behaviors that provide more precise information (Bell 1990). For example, flying bark beetles typically initiate a search for their host trees only after exhausting their fat reserves. Emerging adults of parasitic wasps gather information about their host from odors emanating from host frass or food plant material that is associated

with the emergence site (Godfray 1994). Wasps that emerge in the absence of these cues may be unable to identify potential hosts.

Directional information provides the stimulus for the insect to orient in the direction of the perceived resource. For example, detection of attractive chemicals without airflow initiates a non-directional, local search, whereas addition of airflow stimulates the orientation of the search upwind (Bell 1990). Accuracy of orientation increases with signal intensity, which in turn increases with density of the source, and decreases with distance from it (Elkinton et al. 1987, M. Stanton 1983). Concentration of attractive odors remains higher at greater distances from patches of high host density compared to patches of low host density (Fig. 3.14). Insects move upwind in circuitous fashion at low vapor concentration, but their movement becomes increasingly directed as vapor concentration increases upwind (Cardé 1996). Insects integrate visual, chemical, acoustic and geomagnetic signals to find their resources, switching from less precise to more precise signals as these become available (Bell 1990, J. Gould et al. 1978, Johnsen and Lohmann 2005, Schiff 1991).

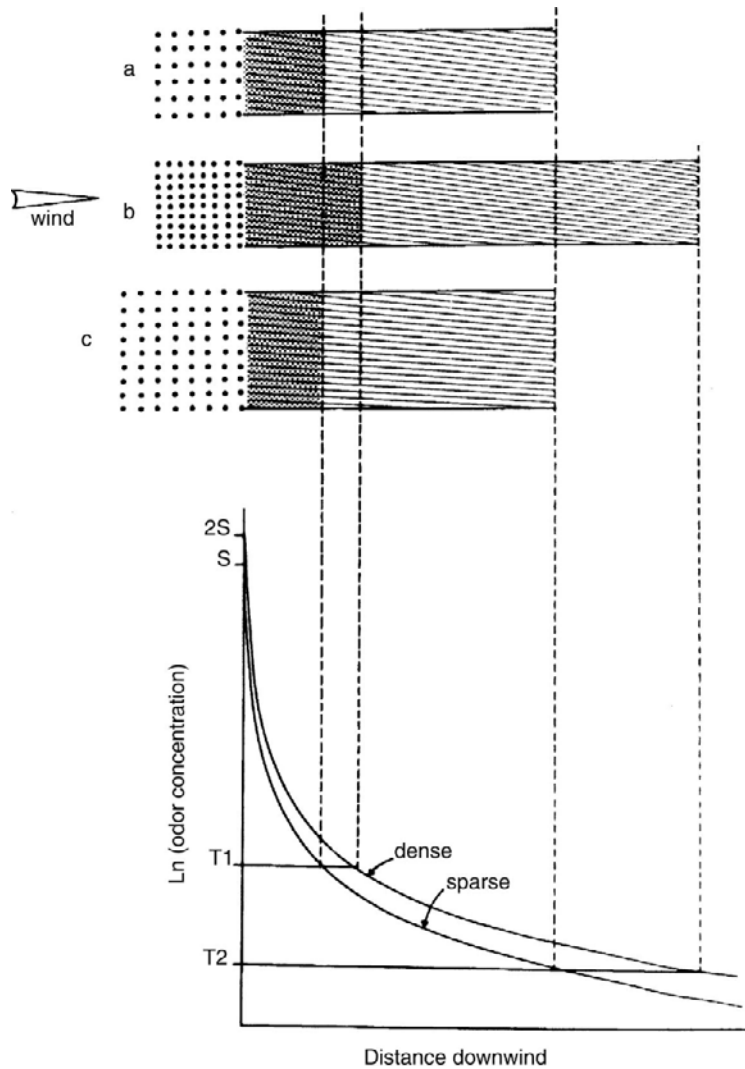
## 2. Responses to Cues

Many plant chemicals, especially monoterpenes, are highly volatile and provide strong long-distance signals to pollinators and herbivores. Plants that depend on dipteran pollinators produce odors that resemble those of carrion or feces to attract these insects. Sex pheromones (see Chapter 4) often are more attractive when mixed with host volatiles (e.g., Raffa et al. 1993), indicating prior discovery and evaluation of suitable hosts. Predators can be attracted to prey pheromones, or to odors from damaged plants that indicate the presence of prey (Kessler and Baldwin 2001, Stephen et al. 1993, Thaler et al. 2002, Turlings et al. 1990, 1993, 1995). Pheromones are known for more than 1000 insect species (Mustaparta 2002).

Recent studies have shown that the detection of relevant odors is genetically encoded, but response to them can be modified through learning (see below). Insects have relatively simple nervous systems, composed of receptor neurons that detect chemical signals, interneurons that integrate and convey information, and motor neurons that elicit the behavioral response. Olfactory receptor neurons are located in various sensilla, primarily on the antennae. Volatile chemicals diffuse through the cuticle and bind to receptor proteins that are highly selective for biologically relevant molecules (Mustaparta 2002). These proteins transport the odor molecule to a neuronal membrane that contains receptor proteins which are genetically coded for specific molecules; each receptor neuron expresses proteins specific to certain odor molecules. Therefore, the discriminatory power of an organism depends on the number of different neuron types that are present (Mustaparta 2002).

Having detected an attractive chemical, the insect begins a circuitous search pattern that involves continually turning in the direction of increasing odor concentration (Cardé 1996). However, odor plumes are disrupted by the turbulence resulting from habitat heterogeneity, e.g., surface irregularities of substrate or vegetation (Mafra-Neto and Cardé 1995, Murlis et al. 1992). For example, openings in forest canopies create sites of soil warming and convective eddies that dissipate chemical plumes (Fares et al. 1980). Elkinton et al. (1987) reported that the response of male gypsy moths to a caged female declined from 89% at 20 m distance to 65% at 120 m. Of those that responded, arrival at the female's cage declined from 45% at 20 m to 8% at 120 m (see Chapter 4).

At least some insects, as well as other animals, can orient along Earth's magnetic field (Johnsen and Lohmann 2005, Towne and Gould 1985). Monarch butterflies possess organically synthesized magnetic material (probably magnetite), that is concentrated in the thorax, which probably facilitates their orientation during migration (MacFadden and



**FIG. 3.14** Odor concentration downwind from patches of two host densities: the low density odor curve represents patches a and c, whereas the high density curve represents patch b. The curves reflect an ideal situation in which diffusion is overshadowed by convection due to wind. In still air, odor concentration cannot be changed by altering host-plant density. Attractive areas shown as rectangles are actually irregular in shape. Attractive zones for low-sensitivity herbivores (threshold T1) are stippled; those for a high-sensitivity herbivores (T2) are shaded. From M. Stanton (1983).

Jones 1985). Honey bees, *Apis mellifera*, contain magnetite that can amplify moderately strong external magnetic fields (MacFadden and Jones 1985, Schiff 1991, Towne and Gould 1985). Towne and Gould (1985) investigated the apparent misdirection (by up to 20°) in the honey bee waggle dance, and found that misdirection disappeared when the dances were oriented along the projection of the magnetic field lines onto the dance floor, regardless of the polarity of the magnetic field.

As an insect gets closer to an attractive source, other cues become important in distinguishing target resources. Visual cues include host silhouettes and radiant energy. Some species orient toward light. Many bark beetles are attracted to dark-colored silhouettes of tree boles, and can be attracted to other cylindrical objects, or prevented from landing on tree boles if they are painted white (Goyer et al. 2004, Strom et al. 1999). Aphids are attracted to young, succulent foliage and to older senescent foliage by longer-wavelength yellow, but this cue is not a good indicator of host species (Dixon 1985). Aphids, *Pemphigus betae*, migrating in autumn may discriminate among susceptible and resistant poplar trees, *Populus* spp., on the basis of prolonged leaf retention by more susceptible hosts (N. Moran and Whitham 1990). Some parasitic wasps detect their wood-boring hosts by means of infrared receptors on their antennae (Matthews and Matthews 2010).

Pollinator orientation to particular floral colors or patterns has been a topic of considerable research (Chittka and Menzel 1992, Heinrich 1979, Spaethe et al. 2001, Wickler 1968). Red and blue are most easily detected in open or well-lighted ecosystems, such as tropical canopies and grasslands, whereas white is more readily detected under low-light conditions, such as in forest understories. Spaethe et al. (2001) found that the foraging efficiency of the bumble bee, *Bombus terrestris*, depended on the degree of contrast between floral color and green foliage background when flowers were large. Search times were shortest for lemon yellow flowers and longest for red and UV-reflecting white. Search times increased for smaller flowers, and in these cases detection shifted to dependence on the green receptor signal, favoring detection of white flowers.

Ultraviolet designs provide important cues for insect pollinators. Insects can detect ultraviolet “runways” or “nectar guides” leading to the nectaries (Eisner et al. 1969, Heinrich 1979, Matthews and Matthews 2010). Some floral designs in the orchid genus *Ophrys* resemble female bees or wasps and produce odors that are similar to the mating pheromones of these insects. Male bees or wasps are attracted and pollinate these flowers while attempting to copulate (Wickler 1968).

Acoustic signals include the sounds produced by cavitating plant cells and by potential mates. Cavitation, the collapse of cell walls as turgor pressure falls, produces an audible signal that provides a valuable cue to stressed plants (Mattson and Haack 1987). Attraction to this signal may partly explain the association of bark beetles with water-stressed trees (Mattson and Haack 1987, Raffa et al. 1993).

Non-hosts can interfere with insect orientation. Hambäck et al. (2003) reported that leaf-feeding beetles, *Galerucella* spp., were significantly less abundant on purple loosestrife, *Lythrum salicaria*, that were surrounded by non-host or artificial shrubs, than on hosts that were surrounded by other hosts. Similarly, Meisner et al. (2007) reported that the presence of alfalfa aphids, *Therioaphis maculata*, reduced the foraging efficiency of the hymenopteran parasitoid, *Aphidius ervi*, for its primary host, pea aphids, *Acyrtosiphum pisum*. Non-attractive or repellent odors from non-hosts can mix with attractive odors in the airstream of more diverse ecosystems and disrupt orientation. Verbenone and 4-allylanisole, found in the resin of various non-host angiosperm trees, repel some conifer-feeding bark beetle species, and so protect host trees that reside within the repellent plume (Hayes et al. 1994, Poland et al. 1998, Q. Zhang and Schlyter 2004).

If an insect successfully reaches the source of attractive cues, it engages in close-range gustatory, olfactory, or sound reception (Dixon 1985, Raffa et al. 1993, Städler 1984). Contact chemoreceptive sensilla generally are located on its antennae, mouthparts or feet (Dixon 1985, Städler 1984). These sensors provide information about the nutritive value and defensive chemistry of the resource (R. Chapman 2003, Raffa et al. 1993). Some plant chemicals

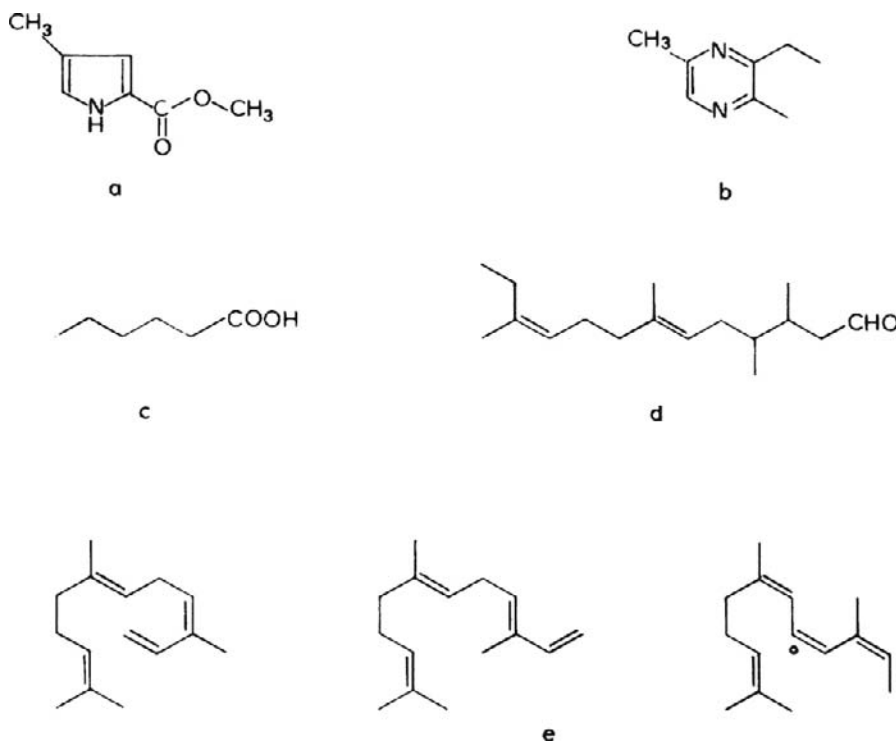


act as phagostimulants, or as deterrents (R. Chapman 2003, Q. Zhang and Schlyter 2004). For example, cucurbitacins deter feeding and oviposition by non-adapted mandibulate insects, but are phagostimulants for diabroticine chrysomelid beetles (Tallamy and Halaweish 1993). Predators also may avoid prey that contain toxic or deterrent chemicals (Stamp et al. 1997, Stephens and Krebs 1986). Many parasitic wasps avoid hosts that were marked chemically by wasps that oviposited previously in that host (Godfray 1994). Because hosts support only a limited number of parasitoid offspring, often no more than one, avoidance of previously parasitized hosts reduces competition among larvae within a host.

### 3. Attraction of Conspecific Insects

Some insects can communicate the presence of suitable resources to conspecific insects. Cooperation facilitates acquisition of shared resources or larger prey and improves mating success (see Chapter 4).

Attractive and repellent chemicals produced by insects (pheromones) advertise the locations of suitable resources and potential mates (Fry and Wehner 2002, Raffa et al. 1993, Rudinsky and Ryker 1976). Most insects produce pheromones, but those of the Lepidoptera, bark beetles and social insects have been studied most widely. Social insects mark foraging trails to guide other members of their colony to food resources and back to the colony (B. Smith and Breed 1995, Traniello and Robson 1995). A variety of chemical structures are used to mark trails (Fig. 3.15). A plant-derived monoterpene, geraniol,



**FIG. 3.15** Trail pheromones of myrmicine ants. a) *Atta texana* and *Atta cephalotes*, b) *Atta sexdens rubropilosa* and *Myrmica* spp., c) *Lasius fuliginosus*, d) *Monomorium pharaonis*, e) *Solenopsis invicta*. From J. Bradshaw and Howse (1984) with permission from Chapman and Hall.

is obtained from flower scents, concentrated and used by honey bees to mark trails and floral resources (Harborne 1994). Trail markers can be highly effective. The trail marker produced by the leaf-cutting ant, *Atta texana*, is detectable by ants at concentrations of  $3.48 \times 10^8$  molecules  $\text{cm}^{-1}$ , indicating that 0.33 mg of the pheromone would be sufficient to mark a detectable trail around the world (Harborne 1994). Although trail markers were once thought to be species specific, more recent work has shown that multiple species may use the same compounds as trail markers, with varying degrees of interspecific recognition (Traniello and Robson 1995). Furthermore, synthetic analogues, e.g., 2-phenoxyethanol, also may elicit trail following behavior, despite its having little structural similarity to the natural counterpart (J. Chen et al. 1988).

Acoustic signals (stridulation) from potential mates, especially when combined with attractive host cues, advertise the discovery and evaluation of suitable resources. Stridulation contributes to optimal spacing and resource exploitation by colonizing bark beetles (Raffa et al. 1993, Rudinsky and Ryker 1976). Visual signals are illustrated by the elaborate movements of the “bee dance” used by honey bees to communicate distance and direction to suitable resources to other foragers (F. Dyer 2002, von Frisch 1967).

### C. Learning

Learning improves the efficiency of resource acquisition. Although an unambiguous definition of learning has eluded ethologists, a simple version involves any repeatable and gradual improvement in behavior that can be attributable to experience (Papaj and Prokopy 1989, Shettleworth 1984). Learning is difficult to demonstrate, because improved performance with experience can result from maturation of neuromuscular systems rather than from learning (Papaj and Prokopy 1989). Although learning by insects has been appreciated less widely than has learning by vertebrates, various insect groups have demonstrated considerable learning capacity (cf., Cunningham et al. 1998, Daly et al. 2001, Drukker et al. 2000, Dukas 2008, Gong et al. 1998, J. Gould and Towne 1988, Gutiérrez-Ibáñez et al. 2007, A. Lewis 1986, Li and Liu 2004, Meller and Davis 1996, Raubenheimer and Tucker 1997, Schnierla 1953, von Frisch 1967, Wehner 2003).

Schnierla (1953) was among the first to report that ants can improve their ability to find food in a maze. However, ants learned more slowly and applied experience less efficiently to new situations than did rats. Learning is best developed in the social and parasitic Hymenoptera and in some other predaceous insects, but also has been demonstrated in phytophagous species representing six orders (Dukas 2008, Li and Liu 2004, Papaj and Prokopy 1989). Furthermore, learning during larval stages has been shown to persist through metamorphosis to adult memory (Gutiérrez-Ibáñez et al. 2007). Molecular and neurological studies have contributed to the understanding of the mechanisms of memory formation (R. Davis 2005). Ishimoto et al. (2009) demonstrated that 20-hydroxyecdysone is instrumental in the formation of long-term memory in adult *Drosophila melanogaster*. Several types of learning by insects have been identified: habituation, imprinting, associative learning, observational learning, and even cognition.

Habituation is the loss of responsiveness to an unimportant stimulus, as a result of continued exposure. Habituation may explain parasitoid emigration from patches that are depleted of unparasitized hosts (Papaj and Prokopy 1989). Although host odors are still present, a wasp is no longer responsive to these odors.

Imprinting is the acceptance of a particular stimulus in a situation in which the organism has an innate tendency to respond. Parasitic wasps imprint on host or plant stimuli at

the site of adult emergence. Odors from host frass or the host's food plant that are present at the emergence site offer important information that can be used by the emerging wasp during subsequent foraging (W. Lewis and Tumlinson 1988). A number of studies have demonstrated that if the parasitoid is removed from its cocoon or reared on artificial diet, it may be unable to learn the odor of its host or its host's food plant and, hence, be unable to locate hosts (Godfray 1994).

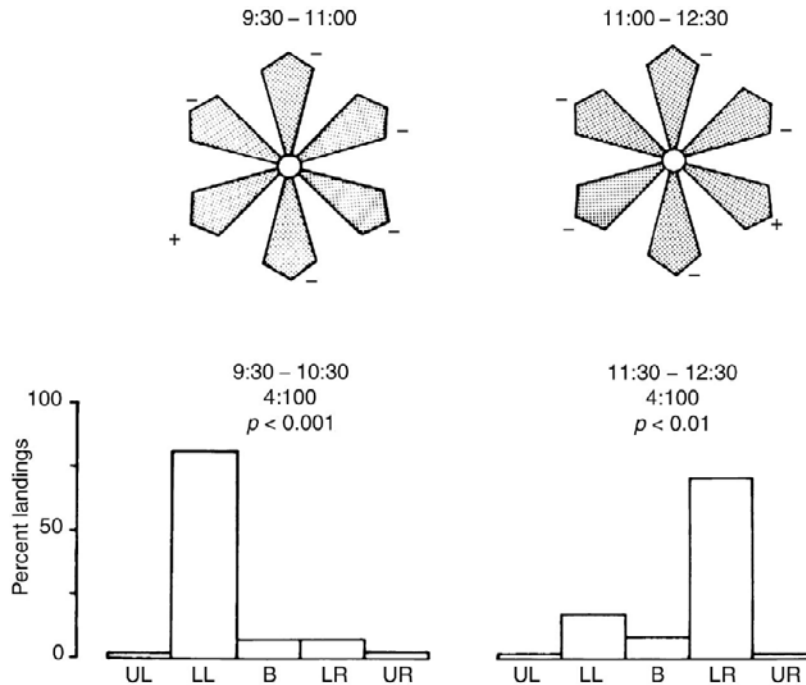
Associative learning is the linking of one stimulus with another, based on a discerned relationship between the two stimuli. Most commonly, the presence of food is associated with cues that are consistently associated with food. Several types of associative learning have been identified.

Classical conditioning involves substitution of one stimulus for another. For example, parasitic wasps will respond to empty food trays after they have learned to associate food trays with hosts, or they will respond to novel odors after learning to associate them with provision of hosts (Godfray 1994).

Operant conditioning, or trial-and-error learning, is demonstrated when an animal learns to associate its behavior with reward or punishment and then tends to repeat or avoid that behavior, accordingly. Association of ingested food with post-ingestion malaise often results in subsequent avoidance of that food (Papaj and Prokopy 1989). Laboratory experiments by Stamp (1992) and Traugott and Stamp (1996) demonstrated that predatory wasps initially attack caterpillars that sequester plant defenses, but after a few days will reject unpalatable prey.

Pollinators provide some of the best examples of insect learning, because floral structures present difficult challenges to the acquisition of nectar and/or pollen resources. Honey bees, trained to approach a particular flower from different directions at different times of day, will subsequently approach other flowers from the direction that was appropriate to the time of day at which rewards were provided during training (Fig. 3.16). Fry and Wehner (2002) and Horridge (2003) found that honey bees can distinguish pattern and landmark orientations, and will return to food resources even when the associated landmark orientation is altered. Similarly, experience enables traplining bumble bees, *Bombus impatiens*, to travel more rapidly among floral resources, acquire more nectar, and increase foraging performance in competition with less experienced individuals (Ohashi and Thomson 2009, Ohashi et al. 2008). However, certain spatial configurations of floral resources limit the optimization of a foraging route, suggesting that trapliners may select plants representing an appropriate spatial configuration (Ohashi et al. 2007). A. Lewis (1986) reported that cabbage white butterflies became more efficient at obtaining floral rewards by selectively foraging on a particular floral type, based on experience. Such floral fidelity can increase pollination efficiency (see Chapter 13). However, increased nectar foraging on larval food plants may increase the likelihood that females will use the same plant for nectar foraging and oviposition and thereby increase herbivory on pollinated plants (Cunningham et al. 1998, 1999).

Associative learning improves performance of parasitic Hymenoptera (Godfray 1994). Information gathered during searching contributes to increased efficiency of host discovery (W. Lewis and Tumlinson 1988). Searching wasps learn to associate host insects with plant odors, including odors induced by herbivory (Fukushima et al. 2002). Subsequently, they preferentially search similar microhabitats (Godfray 1994, Steidle 1998). However, exposure to new hosts or hosts in novel habitats can lead to increased responsiveness to new cues. Bjorksten and Hoffmann (1998) reported that such learned stimuli can be remembered for at least 5 days.



**FIG. 3.16** Honey bees can remember how to approach specific flowers in relation to time of day. Bees trained to land at different positions (+) of an artificial flower at different times in the morning subsequently preferred to land on the petal on which they were trained during the same part of the morning. From J. Gould and Towne (1988).

Insects are capable of complex associative learning. Raubenheimer and Tucker (1997) trained locust, *Locusta migratoria*, nymphs to distinguish between food containers that differed in color, by using a synthetic diet which was deficient in either protein or carbohydrate. Feeding from both containers in the arena was necessary to obtain a balanced diet. The nymphs subsequently were deprived of either protein or carbohydrate, and then tested for their ability to acquire the deficient nutrient. Locusts most frequently selected food containers of the color that was previously associated with the deficient nutrient, regardless of color or whether the nutrient was protein or carbohydrate. Wäckers et al. (2002) demonstrated that parasitoid wasps, *Microplitis croceipes*, could learn multiple tasks representing feeding and reproduction. Stach et al. (2004) found that honey bees can learn multiple conditioning patterns and generalize their response to novel stimuli based on linkage among conditioned stimuli.

Foraging social insects must be able to return to the colony site. Honey bees displaced from their colony tend to follow a search pattern that consists of frequently-occurring, relatively short, straight segments that are punctuated by infrequent longer segments that, in turn, are punctuated by rare, very long segments. This flight pattern can cover a greater area more efficiently than a random walk of the same length, and it maximizes the probability of locating the hive (A. Reynolds et al. 2007). Several social Hymenoptera remember geometric features along paths between their colony and food resources. Bisch-Knaden and Wehner (2003) demonstrated that desert ants, *Cataglyphis fortis*, learned to associate local foraging trail vectors with individual cylindrical

landmarks during homebound runs, but not during outbound runs. However, ants returning to the nest initially reverse the outbound vector, then start a systematic search for the nest, indicating that these ants cannot learn separate inbound and outbound vectors that are not 180° reversals, and that recalibration during homebound runs is dominated by the outbound vector (Wehner et al. 2002). Ants thus are able to reach the nest along the shortest route, and later return to the food source by 180° vector reversal. Lent et al. (2009) found that foraging ants remembered direction to a landmark and continued a straight or curving direction of travel between intermittent sightings of landmarks (due to uneven terrain). Wystrach and Beugnon (2009) reported that ants made rotational errors in locating a target in a rectangular arena, similar to vertebrates, and suggested that ants may be guided more by a global view of large features than by individual landmarks that could be confused.

Observational learning occurs when animals gather information and modify their behavior in response to observation of other individuals. Observational learning is epitomized by social bees that communicate the location of rich floral resources to other members of the colony through the “bee dance” (F. Dyer 2002, J. Gould and Towner 1988, Srinivasan et al. 2000, von Frisch 1967). Movements of this dance inform other foragers of the direction and distance to a food source. Direction relative to the sun or Earth’s magnetic field is conveyed by orientation on the vertical dance floor (Johnsen and Lohmann 2005, Towner and Gould 1985). Distance apparently is estimated visually from the rate of change in image angle and communicated to hive members as 17.7° of image motion per millisecond of waggle dance (Srinivasan et al. 2000).

Cognition, characterized by awareness, memory and judgment, is evident when information that was gathered during previous experiences is applied to novel situations. This basic form of thinking is widely associated with higher vertebrates. However, J. Gould (1986) demonstrated that honey bees are capable of constructing cognitive maps of their foraging area. Bees were trained to forage at either of two widely separated sites, then captured at the hive and transported in the dark to an unfamiliar site, the same distance from the hive but in a different direction, within a complex foraging area (open areas interspersed with forest). If released bees were disoriented, or could not accommodate a sudden change in landmarks, they should fly in random directions. If they had only route-specific landmark memory and were familiar with a foraging route to their release point, they should be able to return to the hive and fly from there to their intended destination (site to which they had been trained). Only if bees are capable of constructing true cognitive maps should they fly from the release point directly to their intended destination. All bees flew directly to their intended destinations. Although some studies indicate limits to large-scale cognitive mapping by bees (Dukas and Real 1993, Menzel et al. 1998), substantial evidence indicates that honey bees construct and maintain at least a local geometric representation, referenced to the time of day, of landmarks and line angles to floral resources (J. Gould 1985, 1986, J. Gould and Towner 1988). Wei et al. (2002) further demonstrated that honey bees intensively examine the area around a food source, through “learning flights”. Bees turn back and face the direction of the food source and surrounding landmarks, then circle around, before returning to the hive. The duration of learning flights increases with the sugar concentration of the food and the visual complexity of the surrounding landmarks, and it is longer after initial discovery of food than during subsequent reorientation. These results indicate that bees adjust their learning effort in response to the need for visual information. Such advanced learning greatly facilitates the efficiency with which resources can be acquired.

## IV. SUMMARY

Insects, as for all organisms, must acquire energy and material resources to synthesize the organic molecules necessary for the life processes of maintenance, growth and reproduction. Dietary requirements reflect the size and life stage of the insect, and the quality of food resources available to it. Insects exhibit a variety of physiological and behavioral strategies for finding, evaluating and exploiting potential resources.

Defensive chemistry of plants and insects affects their quality as food, and is a basis for host choice by herbivorous and entomophagous insects, respectively. The nutritional value of resources varies among host species, among tissues of a single organism, and even within tissues of a particular type. Production of defensive chemicals is expensive in terms of energy and nutrient resources, and may be sacrificed during unfavorable periods (such as during water or nutrient shortages or following disturbances) so that more immediate metabolic needs may be met. Such hosts become more vulnerable to predation.

Insect adaptations to avoid or detoxify host defenses determine host choice and range of host species that may be exploited. Generalists exploit a relatively broad range of host species, but exploit each host species rather inefficiently, whereas specialists are more efficient in exploiting a single or a few related hosts that produce similar chemical defenses. Major advances have occurred in the past decade in understanding of specific plant genes that confer defense against insects and of insect genes that govern tolerance or detoxification.

Chemicals also communicate the availability of food and provide powerful cues that influence insect foraging behavior. Insects are capable of detecting food resources over considerable distances. Perception of chemical cues that indicate availability of hosts is influenced by concentration gradients in air or water, environmental factors that affect downwind or downstream dispersion of the chemical, and sensitivity to particular odors. Orientation to food resources over shorter distances is affected by visual cues (such as color or pattern) and acoustic cues (such as stridulation). Once an insect finds a potential resource, it engages in tasting or other sampling behaviors that permit evaluation of resource acceptability.

Efficiency of resource acquisition may improve over time as a result of learning. Although much of insect behavior may be innate, learning has been documented for many insects. The ability to learn among insects ranges from simple habituation to continuous unimportant stimuli, to widespread associative learning among both phytophagous and predaceous species, to observational learning, and even cognitive ability. Learning represents the most flexible means of responding to environmental variation and allows many insects to adjust to changing environments during short lifetimes.

This page intentionally left blank

# Resource Allocation

- I. Resource Budget
- II. Allocation of Assimilated Resources
  - A. Foraging and Dispersal Behavior
  - B. Mating Behavior
  - C. Reproductive and Social Behavior
  - D. Competitive, Defensive and Mutualistic Behavior
- III. Efficiency of Resource Use
  - A. Factors Affecting Efficiency
  - B. Trade-offs
- IV. Summary

## How are energy and nutrient budgets measured?

The efficiency with which various organisms assimilate food resources and allocate the acquired energy and nutrients to growth and reproduction largely determines their fitness. High efficiency can translate into population growth, a variable of considerable interest to resource managers, who are concerned with controlling pest populations or conserving threatened species. The energy and nutrients that are converted into biomass also represents an important food resource for various predators and, ultimately, detritivores.

The earliest work on energy and nutrient budgets was directed toward improved agricultural production. Attention to insects developed during the 1950s, when ecosystem ecology began to address pathways of energy and radioisotope fluxes through ecosystems. Using relatively crude mass balance techniques, Smalley (1960) calculated assimilation by salt marsh grasshoppers, *Orchelimum fodicinium*, as the sum of respiration (measured as replacement by water of respired CO<sub>2</sub> absorbed by sodalime in a flask immersed in water) and growth, or production, during the life cycle. Results indicated ingestion of 650 cal hr<sup>-1</sup>, assimilation of 180 cal hr<sup>-1</sup>, egestion of 470 cal hr<sup>-1</sup>, and an assimilation efficiency of 27%. Crossley (1966) used radioactive cesium, <sup>137</sup>Cs, that occurred in both plants and the chrysomelid beetle, *Chrysomela knabi*, larvae in a contaminated area to calculate an ingestion rate of 9.2 mg plant larva<sup>-1</sup> da<sup>-1</sup>, which was similar to a rate of 9 mg larva<sup>-1</sup> da<sup>-1</sup> that was measured in the laboratory using conventional mass balance techniques. Early investigation of allocation by sap-sucking insects involved fine pipettes to measure the mass of honeydew they excreted, as an estimate of ingestion, and concentrations of carbohydrates and nutrients in sap and honeydew, to estimate assimilation of energy and nutrients (Auclair 1958, 1959, Banks and Nixon 1959, M. Day and Irzykiewicz 1953, M. Day and McKinnon 1951, Mittler 1958, M. Watson and Nixon 1953).



These studies demonstrated that insects convert ingested energy and nutrients into biomass more efficiently (5–17%) than do homeothermic organisms (<2%) (Wiegert and Evans 1967), the difference indicating the energetic cost of homeothermy. Although high production efficiency vs. homeothermy represents an important ecological trade-off, the high production efficiency of insects underlies their ability to maintain population viability while providing the food base for a wide variety of predators.

## INTRODUCTION

INSECTS ALLOCATE THEIR ACQUIRED RESOURCES IN VARIOUS WAYS, depending on the energy and nutrient requirements of their physiological and behavioral processes. In addition to basic metabolism, foraging, growth and reproduction, individual organisms also allocate resources to pathways that influence their interactions with other organisms and abiotic nutrient pools (Elser et al. 1996). The efficiency with which an organism assimilates acquired food resources and converts these to growth and reproduction largely determines its fitness.

Interestingly, much of the early data on energy and nutrient allocation by insects was a byproduct of studies during 1950–70 on the anticipated effects of nuclear war on radioisotope movement through ecosystems (e.g., Crossley and Howden 1961, Crossley and Witkamp 1964). Research focused on the effects of radioactive fallout on organisms which affect human health and food supply. The effects of radiation on insects and other arthropods were perceived to be of special concern, because of the recognized importance of these organisms to human health and crop production. Radioactive isotopes, such as <sup>32</sup>P, <sup>137</sup>Cs (assimilated and allocated as is K), and <sup>85</sup>Sr (assimilated and allocated as is Ca), became useful tools for tracking the assimilation and allocation of nutrients through organisms, food webs, and ecosystems.

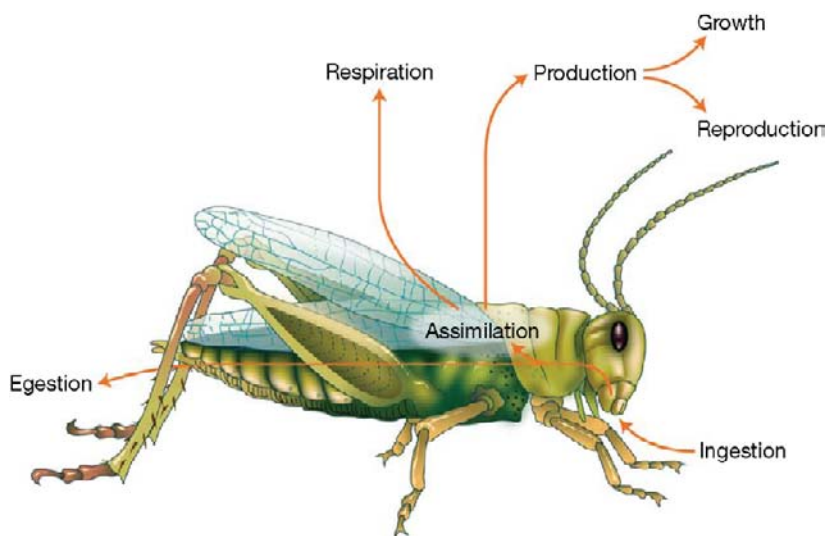
## I. RESOURCE BUDGET

The energy or nutrient budget of an individual can be expressed by the equation

$$I = P + R + E \quad (4.1)$$

in which I=ingestion, P=production, R=respiration, E=egestion, and I–E = P + R = assimilation (A). Energy is required to fuel metabolism, so only part of the energy that has been assimilated is available for growth and reproduction (Fig. 4.1). The remainder is lost through respiration. Insects and other heterotherms require little energy to maintain thermal homeostasis. Hence, arthropods generally respire only 60–90% of assimilated energy, compared to > 97% for homeotherms (Fitzgerald 1995, Golley 1968, Phillipson 1981, Schowalter et al. 1977, Wiegert and Petersen 1983).

Resource limitation clearly affects growth, survival and reproduction. For many holometabolous insects, the resources that are required by adults for reproduction must be accumulated during larval feeding stages. Boggs and Freeman (2005) demonstrated that food limitation for larvae of the butterfly, *Speyeria mormonia*, reduced adult body mass and survival (which reduced fecundity, but independently of larval treatment), compared to well-fed larval treatment. By contrast food limitation for adults directly reduced fecundity (Boggs and Ross 1993), demonstrating a survival/reproduction trade-off across life stages.



**FIG. 4.1** Model of energy and nutrient allocation by insects and other animals. Ingested food is only partially assimilable, depending on digestive efficiency. Unassimilated food is egested. Assimilated food used for maintenance is lost as carbon and heat energy; the remainder is used for growth and reproduction.

The availability of some nutrients can affect an organism's use of others, i.e., acquisition and allocation pathways are based on differences in ratios among various nutrients between a resource and the needs of an organism (Behmer 2009, Elser et al. 1996, Holopainen et al. 1995, see Chapter 3). Generalists, to some extent, can select multiple food resources that collectively achieve nutritional balance (Behmer 2009, K.P. Lee et al. 2002, 2003). Specialists, on the other hand, must optimize the trade-off between overeating nutrients that occur in excess and undereating nutrients that occur in insufficient amounts (Behmer 2009, Raubenheimer and Simpson 2003, Simpson et al. 2002). **Ecological stoichiometry** and **metabolic theory** have become useful approaches to account for mass balances among multiple nutrients and energy as they flow within and among organisms (A. Allen et al. 2002, Behmer 2009, J. Brown et al. 2004, Elser and Urabe 1999, Sterner and Elser 2002, see Chapters 3 and 9).

Arthropod species vary considerably in their requirements for, and assimilation of, energy and various nutrients (Joern and Behmer 1998). Reichle et al. (1969) and Gist and Crossley (1975) reported significant variation in cation accumulation among forest floor arthropods, and Schowalter and Crossley (1983) reported significant variation in cation accumulation among forest canopy arthropods. Caterpillars and sawfly larvae accumulated the highest concentrations of K and Mg, and spiders accumulated the highest concentrations of Na, among arboreal arthropods (Schowalter and Crossley 1983), and millipedes accumulated the highest concentrations of Ca among litter arthropods (Reichle et al. 1969, Gist and Crossley 1975). Although N is frequently limiting for herbivores, an excess may be a liability, requiring elimination of toxic ammonia. Therefore, insect performance may decline if the diet contains more than an optimal nitrogen content (Behmer 2009, Joern and Behmer 1998, Sterner and Elser 2002).

Resources which vary in nutritional quality affect the efficiency with which they are assimilated. For example, S. Eggert and Wallace (2007) reported that several aquatic

**TABLE 4.1** Assimilation efficiency, A/I, gross production efficiency, P/I, and net production efficiency, P/A, for larval stages of the saturniid moth, *Hemileuca oliviae*. Means underscored by the same line are not significantly different ( $P > 0.05$ ).

Instar	1	2	3	4	5	6	7	Total
A/I	0.69	0.64	0.60	0.55	0.48	0.43	0.41	0.54
P/I	0.41	0.26	0.28	0.22	0.25	0.26	0.20	0.23
P/A	0.59	0.43	0.47	0.42	0.56	0.63	0.53	0.52

Reproduced from Schowalter et al. (1977) with kind permission from Springer Science+Business Media.

detritivore taxa assimilated wood epoxylon (the surface biofilm of microbes, fragmented detritus and exoenzymes) more efficiently (26–36%) than they did leaf detritus (9–17%), although they consumed more leaf detritus ( $0.09 - 0.47 \text{ g g}^{-1} \text{ da}^{-1}$  vs.  $0.04 - 0.07 \text{ g g}^{-1} \text{ da}^{-1}$ ).

Assimilation efficiency also varies among developmental stages. Schowalter et al. (1977) found that the assimilation efficiency of the range caterpillar, *Hemileuca oliviae*, declined significantly from 69% for first instars to 41% for the prepupal stage (Table 4.1). Respiration by pupae was quite low, amounting to only a few percent of larval production. This species does not feed as an adult, so resources acquired by larvae must be sufficient for adult dispersal and reproduction.

## II. ALLOCATION OF ASSIMILATED RESOURCES

Assimilated resources are allocated to various metabolic pathways. The relative amounts of resources used in these pathways depend on several factors, including stage of development, quality of food resources, physiological condition, and metabolic demands for physiological processes (such as digestion and thermoregulation), activities (such as foraging and mating), and interactions with other organisms (including competitors, predators and mutualists). For example, many immature insects are relatively inactive and expend energy primarily in feeding and defense, whereas adults expend additional energy and nutrient resources for dispersal and reproduction. Major demands on energy and nutrient resources include foraging activity, mating and reproduction, and competitive and defensive behavior.

### A. Foraging and Dispersal Behavior

Many insects gain protected access to food (and habitat) resources through symbiotic interactions, i.e., where they live on, or in, food resources (see Chapter 8). Specialized phytophagous species spend most or all of their developmental period on host food resources. A variety of myrmecophilous or termitophilous species are tolerated, or even share food with their hosts, as a result of morphological (size, shape and coloration), physiological (chemical communication), or behavioral (imitation of ant behavior, trophallaxis) adaptations (Wickler 1968). Resemblance to ants also may confer protection from other predators (see below). Living within a food source minimizes the energy expenditure needed for acquiring food.

However, many phytophagous and predaceous species must search for suitable food and habitat resources. Dispersal activity is an extension of foraging activity and also constitutes an energy expense. Foraging, and dispersal-related travel, brings an animal into contact with a wider variety of resources. As discussed in Chapter 3, feeding on a wider variety of resources enables an insect to achieve nutritional balance, by compensating for imbalanced resources with a combination of resources that are imbalanced in equal and complementary ways (Behmer 2009, K.P. Lee et al. 2002, 2003, Raubenheimer and Simpson 2003, Simpson et al. 2002).

Searching for food or a suitable habitat requires investment of energy and nutrients. Energy and nutrients invested in anatomical features that permit locomotion may conflict with other physiological or morphological needs, e.g., wing development and flight improving foraging and dispersal ability at the expense of reproductive ability (Table 4.2). Zera and Zhao (2006) demonstrated this trade-off through differential use of radiolabeled glycine by wing-dimorphic crickets, *Gryllus firmus*. The longer-winged, flight-capable morph oxidized a larger proportion of glycine and converted most into triglycerides to fuel flight, whereas the flightless morph utilized more glycine in ovarian protein for greater reproduction (S. Tanaka and Suzuki 1998).

Energy expenditure varies among foraging strategies, depending on the distances covered and the efficiency of orientation toward resource cues (see Chapters 2 and 3). Flight is more energy-efficient and allows greater distance to be travelled in shorter time than does walking, and efficiency increases with flight speed (Heinrich 1979), thus enabling flying insects to cover large areas with relatively small energy reserves. Hunting requires a considerable expenditure of energy in searching for prey, but a high return, depending on ability to detect prey from a distance. Detection can be increased by orienting toward prey odors, or plant odors that are indicative of prey. Accordingly, many predaceous species are attracted to the mating pheromones of their prey (Stephen et al. 1993) or to volatile chemicals that are released by plants in response to herbivory (Turlings et al. 1993). Social insects improve their foraging efficiency by rapidly recruiting nestmates to discovered resources (see Chapter 3). Ambushers either sit and wait or employ traps to capture their prey. As examples, dragonfly larvae hide in the substrate of aquatic habitats and grasp prey coming within reach, antlion larvae excavate conical depressions in loose sandy soil that prevents escape of ants and other insects that wander into the pit, and

**TABLE 4.2** Allocation of assimilated resources to body mass and thoracic muscle at adult eclosion and adult fecundity and longevity, when provided 16 mg food the day after adult eclosion, for long- and short-winged morphs of the cricket, *Modicogryllus confirmatus*.

Morph	Sex	Body Mass (Dry mg)	% Fat	Thoracic Muscle Mass (Wet mg)	Fecundity (No. eggs)	Longevity (Days)
Short-winged	M	30 ± 5	18 ± 5	4.6 ± 1.0		8 ± 2
	F	35 ± 6	23 ± 7	5.2 ± 1.2	24 + 10	9 ± 2
Long-winged	M	34 ± 4	21 ± 3	12.7 ± 1.4		12 ± 2
	F	39 ± 5	25 ± 4	13.3 ± 1.9	4 + 6	13 ± 2

Modified from S. Tanaka and Suzuki, (1998), with permission from the authors and Elsevier.

web-spinning spiders construct sticky orbs or tangled webs that trap flying or crawling insects. Movement costs are minimal for these species, but prey encounter is uncertain. The frequency of such encounters can be increased by selecting ambush sites that are situated along prey foraging trails, near prey nest sites, etc.

Larger animals travel more efficiently than do smaller ones, expending less energy for a given distance traversed. Hence, larger animals often cover larger areas in search of resources. Flying against the wind requires additional energy expenditure. Orchard bees, *Euglossa imperialis*, extend their hind legs ventrally to improve stability at high wind speeds, but this position increases drag by 30%, increasing the energy expenditure of flight (Combes and Dudley 2009).

The nutritional value of the food resource affects the degree of energy and nutrient investment that may be expended in seeking it. Bumble bees, *Bombus* spp., forage on low-value resources only at high temperatures when the insects do not require large amounts of energy to maintain sufficiently high body temperature for flight (W. Bell 1990, Heinrich 1979, 1993). As described in Chapter 3, prey with defense mechanisms require the production of detoxification enzymes or expenditure of energy to avoid the defenses or avoid injury during prey capture. Alternatively, energy must be expended for continued search if the resource cannot be acquired successfully. However, searching behavior may also bring the forager to the attention of predators (Folgarait and Gilbert 1999, Schultz 1983), and expenditure of carbohydrate for locomotion may result in a relative excess of nitrogen. Since most insects are short-lived, as well as energy-limited, they often maximize fitness by accepting less suitable, but more available or apparent, resources in lieu of continued search for superior resources (Behmer 2009, Courtney 1985, 1986, Kogan 1975). Van der Zee et al. (2002) offered desert locust, *Schistocerca gregaria*, nymphs food choices that varied in nutritional composition (from high protein, low carbohydrate to low protein, high carbohydrate) and also in distance apart. They found that movement of nymphs between the dishes which offered complementary nutritional value declined as the distance between them increased, demonstrating a trade-off between movement and diet optimization.

The actual energy costs of foraging have been measured rarely. McNab (1963) proposed that the area (home range, H) required for an individual to acquire sufficient resources is proportional to the individual's mass (M) to the  $\frac{3}{4}$  power:

$$H \propto M^{\frac{3}{4}} \quad (4.2)$$

However, subsequent research has demonstrated that mobile animals require larger home ranges than would be predicted by the  $\frac{3}{4}$  power equation, reflecting the larger home ranges and maintenance costs necessary to defend portions that overlap with home ranges of conspecific individuals (Jetz et al. 2004). Swenson et al. (2007) tested the relationship for sessile ant lion, *Myrmeleon* sp., and concluded that the  $\frac{3}{4}$  power equation applied to the pit density of these sessile animals, despite competition for pit space.

Fewell et al. (1996) compared the ratios of benefit to cost for a canopy-foraging tropical ant, *Paraponera clavata*, and an arid-grassland seed-harvesting ant, *Pogonomyrmex occidentalis* (Table 4.3). They found that the ratio ranged from 3.9 for nectar foraging *P. clavata* and 67 for predaceous *P. clavata* to > 1000 for granivorous *P. occidentalis*. Differences were due to the quality and amount of the resource, the distance traveled and the individual cost of transport. In general, the smaller *P. occidentalis* had a higher ratio of benefit to cost because of the higher energy return of seeds, shorter average foraging distances and lower energy cost per meter traveled. The results indicated that *P. clavata* colonies have similar

daily rates of energy intake and expenditure, potentially limiting colony growth, whereas *P. occidentalis* colonies have a much higher daily intake rate, compared to expenditure, reducing the likelihood of short-term energy limitation.

Insects produce a variety of biochemicals to exploit food resources. Insects that feed on chemically-defended food resources often produce more-or-less specific enzymes to detoxify these defenses (see Chapter 3). On one hand, the production of detoxification enzymes (typically complex, energetically- and nitrogen-expensive molecules) reduces the net energy and nutritional value of food. On the other hand, these enzymes permit the exploitation of a resource, and derivation of nutritional value, that otherwise would be unavailable to the insect. Some insects not only detoxify host defenses, but also digest the detoxified products for use in their own metabolism and growth (e.g., Schöpf et al. 1982), thereby compensating for the expense of detoxification.

Social insects employ communication to recruit nestmates to discovered resources. Ants produce trail pheromones that provide an odor trail to guide other members of a colony to food resources, and back to the colony (Fig. 3.15, see Chapter 3). Honey bees, *Apis mellifera*, have the most sophisticated communication among invertebrates. The elaborate movements of the “bee dance” communicate both the distance and the direction to suitable resources to other foragers (F. Dyer 2002, von Frisch 1967, see Chapter 3). By these means of communication, and by recruitment of large numbers of nestmates, social insects can exploit discovered resources quickly.

Agricultural systems typically concentrate particular crop species over large areas, reducing the expense of searching for suitable food resources for adapted insects. For example, the Colorado potato beetle, *Leptinotarsa decemlineata*, probably originated in South America and subsisted on wild solanaceous hosts. Spread of the buffalo burr, *Solanum rostratum*, into western North America facilitated the spread of the beetle, but it was not a pest until the westward movement of settlers brought it into contact with cultivated potato in the Midwest during the late 1800s (Hitchner et al. 2008, C. Riley 1883, Stern et al. 1959), eventually allowing it to spread to Europe. Similarly, the cotton boll weevil, *Anthonomus grandis*, co-evolved with scattered wild *Gossypium* spp., including *Gossypium hirsutum*, in tropical Mesoamerica. The spread of citrus cultivation in the 1890s provided food resources that could sustain overwintering adults, allowing the

**TABLE 4.3** Components of the benefit-to-cost (B/C) ratio for individual *Paraponera clavata* and *Pogonomyrmex occidentalis* foragers.

	<i>Paraponera</i>		<i>Pogonomyrmex</i>
	Nectar Forager	Prey Forager	
Energy cost per m ( $J m^{-1}$ )		0.042	0.007
Foraging trip distance (m),		125	12
Energy expenditure per trip (J)		5.3	0.09
Average reward per trip (J)	20.8	356	100
B/C	3.9	67	1111

From Fewell et al. (1996) with kind permission of Springer Science+Business Media.

insect to spread into the subtropical cotton-growing regions of south Texas and northern Argentina (Showler 2009). Subsequently, rapid reproduction in the spring by adults that had survived winter dormancy permitted their spread throughout the U.S. Cotton Belt (Showler 2009).

## B. Mating Behavior

Attracting a mate and courtship behavior are often highly elaborated and ritualized, which can be costly in energetic terms. Nevertheless, such behaviors that distinguish species, especially sibling species, ensure appropriate mating and reproductive success, and therefore contribute to individual fitness through the improved survival of offspring from selected mates.

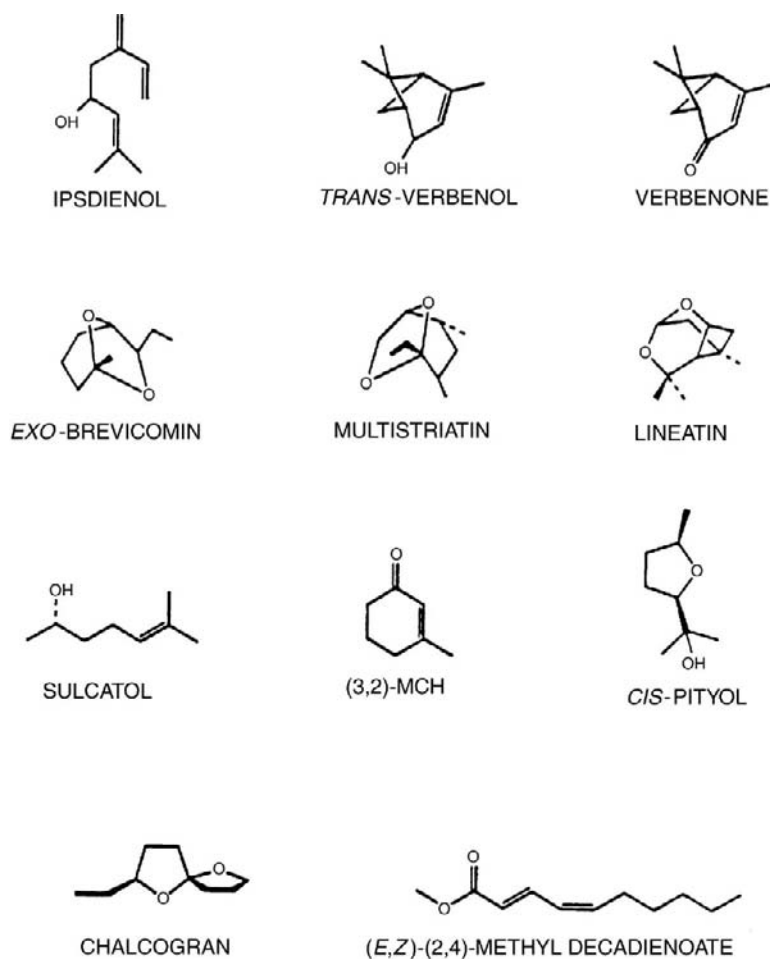
### 1. Attraction

Chemical, visual and acoustic signaling are used to attract potential mates. Attraction of mates can be accomplished by either sex in Coleoptera, but only female Lepidoptera release sex pheromones, and only male Orthoptera stridulate.

Sex pheromones greatly improve the efficiency with which insects find potential mates over long distances in heterogeneous environments (Cardé 1996, Law and Regnier 1971, Mustaparta 1984). Pheromones are typically complex blends of compounds that may or may not be attractive to potential mates when present in ratios that are different from that produced by the “calling” sex (e.g., McElfresh et al. 2001). The particular blend of compounds and their enantiomers, as well as the time of calling, varies considerably among species. These mechanisms represent the first step in maintaining reproductive isolation (McElfresh and Millar 2001). For example, among tortricids in eastern North America, *Archips mortuanus* uses a 90:10 blend of (Z)-11- and (E)-11-tetradecenyl acetate, *Archips argyrospilus* uses a 60:40 blend and *Archips cervasivoranus* uses a 30:70 blend. A related species, *Argyrotaenia velutinana* also uses a 90:10 blend but is repelled by the (Z)-9-tetradecenyl acetate that is incorporated by *A. mortuanus* (Cardé and Baker 1984). Among three species of saturniids in South Carolina, *Callosamia promethea* calls about 10:00–16:00, *C. securifera* about 16:00–19:00, and *C. angulifera* about 19:00–24:00 (Cardé and Baker 1984). Bark beetle pheromones have been studied extensively (e.g., Raffa et al. 1993). Representative bark beetle pheromones are shown in Fig. 4.2.

The evolution of male response to the pheromone blends which are emitted by females apparently is constrained by a trade-off between breadth of response and sensitivity (Hemmann et al. 2008). Males which respond over a wide variation in pheromone composition likely fail to encounter conspecific females. Hence, selection should favor males with narrow response range, but high sensitivity. Hemmann et al. (2008) demonstrated, using a mutant pheromone strain of *Trichoplusia ni*, that hybrid males had the narrow breadth of wild males, but the low sensitivity of mutant males, suggesting a hybrid disadvantage and a mechanism for reinforcement of male pheromone response traits. Groot et al. (2006) reported that ten times more male *Heliothis virescens* were attracted to female *Heliothis subflexa* with introgressed quantitative trait locus from *Heliothis virescens* (that decreased the amount of acetate esters in pheromone glands) than to normal *H. subflexa* females. Hybrid infertility resulting from *H. virescens*/*H. subflexa* mating drove a strong directional selection for higher acetate ester concentrations in female *H. subflexa* pheromone.

Sex pheromones may be released passively, as in the feces of bark beetles (Raffa et al. 1993), or actively through extrusion of scent glands and calling behavior (Cardé and

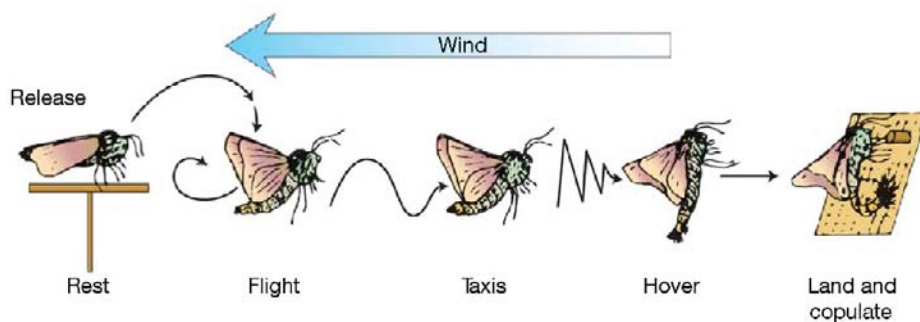


**FIG. 4.2** Representative pheromones produced by bark beetles. Pheromones directly converted from plant compounds include ipsdienol (from mycene), trans-verbenol, and verbenone (from  $\alpha$ -pinene). The other pheromones shown are presumed to be synthesized by the beetles. From Raffa et al. (1993).

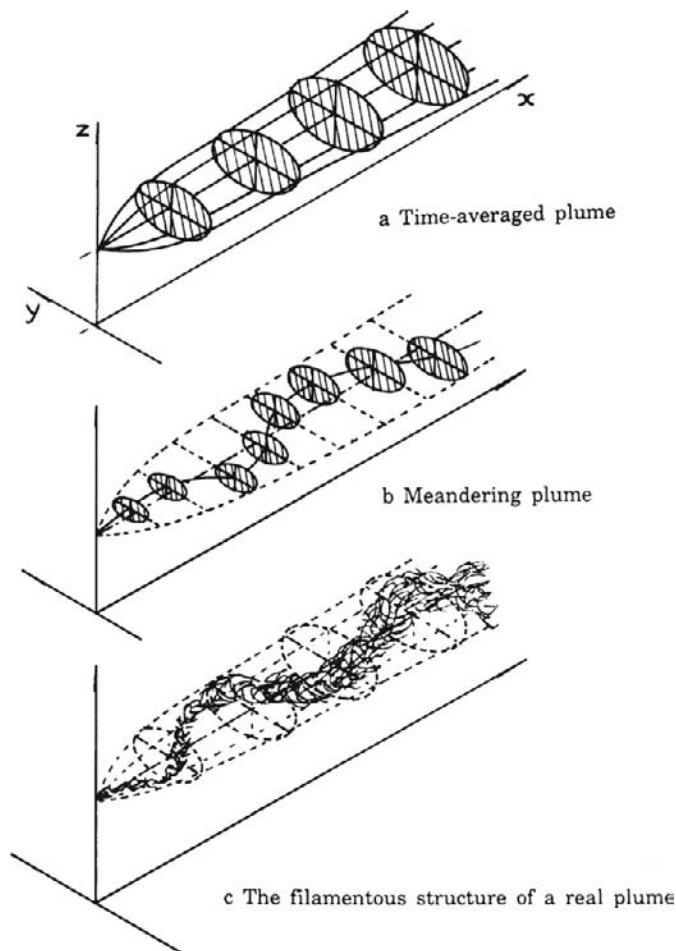
Baker 1984). The attracted sex locates the signaler by following the concentration gradient (Fig. 4.3). Early studies suggested that the odor from a point source diffuses in a cone-shaped plume that expands downwind, with its shape depending on airspeed and vegetation structure (e.g., Matthews and Matthews 2010). However, research by Cardé (1996), Mafra-Neto and Cardé (1995), Murlis et al. (1992) and Roelofs (1995) indicated that this plume is neither straight nor homogeneous over long distances, but is influenced by turbulence in the airstream that forms pockets of higher concentration or absence of the vapor (Fig. 4.4). An insect situated downwind would detect the plume as odor bursts rather than as a constant stream. Heterogeneity in vapor concentration is augmented by pulsed emission by many insects.

Pulses in emission and reception may facilitate orientation, because the antennal receptors require intermittent stimulation to avoid saturation and sustain upwind flight (Roelofs 1995). However, Cardé (1996) noted that the heterogeneous nature of the pheromone plume may make direct upwind orientation difficult over long distances. Pockets of little or no odor may cause the attracted insect to lose the odor trail. Detection can be inhibited





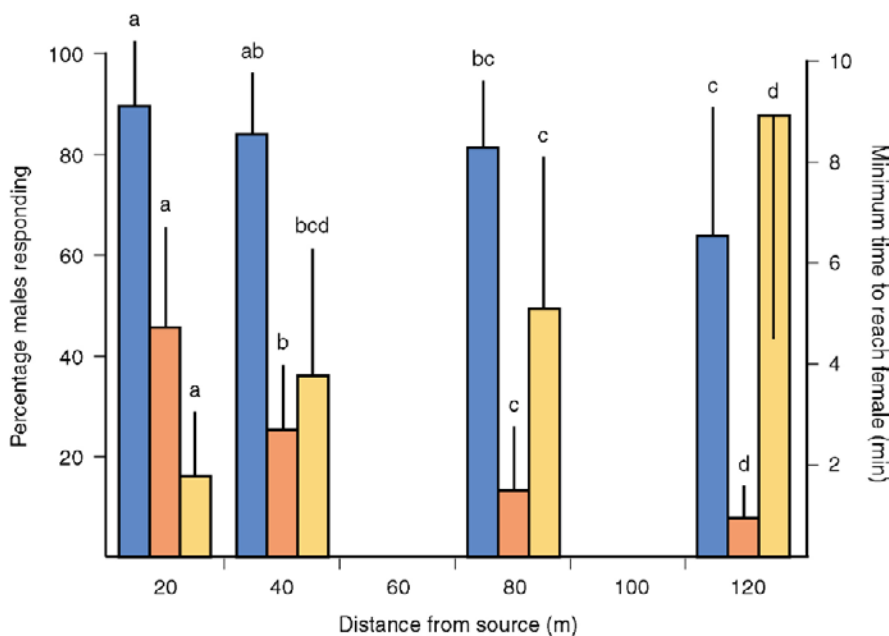
**FIG. 4.3** Typical responses of male noctuid moths to the sex pheromone released by female moths. From Tumlinson and Teal (1987).



**FIG. 4.4** Models of pheromone diffusion from a point source. The time-averaged Gaussian plume model (a) depicts symmetrical expansion of a plume from the point of emission. The meandering plume model (b) depicts concentration in each disc distributed normally around a meandering center line. The most recent work has demonstrated that pheromone plumes have a highly filamentous structure (c). From Murlis et al. (1992) with permission from the Annual Review of Entomology, Vol. 37, © 1992 by Annual Reviews.

further by openings in the vegetation canopy that create warmer convection zones or “chimneys”, which carry the pheromone through the canopy (Fares et al. 1980). Attracted insects may increase their chances of finding the plume again by casting, i.e., sweeping back and forth in an arcing pattern until the plume is contacted again (Cardé 1996). Given the small size of most insects and limited quantities of pheromones for release, mates must be able to respond to very low concentrations. Release of less than  $1 \mu\text{g sec}^{-1}$  by female gypsy moth, *Lymantria dispar*, or silkworm, *Bombyx mori*, can attract males, which respond at molecular concentrations as low as  $100 \text{ molecules ml}^{-1}$  of air (Harborne 1994). Nevertheless, the likelihood of attracted insects reaching a mate is small. Elkinton et al. (1987) reported that the proportion of male gypsy moths responding to a caged female declined from 89% at 20 m distance to 65% at 120 m. Of those males that responded, the proportion arriving at the female’s cage declined from 45% at 20 m to 8% at 120 m, and the average minimum time to reach the female increased from 1.7 min at 20 m to 8.9 min at 120 m (Fig. 4.5). Therefore, the probability of successful attraction of mates is low, and exposure to predators or other mortality factors relatively high, over modest distances.

Visual signaling is exemplified by the fireflies (Coleoptera: Lampyridae) (e.g., Fu et al. 2005, Lloyd 1983). In this group of insects, different species distinguish each other by variation in the rhythm of flashing, and by the perceived “shape” of the flashes that are produced by distinctive movements while flashing. Other insects, including glowworms (Coleoptera: Phengodidae) and several midges, also attract mates by producing luminescent signals.



**FIG. 4.5** Effect of distance on insect perception of, and arrival at, a pheromone source. Proportion (mean  $\pm$  SD) of male gypsy moths responding at 20, 40, 80 and 120 m from a pheromone source (blue bar), mean proportion of those responding that reached the source within a 40 minute period (red bar), and the average minimum time to reach the source (yellow bar);  $n=23$ . Values followed by the same letter do not differ significantly at  $P < 0.05$ . Data from Elkinton et al. (1987).

Acoustic signaling is produced by stridulation, particularly in the Orthoptera, Hemiptera and Coleoptera, or by muscular vibration of a membrane, common in the Hemiptera. Resulting sounds can be quite loud and detectable over considerable distances. For example, the acoustic signals of mole crickets, *Gryllotalpa vinae*, amplified by the double horn configuration of the cricket's burrow, are detectable by humans up to 600 meters away (Matthews and Matthews 2010).

During stridulation, one body part, the file (consisting of a series of teeth or pegs), is rubbed over an opposing body part, the scraper. Generally, these structures occur on the wings and legs (R. Chapman 1982), but in some Hymenoptera, sound also is produced by the friction between abdominal segments as the abdomen is extended and retracted. The frictional sound so produced can be modulated by various types of resonating systems. The frequency and pattern of sound pulses are species specific.

Sound produced by vibrating membranes (tymbals) is accomplished by contracting the tymbal muscle to produce one sound pulse and relaxing the muscle to produce another. Muscle contraction is so rapid (170–480 contractions  $s^{-1}$ ) that the sound appears to be continuous (Matthews and Matthews 2010). The intensity of the sound is modified by air sacs operated like a bellows, and by opening and closing opercula that cover the sound organs (R. Chapman 1982).

Such mechanisms greatly increase the probability of attracting mates. However, many predators also are attracted to, or imitate, the signals of their prey. For example, some firefly species that prey on other fireflies imitate the flash pattern of prey species (Lloyd 1983).

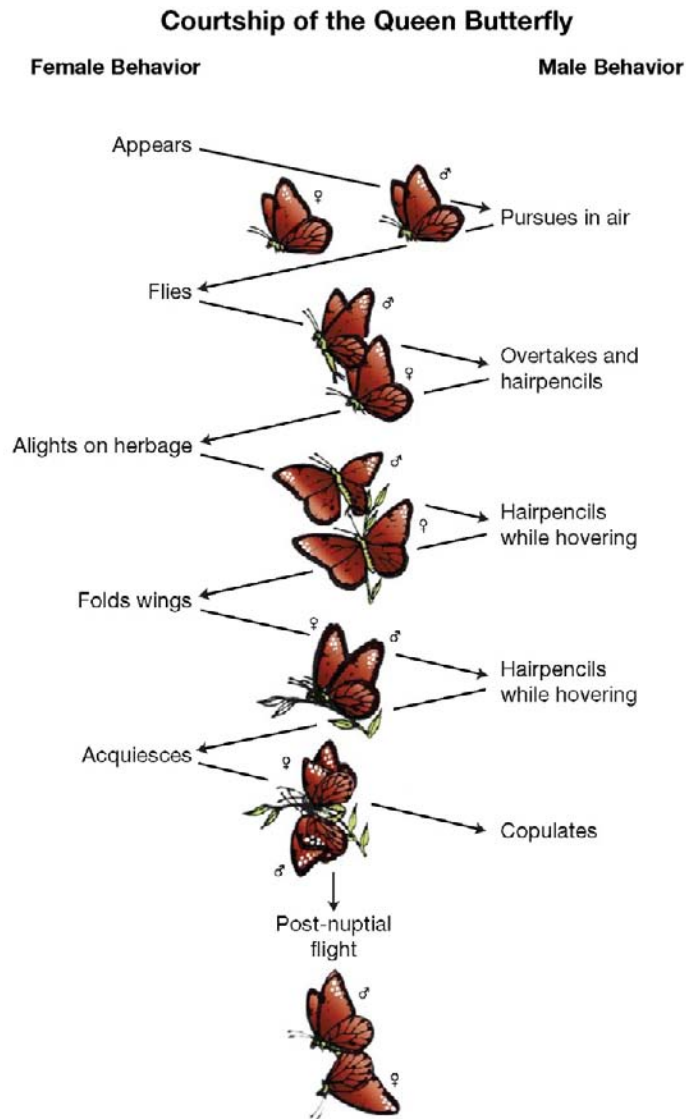
## 2. Courtship Behavior

Courtship often involves an elaborate, highly ritualized sequence of stimulus and response actions that must be completed before copulation occurs (Fig. 4.6). This provides an important mechanism that identifies species and sex, thereby enhancing reproductive isolation. Color patterns, odors and tactile stimuli are important aspects of courtship. For many species, ultraviolet patterns are revealed, close-range pheromones are emitted, or legs or mouthparts stroke the mate as necessary stimuli (L. Brower et al. 1965, Matthews and Matthews 2010).

Another important function of courtship displays in predatory insects is appeasement, or inhibition of predatory responses, especially of females. Nuptial feeding occurs in several insect groups, particularly the Mecoptera, empidid flies, and some Hymenoptera and Hemiptera (Fig. 4.7). The male provides a food gift (such as a prey item, nectar, seed or glandular product) that serves at least two functions (Matthews and Matthews 2010, Price 1997, Thornhill 1976). Males with food may be more conspicuous to females, and feeding the female prior to oviposition may increase fecundity and fitness. Nuptial feeding has become ritualistic in some insects. Instead of prey, some flies simply offer a silk packet.

Conner et al. (2000) reported that male arctiid moths, *Cosmosoma myradora*, acquire pyrrolizidine alkaloids from excremental fluids of some plants, such as *Eupatorium capillifolium*. The alkaloids are incorporated into cuticular filaments that are stored in abdominal pouches and discharged on the female during courtship. This topical application makes the female distasteful to spiders. Alkaloid-deprived males do not provide this protection, and females mated with such males are suitable prey for spiders.

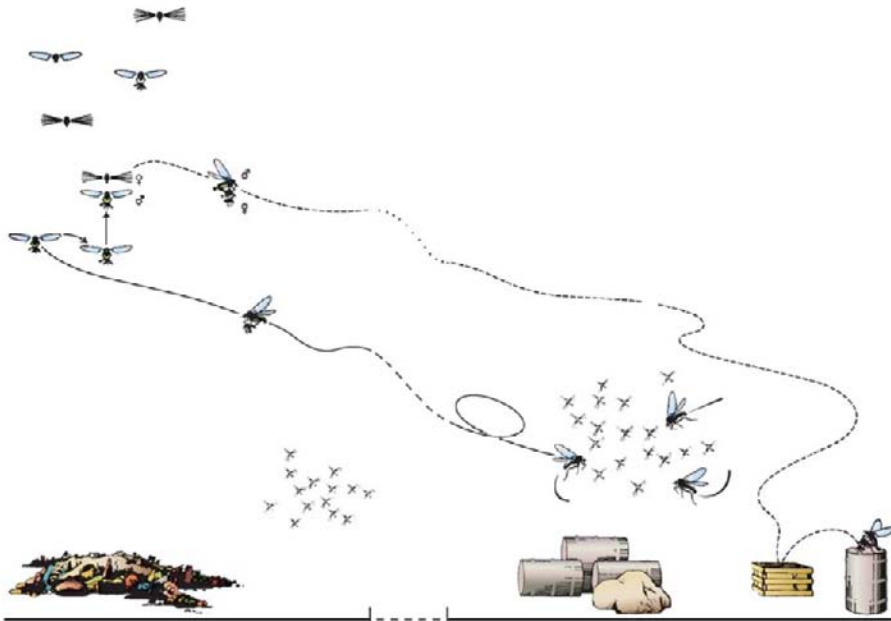
The males of some flies, euglossine bees, Asian fireflies, and some dragonflies gather in groups, called leks, to attract and court females (Fig. 4.7). Such aggregations allow females to compare and choose among potential mates, and hence facilitate mate selection.



**FIG. 4.6** Courtship stimulus–response sequence of the Queen butterfly from top to bottom, with male behavior on the right and female behavior on the left. From L. Brower et al. (1965) with permission from the Wildlife Conservation Society.

### C. Reproductive and Social Behavior

Insects, like other organisms, invest much of their assimilated energy and nutrient resources in the production of offspring. Reproductive behavior includes varying degrees of parental investment, which determines the survival of eggs and juveniles. Selection of suitable sites for oviposition affects the exposure of eggs to abiotic conditions that are suitable for hatching. The choice of oviposition site also affects the exposure of hatching immatures to predators and parasites, and their proximity to suitable food resources. Nesting behavior, brood care, and sociality represent stages in a gradient of parental investment in survival of offspring.



**FIG. 4.7** Example of lekking and appeasement behavior in the courtship of an empidid fly, *Rhamphomyia nigripes*. Males capture a small insect, such as a mosquito or midge, then fly to a mating swarm (lek) which attracts females. Females select their mates and obtain the food offering. The pair then leaves the swarm and completes copulation on nearby vegetation. From Downes (1970) with permission from the Entomological Society of Canada.

### 1. Oviposition Behavior

Insects deposit their eggs in a variety of ways. Most commonly, the female is solely responsible for selection of oviposition site(s). The behaviors leading to oviposition are as complex as those leading to mating, because successful oviposition contributes to individual fitness and is under strong selective pressure.

A diversity of stimuli affects the choice of oviposition sites by female insects. Mosquitoes are attracted to water by the presence of vegetation and reflected light, but lay eggs only if salt content, pH, or other factors sensed through tarsal sensillae, are suitable (Matthews and Matthews 2010). Grasshoppers assess the texture, salinity, and moisture of soil selected for oviposition.

Many phytophagous insects assess the suitability of a host for the development of their offspring. This assessment may be on the basis of host chemistry or existing feeding pressure. Ovipositing insects tend to avoid host materials with deleterious levels of secondary chemicals. Insects also may avoid ovipositing on resources that are already occupied by eggs or by competitors. For example, female bean weevils, *Callosobruchus maculatus*, assess each potential host bean by comparing it to the previous bean, and lay an egg only if the present bean is larger or has fewer eggs. The resulting pattern of oviposition nearly doubles larval survival when compared to random oviposition (R. Mitchell 1975). Many parasitic wasps mark hosts in which eggs have been deposited and avoid ovipositing in marked hosts, thereby minimizing larval competition within a host (Godfray 1994). Parasitic wasps can minimize hyperparasitism by not ovipositing in more than one host in an aggregation. This reduces the risk that all of its offspring are found and parasitized (Bell 1990). Cannibalistic

species, such as *Heliconius* butterflies, may avoid laying eggs near each other, in order to minimize cannibalism and predation.

Selection also determines whether insects lay all their eggs during one period (semelparity) or produce eggs over more protracted periods (iteroparity). Most insects with short life cycles (e.g., < 1 yr) typically have relatively short adult life spans and lay all their eggs in a relatively brief period. Insects with longer life spans, especially social insects, reproduce continually for many years.

Some insects influence host suitability for their offspring. For example, female sawflies typically sever the resin ducts at the base of a conifer needle prior to laying eggs in slits cut distally to the severed ducts. This behavior prevents or reduces the egg mortality that would result from resin flow into the oviposition slits (McCullough and Wagner 1993). Parasitic Hymenoptera often inject mutualistic viruses into the host along with their eggs. The virus inhibits cellular encapsulation of the egg or larva by the host (Tanada and Kaya 1993).

In other cases, choices of oviposition sites by adults clearly conflict with the suitability of resources for offspring. Kogan (1975) and Courtney (1985, 1986) reported that some species preferentially oviposit on the most conspicuous (apparent) host species, which are relatively unsuitable for larval development (Fig. 3.12). However, this behavior represents a trade-off between the prohibitive search time that would be required to find the most suitable hosts and the reduced larval survival on the more easily discovered hosts.

## 2. Nesting and Brood Care

Although brood care is best known among the social insects, others exhibit maternal care of offspring, and even maternal tailoring of habitat conditions to enhance their survival. Primitive social behavior appears as parental involvement extends further through the development of their offspring.

Several environmental factors can facilitate the evolution of parental care (E. Wilson 1975). A stable environment favors larger, longer-lived species that reproduce at intervals, rather than all at once. Establishment in new, physically stressful environments may select for the protection of offspring, at least during vulnerable periods. Intense predation may favor species that guard their young, and so improve their chances of reaching breeding age. Finally, selection may favor species that invest in their young, which, in turn, help the parent find, exploit or guard food resources. Cooperative brood care, involving reciprocal communication among many adults, is the basis of social organization (E. Wilson 1975, see Chapter 5).

A variety of insect species from several orders exhibit protection of eggs by a parent (Matthews and Matthews 2010). In most cases, the female remains near her eggs and guards them against predators. However, in some species of giant water bugs (*Belostoma* and *Abedus*), the eggs are laid on the back of the male, which carries them until they hatch. Among dung beetles (Scarabaeidae), the adults of some species limit their investment in offspring to providing protected dung balls in which the eggs are laid, whereas females in the genus *Copris* remain with the young until they reach adulthood.

Extended maternal care, including provision of food for offspring, is seen in crickets, cockroaches, some Hemiptera and Coleoptera, and non-social Hymenoptera. Maternal care can substantially increase growth and survival of offspring (A. Eggert et al. 1998). For example, females of the membracid, *Umbonia crassicornis*, enhance the survival of their offspring by brooding eggs, cutting slits in the bark of twigs to facilitate feeding by nymphs, and defending nymphs against predators (T.K. Wood 1976). Survival of nymphs with their

mother present was 80%, compared to 60% when the mother was removed 2–3 days after egg hatch, and 10% when the mother was removed prior to making bark slits. Females responded to predators or to alarm pheromones from injured offspring by fanning wings and buzzing, which typically drove the predator away (T.K. Wood 1976).

A number of arthropod species are characterized by aggregations of individuals. Groups can benefit their members in a number of ways. Large groups often are able to modify environmental conditions, such as through retention of body heat or moisture. Aggregations also increase the availability of potential mates (Matthews and Matthews 2010) and minimize the exposure of individuals to plant toxins (McCullough and Wagner 1993, Nebeker et al. 1993), and to predators (Fitzgerald 1995). Aggregated, cooperative feeding on plants, such as by sawflies or bark beetles, can remove plant tissues or kill the plant before induced defenses become effective (McCullough and Wagner 1993, Nebeker et al. 1993). Groups limit the ability of a predator to avoid detection and to separate an individual to attack from within a fluid group. Predators are more vulnerable to injury by surrounding individuals, compared to attack on isolated individuals.

Cooperative behavior is evident within groups of some spiders and communal herbivores, such as tent-building caterpillars and gregarious sawflies. Dozens of individuals of the spider, *Mallos gragalis*, cooperate in construction of a communal web and in subduing prey (Matthews and Matthews 2010). Tent-building caterpillars cooperatively construct their web, which affords protection from predators, and may facilitate feeding and retention of heat and moisture (Fitzgerald 1995). Similarly, gregarious sawflies cooperatively defend against predators and distribute plant resin among many individuals, thereby limiting the effectiveness of the resin defense (McCullough and Wagner 1993).

Primitive social behavior is exhibited by the wood cockroach, *Cryptocercus punctulatus*, by passalid beetles, and by many Hymenoptera. In these species, the young remain with the parents in a family nest for long periods of time, are fed by the parents, and assist in nest maintenance (Matthews and Matthews 2010). However, these insects do not exhibit coordinated behavior or division of labor among distinct castes.

The complex eusociality that characterizes termites and the social Hymenoptera has attracted considerable attention (e.g., Matthews and Matthews 2010, E. Wilson 1975). Eusociality is characterized by the involvement of multiple adult generations and by highly integrated cooperative behavior, with efficient division of labor among all castes (Matthews and Matthews 2010, Michener 1969). Members of these insect societies cooperate in food location and acquisition, in feeding of the immatures, and in defense of the nest. This cooperation is maintained through complex pheromonal communication, including trail and alarm pheromones (Hölldobler 1995, see Chapter 3), and reciprocal exchange of regurgitated liquid foods (trophallaxis) between colony members. Trophallaxis facilitates the recognition of nest mates by maintaining a colony-specific odor, ensures exchange of important nutritional resources and (in the case of termites) of microbial symbionts that digest cellulose, and may be critical to colony survival during periods of food limitation (Matthews and Matthews 2010). Trophallaxis distributes material rapidly throughout a colony (M. Suarez and Thorne 2000). E. Wilson and Eisner (1957) fed honey mixed with radioactive iodide to a single worker ant, and within one day detected some tracer in every colony member, including the two queens. Such behavior also may facilitate spread of pathogens or toxins throughout the colony (J.K. Grace and Su 2001, Shelton and Grace 2003).

In some ant species, capture of slaves from other ant colonies augments or replaces various worker caste functions in the colony. However, some species of slave-making ants, e.g., *Protomognathus americanus*, have little or no effect on the demographics of the ant

species that are exploited as slaves, whereas other slave-making species, e.g., *Leptothorax duloticus*, significantly reduce abundances of queens, workers and larvae of host species (Hare and Alloway 2001).

Development of altruistic behaviors such as social cooperation can be explained largely as a consequence of kin selection and reciprocal cooperation (Axelrod and Hamilton 1981, Haldane 1932, W. Hamilton 1964, Trivers 1971, E. Wilson 1973, Wynne-Edwards 1963, 1965, see also Chapter 15). Self sacrifice that increases reproduction by closely related individuals increases inclusive fitness, i.e., the individual's own fitness plus the fitness accruing to the individual through its contribution to reproduction of relatives. In the case of the eusocial Hymenoptera, because of haploid males, relatedness among siblings is greater than that between a parent and its offspring, making cooperation among colony members highly adaptive. The epitome of "altruism" among insects may be the development of the barbed sting in the worker honey bee that ensures its death in defense of the colony (Haldane 1932, W. Hamilton 1964). Termites do not share the hymenopteran model for sibling relatedness. Genetic data for termites indicates relatively high inbreeding and relatedness within colonies, and kin-biased foraging behavior for some species (Kaib et al. 1996, Vargo et al. 2003). However, Husseneder et al. (1999) reported that DNA analysis of colonies of the African termite, *Schedorhinotermes lamanianus*, did not indicate effective kin selection through inbreeding or translocation complexes of sex-linked chromosomes that could generate higher relatedness within than between sexes. They concluded that ecological factors, such as predation and food availability, may be more important than genetics in maintaining termite eusociality, at least in this species.

Social behavior provides the greatest degree of foraging efficiency, permitting recruitment of multiple individuals to exploit large food resources and to share these resources with nestmates. Furthermore, social behavior allows for division of labor and more efficient performance of the multiple energy-demanding activities, including foraging, reproduction, and defense, typically by means of morphologically-specialized castes.

## D. Competitive, Defensive and Mutualistic Behavior

Insects, like all animals, interact with other species in a variety of ways: as competitors, predators, prey, and mutualists. Interactions among species will be discussed in greater detail in Chapter 8. These interactions require varying degrees of energy and/or nutrient expenditure. Contests among individuals for resources occasionally involve combat. Subduing prey and defending against predators also involve strenuous activity. Mutualism requires reciprocal exchange of resources or services. Obviously, all these activities affect the energy and nutrient budgets of individual organisms.

### 1. Competitive Behavior

Competition occurs among individuals which use the same limiting resources at the same site. Energy that is expended, or injury that is suffered, while defending resources or searching for uncontested resources will affect the fitness of the organism. Competition often is mediated by mechanisms that determine a dominance hierarchy. Establishment of dominant and subordinate status among individuals limits the need for physical combat to determine access to resources and ensures that dominant individuals get more resources than do subordinate individuals.

Visual determination of dominance status is relatively rare among insects, largely because of their small size, the complexity of the environment that they inhabit, which restricts visual



range, and the limitations of fixed-focus compound eyes for long-distance vision (Matthews and Matthews 2010). Dragonflies have well-developed eyes and exhibit ritualized aggressive displays that maintain spacing among individuals. For example, male *Plathemis lydia* have abdomens that are bright silvery-white above. Intrusion of a male into another male's territory initiates a sequence of pursuit and retreat, covering a distance of 8–16 m. The two dragonflies alternate roles and directions, with the abdomens raised during pursuit and lowered during retreat, until the intruder moves to another site (P. Corbet 1962).

Mediation of competition by pheromones has been documented for several groups of insects. Adult flour beetles, *Tribolium*, switch from aggregated distribution at low densities, to random distribution at intermediate densities, to uniform distribution at high densities. This spacing is mediated by the secretion of quinones, which are repellent above a certain concentration, from thoracic and abdominal glands of the beetles (Matthews and Matthews 2010). Larvae of the flour moth, *Anagasta kunniiella*, secrete compounds, from the mandibular glands, which increase dispersal propensity, lengthen generation time and lower the fecundity of females that were crowded as larvae (Matthews and Matthews 2010). Bark beetles employ repellent pheromones, as well as acoustic signals, to maintain minimum distances between individuals boring through the bark of colonized trees (Raffa et al. 1993, Rudinsky and Ryker 1976). Ant colonies also maintain spacing by marking their foraging trails with chemical signals (see above, also Chapter 3).

Acoustic signals are used by many Orthoptera and some Coleoptera to deter competitors. Bark beetles stridulate to deter other colonizing beetles from the vicinity of their gallery entrances (Rudinsky and Ryker 1976). Subsequently, excavating adults and larvae respond to the sounds of approaching excavators by mining in a different direction, thus preventing intersection of their galleries. Some male crickets and grasshoppers produce a distinctive rivalry song when approaching each other (Matthews and Matthews 2010, Schowalter and Whitford 1979). The winner (which will be the continued occupant) typically is the male that produces more of this aggressive stridulation.

When resources are relatively patchy, males may increase their access to females by marking and defending territories that contain resources which are attractive to females. Territorial behavior is less adaptive (i.e., the costs of defending resources exceed the benefits) when resources are highly concentrated and competition is severe, or when resources are uniformly distributed and female distribution is less predictable (Baker 1972, Schowalter and Whitford 1979).

Marking territorial boundaries takes a variety of forms among animal taxa. Male birds mark territories by calling from perches along the perimeter. Male deer rub scent glands and scrape trees with their antlers to advertise their territory. Social insects, including ants, bees, and termites, mark their nest sites and foraging areas with trail pheromones that advertise their presence. These trail markers can be perceived by other insects at minute concentrations (see Chapter 3). Many orthopterans and some coleopterans advertise their territories by stridulating.

However, many insects advertise their presence simply to maintain spacing and do not actively defend territories. Similarly, males of many species, including insects, fight over receptive females. E. Wilson (1975) considered the defense of occupied areas to be the defining criterion for territoriality. Territorial defense is best known among vertebrates, but a variety of insects representing at least eight orders also defend territories against competitors (Matthews and Matthews 2010, Price 1997). Because territorial defense represents an energetic cost, an animal must gain more of the resource by defending it against competitors than by searching for new resources. Non-aggressive males often “cheat” by

non-advertisement and quiet interception of resources or of females attracted to the territory of the advertising male (Schowalter and Whitford 1979).

The type of territory differs among insect taxa, but usually is associated with competition for food or mates (Matthews and Matthews 2010, Price 1997). Male crickets defend the area around their dens and mate with females which are attracted to their stridulation. Male eastern wood cockroaches, *C. punctulatus*, defend mating chambers in rotten wood (Ritter 1964). Some insects that form leks will defend small territories within the lek. Presumably, more females are attracted to this concentration of males, hence increasing mating success, than to isolated males (Price 1997). Such mating territories apparently are not related to food or oviposition sites but may maximize attraction of females.

Two grasshopper species, *Ligurotettix coquilletti* and *Boottettix argentatus*, that feed on the creosotebush, *Larrea tridentata*, in the deserts of southwestern North America, are perhaps the only territorial acridoids (Otte and Joern 1975, Schowalter and Whitford 1979). These grasshoppers defend individual creosotebushes. The larger bushes are more likely to harbor females, and so opportunities for mating are increased by defending larger shrubs, especially at low grasshopper population densities. Schowalter and Whitford (1979) reported that males moved more frequently from small shrubs than from larger shrubs, and contests for larger shrubs occurred more frequently. However, fewer males defended territories at high population densities, apparently because interception of females by non-stridulating males and more frequent combat decreased the mating success of territorial defenders.

Males of the speckled wood butterfly, *Pararge aegeria* (Satyridae), defend sunspots on the forest floor, apparently because females are attracted to resources that occur in sunspots (Price 1997). Only 60% of the males held such territories, but these encountered many more females than did the non-territorial males that searched for mates in the forest canopy. Defense of an oviposition site may be advantageous where sperm competition cannot be avoided by anatomical or physiological means, such as with mating plugs that prevent subsequent mating. Another butterfly, *Inachis io*, defends territories at the approach to oviposition sites, perhaps because of selective pressure from strong competition at the oviposition sites (Baker 1972). Other insects, especially the social Hymenoptera, defend nests, foraging trails, or food (Price 1997).

The benefits of defending food resources or mates must be weighed against the costs of fighting, in terms of time, energy, and risk of injury. Territorial insects may abandon territorial defense at high population densities when time spent fighting detracts from feeding or mating success (Schowalter and Whitford 1979).

## 2. Defensive Behavior

Insects employ a number of strategies to defend themselves against predators. Caddisfly (Trichoptera) larvae construct shelters from benthic debris, but the energy required for construction may limit their survival when organic resources are limited (S. Eggert and Wallace 2003). Mandibulate species frequently bite, and haustellate species may stab with their stylets. Kicking, wing fanning, and buzzing also are effective against some predators (Robinson 1969, T.K. Wood 1976). Many species eject or inject toxic or urticating chemicals, as described in Chapter 3 (Figs. 3.8 and 3.9). Insects armed with urticating spines or setae often increase the effectiveness of this defense by making thrashing body movements that increase contact of the spines or setae with an attacker. Many caterpillars and sawfly larvae rear up and strike like a snake when attacked (Fig. 4.8).



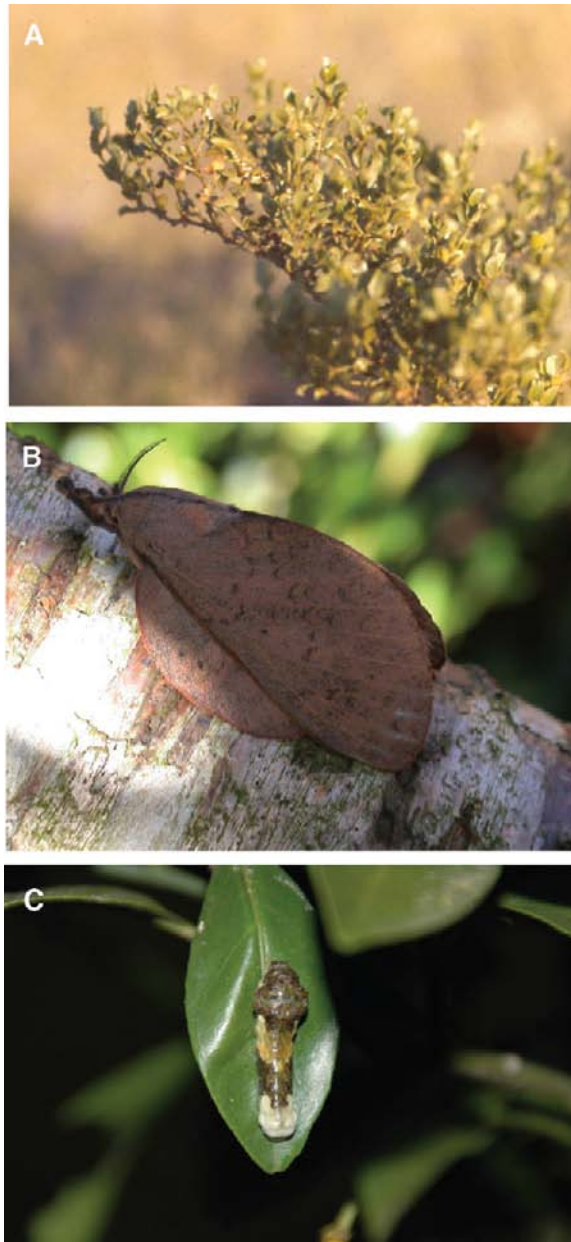
**FIG. 4.8** Defensive posture of black swallowtail, *Papilio polyxenes*, caterpillar. This snake-like posture, together with emission of noxious volatiles from the orange protuberances, deters many would-be predators.

Insects produce a variety of defensive compounds that can deter or injure predators, as described in Chapter 3. Many of these compounds are energetically expensive to produce, and may be toxic to the producer as well as to predators, requiring special mechanisms for storage or delivery. Nevertheless, their production sufficiently improves the probability of survival and reproduction to represent a net benefit to the producer (Conner et al. 2000, Sillén-Tullberg 1985). Such species typically are conspicuously colored (aposematic) to facilitate avoidance learning by predators (Fig. 4.9).



**FIG. 4.9** Examples of aposematic coloration. A) lygaeid seed bugs and B) heliconiid butterflies sequester toxins from their host plants and advertise their distasteful or toxic quality.

Defense that is conferred by camouflage reduces the energy costs of active defense, but this strategy may require greater efficiency in foraging or other activities that affect attraction of predators (Schultz 1983). Insects that rely on resemblance to their background (crypsis) must minimize movement in order to avoid detection (Fig. 4.10). For example, many Hemiptera that are cryptically colored, or that resemble thorns or debris, are largely



**FIG. 4.10** Examples of cryptic coloration. A) Creosotebush grasshopper, *Bootettix argentatus*, in creosotebush, *Larrea tridentata*, (New Mexico, U.S.), B) lasiocampid moth, *Gastropacha pardalis formosana* with leaf-mimicking coloration and form (Taiwan), C) giant swallowtail, *Papilio cresphontes*, larvae imitating bird feces (southern U.S.).

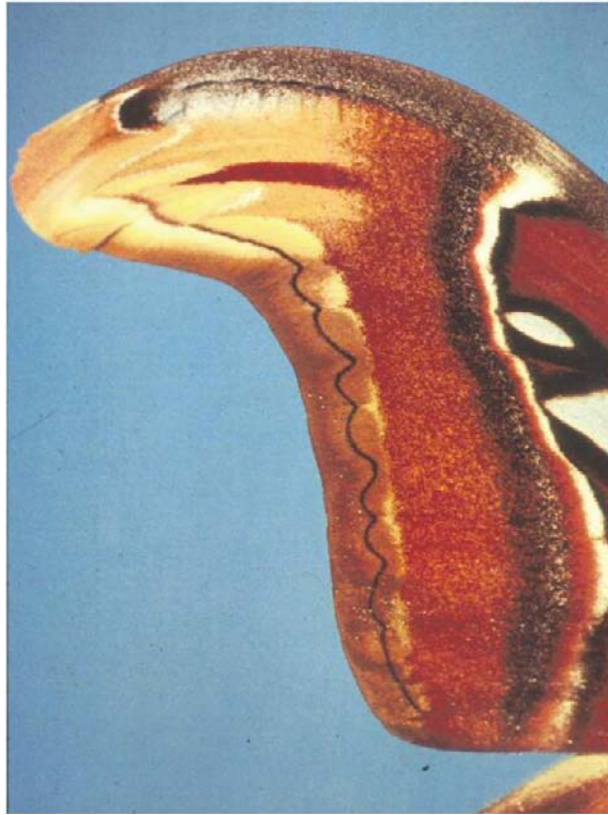
sedentary while siphoning plant fluids. Many aquatic insects resemble benthic debris and remain motionless as they filter suspended matter. Cryptic species typically restrict necessary movement to nighttime or acquire their food with minimal movement, especially in the presence of predators (Johansson 1993). Such insects may escape predators by waiting until a predator is very close before flushing with a startle display, giving the predator insufficient warning to react. However, some birds use tail fanning or other scare tactics to flush prey from a greater distance and thereby capture prey more efficiently (Galatowitsch and Mumme 2004, Jablónsky 1999, Mumme 2002).

Disruptive and deceptive coloration can involve color patterns that break up the body form, distract predators from vital body parts, or make the insect resemble other predators. For example, many insects have distinctive bars of color or other patterns that disrupt the outline of the body and inhibit their identification as prey by passing predators. Startle displays enhance the effect of color patterns (Robinson 1969). The underwing moths (Noctuidae) are noted for their brightly colored hind wings, which are hidden when at rest by the cryptically colored front wings. When threatened, the moth suddenly exposes the hind wings, and so has an opportunity to escape its startled attacker. The giant silkworm moths (Saturniidae) and eyed elater, *Alaus oculatus* (Coleoptera: Elateridae) have conspicuous eyespots that make these insects look like birds (especially owls) or reptiles. The eyespots of moths are typically hidden on the hind wings during rest and can be exposed suddenly to startle would-be predators. The margin of the front wings in some saturniids are shaped and colored to resemble the heads of snakes (Fig. 4.11) (Grant and Miller 1995). Sudden wing movement during escape may enhance the appearance of a striking snake.

Mimicry is the resemblance by one species to another, usually venomous or unpalatable, species and typically involves conspicuous, or aposematic, coloration. Mimicry can take two forms: **Batesian** and **Müllerian**. Batesian mimicry is resemblance of a palatable or innocuous species to a threatening species, whereas Müllerian mimicry is resemblance among threatening species. Some of the best examples of both types occur among insects. A variety of insects (representing several orders) and other arthropods (especially spiders) benefit from their resemblance to stinging Hymenoptera. For example, clearwing moths (Sessidae) and some sphingid moths, several cerambycid beetles and many asilid and syrphid flies resemble bees or wasps (Fig. 4.12). A variety of insect and other species gain protection through adaptations that permit them to mimic ants (Blum 1980, 1981). Müllerian mimicry is exemplified by sympatric species of Hymenoptera and heliconiid butterflies that sting, or are unpalatable, and resemble each other (e.g., A. Brower 1996, P. Sheppard et al. 1985).

Mimicry systems can be complex, including a number of palatable and unpalatable species and variation in palatability among populations, depending on food source. For example, the resemblance of the viceroy, *Limenitis archippus* (Nymphalidae), butterfly to the monarch, *Danaus plexippus* (Daneidae), butterfly is generally considered to be an example of Batesian mimicry. However, monarch butterflies show a spectrum of palatability over their geographic range, depending on the quality of their milkweed, and other, hosts (L. Brower et al. 1968). Furthermore, populations of the viceroy and monarch in Florida are equally distasteful (Ritland and Brower 1991). Therefore, this mimicry system may be Batesian in some locations and Müllerian in others. Conspicuous color patterns and widespread movement of the co-models/mimics maximizes exposure to predators and reinforces predator avoidance, providing overall protection against predation.

Sillén-Tullberg (1985) compared predation by great tits, *Parus major*, between normal aposematic (red) and mutant cryptic (grey) nymphs of the seed bug, *Lygaeus equestris*. Both prey forms were equally distasteful. All prey were presented against a grey background.



**FIG. 4.11** Image of a snake's head on the wing margins of *Attacus atlas*. From Grant and Miller (1995) with permission from the Entomological Society of America.

Survival of aposematic nymphs was 6.4-fold higher than that of cryptic nymphs, because the birds showed a greater initial reluctance to attack, learned avoidance more rapidly, and killed prey less frequently during an attack. The greater individual survival of aposematic nymphs indicated sufficient benefit to explain the evolution of aposematic coloration.

Some insects alert other members of the population to the presence of predators. Alarm pheromones are widespread among insects. These compounds typically are relatively simple hydrocarbons, but more complex terpenoids occur among ants. The venom glands of stinging Hymenoptera frequently include alarm pheromones. Alarm pheromones function either to scatter members of a group when threatened by a predator, or to concentrate attack on the predator, especially among the social insects. A diverse group of ground-dwelling arthropods produce compounds that mimic ant alarm pheromones. These function to scatter attacking ants, allowing the producer to escape (Blum 1980).

### 3. Mutualistic Behavior

Insects participate in a variety of mutualistic interactions, including the well-known pollinator–plant, ant–plant, and wood borer–microorganism associations (see Chapter 8). Typically, mutualism involves diversion of resources by one partner to the production of rewards or inducements that maintain mutualistic interactions. Various pollinators and predators exploit



**FIG. 4.12** Batesian mimicry by two insects. The predaceous asilid fly on the left and its prey, a cerambycid beetle, both display the black and yellow coloration typical of stinging Hymenoptera.

resources allocated by plants to the production of nectar, domatia, root exudates, etc., and thereby contribute substantially to plant fitness. At the same time, the plant limits the nectar reward in each flower to force pollinators to transport pollen among flowers. During dispersal, bark beetles secrete lipids into mycangia to nourish mutualistic microorganisms that subsequently colonize wood and improve the nutritional suitability of woody substrates for the beetles. Obviously, the benefit gained from this association must outweigh these energetic and nutritional costs (see Chapter 8). Resources directed to the support of mutualists could be allocated to growth and reproduction. These resources may be redirected if the partner is not present (e.g., Rickson 1977), although some species maintain such allocation for long periods in the absence of partners (Janzen and Martin 1982).

### III. EFFICIENCY OF RESOURCE USE

Fitness accrues to organisms to the extent that they survive and produce more offspring than do their competitors. Hence, the efficiency with which assimilated resources are allocated to growth and reproduction determines fitness. However, except for sessile organisms, much of the assimilated energy and material must be allocated to activities pursuant to food acquisition, dispersal, mating, competition and defense. The amount of assimilated resources allocated to these activities reduces relative growth efficiency (Schultz

1983, Zera and Denno 1997, Zera and Zhao 2006). Clearly, the diversion of resources from growth and reproduction to these other pathways must represent a net benefit to the insect.

## A. Factors Affecting Efficiency

Efficiency is affected by a number of constraints on energy and resource allocation. Clearly, selection should favor physiological and behavioral adaptations that improve overall efficiency. However, adaptive strategies reflect the current net result of many factors which have variable and interactive effects on survival and reproduction. Hence, individual responses to current conditions vary in efficiency. Whereas physiological, and many behavioral, responses are innate (genetically based, and relatively inflexible), the capacity to learn can improve efficiency greatly, by reducing the time and resources that need to be expended in responding to environmental variation (Cunningham et al. 1998, A. Lewis 1986).

Hairston et al. (1960) stimulated research on the constraints of food quality on efficiency of herbivore use of resources by postulating that all plant material is equally suitable for herbivores. Just as plant chemical defenses can reduce herbivore efficiency, various animal defenses increase the resource expenditure necessary for predators to capture and assimilate prey. In addition to the factors which affect the efficiency of resource acquisition, several factors affect the efficiency of resource allocation, including food quality, size, physiological condition and learning.

### 1. Food Quality

Food quality affects the amount of food required to obtain sufficient nutrition for growth, reproduction, and the energy and nutrients required for detoxification and digestion (see Chapter 3). Insects that feed on hosts with lower levels of defensive compounds invest fewer energy and nutrient resources in detoxification enzymes or continued searching behavior than do insects feeding on better defended hosts. Herbivores process much undigestible plant material, especially cellulose, whereas predators process animal material that generally is consistent with their needs. Accordingly, we might expect higher assimilation efficiencies for predators than for herbivores (G. Turner 1970). Although undigestible and toxic compounds in plant tissues reduce assimilation efficiency for herbivores (Scriber and Slansky 1981), the toxins sequestered or produced by prey also reduce assimilation efficiency of predators. However, few studies have addressed the effect of toxic prey on assimilation efficiency of predators (L. Dyer 1995, Stamp et al. 1997, Stephens and Krebs 1986).

Insects may ingest increased amounts of food to obtain sufficient nutrients or enough energy to offset the costs of detoxification or avoidance of plant defensive chemicals. Among herbivores, species that feed on mature tree leaves have relative growth rates that are generally half the values for species that feed on forbs, because tree leaves are poor food resources compared to forbs (Scriber and Slansky 1981). Although specialists might be expected to feed more efficiently on their hosts than do generalists, Futuyma and Wasserman (1980) reported that one specialist (the eastern tent caterpillar, *Malacosoma americana*) had no greater assimilation or growth efficiencies than did a generalist (the forest tent caterpillar, *Malacosoma disstria*). Some wood boring insects may require long periods (several years to decades) of larval feeding to concentrate nutrients (especially N and P) in quantities sufficient to complete development.



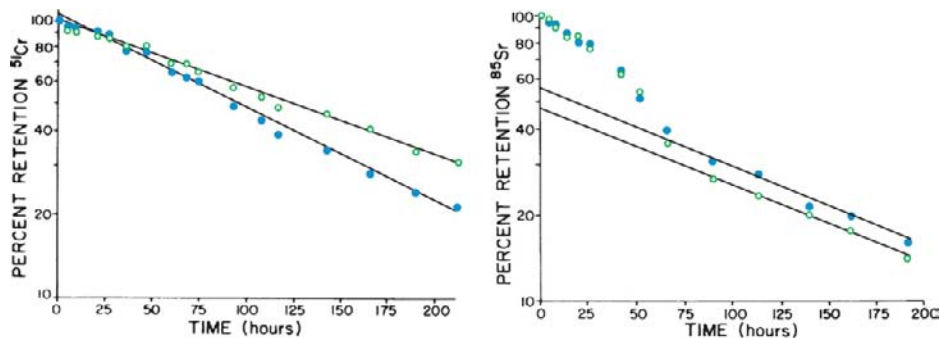
## 2. Size and Physiological Condition

Body size is a major factor that affects the efficiency of energy use. Larger organisms have greater energy requirements than do smaller organisms. However, smaller organisms with larger surface area/volume ratios are more vulnerable to heat loss than are larger organisms. Accordingly, maintenance energy expenditure per unit body mass decreases with increasing body size (Phillipson 1981). In addition, larger organisms tend to use energy more efficiently during movement and resource acquisition, have a competitive advantage in cases of direct aggression, and have greater immunity from predators (Ernsting and van der Werf 1988, Heinrich 1979, Phillipson 1981, Streams 1994), thereby reducing their relative energy expenditures for these activities.

Physiological condition, including the general vigor of the insect as affected by parasites, also influences food requirements and assimilation efficiency. For example, hunger may induce an increased effort to gain resources that would be ignored by less desperate individuals (Ernsting and van der Werf 1988, Holling 1965, Iwasaki 1990, 1991, Richter 1990, Streams 1994). Slansky (1978) reported that cabbage white butterfly larvae that were parasitized by *Apanteles glomeratus* (Hymenoptera) showed increased food consumption, growth rate, and nitrogen assimilation efficiency. Schowalter and Crossley (1982) found that Madagascar hissing cockroaches, *Gromphadorhina portentosa*, with associated mites, *Gromphadorholaelaps schaeferi*, had a significantly more rapid egestion rate than did cockroaches with mites excluded, although assimilation efficiency did not differ significantly between mite-infested and mite-free cockroaches (Fig. 4.13).

## 3. Learning

Learning is a powerful tool for improving efficiency of resource use (see Chapter 3). Learning reduces the effort that is wasted in unsuccessful trials (Fig. 3.16). Learning to distinguish appropriate from inappropriate prey (e.g., search image), to respond to cues associated with earlier success, and to improve foraging technique greatly increases the efficiency of energy and nutrient acquisition (Cunningham et al. 1998, Ishii and Shimada 2010). Learning has been demonstrated by a wide variety of insects, and memory can be



**FIG. 4.13** Bioelimination of  $^{51}\text{Cr}$  (left) and  $^{85}\text{Sr}$  (right) by the cockroach, *Gromphadorhina portentosa* with (solid circles) and without (open circles) the associated mite, *Gromphadorholaelaps schaeferi*.  $^{51}\text{Cr}$  has no biological function and its elimination represents egestion;  $^{85}\text{Sr}$  is an analogue of Ca and its elimination represents both egestion (regression lines similar to those for  $^{51}\text{Cr}$ ) and excretion of assimilated isotope (rapid initial loss). This insect appears to assimilate and begin excreting nutrients before gut passage of unassimilated nutrients is complete. From Schowalter and Crossley (1982) with permission from the Entomological Society of America.

retained throughout metamorphosis in holometabolous insects (R. Davis 2005, Dukas 2008, Gutiérrez-Ibáñez et al. 2007, Kawecki 2010, see Chapter 3). Honey bees represent the epitome of resource utilization efficiency among insects through their ability to communicate foraging success and the location of nectar resources to nestmates (F. Dyer 2002, J. Gould and Towne 1988, Heinrich 1979, von Frisch 1967).

## B. Trade-offs

Allocation efficiency often is optimized by adaptations that generally tailor insect morphology, life histories or behavior to prevailing environmental conditions or resource availability. For example, synchronization of life histories with periods of suitable climatic conditions and food availability reduces the energy that is required for thermoregulation or search activity. The anatomy of the bumble bee, *Bombus* spp., optimizes heat retention during foraging in cool temperate and arctic habitats (Heinrich 1979). Davison (1987) compared the energetics of two harvester ant species, *Chelaner rothsteini* and *Chelaner whitei*, in Australia and found that the smaller *C. rothsteini* had lower assimilation efficiency, but higher production efficiency (largely in production of offspring) than did the larger *C. whitei*. *Chelaner rothsteini* discontinued activity during the winter, perhaps to avoid excessive metabolic heat loss, whereas *C. whitei* remained active all year. Zera and Zhao (2006) found that flight-capable morphs of the cricket, *G. firmus*, converted ingested glycine into triglycerides to fuel flight, at the expense of use in reproduction, whereas flight-incapable morphs incorporated glycine into ovarian protein and reproduction, at the expense of wing development and flight.

Selection should favor those individuals and species that acquire and allocate resources most efficiently. Courtship behavior is under genetic control (e.g., Demir and Dickson 2005) and selected by environmental factors. The males that defend territories, when the time or energy spent on this activity interferes with mating and reproduction, are less likely to contribute to the genetic composition of the next generation than are those males that sacrifice territorial defense for mating opportunities under such conditions (Schowalter and Whitford 1979).

However, as discussed above and in Chapter 3, many allocation pathways compete for assimilated resources. The production of defenses by plants reflects trade-offs between growth and wound repair. Similarly, insects face trade-offs in energy and nutrient allocation to various activities that interact to determine fitness. Predator avoidance behavior reduces time spent feeding (Folz et al. 2006, M.T. Johnson et al. 2006). Matsuda et al. (1993) modeled the effects of multiple predators on anti-predator defenses and concluded that increasing defense against one predator comes at the expense of defenses against another. Hence, conflicts among metabolic pathways, strategies or life stages can often reduce the overall efficiency of resource use. Resource allocation by insects, as well as other organisms, reflects trade-offs among alternative strategies, even between life stages.

Trade-offs occur among steps in resource acquisition. Leaf fragments collected by leaf-cutting ants, *Atta columbica*, were smaller than predicted for maximum foraging efficiency (Burd and Howard 2005). By examining leaf processing within ant nests, Burd and Howard (2005) found that the time required for below-ground processing greatly exceeded the time that was needed to move leaf fragments from the vegetation source, and that leaf fragment size strongly affected the time required for below-ground processing. Thus, selection for smaller loads by foragers may have evolved to optimize the below-ground time needed for processing leaf fragments.

Heinrich (1979) evaluated the trade-offs among various allocation strategies seen among bees. Some bee species begin producing queens and drones (offspring) concurrent with colony development (i.e., production of combs and workers), whereas other bee species achieve large colony sizes before producing queens and drones. The first strategy yields immediate, but small, returns because of the competing activities of workers, and the second strategy yields no immediate returns, but the eventual return is much larger. In addition, workers must weigh the cost of foraging from particular flowers against the expected nectar returns, especially at low temperatures when nectar return must be at least sufficient to maintain the high thoracic temperatures necessary for continued foraging. Because different flowers provide different amounts of nectar, bees tend to forage at flowers with high yields over a range of temperatures, but visit flowers with small nectar rewards only at high temperatures. Similarly, bees must weigh the benefits of foraging at various distances from the colony. Bees will fly several kilometers, given adequate floral rewards, but respond quickly to indications of declining nectar availability, e.g., they will leave an inflorescence or patch after encountering empty flowers.

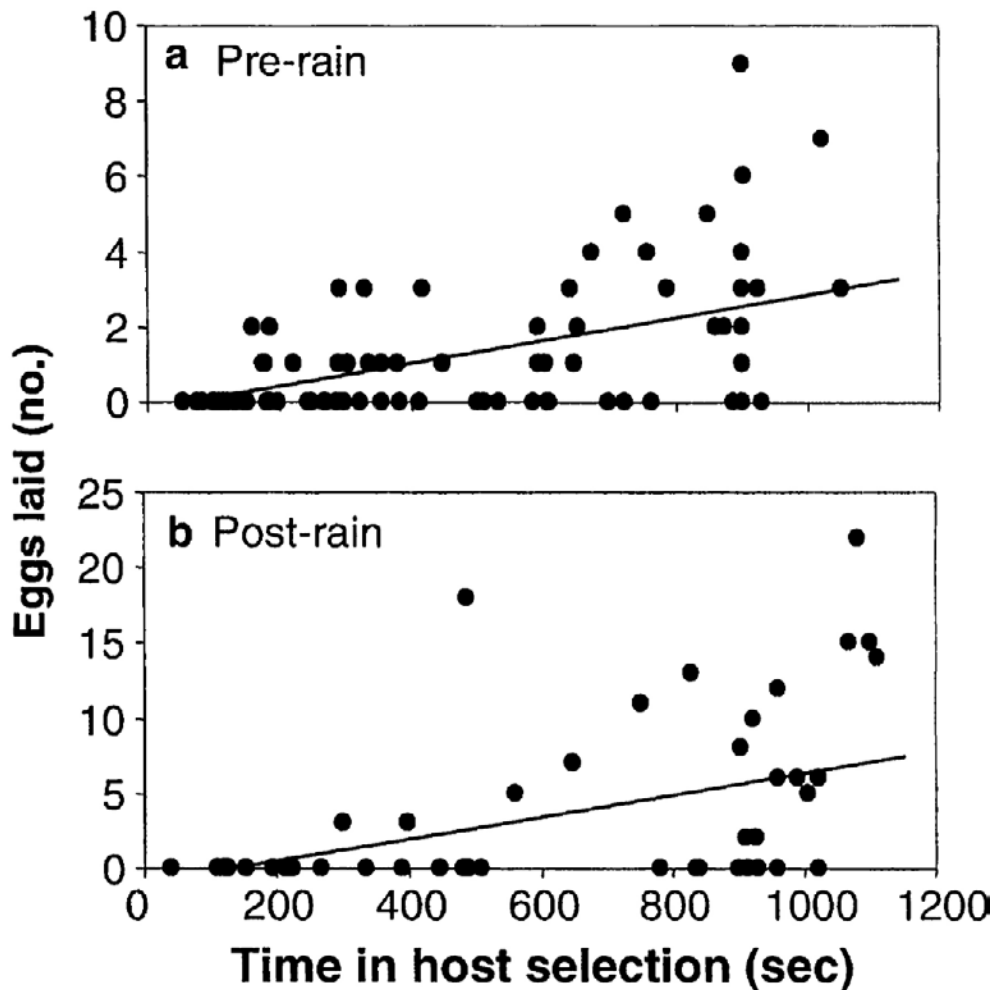
Even learning, which increases the efficiency of performing learned tasks, has measurable fitness costs (Kawecki 2010). Mery and Kawecki (2005) demonstrated that *Drosophila melanogaster* that were conditioned to form long-term memory through associative learning died earlier when deprived of food and water than did flies subjected to other conditioning treatments. Burger et al. (2008) found that females conditioned to form long-term memory showed a 15% shorter lifespan and a faster decline in fecundity with age, compared to control flies. Furthermore, flies which were experimentally selected for delayed aging showed poor ability to learn, compared to control populations. These studies clearly indicated significant fitness costs for formation and maintenance of long-term memory. Predators learning to focus on the search image of the most frequently-encountered cryptic prey can improve detection and efficiency of foraging on more common prey, but may overlook less common prey types that do not match the search image (Ishii and Shimada 2010).

Heterogeneous habitats force many herbivores and predators to expend energy searching for scattered resources. Many individuals will be unable to maintain energy or nutrient balance under such conditions. Huberty and Denno (2006) compared differences in flight and feeding capability in two wing-dimorphic phloem-feeding planthoppers to evaluate trade-offs between ingestion and dispersal capability. The more sedentary *Prokelisia dolus* allocates more resources to feeding, whereas *Prokelisia marginata* allocates more resources to flight. Brachipterous forms of both species invest more energy in feeding musculature and less in flight than do the macropterous forms. As a result, *P. dolus* is better adapted to increase ingestion, in order to deal with deteriorating host quality, than is *P. marginata*, which must disperse to find more suitable hosts. By contrast, abundant, suitable resources reduce the costs of searching for, or detoxifying, resources and facilitate maintenance of energy and nutrient budgets. Frequent encounters with predators, especially when combined with low availability of food resources, may restrict the time an individual can spend foraging and increase the expenditure of energy to avoid predators, thus lowering net energy acquisition and potentially leading to an energy balance that is inadequate for survival.

Several studies have demonstrated the trade-offs between life stages. Female pierid butterflies oviposited preferentially on more conspicuous hosts, a more energetically-efficient search strategy for the adult, but these hosts were less suitable for larval development than were less conspicuous hosts (Fig. 3.12) (Courtney 1985, 1986). Similarly, females of the noctuid moth, *Autographa precationis*, preferentially oviposit on soybeans, rather than on dandelions, perhaps because the shape of dandelions is a less effective oviposition stimulus, although larvae show a marked feeding preference for dandelions (Kogan 1975).

Hoekman et al. (2007) reported that female pitcher-plant mosquitoes, *Wyeomyia smithii*, showed higher oviposition rates in pitcher plant, *Sarracenia purpurea*, leaves with low levels of experimental enrichment (0 or 2 dead ants), compared to a high rate of enrichment (20 dead ants), whereas larval development was higher at the high rate of enrichment.

Survival of individuals and species represents the net result of various traits that often conflict (Carrière et al. 1997). Environmental changes, especially rapid changes which occur as a result of anthropogenic activities, will change the balance among these trade-offs, thereby affecting fitness in various ways. Papaj et al. (2007) reported that the rates at which female pipevine swallowtails, *Battus philenor*, discovered their host plants, *Aristolochia watsoni*, declined following summer monsoon rains in Arizona, due to the difficulty of finding hosts amid the flush of non-host vegetation, but that rates at which eggs were laid on hosts increased (Fig. 4.14). These results indicated that oviposition was limited more by



**FIG. 4.14** Relationship between total number of eggs laid in an observation period and time engaged in host selection for pipevine swallowtail females a) prior to onset of monsoon rains ( $n=86$ ) and b) after subsidence of monsoon rains ( $n=52$ ). Lines indicate fit to ANCOVA model. Note different scales on y axes of the two plots. From Papaj et al. (2007) with kind permission from the authors and Springer Science + Business Media.

low host quality before the summer monsoon than by the low rate of host discovery after the monsoon, suggesting that the predicted increase in droughts for this region will reduce reproduction by this species. Warmer global temperatures may improve energy balance for some arctic species, but will increase respiration losses, or time spent seeking shade for other species. Ecosystem fragmentation will require greater energy expenditure for sufficient foraging and dispersal, thereby impeding movement of intolerant species over inhospitable landscapes. Some species will benefit from changes that improve overall performance (e.g., survival and reproduction), whereas other species will decline or disappear.

#### IV. SUMMARY

Acquired resources are allocated to various pathways. First, they either are assimilated or egested. Assimilated resources either are allocated to production or are expended, e.g., through respiration. Consumption and allocation of resources are influenced by insect size, maturity, food quality, and parasitism. Fitness accrues to the extent that assimilated resources are used for growth and reproduction. However, insect allocation patterns represent trade-offs among competing requirements of growth, reproduction, and the range of activities that are necessary for food acquisition, mating, reproduction, and interactions with other organisms.

Species persist to the extent that the benefits of these behaviors outweigh the costs, i.e., survival and reproduction are increased by the investment of energy in particular behavior and associated biochemicals. Foraging and reproductive behaviors should provide the best return for the time and effort that is spent in searching. Reproductive behavior should maximize the survival of offspring. Among insects, selection of appropriate oviposition sites determines egg development and survival. Brood care is well-represented among insects, with examples ranging from protection of young, to provision of food resources, to development of complex social systems for brood care and colony maintenance. However, in some cases, efficiency of adult behaviors may be in conflict with efficiency of juvenile behaviors. For example, adults may oviposit on the most easily found hosts, whereas the survival of the immatures may depend on discovery of more suitable food hosts.

Competition and defense against predators often involve considerable expenditure of resources. In many species, males engage in various forms of combat to decide which may mate successfully. Territorial behavior is characterized by both the marking of territorial boundaries and the defense of the territory against intruders. Defense of territories may maximize access to food or mates at low population densities, but becomes less advantageous and may be abandoned at high population densities. Insects defend themselves against predators both physically and chemically. Behavior often enhances the effectiveness of protective coloration or toxins. For example, cryptically-colored insects typically avoid movement during times when predators are active, whereas other insects may suddenly expose eyespots or brightly colored body parts to startle an attacker. Some insects imitate snakes or other predators through color patterns or movements. Such strategies minimize the energetic cost of physical defense but require greater efficiency in foraging or reproductive movements to avoid detection.

The efficiency of foraging, reproductive, competitive and defensive behavior may be increased by use of visual, chemical or acoustic signals that communicate information to recipients. Insects can improve foraging and mating efficiency by orienting toward chemical cues that are produced by suitable resources or by potential mates. Discovery of a potential mate initiates a courtship ritual that improves fitness by ensuring species

recognition and receptivity. Competition for food or mates can be minimized by signals that deter other individuals.

Environmental changes will affect the efficiency of resource acquisition and allocation strategies. Global warming will improve energy balance for some species (e.g., early season or high latitude pollinators) but may increase respiration costs beyond ability to acquire energy and nutrients for others. Ultimately, insect strategies for acquiring and allocating energy and nutrient resources affect community interactions, energy flow and nutrient cycling processes.

This page intentionally left blank

# POPULATION ECOLOGY

A POPULATION IS A GROUP OF INTERBREEDING MEMBERS of a species, and it represents a fundamental unit of evolution and ecology. Individual fitnesses are integrated at the population level to determine the persistence or extinction of a species. This is the level of ecological organization that is the focus of evolutionary ecology, ecological genetics, biogeography, sampling methodology, pest management, and recovery of endangered species. These disciplines all have contributed enormously to our understanding of population level phenomena.

A number of more or less discrete subpopulations may be distributed over the geographic range of a species population. Movement of individuals among these “demes” (composing a “metapopulation”) and newly available resources compensates for local extinctions resulting from disturbances or biotic interactions (Hanski and Gilpin 1997). Populations are characterized by structural attributes—such as density, dispersion pattern, and age, sex and genetic composition (Chapter 5). These change across time (Chapter 6) and space (Chapter 7), and as a result of responses to changing environmental conditions.

The population structure and dynamics of insects have been the subject of much ecological research. Examination of population structure and process rates can provide clues to invasiveness or conservation status in changing habitats. Population structure also can indicate future population trends. Predicting outbreaks requires an understanding of the relationships between population structure and changes in population size. Rapidly growing populations are typically characterized by a high production of offspring per adult. Some growing populations also show changes in distribution of individuals.

The abundance of many insects can change by several orders of magnitude over very short time scales, because of their small size and rapid reproductive rates. Such rapid and dramatic changes in abundance often occur in response to



---

subtle environmental changes. This facilitates statistical evaluation of population response to environmental factors, making insects useful indicators of environmental change. The reproductive capacity of many insects enables them to colonize new habitats and exploit favorable conditions or new resources quickly. However, their small size, short life span and dependence on chemical communication to find mates at low densities limit the persistence of small or local populations during periods of adverse conditions, frequently leading to local extinction.

Population dynamics reflect the net effects of differences among individuals in their physiological and behavioral interactions with the environment. Changes in individual success in finding and exploiting resources, in mating and reproducing, and in avoiding mortality agents determine the overall numbers of individuals, their spatial distribution, and their genetic composition at any point in time. Population structure is a component of the environment for the members of the population and provides information that affects individual physiology and behavior, hence fitness (see Section I). For example, population density affects competition for food and oviposition sites (as well as other resources), the propensity of individuals to disperse, and the proximity of potential mates.

Population structure and dynamics also affect community structure and ecosystem processes (Sections III and IV). Each population constitutes a part of the environment for the other populations in the community. Changes in the population size of any one species will affect the population(s) on which it feeds and population(s) which prey on, or compete with, it (Chapter 8). Changes in the size of any population also will affect the importance of its ecological functions. A decline in pollinator abundance will reduce fertilization and seed production of host plants, thereby affecting aspects of nutrient uptake and primary productivity (Chapter 13). An increase in phytophage abundance can increase canopy “porosity”, increasing light penetration, and increasing fluxes of energy, water and nutrients to the soil (Chapter 12). A decline in predator abundance will release prey populations from regulation and contribute to increased exploitation of the prey’s resources. A decline in detritivore abundance can reduce decomposition rate and lead to bottlenecks in biogeochemical cycling that, in turn, affect nutrient availability (Chapter 14).

Population structure across landscapes also influences the source–sink relationships that determine population viability and ability to re-colonize patches following disturbances. For example, the size and distribution of demes determines their ability to maintain gene flow or to diverge into separate species. Distribution of demes determines the source(s) and initial genetic composition of colonists arriving at a new habitat patch. These population attributes are critical to the protection or restoration of rare or endangered species. Isolation of demes as a result of habitat fragmentation can reduce their ability to re-establish local demes, leading to permanent changes in community structure and ecosystem processes across landscapes.

# Population Systems

## I. Population Structure

- A. Density
- B. Dispersion
- C. Metapopulation Structure
- D. Age Structure
- E. Sex Ratio
- F. Genetic Composition
- G. Social Insects

## II. Population Processes

- A. Natality
- B. Mortality
- C. Dispersal

## III. Life History Characteristics

## IV. Parameter Estimation

## V. Summary

### Shift in population state of desert locusts

Population density often exhibits threshold levels at which a population undergoes a rapid transition to a new state, such as irruption or extinction. Small populations (solitary phase) of the desert locust, *Schistocerca gregaria*, are characterized by scattered nymphs and adults feeding and moving independently. However, when environmental conditions favor high rates of reproduction, crowding increases the levels of serotonin in the thoracic ganglia, which causes nymphs to undergo changes in color and form (gregarious phase) and aggregate into small groups (Anstey et al. 2009).

Small groups can coalesce into marching bands of hundreds to millions that cover up to several square kilometers (20–120 nymphs  $m^{-2}$ ). These bands move several kilometers per day and consume all vegetation in their path. Adults developing from these marching nymphs have longer wings than do those developing from solitary nymphs, and they form enormous swarms of millions-to-billions of locusts, covering thousands of hectares and moving thousands of kilometers (Gunn and Brown 1979, Rainey 1963, Rainey and Sayer 1953, Uvarov 1954), consuming all vegetation (e.g.,  $10^8$  kg, Rainey 1963) over large areas. Major outbreaks occur only when small groups remain cohesive, move into neighboring habitats and merge with other groups to form a coordinated band. If such cohesive movement fails to occur, the nymphs disband and return to the solitary phase.

Buhl et al. (2006) studied the behavior of nymphs at various controlled densities and discovered a low incidence of alignment among nymphs at densities  $< 20 m^{-2}$  and long periods of collective motion but rapid spontaneous changes in direction at densities of 25–60  $m^{-2}$ . At

(Cont.)

densities  $> 75 \text{ m}^{-2}$  nymphs adopted a common and persistent direction, and spontaneous changes in direction no longer occurred within the 8-hr observation period, demonstrating a critical density threshold underlying population transition to an irruptive state.

## INTRODUCTION

THE VARIABLES THAT DETERMINE THE ABUNDANCE AND DISTRIBUTION of a population, in time and space, constitute a population system (Berryman 1981). The basic elements of this system are the individual members of the population, variables describing population size and structure, processes that affect population size and structure, and the environment. These elements of the population system largely determine the capacity of the population to maintain itself within a shifting landscape mosaic of habitable and uninhabitable patches. This chapter summarizes these population variables and processes, their integration in life history strategies, and their contribution to change in population size and distribution.

## I. POPULATION STRUCTURE

Population structure reflects several variables that describe the number, age, sex, and genetic composition and spatial distribution of individuals. Population variables reflect life history and the physiological and behavioral attributes that dictate habitat preferences, home ranges, oviposition patterns, and affinity for other members of the population.

### A. Density

Population density is the number of individuals per unit of geographic area, e.g., number per  $\text{m}^2$ , per ha, or per  $\text{km}^2$ . This variable affects a number of other population variables. For example, mean density determines the likelihood of finding mates, hence population viability, and propensity to disperse, hence the probability of colonizing vacant habitat patches. Density also affects the population dispersion pattern (see below) and the behavior of swarming species. Buhl et al. (2006) reported that at a threshold density of  $75 \text{ nymphs m}^{-2}$  in the desert locust, *Schistocerca gregaria*, individual movements became consistently coordinated and directional (see box). This mass marching behavior is a precursor to adult swarms of this insect.

A related measure, population intensity, is commonly used to describe insect population structure. Intensity is the number of individuals per habitat unit, such as number per leaf, per unit branch length, per  $\text{m}^2$  leaf area or bark surface, per kg foliage or wood, etc. Mean intensity indicates the degree of resource exploitation, competition for space, food, or mates, and magnitude of effect on ecosystem processes. Intensity measures often can be converted to density measures if the density of habitat units is known (Southwood 1978).

Densities and intensities of insect populations vary widely. Bark beetles, for example, often appear to be absent from a landscape (very low density) but, with sufficient examination, can be found at high intensities on widely-scattered injured or diseased trees or in the dying tops of trees (Schowalter 1985). Under favorable conditions of climate or host abundance and condition, populations of these beetles can grow up to  $10^5$  individuals per tree over areas as large as  $10^7$  ha (Coulson 1979, Furniss and Carolin 1977). Schell and Lockwood (1997) reported that grasshopper population densities can increase by an order of magnitude over areas of several thousand hectares within one year.

## B. Dispersion

Dispersion is the spatial pattern of distribution of individuals. Dispersion is an important population characteristic, in that it affects the spatial patterns of resource use and the effect of a population on community and ecosystem structure and function. Dispersion patterns can be regular, random, or aggregated.

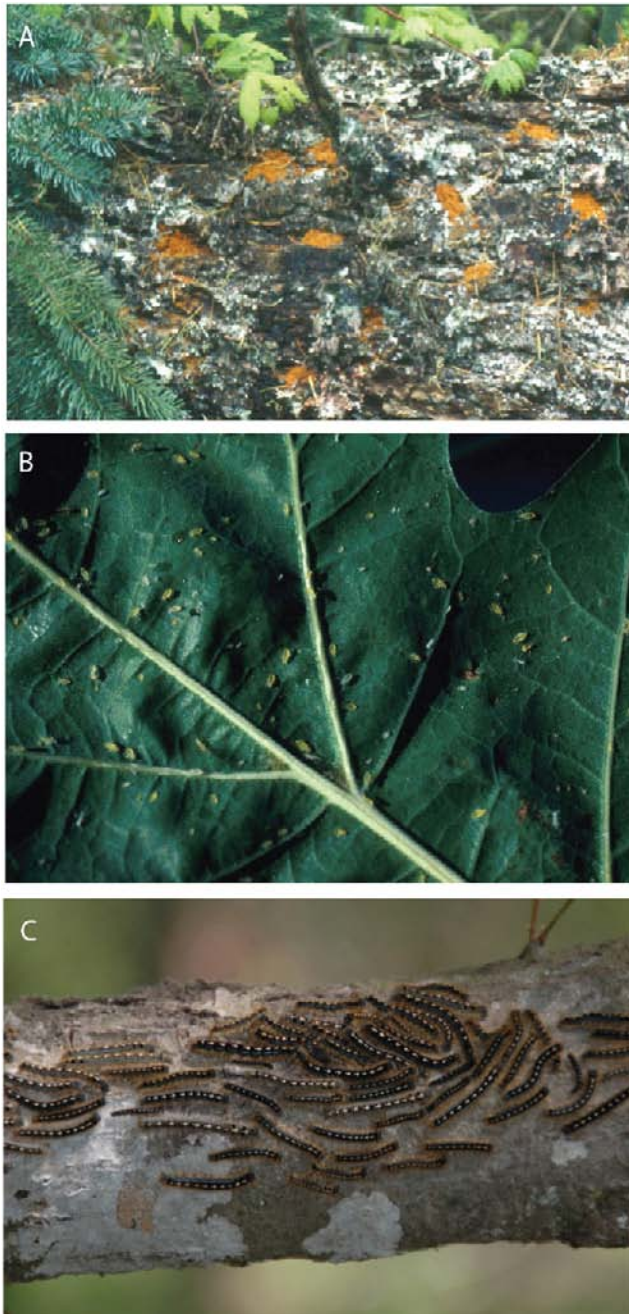
A regular (uniform) dispersion pattern results from individuals spacing themselves at regular intervals within the habitat. This dispersion pattern is typical of species that contest resource use, especially territorial species. For example, bark beetles attacking a tree show a regular dispersion pattern (Fig. 5.1). Similarly, antlion larvae tend to space their pits, minimizing interference to ant (prey) movement among pits (Swenson et al. 2007). Such spacing reduces competition for resources. From a sampling perspective, the occurrence of one individual in a sample unit reduces the probability that other individuals will occur in the same sample unit. Variability in mean density is low, and sample densities tend to be normally distributed. Hence, regularly dispersed populations are most easily monitored, because a relatively small number of samples will provide estimates of mean and variance in population density that are similar to those from a larger number of samples.

In a randomly dispersed population, individuals neither space themselves apart nor are attracted to each other. The occurrence of one individual in a sample unit has no effect on the probability that other individuals will occur in the same sample unit (Fig. 5.1). Sample densities show a skewed (Poisson) distribution. Most populations are dispersed randomly.

Aggregated (or clumped) dispersion results from grouping behavior or preference for particular habitat patches. Aggregation is typical of species that occur in herds, flocks, schools, etc. (Fig. 5.1) in order to enhance resource exploitation or protection from predators (see Chapter 3). Gregarious sawfly larvae and tent caterpillars are examples of aggregated dispersion, that results from a tendency of individuals to form groups (Fig. 2.11). Filter feeding aquatic insects tend to be aggregated in riffles or other zones of higher flow rate within the stream continuum (e.g., Fig. 2.12), whereas predators that hide in benthic detritus, such as dragonfly larvae or water scorpions, are aggregated in pools, due to their habitat preferences. Aphids may be aggregated as a result of rapid, pathenogenic reproduction, as well as host and habitat preferences. Massonnet et al. (2002) found that the aphid, *Macrosiphoniella tanacetaria*, a specialist on tansy, *Tanacetum vulgare*, can be aggregated at the level of individual shoots, plants, and sites.

In this type of population distribution, for sampling purposes, the occurrence of an individual in a sample unit increases the probability that additional individuals will occur in that sample unit. Sample densities are distributed as a negative binomial function, and variance tends to be high. Populations with this dispersion pattern require the greatest number of samples and attention to experimental design. A large number of samples is necessary to minimize the obviously high variance in numbers of individuals among sample units and to ensure adequate representation of aggregations. A stratified experimental design can facilitate adequate representation with smaller sample sizes if the distribution of aggregations among different habitat types is known.

The pattern of dispersion can change during insect development, during change in population density or across spatial scales. For example, larval stages of tent caterpillars and gregarious sawflies are aggregated at the plant branch level, but adults are randomly dispersed at this scale (Fitzgerald 1995, McCullough and Wagner 1993). Many host-specific insects are aggregated on particular hosts in diverse communities, but are more regularly or randomly dispersed in more homogeneous communities dominated by hosts. Some



**FIG. 5.1** Dispersion patterns and their frequency distributions: A) regular dispersion of Douglas-fir beetle, *Dendroctonus pseudotsugae*, entrances (marked by the small piles of reddish phloem fragments) through bark on a fallen Douglas-fir tree, B) random dispersion of aphids on an oak leaf, C) aggregated dispersion of forest tent caterpillars, *Malacosoma disstria*.

insects, such as the western ladybird beetle, *Hippodamia convergens*, aggregate for overwintering purposes and redispersed in the spring. Aphids are randomly dispersed at low population densities, but become more aggregated as scattered colonies increase in size (Dixon 1985). Bark beetles show a regular dispersion pattern on a tree bole, due to spacing behavior, but are aggregated on injured or diseased trees (Coulson 1979).

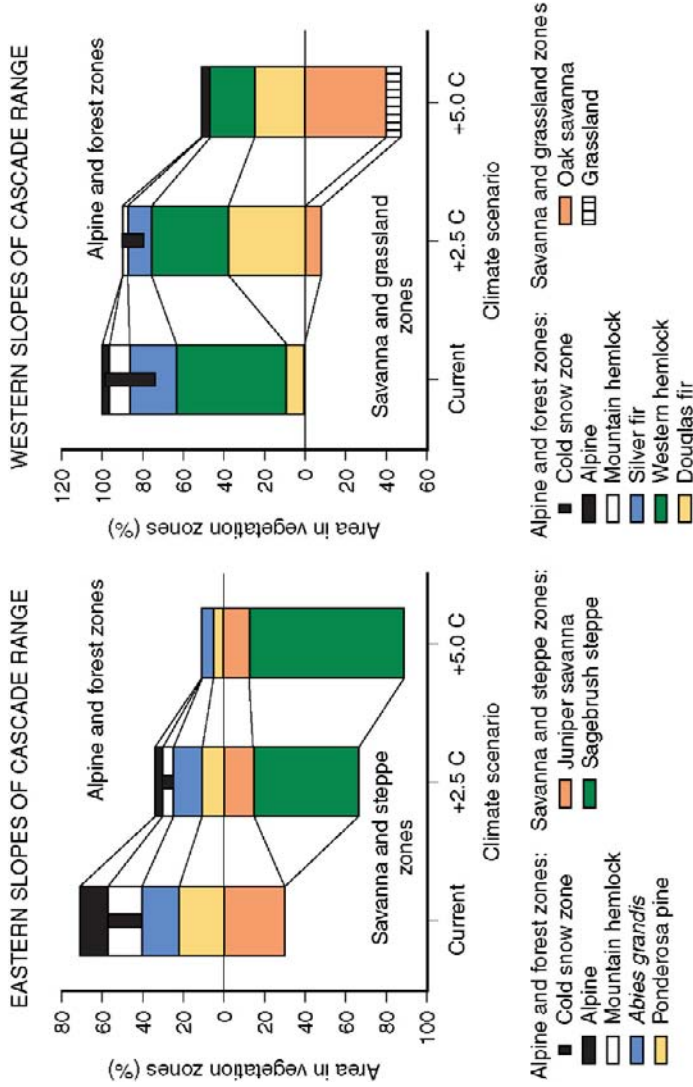
### C. Metapopulation Structure

The irregular distribution of many populations across landscapes creates a pattern of relatively distinct (often isolated) local demes (aggregations) that compose the greater metapopulation (Hanski and Gilpin 1997). Insect species that characterize discrete habitat types are often dispersed as relatively distinct local demes, which occur as a result of environmental gradients or disturbances that affect the distribution of habitat types across the landscape. Obvious examples include insects associated with lotic or high elevation ecosystems. Populations of insects that are associated with ponds or lakes show a dispersion pattern which reflects the dispersion of their habitat units. Demes of lotic species are more isolated in desert ecosystems than in mesic ecosystems. Populations of the western spruce budworm, *Choristoneura occidentalis*, and fir engraver beetle, *Scolytus ventralis*, historically occurred in western North America in relatively isolated high elevation and riparian fir forests separated by more xeric patches of pine forest (Wickman 1992). However, many monophagous species show metapopulation structure associated with the distribution of their host plant (St. Pierre et al. 2005).

Metapopulations typically are composed of demes of various sizes, reflecting the size and/or quality of habitat patches. For example, Leisnham and Jamieson (2002) found that demes of mountain stone weta, *Hemideina maori*, which shelter under rocks on isolated outcrops (tors) in alpine habitats in southern New Zealand, ranged in size from 0–6 adults on tors with 1–12 rocks to 15–40 adults on tors with 30–40 rocks. Small tors were more likely to experience extinction events (4 of 14 small tors experienced at least one extinction during the 3-year study) than were large tors (which had no extinction events during the study).

Population structure among suitable patches is influenced strongly by the matrix of patch types. Haynes and Cronin (2003) studied the distribution of planthoppers, *Prokelisia crocea*, among discrete patches of prairie cordgrass, *Spartina pectinata*, as affected by surrounding mudflat, native non-host grasses, or exotic smooth brome, *Bromus inermis*. Planthoppers were released into experimental cordgrass patches, that were constructed to be identical in size (about 24 x 24 cm), in isolation (> 25 m from natural cordgrass patches) and in host plant quality. Within the patches, planthopper density was higher against mudflat edges, relative to patch interior, but not against non-host patches. Among patches, density increased as the proportion of surrounding matrix that was composed of mudflat increased. The influence of matrix composition was equal to the influence of patch size and isolation in explaining planthopper distribution.

Population distribution and degree of isolation among local demes affect both gene structure and viability of the metapopulation. If local demes become too isolated, they become inbred and may lose their ability to recolonize habitable patches following local extinction (Hedrick and Gilpin 1997). As human activities increasingly fragment natural ecosystems, local demes become isolated at a faster rate than greater dispersal ability can evolve, and species extinction becomes more likely. These effects of fragmentation could be exacerbated by climate change. For example, a warming climate will push high elevation ecosystems into smaller areas on mountaintops, and some mountaintop ecosystems will disappear (Fig. 5.2) (Franklin et al. 1992, D. Williams and Liebhold 2002).



**FIG. 5.2** Changes in the percent area of major vegetation zones on the eastern (left) and western (right) slopes of the Cascade Range in Oregon as a result of temperature increases of 2.5 °C and 5 °C. Major changes are predicted in elevational boundaries and total area occupied by vegetation zones under these global climate change scenarios. Vegetation zones occupying higher elevations will decrease in area or disappear as a result of the smaller conical surface at higher elevations. Other species associated with vegetation zones also will become more or less abundant. From Franklin et al. (1992) with permission from Yale University Press.

Rubenstein (1992) showed that individual tolerances to temperature changes could affect range changes by insects under warming climate scenarios. A species with a linear response to temperature could extend its range to higher latitudes (provided that expansion was not limited by habitat fragmentation) without reducing its current habitat. Conversely, a species with a dome-shaped response to temperature could extend into higher latitudes, but would be forced to retreat from lower latitudes if these became too warm. If the pathway for range adjustment for this species were blocked by an unsuitable habitat, it would face extinction. Metapopulation dynamics are discussed in more detail in Chapter 7.

#### D. Age Structure

Age structure reflects the proportions of individuals at different life stages. This variable is an important indicator of population status. Growing populations generally have larger proportions of individuals in younger age classes, whereas declining populations typically have smaller proportions of individuals in these age classes. Stable populations typically have relatively more individuals in reproductive age classes. However, populations with larger proportions of individuals in younger age classes also may reflect low survival rates in these age classes, whereas populations with smaller proportions of individuals in younger age classes may reflect high survivorship (see below).

For most insect species, life spans are short (usually  $\leq 1$  year) and revolve around seasonal patterns of temperature and rainfall. Oviposition typically is timed to ensure that the feeding stages coincide with the most favorable seasons, and that diapausing stages occur during unfavorable seasons, e.g., winter in temperate regions and the dry season in tropical and arid regions. Adults typically die after reproducing. Most temperate species have discrete, annual generations, whereas tropical species are more likely to have overlapping generations.

Periodical cicadas, *Magicicada* spp., represent a major exception. Distinct broods of 13- and 17-year periodical cicadas emerge as adults following 13- or 17-year developmental periods underground. Y. Tanaka et al. (2009) demonstrated that the synchronization of prime-numbered life spans among these cicadas could be explained by the lower likelihood of hybridization with cicadas of other cyclic patterns and by their increased likelihood of persistence and selection under variable environmental conditions that could lead to extinction of low-density populations (see the Allee effect below). Emergence densities of these insects can exceed  $100 \text{ m}^{-2}$ , when they represent an important resource for predators (Whiles et al. 2001, Whitford and Jackson 2007).

#### E. Sex Ratio

The proportion of females indicates the reproductive potential of a population. The sex ratio also reflects a number of life history traits, such as the importance of sexual reproduction, the mating system, and the ability of the species to exploit harsh or ephemeral habitats (Pianka 1974).

A 50:50 sex ratio generally indicates equally important roles for males and females, given that selection would minimize the less productive sex. The sex ratio approaches this value in species where males select resources, protect or feed females, or contribute necessary genetic variability. This sex ratio maximizes the availability of males to females, hence maximizes genetic heterogeneity. High genetic heterogeneity is particularly important for population survival in heterogeneous environments. However, when the sexes are equally abundant, only half of the population is capable of producing offspring, but all compete for resources. By contrast, a parthenogenetic population (one which has no



males) has little or no genetic heterogeneity, but the entire population is capable of producing offspring. Parthenogenetic individuals can disperse and colonize new resources without the additional challenge of finding mates, and successful colonists can generate large population sizes rapidly, thus ensuring the exploitation of suitable resources and production of large numbers of dispersants in the next generation.

The sex ratio can be affected by environmental factors. For example, haploid males of many insect species are more sensitive to environmental variation than are diploid females, and greater mortality of haploid males may speed adaptation to changing conditions, by quickly eliminating deleterious genes (Edmunds and Alstad 1985, J. Peterson and Merrell 1983).

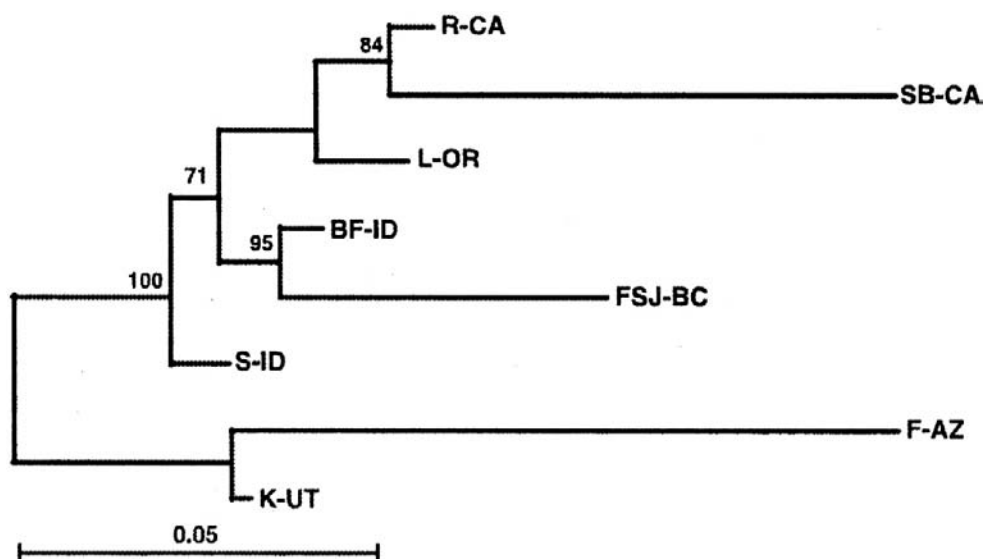
## F. Genetic Composition

All populations show variation in genetic composition (frequencies of various alleles) among individuals and through time. The degree of genetic variability and the frequencies of various alleles depend on a number of factors, including mutation rate, environmental heterogeneity, and population size and mobility (Hedrick and Gilpin 1997, Mopper 1996, Mopper and Strauss 1998). Genetic variation may be partitioned among isolated demes or affected by patterns of habitat use (Hirai et al. 1994). Genetic structure, in turn, affects various other population parameters, including population viability (G. Bell and Gonzalez 2009, Hedrick and Gilpin 1997).

Populations vary in the frequency and distribution of various alleles. Widespread species might be expected to show greater variation across their geographic range than would more restricted species. Roberds et al. (1987) measured genetic variation from local to regional scales for the southern pine beetle, *Dendroctonus frontalis*, in the southeastern U.S. They reported that allelic frequencies were somewhat differentiated among populations from Arkansas, Mississippi and North Carolina, but that a population in Texas was distinct. They found little or no variation among demes within each state, and evidence of considerable inbreeding among beetles at the individual tree level. Roberds et al. (1987) also reported that only one allele of the seven analyzed showed significant variation between the demes that were growing and colonizing new trees and those demes not growing or colonizing new trees.

Mock et al. (2007) examined genetic variation in mountain pine beetle, *Dendroctonus ponderosae*, populations across their range in western North America using amplified fragment length polymorphism (AFLP) and mitochondrial sequencing analysis. They concluded that genetic divergence increased with geographic distance between populations, that gene flow occurred primarily around, rather than across, the Great Basin desert, and that patterns of genetic diversity and divergence indicated a northward expansion of this species from post-glacial refugia (Fig. 5.3).

The genetic variation among the founders of a new deme is relatively low, simply because of the small number of colonists and the limited proportion of the gene pool that they represent. Colonists from a population with low genetic variability start a population with even lower genetic variability (Hedrick and Gilpin 1997). Therefore, the size and genetic variability of the source population, as well as the number of colonists, will determine genetic variability in founding populations. Genetic variability remains low during population growth, unless it is augmented by new colonists. This is especially true for parthenogenetic species, such as aphids, for which an entire population could represent a clone derived from a founding female. Differential dispersal ability among genotypes affects the heterozygosity of colonists. Florence et al. (1982) reported that the frequencies



**FIG. 5.3** Unrooted neighbor-joining dendrogram of mountain pine beetle, *Dendroctonus ponderosae*, populations based on amplified fragment length polymorphism marker data (159 loci) using  $D_a$  genetic distance. The percentage of 1000 bootstrap pseudoreplicates (over loci) reproducing a particular node is provided. Population abbreviations are R-CA = Klamath, Oregon, SB-CA = San Bernadino, California, L-OR = La Grande, Oregon, BF-ID = Bonner's Ferry, Idaho, FSJ-BC = Fort St. James, British Columbia, S-ID = Stanley, Idaho, F-AZ = Flagstaff, Arizona, and K-UT = Kamas, Utah. From Mock et al. (2007) with permission from the authors and John Wiley & Sons.

of four alleles for an esterase (esB) converged in southern pine beetles that were collected along a 150 m transect extending from an active infestation in eastern Texas. As a result, the heterozygosity increased significantly with distance, approaching the theoretical maximum of 0.75 for a gene locus with four alleles. These data suggested a system that compensates for loss of genetic variability due to inbreeding by small founding populations, and maximizes genetic variability in new populations coping with different selection regimes (Florence et al. 1982). Nevertheless, dispersal among demes is critical to maintaining genetic variability (Hedrick and Gilpin 1997). If isolation restricts dispersal and the infusion of new genetic material into local demes, inbreeding may reduce the ability of the population to adapt to changing conditions, and recolonization following local extinction will be more difficult. G. Bell and Gonzalez (2009) demonstrated that population recovery following collapse depends on a sufficiently large pre-collapse population size and genetic diversity, above a threshold, to support increase by adapted individuals.

Polymorphism occurs commonly among insects and may underlie their rapid adaptation to environmental change or other selective pressures, such as predation (A. Brower 1996, Sheppard et al. 1985). Among the best known examples of population response to environmental change is the industrial melanism that developed in the peppered moth, *Biston betularia*, in England following the industrial revolution (Kettlewell 1956). Selective predation by insectivorous birds was the key to the rapid shift in dominance from the white form, cryptic on light surfaces provided by lichens on tree bark, to the black form, which was more cryptic on trees blackened by industrial effluents. Birds that preyed on the more conspicuous morph maintained the low frequencies of the black

form pre-industrial England, but later they greatly reduced the frequencies of the white form. Other examples of polymorphism also appear to be maintained by selective predation. In some cases, predators focusing on inferior Müllerian mimics of multiple sympatric models may select for morphs or demes that mimic different models (e.g., A. Brower 1996, Sheppard et al. 1985).

Mondor et al. (2005) examined effects of elevated CO<sub>2</sub> and O<sub>3</sub> on a genetically polymorphic population of pea aphids, *Acyrtosiphon pisum*, over multiple generations using a free air carbon enrichment (FACE) facility. The green genotype was positively affected by elevated CO<sub>2</sub> levels, but the pink genotype was not, leading to increased frequency of the green genotype in this population over time.

Genetic polymorphism can develop in populations that use multiple habitat units or resources (Mopper 1996, Mopper and Strauss 1998, Via 1990). Sturgeon and Mitton (1986) compared allelic frequencies among mountain pine beetles, *D. ponderosae*, collected from three pine hosts [ponderosa (*Pinus ponderosa*), lodgepole (*Pinus contorta*) and limber (*Pinus flexilis*)] at each of five sites in Colorado. Significant variation occurred in morphological traits and allelic frequencies at five polymorphic enzyme loci among the five populations and among beetles from the three host species, suggesting that the host species is an important contributor to the genetic structure of polyphagous insect populations.

Via (1991a) compared the fitnesses (longevity, fecundity, and capacity for population increase) of *A. pisum* clones from two host plants (alfalfa and red clover) on their source host or the alternate host. She reported that aphid clones had higher fitnesses on their source host, compared to the host to which they were transplanted, indicating local adaptation to factors associated with host conditions. Furthermore, significant negative correlations for fitness between source host and alternate host indicated increasing divergence between aphid genotypes associated with different hosts. In a subsequent study, Via (1991b) evaluated the relative importances of genetics and experience on aphid longevity and fecundity on source and alternate hosts. She maintained replicate lineages of the two clones (from alfalfa vs. clover) on both host plants for three generations, then tested the performance of each lineage on both hosts. If genetics is the more important factor that affects aphid performance on source and alternate host, then the aphids should have the highest fitness on the host to which they were adapted, regardless of subsequent rearing on the alternate host. On the other hand, if experience is the more important factor, then aphids should have highest fitness on the host from which they were reared. Via found that three generations of experience on the alternate host did not significantly improve fitness on that host. Rather, fitness was highest on the plant from which the clone was derived originally, supporting the hypothesis that genetics is the more important factor. These data indicated that continued genetic divergence of the two subpopulations is likely, given that individuals dispersing between alternate hosts cannot improve their performance through time as a result of experience.

Biological factors that determine mate selection or mating success also affect gene frequencies, perhaps in concert with environmental conditions. In a laboratory experiment with sex-linked mutant genes in *Drosophila melanogaster* (J. Peterson and Merrell 1983), mutant and wild male phenotypes exhibited about the same viability, but mutant males showed a significant mating disadvantage, leading to rapid elimination (i.e., within a few generations) of the mutant allele. In addition, whereas the wild male phenotype tended to show a rare male advantage in mating, i.e., a higher proportion of males mating at low relative abundance, mutant males showed a rare male disadvantage, i.e., a lower proportion of males mating at low relative abundance, increasing their rate of elimination.

Malausa et al. (2005) used a combination of genetic and stable isotope ( $^{13}\text{C}$ ) techniques to identify the host plant sources of 396 male and 393 female European corn borers, *Ostrinia nubilalis*, collected at multiple sites, and of 535 spermatophores carried by these females, over a two-year period (2002–2003). Moths could be differentiated unambiguously on the basis of their larval host, either  $\text{C}_3$  or  $\text{C}_4$  plants. All but five females (three in 2002 and two in 2003) had mated with a male from the same host race, indicating > 95% assortative mating. These data indicate that non-random mating patterns can lead to rapid changes in gene frequencies among diverging races from different hosts.

Insect populations can adapt to environmental change more rapidly than can longer lived, more slowly reproducing, organisms (Mopper 1996, Mopper and Strauss 1998). Heterogeneous environmental conditions tend to mitigate directional selection: any strong directional selection by any environmental factor during one generation can be modified in subsequent generations by a different prevailing factor. However, changes in genetic composition occur quickly in insects when environmental change does impose directional selective pressure, such as in the change from pre-industrial to post-industrial morphotypes in the polymorphic peppered moth (Kettlewell 1956).

The shift from pesticide-susceptible to pesticide-resistant genotypes may be particularly instructive. The selective pressure that was imposed by insecticides caused the rapid development of insecticide-resistant populations in many species. The development of resistance is facilitated by the widespread occurrence in insects, especially herbivores, of genes that encode for enzymes that detoxify plant defenses, since ingested insecticides also are susceptible to detoxification by these enzymes (see Chapter 3). Although avoidance of directional selection for resistance to any single tactic is a major objective of integrated pest management (IPM), pest management in practice still involves the widespread use of the most effective (initially) tactic. Following the appearance of transgenic insect-resistant crop species in the late 1980s, genetically-engineered, Bt toxin-producing, corn, cotton, soybeans, and potatoes have replaced non-transgenic varieties over large areas, raising concern that these crops might quickly select for resistance in target species (Alstad and Andow 1995, Heuberger et al. 2008a, b, Tabashnik 1994, Tabashnik et al. 1996).

Laboratory studies have shown that at least 16 species of Lepidoptera, Coleoptera and Diptera are capable of developing resistance to the Bt gene as a result of strong selection (Tabashnik 1994). However, few species have shown resistance in the field. The diamondback moth, *Plutella xylostella*, has shown resistance to Bt in field populations from the U.S., Philippines, Malaysia and Thailand. Resistance in some species has been attributed to the reduced binding of the toxin to membranes of the midgut epithelium. A single gene confers resistance to four Bt toxins in the diamondback moth (Tabashnik et al. 1997), and >5,000-fold resistance can be achieved in a few generations (Tabashnik et al. 1996). Resistance can be reversed when exposure to Bt toxin is eliminated for several generations, probably because of fitness costs of resistance (Tabashnik et al. 1994), but some strains can maintain resistance in the absence of Bt for more than 20 generations (Tabashnik et al. 1996).

## G. Social Insects

Social insects pose some special problems for the description of their population structure. On the one hand, each individual requires resources and contributes to interactions with other organisms. On the other hand, colony member activity is centered on the nest, and the collective foraging territory is defined by its proximity to surrounding colonies. Food transfer among nestmates (trophallaxis) supports a view of colonies as sharing a

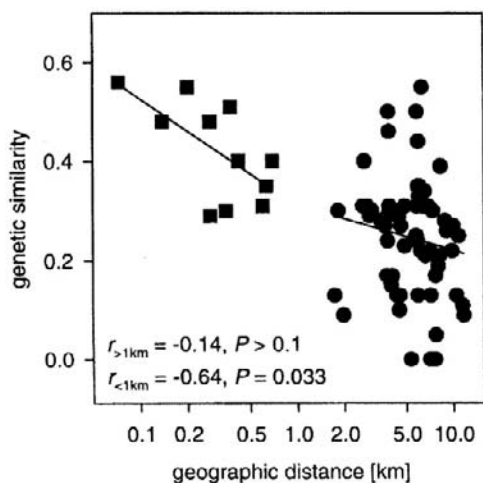
collective gut. Colonies often have defined spatial structure in their parts and activities, with the queen and larvae located in the deepest chambers and progressively older workers moving upward and performing a sequence of tasks associated with vertical location, e.g., brood care by young workers in the deepest levels and foraging and food storage by the oldest workers near the surface (Tschinkel 1999). In the case of army ants, *Dorylus* spp., each colony moves as an intact entity (Schöning et al. 2005). Colony members recognize and accept other colony members, but chemosensory detection of non-colony members elicits rejection and aggression (Ozaki et al. 2005). Caste regulation within colonies may depend on colony size. L. Mao and Henderson (2010) found that if the density of Formosan subterranean termite, *Coptotermes formosanus*, workers increased, the concentration of juvenile hormone, that is responsible for transformation of workers to soldiers, also increased. However, the presence of soldiers reduced the effect of rising juvenile hormone level, stabilizing the proportion of soldiers in colonies.

Hence, each colony appears to function as a distinct ecological unit, with colony size (number of members) determining its individual structure, physiology and behavior. For some social insects, the number of colonies per hectare may be a more useful measure of density than is the number of individuals per hectare. However, defining colony boundaries and distinguishing between colonies may be problematic for many species, especially those with underground nests. Molecular techniques have proven to be a valuable tool for evaluating relatedness within and among colonies in an area (Husseneder et al. 2003).

Colonies of social Hymenoptera can be monogyne (having one queen) or polygyne (having multiple queens), with varying degrees of relatedness among queens and workers (Goodisman and Hahn 2004, Pamilo et al. 1997). Intra-colony relatedness can vary among colonies and among populations. For example, Goodisman and Hahn (2004) reported that DNA microsatellite markers in the carpenter ant, *Camponotus ocreatus*, indicated that the genotypes of queens, workers and males in 15 of 16 nests that were analyzed were consistent with a single, once-mated queen, but that nestmate genotypes in the remaining nest were more complex, suggesting infrequent inbreeding, polygyny and polyandry. In other ants, such as *Solenopsis invicta* and some *Formica* species, social polymorphism can be observed, with distinct monogynous (M type) and polygynous (P type) colonies (Pamilo et al. 1997). The two types generally show high relatedness to each other where they occur in the same area. However, gene flow is restricted in the polygynous type and between monogynous and polygynous types. Populations of polygynous colonies generally are more genetically differentiated than are those of monogynous colonies in the same area (Pamilo et al. 1997).

Polygyny may be advantageous in areas of intense competition, where the more rapid reproduction by multiple queens may confer an advantage, regardless of the relatedness of the queens. However, additional queens eventually may be eliminated, especially in ant species, with workers often favoring queens on the basis of their size or condition, rather than which queen is mother to most workers (Pamilo et al. 1997).

Similarly, termite colonies are cryptic and may have variable numbers of reproductive adults. Husseneder and Grace (2001b) and Husseneder et al. (1998) found DNA fingerprinting to be more reliable than aggression tests or morphometry for distinguishing termites from different colonies or sites. As expected, genetic similarity is higher among termites within collection sites than between collection sites, and it declines with distance between colonies (Fig. 5.4) (Husseneder and Grace 2001a, Husseneder et al. 1998). Moderate inbreeding is often evident within termite colonies, but the low observed levels of genetic differentiation at regional scales suggests that substantial dispersal of winged adults homogenizes the genetic structure of the population (Husseneder et al. 2003). However, several



**FIG. 5.4** Relationship between genetic similarity and spatial distance for 13 termite, *Schedorhinotermes lamanianus*, colonies representing 100 km<sup>2</sup> in the Shimba Hills Nature Reserve in Kenya. From Husseneder et al. (1998) with permission from John Wiley & Sons.

species are polygynous and may show greater within-colony genetic variation, depending on the extent to which multiple reproductives are descended from a common parent (Vargo et al. 2003). Kaib et al. (1996) found that foraging termites tended to associate with close kin in polygynous and polyandrous colonies of *Schedorhinotermes lamanianus*, leading to greater genetic similarity among termites within foraging galleries than at the nest center.

Genetic studies have challenged the traditional view of the role of genetic relatedness in the evolution and maintenance of eusociality. Eusociality in the social Hymenoptera has been explained by the high degree of genetic relatedness among siblings, which share 75% of their genes as a result of haploid father and diploid mother, compared to only 50% genes shared with their mother (W. Hamilton 1964, See Chapter 15). However, this model does not apply to termites. Husseneder et al. (1999), Thorne (1997) and Thorne and Traniello (2003) suggested that developmental and ecological factors, such as slow development, iteroparity, overlap of generations, food-rich environment, high risk of dispersal, and group defense, may be more important than genetics in the maintenance of termite eusociality, whatever factors may have favored its original development. Myles (1999) reviewed the frequency of neoteny (reproduction by immature stages) among termite species and concluded that neoteny is a primitive element of the caste system that may have reduced the fitness cost of not dispersing, leading to further caste differentiation and early evolution of eusociality.

## II. POPULATION PROCESSES

The population variables described above change as a result of the differential reproduction, movement and death of individuals. These individual contributions to population change are integrated as three population processes: natality (birth rate), mortality (death rate) and dispersal (rate of movement of individuals into or out of the population). For example, density can increase as a result of increased birth rate and/or immigration; frequencies of

various alleles change as a result of differential reproduction, survival and dispersal. The rate of change in these processes determines the rate of population change, as described in the next chapter. Therefore, these processes are fundamental to understanding population responses to changing environmental conditions.

## A. Natality

Natality is the population birth rate, i.e., the per capita production of new individuals per unit time. Realized natality is a variable that approaches potential natality, which is the maximum reproductive capacity of the population, only under ideal environmental conditions. Natality is affected by factors that influence the production of eggs (fecundity) or of viable offspring (fertility) by individual insects. For example, resource quality can affect the numbers of eggs produced by female insects (R. Chapman 1982). Ohgushi (1995) reported that females of the herbivorous ladybird beetle, *Henosepilachna niponica*, feeding on the thistle, *Cirsium kagamontanum*, resorbed eggs in the ovary when leaf damage became high. Female blood-feeding mosquitoes often require a blood meal before first or subsequent oviposition can occur (R. Chapman 1982); the ceratopogonid, *Culicoides barbosai*, produces eggs in proportion to the size of the blood meal (Linley 1966). Hence, poor quality or insufficient food resources can reduce natality. Inadequate numbers of males can reduce fertility in sparse populations. Similarly, availability of suitable oviposition sites also affects natality.

Natality is typically higher at intermediate population densities than at low or high densities. At low densities, difficulty attracting mates may limit mating, or may limit necessary cooperation among individuals, as in the case of bark beetles that must aggregate in order to overcome host tree defenses prior to oviposition (Berryman 1981). At high densities, competition for food, mates, and oviposition sites reduces fecundity and fertility (e.g., Southwood 1975, 1977). The influence of environmental conditions can be evaluated by comparing realized natality to potential natality, e.g., as estimated under laboratory conditions.

Differences among individual fitnesses are integrated in an overall value of natality. Differential reproduction among genotypes in the population determines the frequency of various alleles in the filial generation. As discussed above, gene frequencies can change dramatically within a relatively short time, given strong selection and the short generation times and high reproductive capacity of insects.

## B. Mortality

Mortality is the population death rate, i.e., the per capita number of individuals dying per unit time. As with natality, we can distinguish a potential longevity or life span, resulting only from physiological senescence, from the realized longevity, resulting from the action of mortality factors. Hence, mortality can be viewed both as reducing the number of individuals in the population and as reducing survival. Both have important consequences for population dynamics.

Organisms are vulnerable to a variety of mortality agents, including unsuitable habitat conditions (e.g., extreme temperature or water conditions), toxic or unavailable food resources, competition, predation (including cannibalism), parasitism, and disease (see Chapters 2–4). These factors are a focus of studies to enhance pest management efforts. Death can result from insufficient energy or nutrient acquisition to permit detoxification of, or continued search for, suitable resources. Life stages are affected differentially by

these various mortality agents (e.g., Fox 1975b, Varley et al. 1973). For example, immature insects are particularly vulnerable to desiccation during molts, whereas flying insects are more vulnerable to predation by birds or bats. Many predators and parasites selectively attack certain life stages. Among parasitic Hymenoptera, species attacking the same host have different preferences for host egg, larval or pupal stages. Predation also can be greater on hosts feeding on particular plant species, compared to other plant species, based on differential toxin sequestration, or predator attraction to plant volatiles (Stamp 1992, Traugott and Stamp 1996, Turlings et al. 1990, 1995).

In general, mortality due to predation tends to peak at intermediate population densities, when density is sufficient for a high rate of encounter with predators and parasites, but prior to predator satiation (Fig. 5.5) (Southwood 1975, 1977, see Chapter 8). Mortality due to competition and cannibalism increases at higher population densities (Fig. 5.5) (Fox 1975a, b, Southwood 1975, 1977). Competition may cause mortality through starvation, cannibalism, increased disease among stressed individuals, displacement of individuals from optimal habitats, and increased exposure and vulnerability to predation as a result of displacement or delayed development.

Survival rate represents the number of individuals still living in relation to time. These individuals continue to feed and reproduce, thereby contributing most to population size, as well as to genetic and ecological processes. Hence, survival rate is an important measure in studies of populations.

Survivorship curves reflect patterns of mortality and can be used to compare the effect of mortality in different populations. Lotka (1925) pioneered the comparison of survivorship curves among populations, by plotting the log of number or percent of living individuals against time. Pearl (1928) later identified three types of survivorship curves, based on the log of individual survival through time (Fig. 5.6). Type 1 curves represent species, including most large mammals, but also starved *Drosophila* (Price 1997), in which mortality is concentrated near the end of the maximum lifespan. Type 2 curves represent species in which the probability of death is relatively constant with age, leading to a linear decline in survivorship. Many birds and reptiles approach the Type 2 curve. Type 3 curves are seen for most insects, as well as many other invertebrates and fish, which have high rates of mortality during early life stages, but relatively low mortality during later life stages (Begon and Mortimer 1981, Pianka 1974). Species representing Type 3 survivorship must have very high rates of natality to ensure that some offspring reach reproductive age, compared to Type 1 species which have a high probability of reaching reproductive age.

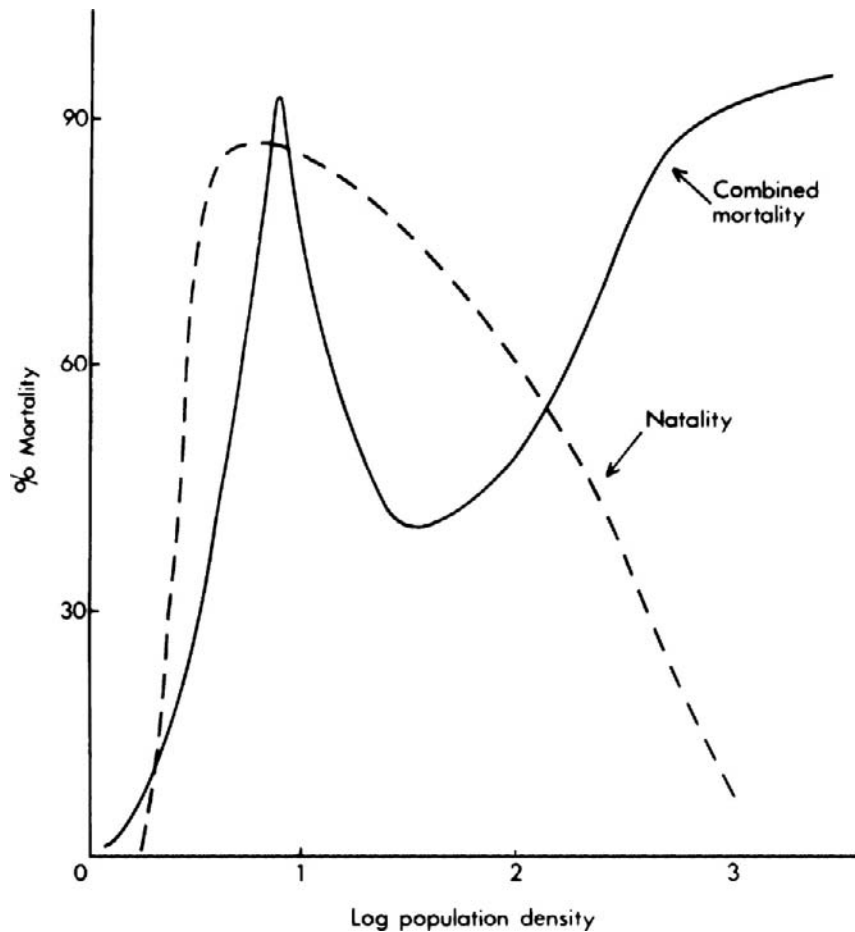
The form of the survivorship curve can change during population growth. Mason and Luck (1978) showed that survivorship curves for the Douglas-fir tussock moth, *Orgyia pseudotsugata*, changed with population growth from stable, to increasing, then decreasing. Survivorship decreased less steeply during population growth and decreased more steeply during population decline, compared to stable populations.

As described for natality, mortality integrates the differential survival among various genotypes, which is the basis for evolution. Survivors live longer and have greater capacity to reproduce. Hence, selective mortality can alter gene frequencies rapidly in insect populations.

### C. Dispersal

Dispersal is the movement of individuals away from their source, and includes **spread**, the local movement of individuals, and **migration**, the cyclic mass movement of individuals



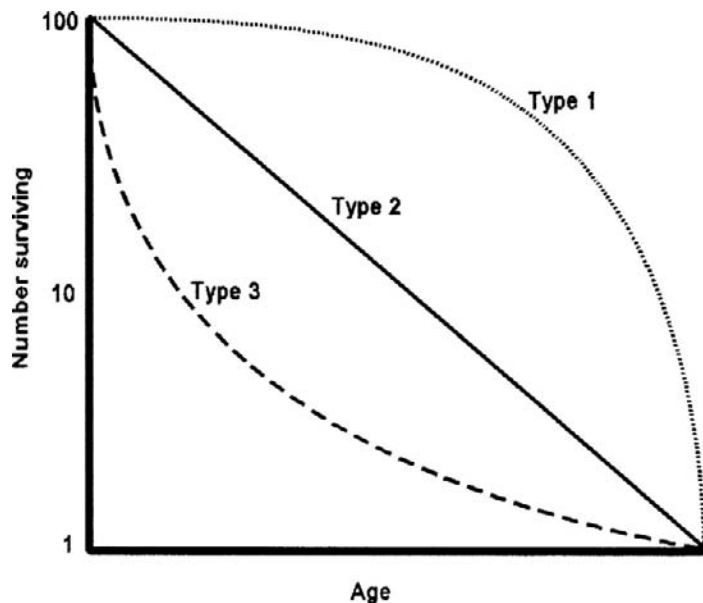


**FIG. 5.5** Relationship between population density, natality, and mortality caused by predators and parasites (peaking at lower population density) and interspecific competition (peaking at a higher population density). From Southwood (1975).

among areas (L. Clark et al. 1967, Nathan et al. 2003). As discussed in Chapter 2, long distance dispersal maximizes the probability that habitat or food resources that have been created by environmental changes or disturbances are colonized before the source population depletes its resources or is destroyed by disturbance. However, dispersal also contributes to infusion of new genetic material into populations. This contribution to genetic heterogeneity enhances the capacity of the population to adapt to changing conditions.

Dispersal incorporates emigration, movement away from a source population, and immigration, movement of dispersing individuals into another population or vacant habitat. Immigration adds new members to the population, or founds new demes, whereas emigration reduces the number of individuals in the population.

Effective dispersal, the number of individuals that successfully immigrate or find new demes, is the product of source strength (the number of individuals dispersing) and the individual probability of success (Nathan et al. 2003, Price 1997, see Chapter 2). Source strength is a function of population size, density, and life history strategy. The individual probability of successful dispersal is determined by dispersal mechanism,



**FIG. 5.6** Three generalized types of survivorship curves. Type 1 represents species with high survival rates maintained through the potential life span. Type 2 represents species with relatively constant survivorship with age. Type 3 represents species with low survival rates during early stages, but relatively high survival of individuals reaching more advanced ages.

individual capacity for long distance dispersal, the distance between source and sink (destination), patch size, and habitat heterogeneity, as described below (see also Chapters 2 and 7).

Species which characterize ephemeral habitats or resources have adapted a greater tendency to disperse than have species characterizing more stable habitats or resources. For example, species that are found in vernal pools or desert playas tend to produce large numbers of dispersing offspring before the water level begins to decline. This ensures that other suitable ponds are colonized and buffers the population against local extinctions. Monophagous herbivore species that feed on host plants with stable distributions tend to show lower dispersal frequencies and distances than do species that feed on host plants with more variable distributions (St. Pierre et al. 2005). Some dispersal-adapted species produce a specialized morph for dispersal. The dispersal form of most aphids and many scale insects is winged, whereas the feeding form typically is wingless and sedentary. Under crowded conditions, migratory locusts develop into a specialized long-winged morph (the gregarious phase), that is capable of long-distance migration and is distinct from the shorter-winged non-dispersing morph (solitary phase) (Anstey et al. 2009). Some mites have dispersal stages that are specialized for attachment to phoretic hosts, e.g., ventral suckers in the hypopus of astigmatid mites and anal pedicels in uropodid mites (Krantz 1978).

Some species have obligatory dispersal prior to reproduction. Cronin and Strong (1999) reported that parasitoid wasps, *Anagrus sophiae*, laid >84% of their eggs in host planthoppers, *Prokelisia* spp., on cordgrass, *Spartina alterniflora*, plants isolated at 10–250 m from source populations.

Dispersal increases with population size or density. Cronin (2003) found that emigration of planthoppers, *P. crocea*, increased linearly with density of conspecific females.

Crowding increases the competition for resources, and may interfere with foraging or mating activity, thereby encouraging individuals to seek less crowded conditions. Leisnham and Jamieson (2002) reported that more mountain stone weta emigrated from large tors with larger demes, but proportionately more weta emigrated from small tors, probably reflecting the greater perimeter to area ratio of small tors.

The mating status of dispersing individuals determines their value as founders when they colonize new resources. Clearly, if unmated individuals must find a mate in order to reproduce after finding a habitable patch, their value as founders is negligible. For some species, mating occurs prior to the dispersal of fertilized females (R. Mitchell 1970). In species that are capable of parthenogenetic reproduction, fertilization is not required for dispersal and successful founding of populations. Some species ensure breeding at the site of colonization, by such means as long distance attraction via pheromones, e.g., by bark beetles (Raffa et al. 1993), or through males accompanying females on phoretic hosts, e.g., some mesostigmatid mites (Springett 1968) or mating swarms, e.g., eastern spruce budworm, *Choristoneura fumiferana* (Greenbank 1957).

Habitat conditions affect dispersal. Individuals are more likely to move greater distances when resources are scarce than when resources are abundant. Furthermore, the presence of predators may encourage emigration (Cronin et al. 2004). On the other hand, Seymour et al. (2003) found that a lycaenid butterfly, *Plebejus argus*, whose larvae are tended by ants, *Lasius niger*, apparently are able to orient toward patches occupied by *L. niger* colonies. Butterfly persistence in patches was influenced more strongly by ant presence than by floral resource density.

The dispersal mechanism determines the likelihood that individuals will reach a habitable patch. Individuals that disperse randomly have a low probability of colonizing a habitable destination. Larval settlement rates for black flies, *Simulium vittatum*, are lowest in the high stream velocity habitats preferred by the larvae, due to constraints on the ability of the larvae to control their direction of movement at high flow rates (D. Fonseca and Hart 2001). Conversely, individuals that can control their direction of movement and can orient toward cues which indicate suitable resources have a higher probability of reaching a habitable destination. Transportation by humans has substantially increased possibilities for long-distance dispersal across regional and continental barriers.

The capacity of individuals for long-distance dispersal is determined by their flight capacity, nutritional status, egg load, and parasitism. Winged insects disperse over greater distances than do wingless species (Leisnham and Jamieson 2002). Individuals feeding on adequate resources can store sufficient energy and nutrients to live longer and travel further than can individuals feeding on marginal or inadequate resources. Although dispersal should increase as population density increases, increased competition for food may limit individual energy reserves and endurance at high densities. Isaacs and Byrne (1998) reported that egg load was negatively correlated with height above ground for dispersing female sweet potato whiteflies, *Bemisia tabaci*, demonstrating a trade-off between dispersal and reproductive capacities for weak-flying insects. Furthermore, parasitized individuals may lose body mass more quickly during dispersal than do unparasitized individuals, and consequently exhibit shorter flight distances and slower flight speeds (Bradley and Altizer 2005). Hence, dispersal may peak before increasing density and disease reach levels that interfere with dispersal capacity (Leonard 1970, Schowalter 1985).

Dispersing individuals become vulnerable to new mortality factors. Whereas non-dispersing individuals may be relatively protected from temperature extremes and predation through selection of optimal microsites, dispersing individuals are exposed to ambient temperature

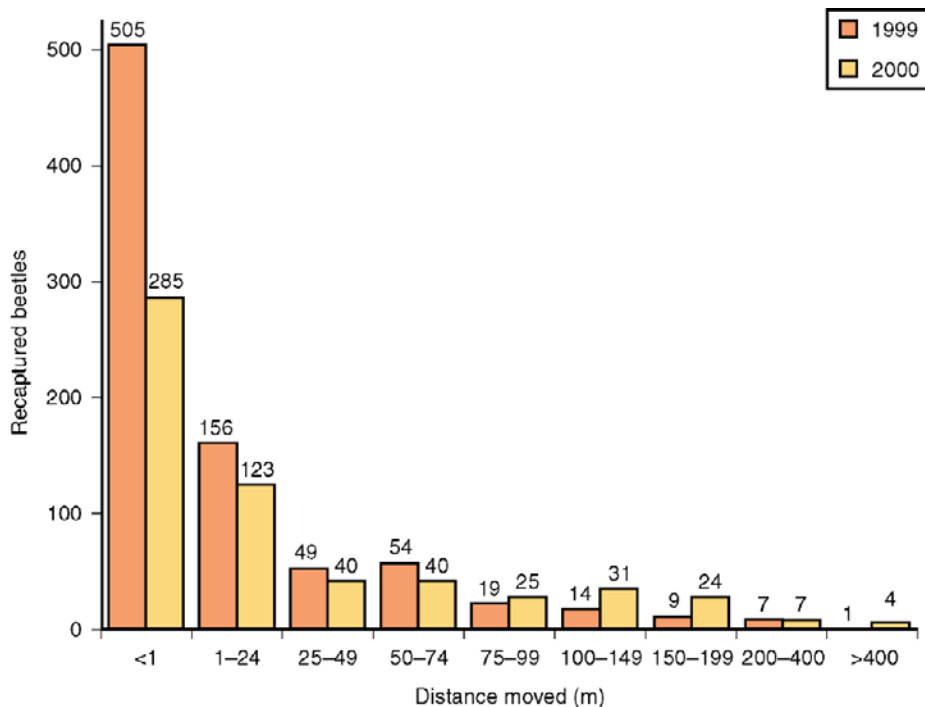
and humidity, high winds, and predators as they move across the landscape. Exposure to higher temperatures increases metabolic rate and depletes energy reserves more quickly, reducing the time and distance an insect can travel (Pope et al. 1980). Actively moving insects also are more conspicuous, hence more likely to attract the attention of predators (Schultz 1983). Dispersal across inhospitable patches may be inhibited or ineffective (Haynes and Cronin 2003). However, insects in patches with high abundance of predators may be induced to disperse as a result of frequent encounters with predators (Cronin et al. 2004).

The number of dispersing individuals declines with distance from the source population (Isaacs and Byrne 1998, St. Pierre and Hendrix 2003). The frequency distribution of dispersal distances often can be described by a negative exponential or inverse power law (Fig. 5.7). However, some species show a higher proportion of long-distance dispersers than would be expected from a simple diffusion model, suggesting heterogeneity in dispersal type (Cronin et al. 2000). A general functional model of dispersal ( $D$ ) can be described by the equation:

$$D = \frac{c}{2\alpha\Gamma(1/c)} \exp\left(-\frac{|X|^c}{|\alpha|}\right) \quad (5.1)$$

where  $X$ =distance,  $c$  and  $\alpha$  are shape and distance parameters, respectively, and  $\Gamma(1/c)$  is the gamma function (J. Clark et al. 1998, Nathan et al. 2003). The negative exponential ( $c = 1$ ) and Gaussian ( $c = 2$ ) are special cases of this formula. Similarly, effective dispersal declines as the probability of encountering inhospitable patches increases.

The contribution of dispersing individuals to the genetic heterogeneity of a population depends on a number of factors. The genetic heterogeneity of the source population



**FIG. 5.7** Range of dispersal distances from a population source for the weevil, *Rhysomatus lineaticollis* in Iowa, U.S. From St. Pierre and Hendrix (2003) by permission from the John Wiley & Sons.

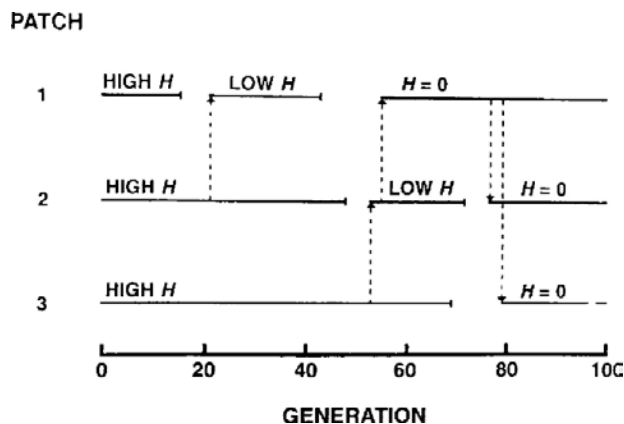
determines the gene pool from which dispersants come. Dispersing individuals represent a proportion of the total gene pool for that population. More heterogeneous demes contribute greater genetic heterogeneity of target or founded demes than do less heterogeneous demes (Fig. 5.8) (Hedrick and Gilpin 1997). The number or proportion of individuals that disperse affects their genetic heterogeneity. If certain genotypes are more likely to disperse, then the frequencies of these genotypes in the source population may decline, unless balanced by immigration.

Distances between demes influence the degree of gene exchange through dispersal. Local demes will be influenced more by the genotypes of dispersants from neighboring demes than by more distant demes. Gene flow may be precluded for sufficiently fragmented populations. This is an increasing concern for demes restricted to isolated refugia. Populations consisting of small, isolated demes may be incapable of sufficient interaction to sustain their viability. Gene flow also is affected by the habitat choices that are made by dispersing individuals (Edelaar et al. 2008). Individuals entering an area may show particular habitat preferences based on their phenotype or experience which restrict their interaction with other individuals that make different choices. Such “matching habitat choices” may limit gene flow among colonizing individuals and increase directed gene flow and speciation.

### III. LIFE HISTORY CHARACTERISTICS

Life history adaptation to environmental conditions typically involves complementary selection of natality and dispersal strategies that balance expected mortality. General life history strategies appear to be related to habitat stability and are crucial to the survival and growth of a population (Huryñ and Wallace 2000).

MacArthur and Wilson (1967) distinguished two life history strategies related to habitat stability and importance of colonization and rapid population establishment. The r-strategy generally characterizes “weedy” species that are adapted to colonize and dominate new or ephemeral habitats quickly (Janzen 1977). These species are opportunists that quickly colonize new resources, but they are poor competitors and cannot persist when competition increases in stable habitats. By contrast, the K-strategy is characterized by low rates



**FIG. 5.8** Simulated population heterozygosity ( $H$ ) over time in three habitat patches. Extinction is indicated by short vertical bars on the right end of horizontal lines; recolonization is indicated by arrows. From Hedrick and Gilpin (1997).

of natality and dispersal, but high investment of resources in storage and in individual offspring to ensure their survival. These species are adapted to persist under stable conditions, where competition is intense, but reproduce and disperse too slowly to be good colonizers. Specific characteristics of the two strategies (Table 5.1) have been the subject of debate (Boyce 1984). For example, small size with smaller resource requirements could reflect a K-strategy (Boyce 1984), although larger organisms typically show more efficient resource use. Nevertheless, this model has been useful for understanding selection of life history attributes (Boyce 1984).

Insects generally are considered to exemplify the r-strategy, because of their relatively short life spans, Type 3 survivorship, and rapid reproductive and dispersal rates. However, among insects, a wide range of r–K strategies have been identified. For example, low order streams (characterized by narrow constrained channels and steep topographic gradients) experience wider variation in water flow and substrate movement, compared to higher order streams (characterized by broader floodplains and shallower topographic gradients). Insects which are associated with lower order streams tend to be more r-selected than are those associated with slower water and greater accumulation of detritus (Reice 1985). Similarly, ephemeral terrestrial habitats, such as phytotelmata, are dominated by species which are capable of rapidly colonizing and completing development before the resource disappears or is degraded (Yee and Willig 2007). Many species which are associated with relatively stable habitats are poor dispersers, and are often flightless, even wingless, indicating weak selection for escape and colonization of new habitats (St. Pierre and Hendrix 2003). Such species may be at risk if environmental change increases the frequency of disturbance.

Grime (1977) modified the r–K model by distinguishing three primary life history strategies in plants, based on their relative tolerances to disturbance, competition, and stress. Clearly, these three factors are interrelated, since disturbance can affect competition and stress, and stress can increase vulnerability to disturbance. Nevertheless, this model has proven useful for distinguishing the following strategies, characterizing harsh vs. frequently disturbed and infrequently disturbed habitats.

**TABLE 5.1** Life history characteristics of species exemplifying the r- and K-strategies.

Attribute	Ecological Strategy	
	r (opportunistic)	K (equilibrium)
Homeostatic ability	Limited	Extensive
Development time	Short	Long
Life span	Short	Long
Mortality rate	High	Low
Reproductive mode	Often asexual	Sexual
Age at first brood	Early	Late
Offspring/brood	Many	Few
Broods/lifetime	Usually one	Often several
Size of offspring	Small	Large
Parental care	None	Extensive
Dispersal ability	High	Limited
Numbers dispersing	Many	Few
Dispersal mode	Random	Oriented

The **ruderal** strategy generally corresponds to the r-selected strategy and characterizes unstable habitats; the **competitive** strategy generally corresponds to the K-strategy and characterizes relatively stable habitats. The **stress-adapted** strategy characterizes species that are adapted to persist in harsh environments. These species are typically adapted to conserve resources and minimize their exposure to extreme conditions. Insects showing the stress-adapted strategy include those that are adapted to tolerate freezing in arctic ecosystems or to minimizing water loss in desert ecosystems (see Chapter 2).

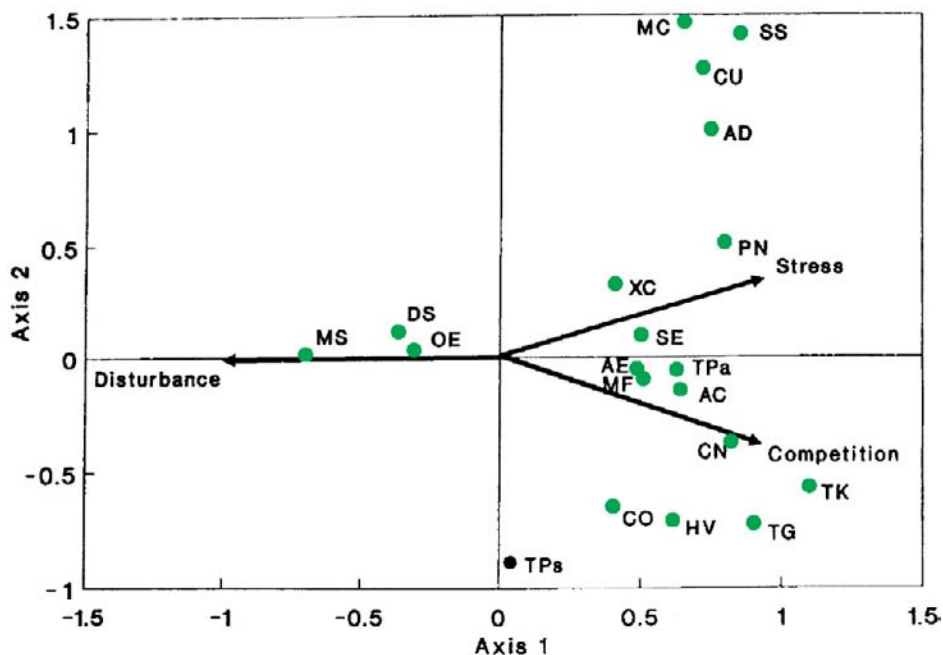
Fielding and Brusven (1995) explored correlations between plant community correspondence to Grime's (1977) strategies and the species traits (abundance, habitat breadth, phenology and diet breadth) of the associated grasshopper assemblages. They found that the three grasshopper species that were associated with the ruderal plant community had significantly wider habitat and diet breadths (generalists) and had higher densities than did grasshoppers associated with the competitive or stress-adapted plant communities (Fig. 5.9). Grasshopper assemblages also could be distinguished between the competitive and stress-adapted plant communities, but these differences were only marginally significant. Nevertheless, this study did suggest that insects can be classified according to Grime's (1977) model, based on their life history adaptations to disturbance, competition or stress.

#### IV. PARAMETER ESTIMATION

Whereas insect population structure can be measured by sampling the population, using various standard methods (Leather 2005, Southwood 1978), a sufficiently accurate estimation of population trends for management purposes requires the assessment of detection probability. Sampling techniques vary in their probability of detecting particular species. For example, light traps capture nocturnally-flying insects; branch bagging represents densities of leaf-miners and gall-formers missed by other sampling techniques but under-represents densities of highly mobile species (see Chapter 9). MacKenzie and Kendall (2002) described methods for addressing detection probability in assessment of population change. Estimates of natality, mortality and dispersal all require measurement of changes through time in overall rates of birth, death, and movement. A number of the methods used to estimate these population processes (Southwood 1978) are described below.

Fecundity can be estimated by measuring the numbers of eggs in dissected females or by recording the numbers of eggs laid by females caged under natural conditions. Fertility can be measured if the viability of eggs can be assessed. Natality then can be estimated from these data for a large number of females. Mortality can be measured by subtracting population estimates for successive life stages, by recovering and counting dead or unhealthy individuals, or by dissection or immunoassays to identify parasitized individuals. Dispersal capacity can be measured in the laboratory using flight chambers to record duration of tethered flight. Natality, mortality and dispersal also can be estimated from sequential recapture of marked individuals. However, these techniques require a number of assumptions about the constancy of natality, mortality and dispersal and their net effects on the population structure of the sample, and do not measure natality, mortality and dispersal directly.

Deevy (1947) was the first ecologist to apply the methods of actuaries, for determining life expectancy at a given age, to the development of survival and reproduction budgets



**FIG. 5.9** Constrained correspondence analysis ordination of grasshopper species in southern Idaho, using Grime's (1977) classification of life history strategies based on disturbance, competition, and stress variables (arrows). Grasshoppers are denoted by the initials of their genus and species. The length of arrows is proportional to the influence of each variable on grasshopper species composition. Eigenvalues for axes 1 and 2 are 0.369 and 0.089, respectively. From Fielding and Brusven (1995) with permission from the Entomological Society of America.

for animals. Life table analysis is the most reliable method to account for the survival and reproduction of a population (Begon and Mortimer 1981, Price 1997, Southwood 1978). The advantage of this technique over others is that survival and reproduction rates are accounted for in a way that allows for verification and comparison. For example, a change in cohort numbers due to disappearance of individuals, at a stage when dispersal cannot occur, could signal an error that requires correction, or causal factors that merit examination.

Two types of life table have been used widely by ecologists. The age-specific life table is based on the fates of individuals in a real cohort, i.e., a group of individuals born in the same time interval, whereas a time-specific life table is based on the fate of individuals in an imaginary cohort derived from the age structure of a stable population with overlapping generations, at a given point in time. Because most insects have discrete generations and unstable populations, the age-specific life table is more applicable than the time-specific life table.

Life tables analysis begins with designation of a cohort (Table 5.2). For simplicity, the starting size of the cohort generally is converted to a convenient number; generally 1 or 1000 females. Females are the focus of life table budgets because of their reproductive potential. Data from many cohorts representing different birth times, population densities, and environmental conditions should be analyzed and compared to gain a broad view of natality and mortality over a wide range of conditions.



Life tables partition the life cycle into discrete time intervals or life stages (Table 5.2). The age of females at the beginning of each period is designated by  $x$ , the proportion of females surviving at the beginning of the period (or age-specific survivorship) by  $l_x$ , and the number of daughters produced by each female surviving at age  $x$  (or age-specific reproductive rate) by  $m_x$ . Age-specific survivorship and reproduction can be compared between life stages to reveal patterns of mortality and reproduction. The products of per capita production and proportion of females surviving for each stage ( $l_x \cdot m_x$ ) can be added to yield the net production, or net replacement rate ( $R_0$ ), of the cohort. Net replacement rate indicates population trend. A stable population has  $R_0 = 1$ , an increasing population has  $R_0 > 1$ , and a decreasing population has  $R_0 < 1$ . These measurements can be used to describe population dynamics, as discussed in the next chapter.

The intensive monitoring necessary to account for survival and reproduction permits identification of the factors that affect survival and reproduction. Mortality factors, as well as numbers of immigrants and emigrants are conveniently identified and evaluated.

**TABLE 5.2** Examples of life tables. Note that in these examples, the same or different cohort replacement rates are obtained by the way in which per capita production of offspring is distributed among life stages.

$x$	$l_x$	$m_x$	$l_x m_x$
0	1.0	0	0
1	0.5	0	0
2	0.2	6	1.2
3	0.1	0	0
4	0	0	0
			1.2 = $R_0$
0	1.0	0	0
1	0.5	0	0
2	0.2	0	0
3	0.1	12	1.2
4	0	0	0
			1.2 = $R_0$
0	1.0	0	0
1	0.5	0	0
2	0.2	0	0
3	0.1	6	0.6
4	0	0	0
			0.6 = $R_0$

$x$ , life stage;  $l_x$ , proportion surviving at  $x$ ;  $m_x$ , per capita production at  $x$ ; and  $l_x m_x$ , net production at  $x$ . The sum of  $l_x m_x$  is the replacement rate,  $R_0$ .

Survivorship between cohorts can be modeled as a line with a slope of  $-k$ . This slope variable can be partitioned among factors affecting survivorship, i.e.,  $-k_1, -k_2, -k_3, \dots -k_i$ . Such K-factor analysis has been used to assess the relative contributions of various factors to survival or mortality (e.g., Curry 1994, Price 1997, Varley et al. 1973). The factors that have the greatest effect on survival and reproduction are designated **key factors**, and they may be useful in population management. For example, key mortality agents can be augmented for control of pest populations or mitigated for recovery of endangered species.

Measurement of insect movement and dispersal is necessary for a number of objectives (Nathan et al. 2003, Turchin 1998). Disappearance of individuals due to emigration must be distinguished from mortality for life table analysis and assessment of effective dispersal. Movement affects the probability of contact among organisms, determining their interactions. Spatial redistribution of organisms determines population structure, colonization, and metapopulation dynamics (see also Chapter 7). Several methods for measuring and modeling animal movement have been summarized by Nathan et al. (2003) and Turchin (1998). Most of these are labor intensive, especially for insects.

Effective dispersal can be reconstructed from biogeographic distributions, especially for island populations that must have been founded from mainland sources. This method does not reveal the number of dispersing individuals required for successful colonization.

Mark–recapture methods involve marking a large number of individuals and measuring their frequency in traps or observations at increasing distance from their point of release. Several methods can be used to mark individuals. Dyes, stable isotopes and rare element incorporation through feeding or dusting provide markers that can be used to distinguish marked individuals from others in the recaptured sample. Some populations are self-marked by incorporation of rare earth elements or other markers unique to their birthplace or overwintering site (e.g., Isaacs and Byrne 1998).

Large numbers of insects must be marked in order to maximize the probability of recapture at large distances. Schneider (1999) marked ca. 7,000,000 adult *Heliothis virescens* using an internal dye, released the moths at multiple sites over a 238 km<sup>2</sup> area and then trapped them by using pheromones at sites representing a 2000 km<sup>2</sup> area. Mean dispersal distances of male moths was ca. 10 km.

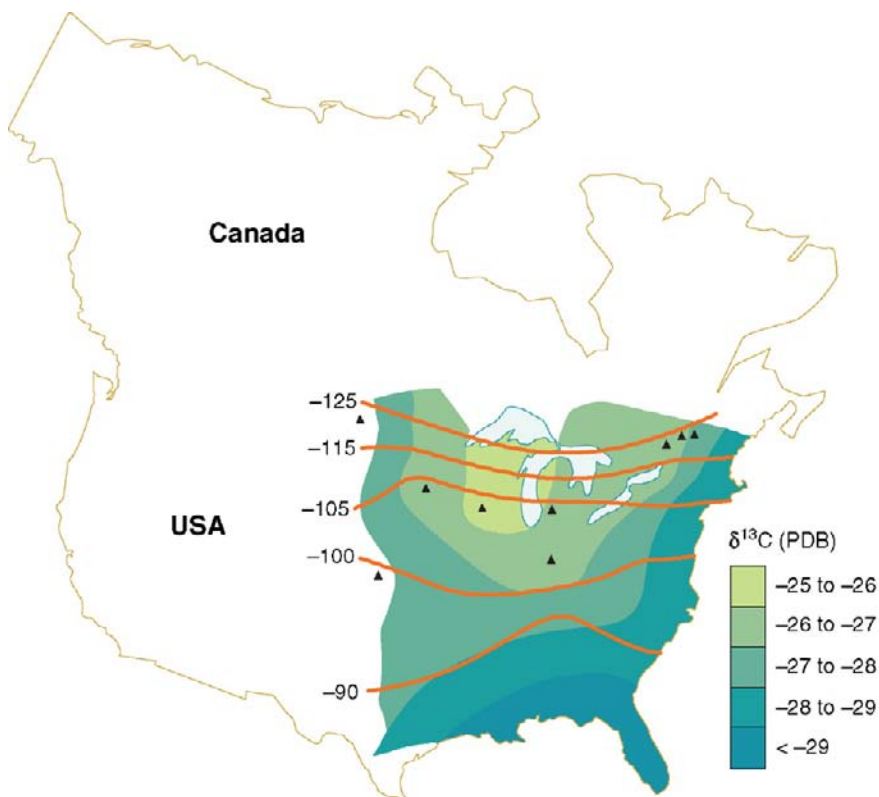
Leisnham and Jamieson (2002) used mark–recapture techniques to estimate immigration and emigration rates for mountain stone weta demes among large and small tors in southern New Zealand. They found that the per capita immigration rate on large tors (0.019) slightly exceeded the emigration rate (0.017), whereas the immigration rate on small tors (0.053) was lower than the emigration rate (0.066), explaining the greater tendency for extinction of demes on small tors (4 out of 14 over a 3 year study, compared to no extinctions among 4 large tors).

Wassenaar and Hobson (1998) used stable isotopes (<sup>2</sup>H and <sup>13</sup>C) to identify the Midwestern U.S. as the source of most monarch butterflies, *Danaus plexippus*, that were overwintering at sites in Mexico (Fig. 5.10). Cronin et al. (2000) reported that 50% of marked checkered beetles, *Thanasimus dubius*, moved at least 1.25 km, 33% moved > 2 km, and 5% dispersed by > 5 km, whereas 50% of their primary prey, the southern pine beetle, moved no more than 0.7 km and 95% moved no more than 2.25 km. St. Pierre and Hendrix (2003) demonstrated that 56% of recaptured weevils, *Rhysomatus lineaticollis*, moved <1 m and 83% moved <50 m. This method can indicate the distances which have been moved by individuals, but does not indicate the path, which requires direct observation.

Direct observation has limited value for rapidly moving individuals, although marking them in various ways can enhance detection at greater distances. New technology has provided for miniaturization of radio, harmonic radar or microwave transmitters or tags that can be used with a receiver to record the location of an individual continuously or at intervals (e.g., J. Riley et al. 1996, Lorch et al. 2005). However, marking and electronic signaling methods could affect the behavior of tagged individuals, requiring evaluation of any effects on individual behavior (Lorch et al. 2005).

New genetic techniques permit the identification of the source population of dispersing individuals. However, a large number of source individuals must be genotyped in order to distinguish allelic frequencies of multiple sources. Dispersal frequency also may be measured in some cases by taking advantage of relationships between genetic differentiation and distance between demes.

A major challenge to future measurement of dispersal is the increasing homogenization of biotas by human-assisted invasion (e.g., Mack et al. 2000). A. Suarez et al. (2001) evaluated dispersal of Argentine ants, *Linepithema humile*, at three spatial scales, local, regional and global, based on documented rates of spread. They discovered that these ants have two discrete dispersal modes, diffusion and jump dispersal. Local diffusion occurs at a maximum rate of  $150 \text{ m yr}^{-1}$ , whereas jump dispersal resulted in annual rates



**FIG. 5.10** Geographic patterns of  $\delta^2\text{H}$  and  $\delta^{13}\text{C}$  in wings of monarch butterflies from rearing sites (triangles) across the breeding range in North America. From Wassenaar and Hobson (1998) with permission from the National Academy of Sciences.

of spread  $> 160 \text{ km yr}^{-1}$ , driven largely by association with humans. As species become more widespread, the source of particular populations will become more difficult to assess.

## V. SUMMARY

Population systems can be described in terms of structural variables and processes that produce changes in population structure. These variables indicate population status and capacity for change in response to environmental heterogeneity.

Structural variables include density, dispersion pattern of individuals and demes, age structure, sex ratio and genetic composition. Density is the number of individuals per unit area. Dispersion is a measure of how populations are distributed in space. Regular dispersion occurs when organisms are spaced evenly among habitat or sampling units. Aggregated dispersion occurs when individuals are found in groups, for mating, mutual defense or resource exploitation, or because of the distribution of resources. Random dispersion occurs when the locations of organisms are independent of the locations of others. Metapopulation structure describes the distribution and interaction among relatively distinct sub-populations, or demes, occurring among habitable patches over a landscape. The degree of isolation of demes influences the gene flow among demes and the ability of a population to colonize or recolonize vacant patches. Age structure represents the proportion of individuals in each age class and can indicate survivorship patterns or direction of change in population size. Sex ratio is the proportion of males in the population and indicates the importance of sexual reproduction, the mating system, and capacity for reproduction. Genetic composition is described by the frequencies of various alleles in the population and reflects the capacity of the population to adapt to environmental change. Some insect populations have been shown to change gene frequencies within relatively short times in response to strong directional selection, due to their short generation times and high reproductive rates. This capacity for rapid change in gene frequencies makes insects especially capable of adapting to anthropogenic changes in environmental conditions.

Processes that produce change in population structure include natality, mortality, and dispersal. Natality is birth rate and represents the integration of individual fecundity and fertility. It is affected by abundance and nutritional quality of food resources, as well as abundance and suitability of oviposition sites, the availability of males, and population density. Mortality is death rate and reflects the influence of various mortality agents, including extreme weather conditions, food quality, competition, and predation. Generally, predation has a greater effect at low to moderate densities, whereas competition has a greater effect at high densities. Survivorship curves indicate three types of survivorship, based on whether mortality is consistent or concentrated near the beginning or end of the life span. Dispersal is the movement of individuals from a source, and is a key to genetic mixing and colonization of vacant patches. Individuals that colonize vacant patches have a considerable influence on the genetic composition and development of the deme.

Life history strategies reflect the integration of natality, mortality and dispersal strategies selected by habitat stability. Two life history classifications have been widely used. Both reflect the importance of disturbance and environmental stress on the evolution of complementary strategies for reproduction and dispersal in harsh, stable or unstable habitats.

Whereas population structure can be described readily by sampling the population, measurement of population processes is more difficult and requires accounting for the fate of individuals. Life table analysis is the most reliable method to account for age-specific survival and reproduction by members of a cohort. The net production of offspring by the cohort is designated the replacement rate and indicates population trend. Advances in technology are creating new opportunities to explore patterns and efficiency of long distance dispersal. Changes in these variables and processes are the basis for population dynamics. Regulatory factors and models of population change in time and space are described in the next two chapters.

# Population Dynamics

- I. Population Fluctuation
- II. Factors Affecting Population Size
  - A. Density Independent Factors
  - B. Density Dependent Factors
  - C. Regulatory Mechanisms
- III. Models of Population Change
  - A. Exponential and Geometric Models
  - B. Logistic Model
  - C. Complex Models
  - D. Computerized Models
  - E. Model Evaluation
- IV. Summary

## Rise and fall of a cotton herbivore

Insect populations are noted for their dramatic fluctuations in size and often have been targets for control efforts. However, species which are characterized by periodic outbreaks will typically decline to very low numbers as a result of resource depletion and increased predation and parasitism. If population size falls below a critical minimum threshold, males and females may be unable to find each other to reproduce, leading to extinction.

The cotton leafworm, *Alabama argillacea*, was once the most economically important pest of cotton in the Americas and among the most abundant migratory insects in eastern North America (D.L. Wagner 2009). This moth was a specialized herbivore on cotton, *Gossypium* spp. and its close relatives, in Central and South America. It appeared in the U.S. in 1793, causing serious losses to cotton crops in Georgia and South Carolina, and again in 1800 (C. Riley 1885). During the next four years it spread through the range of commercial cotton in the southern U.S., with particularly devastating outbreaks in 1804, 1825, 1846, 1868, 1873, and 1881, and became among the earliest targets of mechanically-applied, arsenical insecticides (C. Riley 1885).

This species was not, however, a permanent resident of the U.S. Cotton Belt. It apparently did not have a freeze-tolerant diapause or quiescent stage, so was capable of continuous breeding only in the subtropical and tropical portions of its range. However, it reproduced rapidly and often migrated as massive swarms into temperate regions during spring and summer, depending on environmental conditions, and then reproduced and caused crop damage in the Cotton Belt. The size of migrating swarms reflected particular environmental conditions and source population size. As a result, swarms often reached the U.S. Cotton Belt after harvest, and most records of the moth in the northern U.S. are from September–October (D.L. Wagner 2009).

Cotton production in the U.S. declined in the early 1900s, as a result of devastation by the boll weevil, *Anthonomus grandis* (R.H. Smith 2007), and agriculture in the region became much more diverse. The cotton leafworm declined in abundance during this period and apparently became extinct by the late 1900s, probably as a result of reduced cotton acreage and more intense pest management of cotton (D.L. Wagner 2009).

## INTRODUCTION

POPULATIONS OF INSECTS CAN CHANGE DRAMATICALLY IN SIZE OVER relatively short periods of time, given their short generation times and high reproductive rates. Since the beginning of the agricultural age, humans have dealt with plagues of locusts and flies that seemed to come from nowhere to destroy virtually all vegetation or torment humans and livestock over extensive areas. Such views supported early concepts of “Acts of God” and “spontaneous generation” (C. Riley 1883).

C. Riley (1878, 1880, 1883, 1885) was among the first to document the periodic irruptive behavior of insects and relate outbreaks to changes in environmental conditions. Under favorable environmental conditions, some species have the capacity to increase their population size by several orders of magnitude in a few years. A swarm of Rocky Mountain grasshoppers, *Melanoplus spretus*, flying over Lincoln, Nebraska on June 16, 1875, a peak year, was estimated to include at least 125 billion locusts covering more than 23,000 km<sup>2</sup> (C. Riley 1878). This was the largest congregation of animals ever recorded (Lockwood 2001), although more accurate, and credible, measurements of locust swarm sizes awaited the advances in aerial surveillance that came in the mid 20th century (Gunn et al. 1948, Rainey and Sayer 1953, Uvarov 1954). Under adverse conditions, populations can virtually disappear for long time periods or become extinct. Devastating outbreaks have brought insects into direct conflict with humans, but also have supported focused entomological research that has expanded our understanding of the factors that affect insect population dynamics and, more recently, the effects of insects on ecosystem conditions and services. Consequently, methods and models for describing population change are the most developed for economically important insects.

Predicting the effects of global change has become a major goal of research on population dynamics. Insect populations respond to changes in habitat conditions and resource quality (Heliövaara and Väisänen 1993, Lincoln et al. 1993, Chapter 2). Their responses to current and historic environmental changes help us to anticipate their responses in the future. Disturbances, in particular, influence population systems abruptly, but these effects are integrated by changes in natality, mortality, and dispersal rates. Factors that normally regulate population size, such as resource availability and predation, also are affected by disturbance. Models of population change generally do not incorporate effects of disturbance. This chapter addresses temporal patterns of abundance, factors causing or regulating population fluctuation, and models of population dynamics.

## I. POPULATION FLUCTUATION

Insect populations can fluctuate dramatically over time. Some insects have long records of fluctuation, including 1173 years for the larch budmoth, *Zeiraphera diniana*, in the European Alps (Esper et al. 2007), 1000 years for the oriental migratory locust, *Locusta migratoria manilensis*, in China (Konishi and Itô 1973, Ma 1958), and 622 years for the Pandora moth, *Coloradia pandora*, in western North America (Speer et al. 2001). Such

long records are enormously useful for identifying the environmental factors responsible for population change. If environmental conditions change in a way that favors insect population growth, the population will increase until regulatory factors reduce and finally stop population growth rate.

Some populations can vary in density as much as  $10^5$ -fold (Mason 1996, Mason and Luck 1978, Royama 1984, Schell and Lockwood 1997), but most populations vary less than this (Berryman 1981, D. Strong et al. 1984). The amplitude and frequency of population fluctuations can be used to describe three general patterns. Stable populations fluctuate relatively little over time whereas irruptive and cyclic populations show wide fluctuations.

Irruptive populations sporadically increase to peak numbers followed by a decline. Certain combinations of life history traits may be conducive to irruptive fluctuation. Larsson et al. (1993) and Nothnagle and Schultz (1987) identified differences in life history attributes between irruptive and non-irruptive species of sawflies and Lepidoptera from European and North American forests. Irruptive species generally are controlled by only one or a few factors, especially drought (Konishi and Itô 1973, Mattson and Haack 1987, Priesser and Strong 2004), whereas populations of non-irruptive species are controlled by many factors. In addition, irruptive Lepidoptera and sawfly species tend to be gregarious, have a single generation per year, and are sensitive to changes in quality or availability of their particular resources, whereas non-irruptive species do not share this combination of traits.

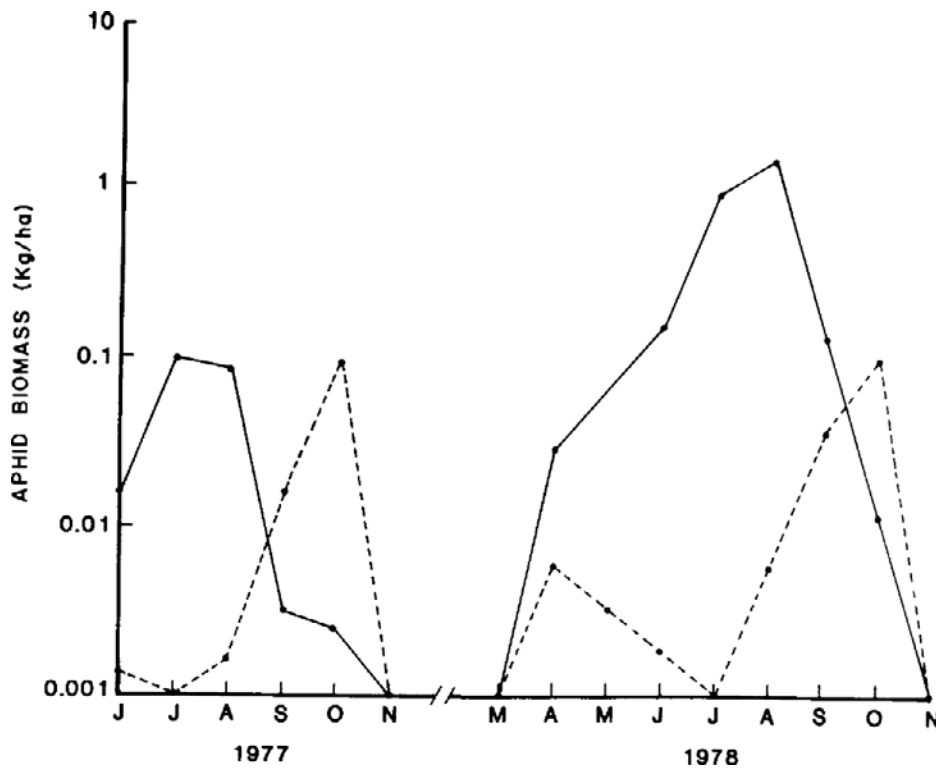
Cyclic populations oscillate at regular intervals. Cyclic patterns of population fluctuation have generated the greatest interest among ecologists. They can be seen over different time scales and may reflect a variety of interacting factors.

Strongly seasonal cycles of abundance can be seen for multivoltine species such as aphids and mosquitoes. Aphid population size is correlated with periods of active nutrient translocation by host plants (Dixon 1985) and is influenced by mid-season increases in predation (Karley et al. 2004). Hence, populations of most aphid species peak in the spring when nutrients are being translocated to new growth, followed by collapse to local extinction during mid-summer. Populations of many species (especially those feeding on deciduous hosts) increase again in the fall when nutrients are being resorbed from senescing foliage. This pattern can be altered by disturbance. Schowalter (1985) reported that sustained growth of early successional vegetation following clearcutting of a deciduous forest supported continuous growth of aphid populations during the summer (Fig. 6.1). Seven dominant mosquito species in Florida during 1998–2000 showed peak abundances at different times of the year, but the interannual pattern varied as a result of particular environmental conditions, including flooding (Zhong et al. 2003).

Longer term cycles are apparent for many species. Several forest Lepidoptera exhibit cycles with periods of ca. 10, 20, 30, or 40 yrs (Berryman 1981, Esper et al. 2007, Mason and Luck 1978, Price 1997, Royama 1992, Swetnam and Lynch 1993), or combinations of cycles (Speer et al. 2001). For example, the larch budmoth has shown outbreaks every 9.3 yrs, on average, over a 1173 yr period in the European Alps (Fig. 6.2), and spruce budworm, *Choristoneura fumiferana*, populations have peaked at approximately 25–30 yr intervals over a 250 yr period in eastern North America (Royama 1984), whereas Pandora moth populations have shown a combination of 20 and 40 yr cycles over a 622 yr period in western North America.

Explanations for cyclic population dynamics include climatic cycles and changes in insect gene frequencies or behavior, food quality, or susceptibility to disease that occur

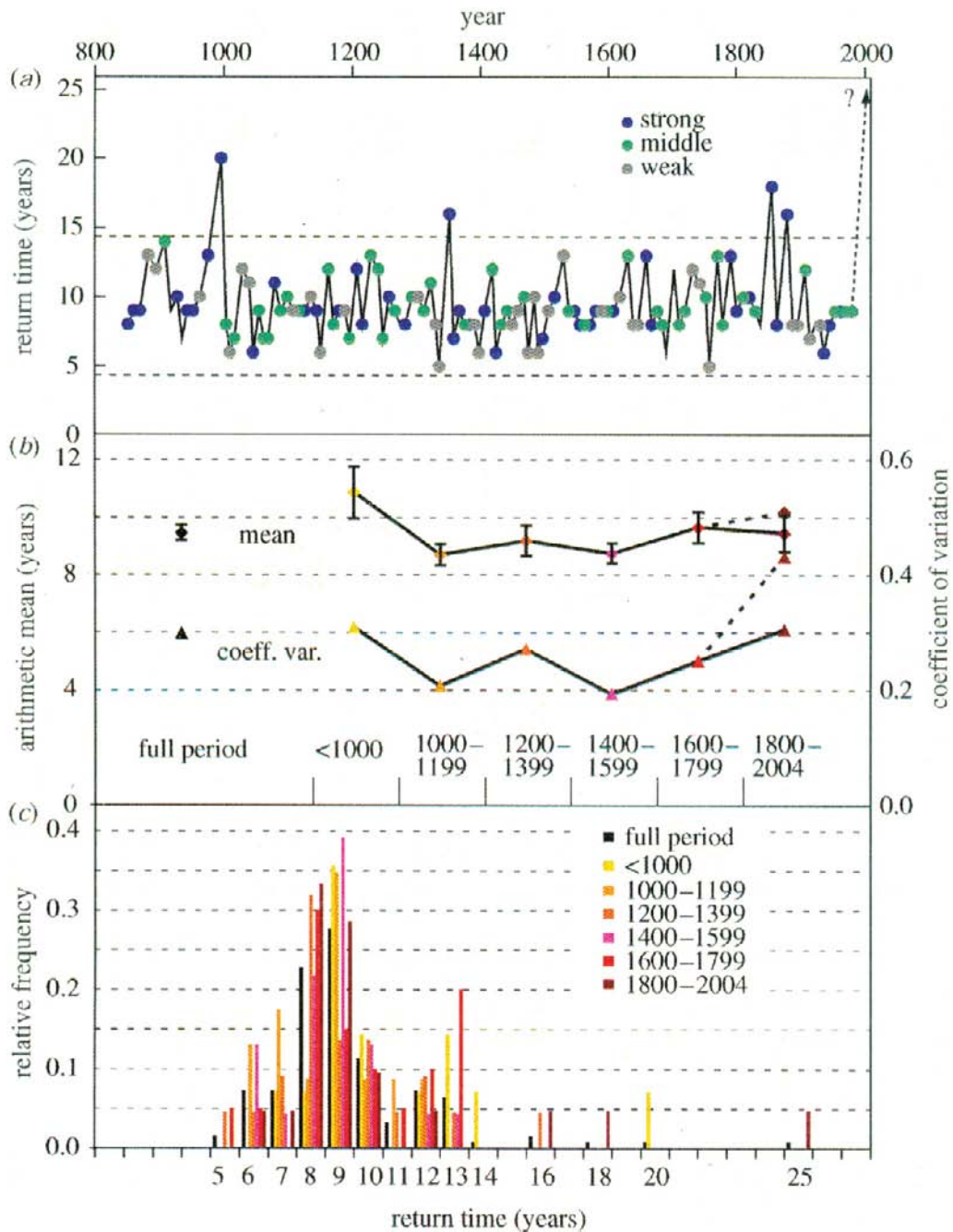




**FIG. 6.1** Seasonal trends in aphid biomass in an undisturbed (dotted line) and an early successional (solid line) mixed-hardwood forest in North Carolina. The early successional forest was clearcut in 1976–77. Peak abundances in spring and fall on the undisturbed watershed reflect nutrient translocation during periods of foliage growth and senescence; continued aphid population growth during the summer on the disturbed watershed reflects the continued production of foliage by regenerating plants. From Schowalter (1985).

during large changes in insect abundance (J. Myers 1988). Climatic cycles may trigger insect population cycles directly through changes in mortality or indirectly through changes in host condition or susceptibility to pathogens. However, regular irruptions of *Z. dini-ana* have occurred for over 1000 years in the European Alps independently of long-term warming and cooling trends (Esper et al. 2007). Depletion of food resources during an outbreak may impose a time lag for the depleted resources to recover to levels which are capable of sustaining renewed population growth (e.g., W. Clark 1979). Epizootics of entomopathogens may occur only above threshold densities. High genetic heterogeneity for disease resistance can lead to intense selection for resistance during disease-driven population collapse, followed by increased infection risk during population growth due to the cost of resistance (Elder et al. 2008). Sparse populations near their extinction threshold (see below) may require several years to recover sufficient numbers for rapid population growth. Berryman (1996), Royama (1992), Turchin (1990) and Turchin et al. (1999) have demonstrated the importance of delayed effects (time lags) of regulatory factors (especially predation or parasitism) to the generation of cyclic pattern.

For some insects, especially Lepidoptera, population cycles are synchronized over large areas, up to 1200 km apart (i.e., at a continental scale), suggesting the influence of



**FIG. 6.2** Cyclic behavior of larch budmoth, *Zeiraphera diniana*, populations over a 1173 yr period (832–2004). *a*) Return time record for 123 outbreak events, with colors indicating the severity of outbreaks, measured as reduction in wood density caused by defoliation. The dashed line at the end of the 20th century reflects the absence of outbreaks since 1981. The horizontal dashed lines represent two standard deviations. *b*) Arithmetic mean and standard error (bars), and coefficient of variation computed for the full return time record and six subperiods. Dashed lines in recent centuries reflect the absence of outbreaks since 1981. *c*) Relative frequency distribution of return times. Colors indicate different time periods. Single events can be represented by bars of different relative heights (e.g., all bars in classes above 14 years are single events). From Esper et al. (2007) with permission from the authors and the Royal Society.

a common widespread trigger such as climate, sunspot, lunar, or ozone cycles (W. Clark 1979, D. Johnson et al. 2005, Liebhold et al. 2004, Økland et al. 2005, Price 1997, Royama 1984, 1992, Speer et al. 2001). P. Moran (1953) suggested, and Royama (1992) demonstrated (using models), that synchronized cycles could result from correlations among controlling factors. Liebhold et al. (2004) found that synchrony arises from three primary mechanisms: a) dispersal among demes transfers individuals from growing demes to smaller demes, b) congruent dependence of multiple demes on exogenous synchronizing factors, such as temperature or precipitation (the “Moran” effect), and c) trophic interactions with other species that integrate demes via mortality (see Chapter 9).

Raimondo et al. (2004) reported that generalist predators could explain the observed synchronous population dynamics of multiple prey species. On the other hand, the synchronous emergence of periodical cicadas, *Magicicada* spp., was found to synchronize abundances of 15 of 37 bird species evaluated by Koenig and Liebhold (2005). Bird populations sharing the same cicada brood showed greater intraspecific spatial synchrony than did bird populations in the ranges of different cicada broods. Liebhold et al. (2006) used simulation modeling to demonstrate that geographic variation in direct and delayed density-dependence diminished synchrony that resulted from stochastic forcing by geographic variation, but not that resulting from dispersal processes. Hence, the cause of the synchrony can be independent of the cause of the cyclic pattern of fluctuation.

Generally, peak abundances are maintained only for a few (2–5) years, followed by relatively precipitous declines (Fig. 6.2). Changes in population size can be described by four distinct phases (Mason and Luck 1978). The **endemic phase** is the low population level maintained between outbreaks. The beginning of an outbreak cycle is triggered by a disturbance, release from predation or other environmental change that allows the population to increase in size above its **release threshold**. This threshold represents a population size at which reproductive momentum results in escape of at least a portion of the population from normal regulatory factors, such as predation. Despite the importance of this threshold to population outbreaks, few studies have established its size for any insect species. Schowalter et al. (1981b) reported that local outbreaks of southern pine beetle, *Dendroctonus frontalis*, occurred when demes reached a critical size of about 100,000 beetles by early June. Above the release threshold, survival is relatively high and population growth continues during the **release phase**. During this period, the rate of emigration peaks, and the population spreads to other suitable habitat patches (see Chapter 7). Resources eventually become limiting, as a result of depletion by the growing population, and predators and pathogens respond to increased prey/host density and stress. Population growth slows, and abundance reaches a **peak**. Competition, predation and pathogen epizootics initiate, and accelerate population **decline**. Intraspecific competition and predation rates then decline as the population re-enters the endemic phase.

Outbreaks of some insect populations have become more frequent and intense in crop systems or natural monocultures where food resources are relatively unlimited or where manipulation of disturbance frequency has created favorable conditions (e.g., Heiermann and Schütz 2008, Kareiva 1983, Raffa et al. 2008, Wickman 1992). In other cases, the frequency of recent outbreaks has remained within the documented ranges for frequencies of historic outbreaks, but the extent or severity has increased as a result of anthropogenic changes in vegetation structure or disturbance regime (Speer et al. 2001).

Populations of many species fluctuate at amplitudes that are insufficient to cause economic damage and, therefore, do not attract attention. Some of these species may experience more conspicuous outbreaks under changing environmental conditions, e.g., climate

change, introduction into new habitats, or large-scale conversion of natural ecosystems to managed ecosystems (e.g., Mattson and Haack 1987, Van Bael et al. 2004, D. Williams and Liebhold 2002). The Colorado potato beetle, *Leptinotarsa decemlineata*, subsisted on wild solanaceous hosts in western North America until westward movement of settlers brought it into contact with the cultivated potato in the Midwest during the late 1800s (Hitchner et al. 2008, C. Riley 1883, Stern et al. 1959), allowing it to spread eastward and, eventually, to Europe. Similarly, the cotton boll weevil, *Anthonomus grandis*, co-evolved with scattered wild *Gossypium spp.*, including *Gossypium hirsutum*, in tropical Mesoamerica, until citrus cultivation in the 1890s provided overwintering food resources that allowed the insect to spread into the subtropical cotton-growing regions of south Texas and northern Argentina (Showler 2009). Subsequently, rapid reproduction in the spring by overwintering adults permitted spread throughout the U.S. Cotton Belt (Showler 2009).

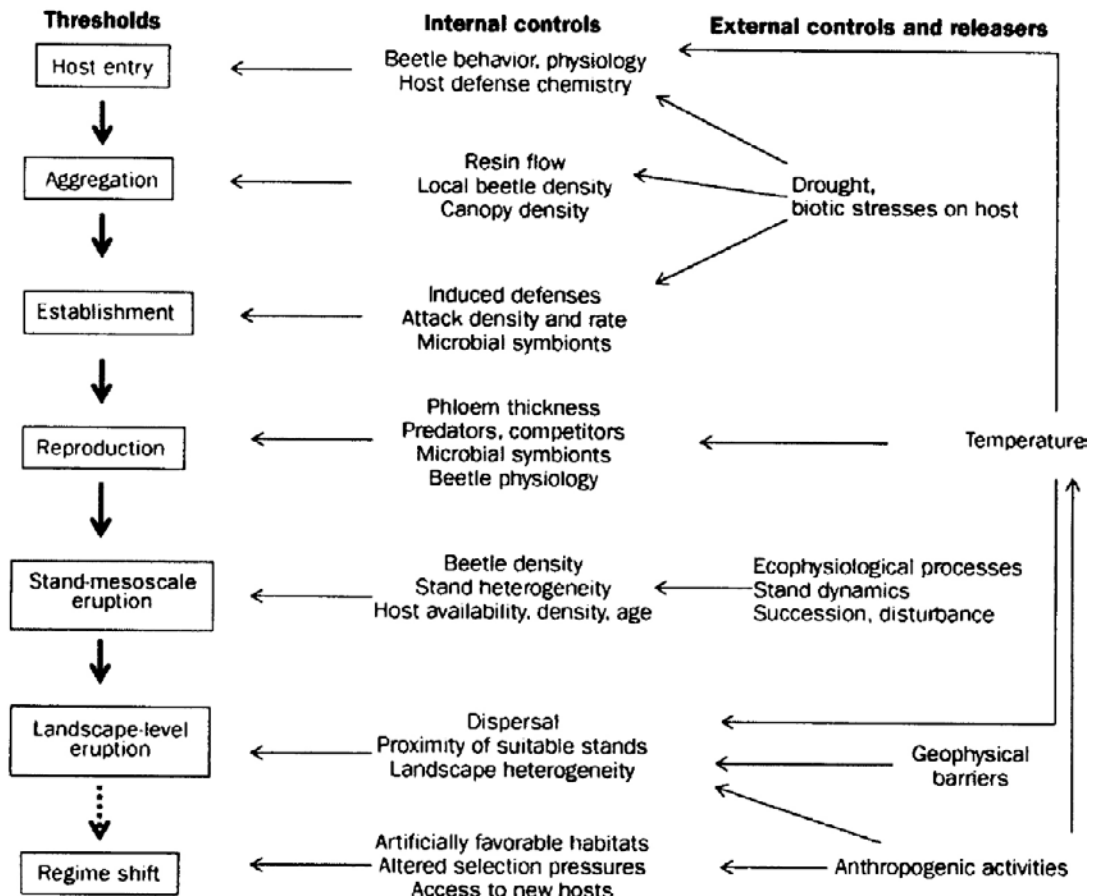
## II. FACTORS AFFECTING POPULATION SIZE

Populations showing wide amplitude of fluctuation have weak intrinsic ability to regulate growth, e.g., through depressed natality in response to crowding or competition. Population outbreaks may represent the cumulative effects of many factors that permit population growth above successive thresholds (Fig. 6.3). These factors can influence population size in two primary ways. If the proportion of organisms affected by a factor is constant for any population density, or the effect of the factor does not depend on population density, the factor is considered to have a **density-independent** effect. Conversely, if the proportion of organisms affected varies with density, or the effect of the factor depends on population density, then the factor is considered to have a **density-dependent** effect (Begon and Mortimer 1981, Berryman 1981, L. Clark et al. 1967, Price 1997, Raffa et al. 2008).

The distinction between density independence and density dependence is often confused, for various reasons. First, many factors may act in both density-independent and density-dependent manners, depending on circumstances. For example, climatic factors or disturbances often are thought to affect populations in a density-independent manner, because the same proportion of exposed individuals typically is affected at any population density. However, if shelter from unfavorable conditions is limited, the proportion of individuals exposed (and, therefore, the effect of the climatic factor or disturbance) may be related to population density. A plant defense may have a density-independent effect until herbivore densities reach a level that triggers induced defenses. Therefore, a particular factor may have a density-independent effect over one range of population densities and a density-dependent effect over another range of densities. Generally, population size is modified by abiotic factors, such as climate and disturbance, but maintained near an equilibrium level (regulated) by density-dependent biotic factors.

### A Density Independent Factors

Insect populations are highly sensitive to changes in abiotic conditions, such as temperature, water availability, etc., which affect insect growth and survival (see Chapter 2). Changes in population size of some insects have been related directly to changes in climate or to disturbances (e.g., Greenbank 1963, Kozár 1991, E. Porter and Redak 1996, Reice 1985). In some cases, climate fluctuation or disturbance affects resource values for insects. For example, loss of riparian habitat as a result of agricultural practices in western



**FIG. 6.3** Conceptual diagram of a sequence of thresholds (boxes) that must be exceeded, as a result of internal and external controlling factors, to produce a landscape-scale irruption of bark beetles. Thresholds progress from the individual (successful host entry) to population (aggregation, establishment, reproduction) to ecosystem (stand, landscape) levels. Major direct controls that influence the likelihood of beetles surpassing a particular threshold are shown in the middle column. External controls and releasers are shown in the right column. Anthropogenic activities constitute external releasers that facilitate breach of a previously unsurpassed threshold along this continuum into an altered regime state that can explain recent changes in the irruptive behavior of many insect species. From Raffa et al. (2008) with permission from the authors and the University of California Press—Journals.

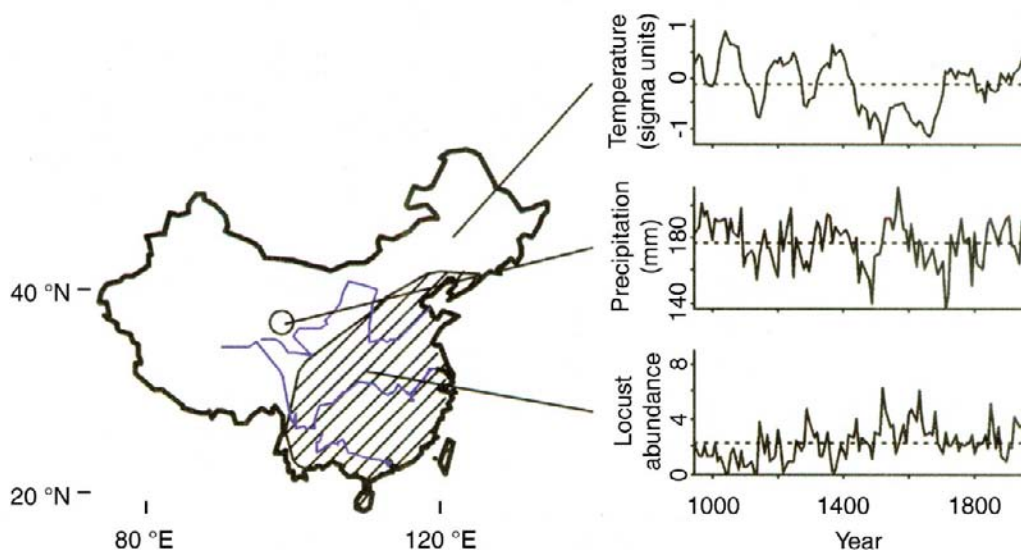
North America may have led to extinction of the historically important Rocky Mountain grasshopper, *M. spretus* (Lockwood 2001, Lockwood and DeBrey 1990).

Many environmental changes occur relatively slowly and cause gradual changes in insect populations as a result of subtle shifts in genetic structure and individual fitness. Other environmental changes occur more abruptly and may trigger rapid change in population size because of sudden changes in natality, mortality or dispersal. Esper et al. (2007) found that the larch budmoth, *Z. diniana*, has shown regular population outbreaks at 9 yr intervals for 1200 yrs, during warming and cooling climate periods, but its population has failed to increase since 1981, a period during which temperatures have increased above the historic range (Fig. 6.2). Disturbances are particularly important triggers for inducing population

change, because of their acute disruption of population structure and of resource, substrate and other ecosystem conditions. The disruption of population structure can alter community structure and cause changes in the physical, chemical and biological conditions of the ecosystem. Disturbances can promote or truncate population growth, depending on species tolerances to particular disturbance or post-disturbance conditions. Drought, in particular, has been identified as an important trigger for population irruptions of many species, including locusts, moths and bark beetles, promoted by host stress and crowding (Breshears et al. 2005, Konishi and Itô 1973, Mattson and Haack 1987, Priesser and Strong 2004, Schowalter et al. 1999, van Bael et al. 2004), but storm damage also increases resources for some insects (Hanewinkel et al. 2008, Schowalter and Ganio 2003).

Interestingly, locust outbreaks appear to be triggered by either drought or flooding disturbances. A 1000 yr record of locust outbreaks in China indicated that outbreaks typically originated in floodplain refuges, locations of adequate vegetation and suitable oviposition sites, during drought years and years after flooding (Stige et al. 2007). Droughts increase availability of suitable oviposition sites as water recedes, as well as stressed vegetation, whereas similar conditions occur in formerly flooded areas in the year after flooding (Fig. 6.4).

Some species are more tolerant of particular disturbances, on the basis of their adaptation to regularly recurring disturbances. For example, plants in fire-prone ecosystems show attributes that protect meristematic tissues, whereas those in frequently flooded ecosystems can tolerate root anaerobiosis. Generally, insects do not have specific adaptations to survive disturbance, given their short generation times relative to disturbance intervals, and unprotected populations may be greatly reduced. Species that do show disturbance-adapted traits, such as orientation to smoke plumes or avoidance of litter



**FIG. 6.4** One thousand years of locust abundance and climate data from China. The present distribution of *Locusta migratoria manilensis* is shown by hatched lines on the map. Large rivers, blue lines, from north to south are the Yellow, Yangtze and Pearl. Temperature data are a composite index for all of China. Precipitation data are from northeastern Qinghai (circle). Locust data are for all of China. From Stige et al. (2007) with permission from the National Academy of Science, USA.

accumulations in fire-prone ecosystems (W. Evans 1966, K. Miller and Wagner 1984), generally have longer (2–5 yr) generation times, which increases the frequency of generations that experience a disturbance. Most species are affected by post-disturbance conditions. Disturbances affect insect populations both directly and indirectly.

Disturbances create lethal conditions for many insects. For example, fire can burn exposed individuals (Porter and Redak 1996, P. Shaw et al. 1987) or raise temperatures to lethal levels in unburned microsites. Tumbling cobbles in flooding streams can crush benthic insects (Reice 1985). Flooding of terrestrial habitats can create anaerobic soil conditions. Drought can raise air and soil temperatures and cause desiccation (Mattson and Haack 1987). Populations of many species can suffer severe mortality as a result of these factors, and rare species may be eliminated (Schowalter 1985, P. Shaw et al. 1987). Willig and Camilo (1991) reported the virtual disappearance of two species of walking-sticks, *Lamponius portoricensis* and *Agamemnon iphimedia*, from tropical rain forests in Puerto Rico following Hurricane Hugo. Drought can reduce water levels in aquatic ecosystems, reducing or eliminating habitat for some aquatic insects. In contrast, storms may redistribute insects picked up by high winds. Torres (1988) documented large numbers of insects being transported to Caribbean islands by hurricane winds, including swarms of African desert locusts, *Schistocerca gregaria*.

Mortality depends on disturbance intensity and scale and species adaptation. K. Miller and Wagner (1984) reported that the Pandora moth preferentially pupates on soil with sparse litter cover, under open canopy, where it is more likely to survive frequent understory fires. This habit would not protect pupae during more severe fires. Small scale disturbances affect a smaller proportion of the population than do larger scale disturbances. Large scale disturbances, such as volcanic eruptions or hurricanes, could drastically reduce populations over much of the species range, making such populations vulnerable to extinction. The potential for disturbances to eliminate small populations, or critical local demes of fragmented metapopulations, has become a serious obstacle to restoration of endangered (or other) species (P. Foley 1997).

Disturbances can affect insect populations indirectly by altering the distribution of resources, or by changing species interactions in the post-disturbance environment. Disturbance affects the abundance or physiological condition of hosts and the abundances or activity of other associated organisms (Mattson and Haack 1987, T. Paine and Baker 1993). Selective mortality to disturbance-intolerant plant species reduces the availability of their resources to associated herbivores. Similarly, long disturbance-free intervals can lead to the eventual replacement of ruderal plant species and their associated insects. Changes in canopy cover or plant density alter the vertical and horizontal gradients in light, temperature and moisture which influence habitat suitability for insect species, alter plant conditions, including nitrogen concentrations, and can alter the vapor diffusion patterns that influence chemo-orientation by insects (Cardé 1996, Kolb et al. 1998, Mattson and Haack 1987, J. Stone et al. 1999).

Disturbances can injure or stress surviving hosts or may change plant species density or apparency. The grasshopper, *Melanoplus differentialis*, prefers wilted sunflower foliage to turgid foliage (A. Lewis 1979). Fire or storms can wound surviving plants and increase their susceptibility to herbivorous insects. Lightning-struck (Fig. 6.5) or windthrown trees are particular targets for many bark beetles and provide refuges for these insects at low population levels (Flamm et al. 1993, T. Paine and Baker 1993). Drought stress can cause audible cell wall cavitation that may attract insects which are adapted to exploit water-stressed hosts (Mattson and Haack 1987). Stressed plants may alter their production



**FIG. 6.5** Lightning-strike or other injury or stress impairs tree defense systems. Injured, diseased, or water-stressed trees typically are targets of bark beetle colonization.

of particular amino acids or suppress production of defensive chemicals to meet more immediate metabolic needs, thereby affecting their suitability for particular herbivores (Haglund 1980, Lorio 1993, R. Waring and Pitman 1983). If drought or other disturbances stress large numbers of plants surrounding these refuges, small populations can reach epidemic sizes quickly (Breshears et al. 2005, Mattson and Haack 1987). Plant crowding, as a result of planting or long disturbance-free intervals, causes competitive stress. High densities and/or apparencies of a particular plant species will facilitate host colonization and population growth, frequently triggering outbreaks of herbivorous species (Mattson and Haack 1987).



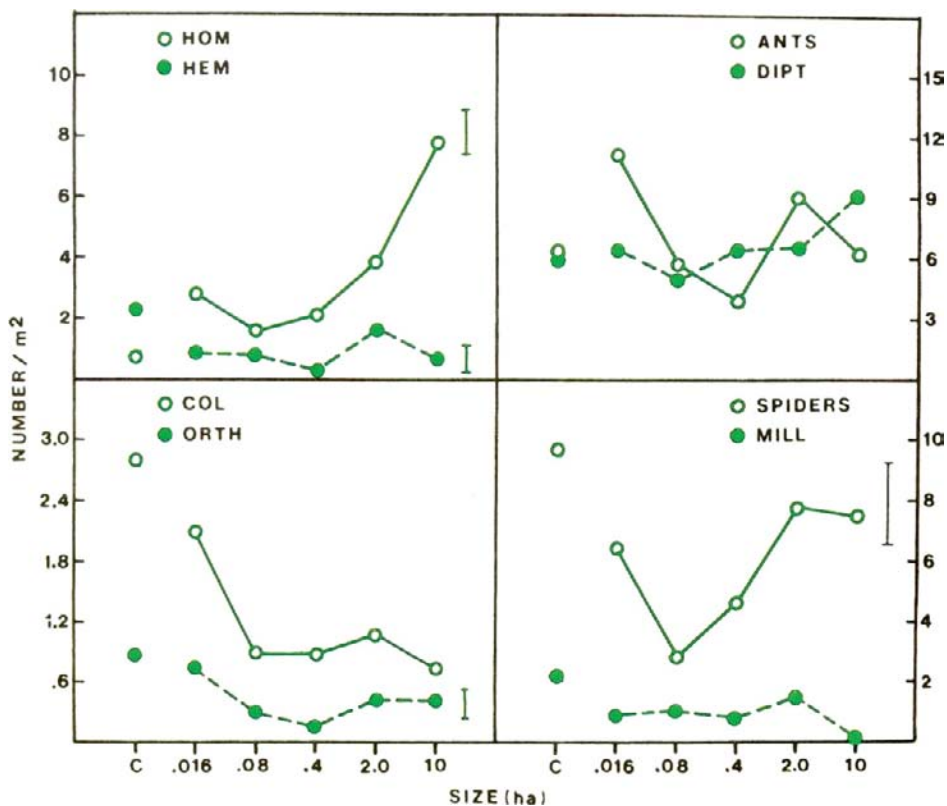
Changes in the abundances of competitors, predators and pathogens also affect post-disturbance insect populations. For example, phytopathogenic fungi establishing in, and spreading from, woody debris in the aftermath of a fire, windthrow, or harvest can stress infected surviving trees and increase their susceptibility to bark beetles and other wood boring insects (T. Paine and Baker 1993). Drought or solar exposure resulting from disturbance can reduce the abundance or virulence of entomopathogenic nematodes, fungi, bacteria or viruses (Mattson and Haack 1987, Priesser and Strong 2004, Roland and Kaupp 1995). Disturbance and/or fragmentation reduce the abundances and activity of some predators and parasites (Kruess and Tschardtke 1994, Roland and Taylor 1997) and may induce or support outbreaks of defoliators (Roland 1993). Alternatively, fragmentation can interrupt the spread of some insect populations by creating inhospitable barriers (Schowalter et al. 1981b).

The responses of a population to direct or indirect effects vary, depending on the scale of disturbance (see Chapter 7). Few natural experiments have addressed the effects of scale. Clearly, a larger scale event should affect environmental conditions and populations within the disturbed area more than would a smaller scale event. Shure and Phillips (1991) compared arthropod abundances in clearcuts of different sizes in the southeastern U.S. (Fig. 6.6). They suggested that the greater differences in arthropod densities in larger clearcuts reflected the steepness of environmental gradients from the clearcut into the surrounding forest. The surrounding forest has a greater effect on environmental conditions within a small canopy opening than within a larger opening.

The capacity for insect populations to respond quickly to abrupt changes in environmental conditions (disturbances) indicates their capacity to respond to more gradual environmental changes. Insect outbreaks have become particularly frequent and severe in landscapes that have been significantly altered by human activity (Hadley and Veblen 1993, Huettl and Mueller-Dombois 1993, Wickman 1992). Anthropogenic suppression of fire, channelization and clearing of riparian areas, and conversion of natural, diverse vegetation to rapidly-growing, commercially-valuable crop species on a regional scale have resulted in more severe disturbances and dense monocultures of susceptible species that support widespread outbreaks of adapted insects (e.g., Schowalter and Lowman 1999).

Insect populations are also likely to respond to changing global temperature, precipitation patterns, atmospheric and water pollution, and atmospheric concentrations of CO<sub>2</sub> and other trace gases (e.g., Alstad et al. 1982, Esper et al. 2007, Franklin et al. 1992, Heliövaara 1986, Heliövaara and Väisänen 1993, L. Hughes and Bazzaz 1997, Lincoln et al. 1993, Marks and Lincoln 1996, D. Williams and Liebhold 2002). Grasshopper and bark beetle populations are favored by warm, dry conditions (Breshears et al. 2005, Capinera 1987, Konishi and Itô 1973, Ma 1958, Mattson and Haack 1987), which are predicted by climate change models to increase in many regions. D. Williams and Liebhold (2002) projected an increased outbreak area and a shift northward for southern pine beetle, *D. frontalis*, but a reduced outbreak area and a shift to higher elevations for the mountain pine beetle, *Dendroctonus ponderosae*, in North America as a result of increasing temperature. Interaction among multiple factors that are changing simultaneously may affect insects in a different manner than would be predicted from responses to individual factors (e.g., Franklin et al. 1992, Marks and Lincoln 1996).

The similarity in the responses of an insect population to natural vs. anthropogenic changes in the environment depends on the degree to which anthropogenic changes create conditions which are similar to those created by natural changes. For example, natural disturbances typically remove less biomass from a site than do harvest or livestock grazing.



**FIG. 6.6** Densities of arthropod groups during the first growing season in uncut forest (C) and clearcut patches ranging in size from 0.016 ha to 10 ha. For groups showing significant differences between patch sizes, vertical bars indicate the least significant difference ( $P < 0.05$ ). HOM=Homoptera, HEM=Hemiptera, COL=Coleoptera, ORTH=Orthoptera, DIPT=Diptera, and MILL=millipedes. From Shure and Phillips (1991), with kind permission from the authors and Springer Science+Business Media: *Oecologia*, 1991, Patch size of forest openings and arthropod populations, 86: 325–334, Shure, D.J. and D.L. Phillips, Figure 3.

This difference probably affects insects that depend on post-disturbance biomass, such as large woody debris, either as a food resource or a refuge from exposure to altered temperature and moisture (Grove 2002, Seastedt and Crossley 1981a). Anthropogenic disturbances leave straighter and more distinct boundaries between disturbed and undisturbed patches (because of ownership or management boundaries), thereby affecting the character of edges and the steepness of environmental gradients into undisturbed patches (J. Chen et al. 1995, Roland and Kaupp 1995). Similarly, the scale, frequency and intensity of prescribed fires may differ from natural fire regimes. In northern Australia, natural ignition would come from lightning during storm events at the onset of monsoon rains, whereas prescribed fires often are set during drier periods to maximize fuel reduction (Braithwaite and Estbergs 1985). Consequently, prescribed fires burn hotter, are more homogeneous in their severity, and cover larger areas than do lower intensity, more patchy fires burning during cooler, moister periods.

Few studies have evaluated the responses of insect populations to changes in multiple factors. Habitat fragmentation, climate change, acid precipitation, multiple atmospheric

pollutants and introduction of exotic species may influence insect populations interactively in many areas (e.g., Lerdau et al. 1997, Valkama et al. 2007). For example, stepwise multiple regression indicated that the persistence of native ant species in coastal scrub habitats in southern California was best predicted by the abundance of invasive Argentine ants, *Linepithema humile*, the size of habitat fragments, and time since fragment isolation (A. Suarez et al. 1998).

## B Density Dependent Factors

Primary density-dependent factors include intra- and interspecific competition, for limited resources, and predation. The relative importance of these factors has been the topic of much debate. Resource limitation is a significant factor for all organisms. Malthus (1789) wrote the first theoretical treatise describing the increasing struggle for limited resources by growing populations. Effects of intraspecific competition on natality, mortality and dispersal have been demonstrated widely (see Chapter 5). As competition for finite resources becomes increasingly intense, fewer individuals obtain sufficient resources to survive, reproduce or disperse. Similarly, the rich literature on predator–prey interactions generally, and biocontrol agents in particular, has shown the important density-dependent effects of predators, parasitoids, and parasites on prey populations (e.g., Carpenter et al. 1985, Marquis and Whelan 1994, Parry et al. 1997, Price 1997, Tinbergen 1960, van den Bosch et al. 1982, Van Driesche and Bellows 1996). Predation rates typically increase as prey abundance increases, up to a point at which predators become satiated. Predators respond both behaviorally and numerically to changes in prey density (see Chapter 8). They can be attracted to an area of high prey abundance, a behavioral response, and increase production of offspring as food supply increases, a numerical response. Parasites are not subject to satiation, and natural epizootics commonly terminate outbreaks (e.g., Brookes et al. 1978, see Chapter 8).

Cooperative interactions among individuals can lead to inverse density-dependence, i.e., positive feedback, up to a point. Mating success (and thus natality) increases as density increases. Some insects show an increase in their ability to exploit resources as density increases. Examples include bark beetles that must aggregate in order to kill trees, a necessary prelude to successful reproduction (Berryman 1997, Coulson 1979), and social insects that increase thermoregulation and recruitment of nestmates to harvest suitable resources as colony size increases (Heinrich 1979, Matthews and Matthews 2010).

Factors affecting population size can operate over a range of time delays. For example, fire affects numbers immediately (no time lag) by killing exposed individuals, whereas predation requires some period of time (time lag) for predators to aggregate in an area of dense prey and to produce offspring. Hence, increased prey density is followed by increased predator density only after a given time lag. Similarly, as prey abundance decreases, predators disperse or cease reproduction, but again, only after a time lag.

## C Regulatory Mechanisms

When population size exceeds the number of individuals that can be supported by existing resources, competition and other factors reduce this size until it reaches levels in balance with resource supply. This equilibrium population size, which can be sustained indefinitely by resource availability, is termed the **carrying capacity** of the environment and is designated as **K**. Carrying capacity is not constant, but depends on factors that

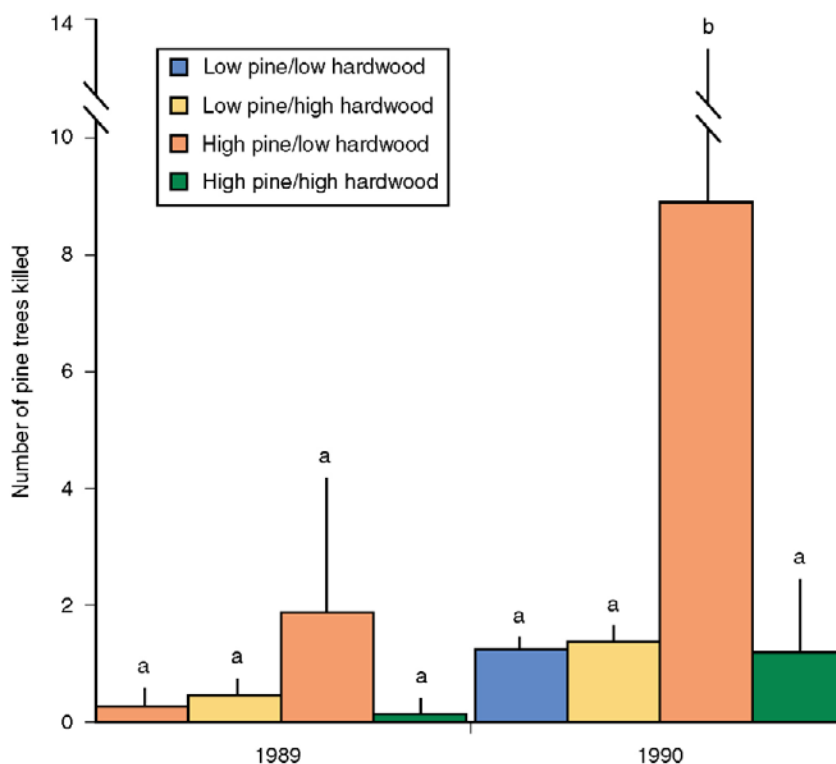
affect both the abundance and suitability of necessary resources, including the intensity of competition with other species that also use those particular resources.

Density-independent factors modify population size, but only density-dependent factors can regulate population size, in the sense of stabilizing abundance near carrying capacity. Regulation requires environmental feedback, such as via density-dependent mechanisms which reduce population growth at high densities but allow population growth at low densities (Isaev and Khlebopros 1979). Nicholson (1933, 1954a, b, 1958) first postulated that density-dependent biotic interactions are the primary factors that determine population size. Andrewartha and Birch (1954) challenged this view, suggesting that density-dependent processes are generally of minor importance in determining abundance. This debate was resolved with the recognition that regulation of population size requires density-dependent processes, but abundance is determined by all factors that affect the population (Begon and Mortimer 1981, Isaev and Khlebopros 1979). However, debate continues over the relative importances of competition and predation, the so-called “**bottom-up**” (or **resource concentration**) and “**top-down**” (or **trophic cascade**) hypotheses, for regulating population sizes (see also Chapter 8).

Bottom-up regulation is accomplished through the dependence of populations on resource supply. Suitable food is most often invoked as the limiting resource, but suitable shelter and oviposition sites also may become limiting as populations grow. Increased quality or availability of resources promotes population growth. As populations grow, resources become increasingly limited, hence objects of intense competition. This reduces natality and increases mortality and dispersal (Chapter 5), which eventually reduce population growth. As population size declines, resources become relatively more available and support population re-growth. Therefore, a population should tend to fluctuate around the size (carrying capacity) that can be sustained by resource supply.

Top-down regulation is accomplished through the response of predators and parasites to increasing prey/host availability. As prey abundance increases, predators and parasites encounter more prey. Predators respond functionally to the increased abundance of a prey species by learning to acquire prey more efficiently, and they respond numerically by increasing population size as food supply increases (see Chapter 8). Increased intensity of predation reduces prey numbers. Reduced prey availability limits food supply for predators and reduces predator abundance and the intensity of predation. Hence a prey population should fluctuate around the size determined by intensity of predation.

A number of experiments have demonstrated the dependence of insect population growth on resource availability, especially the abundance of suitable food resources (e.g., M. V. Brown et al. 1987, Cappuccino 1992, Harrison 1994, Lunderstädt 1981, Ohgushi and Sawada 1985, Polis and Strong 1996, Price 1997, Ritchie 2000, Schowalter and Turchin 1993, Schultz 1988, Scriber and Slansky 1981, Varley and Gradwell 1970). For example, S. Eggert and Wallace (2003) demonstrated experimentally that removal of resources led to reduced abundances of aquatic detritivores. Improved food quality or abundance as a result of environmental changes frequently result in population growth of herbivorous species. Jactel and Brockerhoff (2007) conducted a meta-analysis of 119 studies that compared insect herbivory in monoculture and mixed-species forests. Overall, herbivory was significantly higher in monocultures than in more diverse forests. However, this pattern was more significant for specialist herbivores than for generalists and depended on the particular tree species mix, i.e., relative abundances of host vs. non-host species in diverse forests. Schowalter and Turchin (1993) demonstrated that growth of southern pine beetle populations, measured as number of host trees killed, was significant only under



**FIG. 6.7** Effect of host (pine) and non-host (hardwood) densities on population growth of the southern pine beetle, measured as pine mortality in 1989 (Mississippi) and 1990 (Louisiana). Low pine =  $11\text{--}14\text{ m}^2\text{ ha}^{-1}$  basal area; high pine =  $23\text{--}29\text{ m}^2\text{ ha}^{-1}$  basal area; low hardwood =  $0\text{--}4\text{ m}^2\text{ ha}^{-1}$  basal area; high hardwood =  $9\text{--}14\text{ m}^2\text{ ha}^{-1}$  basal area. Vertical lines indicate standard error of the mean. Bars under the same letter did not differ at an experiment-wise error rate of  $P < 0.05$  for data combined for the two years. Data from Schowalter and Turchin (1993).

conditions of high host density and low non-host density (Fig. 6.7). However, some populations appear not to be food limited (D. Wise 1975). Many exotic herbivores are generalists that are regulated poorly in the absence of co-evolved predators, although this also could reflect poor defensive capacity by non-adapted plants.

Population regulation by predators or parasites has been supported by experiments that have demonstrated population growth following predator or parasite removal (Beard et al. 2003, Carpenter and Kitchell 1987, 1988, Dial and Roughgarden 1995, Marquis and Whelan 1994, Oksanen 1983, Turchin et al. 1999) or population decline following predator or parasite augmentation (Priesser and Strong 2004). Manipulative experiments have shown that increased abundance at one predator trophic level causes reduced abundance at the next lower trophic level and increased abundance at the second trophic level down; a trophic cascade (Carpenter and Kitchell 1987, 1988, Letourneau and Dyer 1998). However, in many cases, predators appear simply to respond to prey abundance without regulating prey populations (Parry et al. 1997), and the effect of predation and parasitism often is delayed (Turchin et al. 1999), and hence it is less obvious than the effects of resource supply.

Regulation by lateral factors does not involve other trophic levels. Interference competition, territoriality, cannibalism and density-dependent dispersal have been considered

to be lateral factors that may have a primary regulatory role (Harrison and Cappuccino 1995). For example, Fox (1975a) reviewed studies indicating that cannibalism is a predictable part of the life history of some species, acting as a population control mechanism that rapidly decreases the number of competitors, regardless of food supply. In the backswimmer, *Notonecta hoffmanni*, cannibalism of young nymphs by older nymphs occurred even when alternative prey were abundant (Fox 1975b). In other species, any exposed or unprotected individuals are attacked (Fox 1975a). However, competition clearly is affected by resource supply.

Harrison and Cappuccino (1995) compiled data from 60 studies in which bottom-up, top-down, or lateral density-dependent regulatory mechanisms were evaluated for populations of invertebrates, herbivorous insects, and vertebrates. They reported that bottom-up regulation was apparent in 89% of the studies, overall, compared to observation of top-down regulation in 39% and lateral regulation in 79% of the studies. Top-down regulation was observed more frequently than bottom-up regulation only for the category that included fish, amphibians and reptiles. Bottom-up regulation may predominate in (primarily terrestrial) systems where resource suitability is more limiting than is resource density, i.e., resources are defended in some way (especially through incorporation of carbohydrates into indigestible lignin and cellulose). Top-down regulation may predominate in (primarily aquatic) systems where resources are relatively undefended, or consumers are adapted to defenses, and production can compensate for consumption (D. Strong 1992, see also Chapter 11).

Regulating factors can have indirect, as well as direct, effects on population dynamics (see Chapter 8). For example, ants affected the gall-forming psyllid, *Baccharopelma dracunculifoliae*, abundance directly by interfering with female oviposition behavior, and indirectly by tending aphids, *Uroleucon erigeronensis*, which competed for host resources (Fagundes et al. 2005).

All populations probably are regulated simultaneously by bottom-up, top-down and lateral factors (Denno et al. 2002, 2003, Fagundes et al. 2005, Stiling and Moon 2005). Some resources are more limiting than others for all species, but changing environmental conditions can affect the abundance or suitability of particular resources and can affect higher trophic levels, either directly or indirectly (M. Hunter and Price 1992, Polis and Strong 1996, Power 1992). Environmental changes that stress vegetation can increase the suitability of a food plant without changing its abundance. Such changes also can increase the density or geographic distribution of resources. Under such circumstances, the disruption of bottom-up regulation results in population growth and, thereby, increases prey availability, and perhaps suitability (Stamp 1992, Traugott and Stamp 1996), for predators and parasites, hence resulting in increased abundance at that trophic level. Species often respond differentially to the same change in resources or predators. Ritchie (2000) reported that experimental fertilization (with nitrogen) of grassland plots resulted in increased host plant quality for, and density of, polyphagous grasshoppers, but did not affect grass quality, and resulted in reduced density of grass-feeding grasshoppers. Denno et al. (2002, 2003) manipulated both bottom-up (host plant biomass and nutrition) and top-down (predation by spiders) factors and concluded that bottom-up factors predominated in regulating populations of six sap-feeding insect species. The impact of predation was significant only for two species of planthoppers, *Prokelisia* spp., and was mediated by vegetation biomass and complexity. Stiling and Moon (2005) simultaneously manipulated host plant, *Borrchia frutescens*, nutritional (nitrogen) quality and density and parasitoid abundance and measured the resulting effects on abundances of a meristem-galling fly,

*Asphondylia borrichiae*, and a planthopper, *Pissonotus quadripustulatus*. Abundances of both herbivores were positively related to plant nitrogen, but not plant density at the scale of the study, and to parasitoid removal. Density-dependent competition and dispersal, as well as increased predation, eventually cause the population to decline to levels at which these regulatory factors become less operative.

Whereas density dependence acts in a regulatory (stabilizing) manner through negative feedback, i.e., acting to slow or stop continued growth, inverse density dependence has been thought to act in a destabilizing manner. Allee (1931) first proposed that positive feedback creates unstable thresholds, i.e., an **extinction threshold** below which a population inevitably declines to extinction, and the **release threshold** above which the population grows uncontrollably until resource depletion or epizootics decimate the population (Begon and Mortimer 1981, Berryman 1996, 1997, Isaev and Khlebopros 1979). Between these thresholds, density dependent factors should maintain stable populations near  $K$ , a property known as the **Allee effect**. However, positive feedback may ensure population persistence at low densities and is counteracted, in most species, by the effects of crowding, resource depletion, and predation at higher densities.

Clearly, conditions that bring populations near their release or extinction thresholds are of particular interest to ecologists, as well as to resource managers. Host plant density and stress have been identified as factors that promote population irruptions (Koricheva et al. 1998, 2000, Mattson and Haack 1987, Priesser and Strong 2004, Schowalter and Turchin 1993). G. Bell and Gonzalez (2009) tested the responses of yeast populations to normally lethal concentrations of salt and demonstrated that the ability of a population to recover from collapse reflected a threshold in initial population size, i.e., sufficient numbers to avoid stochastic extinction and to contain resistant genomes. Among insects, low-density populations are particularly vulnerable to the failure of potential mates to find each other (Gascoigne et al. 2009, Kramer et al. 2009, Yamanaka and Liebhold 2009).

Bazykin et al. (1997), Berryman et al. (1987) and Turchin (1990) demonstrated the importance of time lags to the effectiveness of regulatory factors. They demonstrated that time lags weaken negative feedback and reduce the rigidity of population regulation. Hence, populations that are controlled primarily by factors that operate through delayed negative feedback should exhibit greater amplitude of population fluctuation, whereas populations that are controlled by factors with more immediate negative feedback should be more stable. J. Myers (1988) and Mason (1996) concluded that the delayed effects of density-dependent factors can generate outbreak cycles with an interval of about 10 yrs. For irruptive and cyclic populations, decline to near or below local extinction thresholds may affect the time necessary for population recovery between outbreaks.

### III. MODELS OF POPULATION CHANGE

Models are representations of complex phenomena and are used to understand and predict changes in those phenomena. Population dynamics of various organisms, especially insects, are of particular concern because changes in population size affect human health, ecosystem services, and the quality of terrestrial and aquatic ecosystems. Hence, development of models to improve our ability to understand and predict changes in insect population abundances has a rich history.

Models take many forms. The simplest are conceptual models that clarify relationships between cause and effect. For example, box-and-arrow diagrams can be used to show which system components interact with each other (e.g., Fig. 1.3). More complex statistical

models represent those relationships in quantitative terms, e.g., regression models which depict the relationship between population size and environmental factors (e.g., Fig. 5.5 and 5.6). Advances in computational technology have led to development of biophysical models that can integrate large datasets to predict the responses of insect populations to a wide variety of interacting environmental variables. Computerized decision support systems integrate a user interface with component sub-models that can be linked in various ways, based on user-provided key words, to provide output to answer specific questions (e.g., C. Shaw and Eav 1993).

### A. Exponential and Geometric Models

The simplest model of population growth describes change in numbers as the product of initial population size and the per capita rate of increase (Fig. 6.8) (Berryman 1997, Price 1997). This model integrates per capita natality, mortality, immigration and emigration per unit time as the instantaneous or **intrinsic rate of increase**, which is designated  $r$ .

$$r = (N + I) - (M + E) \quad (6.1)$$

where  $N$  = natality,  $I$  = immigration,  $M$  = mortality, and  $E$  = emigration, all instantaneous rates.

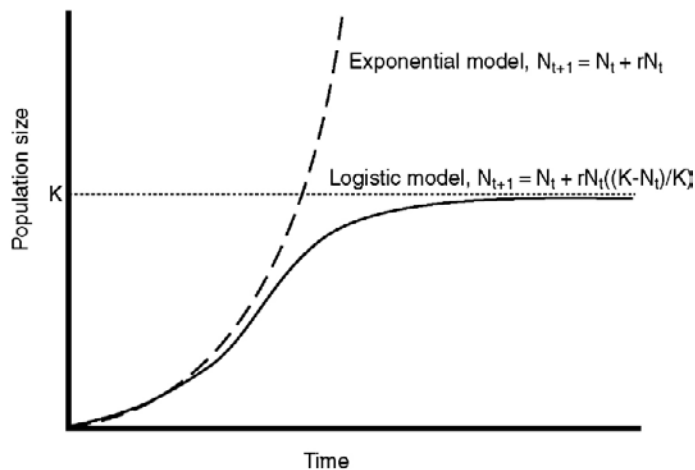
Where cohort life table data, rather than time-specific natality, mortality and dispersal, have been collected,  $r$  can be estimated as:

$$r = \frac{\log_e R_0}{T} \quad (6.2)$$

where  $R_0$  is replacement rate, and  $T$  is generation time.

The rate of change for populations with overlapping generations is a function of the intrinsic (per capita) rate of increase and the current population size. The resulting model for exponential population growth is:

$$N_{t+1} = N_t + rN_t \quad (6.3)$$



**FIG. 6.8** Exponential and logistic models of population growth. The exponential model describes an indefinitely increasing population, whereas the logistic model describes a population reaching an asymptote at the carrying capacity of the environment ( $K$ ).



where  $N_t$  is the population size at time  $t$ , and  $N_0$  is the initial population size. This equation also can be written as:

$$N_t = N_0 e^{rt} \quad (6.4)$$

For insect species with non-overlapping cohorts (generations), the replacement rate,  $R_0$ , represents the per capita rate of increase from one generation to the next. This parameter can be used in place of  $r$  for such insects. The resulting expression for geometric population growth is:

$$N_t = R_0^t N_0 \quad (6.5)$$

where  $N_t$  is the population size after  $t$  generations.

Equations 6.3–6.5 describe density-independent population growth (Fig. 6.8). However, as discussed above, density-dependent competition, predation and other factors interact to limit population growth.

## B. Logistic Model

A mathematical model to account for density-dependent regulation of population growth was developed by Verhulst in 1838 and again, independently, by Pearl and Reed (1920). This logistic model (Fig. 6.8), often called the Pearl–Verhulst equation (Berryman 1981, Price 1997), is expressed as:

$$N_{t+1} = N_t + rN_t \frac{(K - N_t)}{K} \quad (6.6)$$

where  $K$  is the carrying capacity of the environment.

This model describes a sigmoid (S-shaped) curve (Fig. 6.8) that reaches equilibrium at  $K$ . If  $N < K$ , then the population will increase up to  $N = K$ . If the ecosystem is disturbed in a way that  $N > K$ , then the population will decline to  $N = K$ .

## C. Complex Models

General models such as the Pearl–Verhulst equation usually do not predict the dynamics of real systems accurately. For example, the use of the logistic growth model is limited by several assumptions. First, individuals are assumed to be equal in their reproductive potential. Clearly, immature insects and males do not produce offspring, and females vary in their productivity, depending on nutrition, access to oviposition sites, etc. Second, population adjustment to changing density is assumed to be instantaneous, and effects of density-dependent factors are assumed to be a linear function of density. These assumptions ignore time lags, which may control dynamics of some populations and obscure the importance of density dependence (Turchin 1990). Finally,  $r$  and  $K$  are assumed to be constant. In fact, changes in the factors (including  $K$ ) that affect natality, mortality and dispersal will affect  $r$ . Changing environmental conditions, including elimination of resources by disturbances, affect  $K$ . Therefore, population size fluctuates with an amplitude that reflects variation in both  $K$  and the life history strategy of any particular insect species under consideration. Species with the  $r$ -strategy (high reproductive rates and low competitive ability) tend to undergo boom-and-bust cycles because of their tendency to overshoot  $K$ , deplete resources, and decline rapidly, often approaching their extinction threshold, whereas species with the  $K$ -strategy (low reproductive rates and high competitive ability) tend to approach  $K$ .

more slowly and maintain relatively stable population sizes near  $K$  (Boyce 1984). Modeling real populations of interest, then, requires development of complex models with additional parameters that correct these shortcomings, some of which are described below.

Non-linear density-dependent processes and delayed feedback can be addressed by allowing  $r$  to vary as:

$$r = r_{\max} - sN_{t-T} \quad (6.7)$$

where  $r_{\max}$  is the maximum per capita rate of increase,  $s$  represents the strength of interaction between individuals in the population, and  $T$  is the time delay in the feedback response (Berryman 1981). The sign and magnitude of  $s$  also can vary, depending on the relative dominance of competitive and cooperative interactions:

$$s = s_p - s_m N_t \quad (6.8)$$

where  $s_p$  is the maximum benefit from cooperative interactions, and  $s_m$  is the competitive effect, assuming that  $s$  is a linear function of population density at time  $t$  (Berryman 1981). The extinction threshold,  $E$ , can be incorporated by adding a term which forces population change to be negative below this threshold:

$$N_{t+1} = N_t + rN_t \frac{(K-N_t)}{K} \frac{(N_t - E)}{E} \quad (6.9)$$

Similarly, the effect of factors influencing natality, mortality and dispersal can be incorporated into the model to improve representation of  $r$ .

The effect of other species interacting with a population was addressed first by Lotka (1925) and Volterra (1926). The Lotka–Volterra equation for the effect of a species competing for the same resources includes a term that reflects the degree to which the competing species reduces carrying capacity:

$$N_{1(t+1)} = N_{1t} + r_1 N_{1t} \frac{(K_1 - N_{1t} - \alpha N_{2t})}{K_1} \quad (6.10)$$

where  $N_1$  and  $N_2$  are populations of two competing species, and  $\alpha$  is a competition coefficient that measures the per capita inhibitive effect of species 2 on species 1.

Similarly, the effects of a predator on a prey population can be incorporated into the logistic model (Lotka 1925, Volterra 1926) as:

$$N_{1(t+1)} = N_{1t} + r_1 N_{1t} - \rho N_{1t} N_{2t} \quad (6.11)$$

where  $N_1$  is prey population density,  $N_2$  is predator population density, and  $\rho$  is a predation constant. This equation assumes random movement of prey and predator, successful prey capture and consumption for each encounter with a predator, and no self-limiting density effects for either population (Pianka 1974, Price 1997).

Pianka (1974) suggested that competition among prey could be incorporated by modifying the Lotka–Volterra competition equation as:

$$N_{1(t+1)} = N_{1t} + r_1 N_{1t} - \frac{r_1 N_{1t}^2}{K_1} - \frac{r_1 N_{1t} \alpha_{12} N_{2t}}{K_1} \quad (6.12)$$

where  $\alpha_{12}$  is the per capita effect of the predator on the prey population. The prey population is density-limited as carrying capacity is approached.

May (1981) and Dean (1983) modified the logistic model to include the effects of mutualists on population growth. Species interaction models are discussed more fully in Chapter 8.

Gutierrez (1996) and Royama (1992) discussed additional population modeling approaches, including the incorporation of population age and mass structure and refuges from predation. Clearly, the increasing complexity of these models, as more parameters are included, requires computerization for prediction of population trends.

#### D. Computerized Models

Computerized simulation models have been developed to project the abundances of insect populations that affect crop and forest resources (e.g., Gutierrez 1996, Royama 1992, Rykiel et al. 1984). The models which have been developed for several important forest and range insects are arguably the most sophisticated population dynamics models available to date, because they incorporate long time frames, effects of a variety of interacting factors (including climate, soils, host plant variables, competition and predation) on insect populations, and effects of population change on ecosystem structure and processes. Often, the population dynamics model is integrated with plant growth models, impact models that address effects of population change on ecological, social and economic variables, and management models that address effects of manipulated resource availability and insect mortality on the insect population (Colbert and Campbell 1978, Leuschner 1980). As more information becomes available on population responses to various factors, or effects on ecosystem processes, the model can be updated, increasing the realism of its representation of population dynamics and the accuracy of predictions.

Effects of various factors can be modeled as deterministic (fixed value), stochastic (value based on probability functions) or chaotic (random values) variables (e.g., Croft and Gutierrez 1991, Hassell et al. 1991, Logan and Allen 1992). If natality, mortality and survival are highly correlated with temperature, these rates would be modeled as a deterministic function of temperature. On the other hand, the effects of plant condition on these rates might be described best by probability functions and modeled stochastically (Fargo et al. 1982, Matis et al. 1994). A. King et al. (2004) reported that chaotic dynamics could produce near-cyclic patterns and that the particular patterns observed depend on the scale of study.

Advances in **chaos theory** are contributing to the development of population models which more accurately represent the apparently erratic behavior of many insect populations (Cavaliere and Koçak 1994, 1995a, b, Costantino et al. 1997, Cushing et al. 2003, Hassell et al. 1991, A. King et al. 2004, Logan and Allen 1992). Chaos theory addresses the unpredictable ways in which the initial conditions of a system can affect its subsequent behavior. In other words, population trend at any instant is the result of the unique combination of population and environmental conditions at that instant. For example, changes in gene frequencies and the behavior of individuals over time affect the way in which populations respond to environmental conditions. Time lags, nested cycles, and non-linear interactions with other populations are characteristics of ecological structure that inherently destabilize mathematical models and introduce chaos (Cushing et al. 2003, Logan and Allen 1992).

Chaos has been difficult to demonstrate in populations, and its importance to population dynamics is a topic of debate. Dennis et al. (2001) demonstrated that a deterministic model of flour beetle, *Tribolium castaneum*, population dynamics accounted for > 92% of

the variability in life stage abundances but was strongly influenced by chaotic behavior at certain values for the coefficient of adult cannibalism of pupae (Fig. 6.9).

Several recent studies have suggested that insect population dynamics can undergo recurring transition between stable and chaotic phases when certain variables have values that place the system near a transition point between order and chaos (Cavalieri and Koçak 1995a, b, Costantino et al. 1997) or when influenced by a generalist predator and specialist pathogen (Dwyer et al. 2004). Cavalieri and Koçak (1994, 1995b) found that small changes in weather-related parameters (increased mortality of pathogen-infected individuals or decreased natality of uninfected individuals) in a European corn borer, *Ostrinia nubilalis*, population dynamics model caused a regular population cycle to become erratic. When this chaotic state was reached, the population reached higher abundances than it did during stable cycles, suggesting that small changes in population parameters resulting from biological control agents could be counterproductive. Although chaotic behavior fundamentally limits long-term prediction of insect population dynamics, improved modeling of transitions between deterministic or stochastic phases and chaotic phases may facilitate prediction of short term dynamics (Cavalieri and Koçak 1994, Logan and Allen 1992).

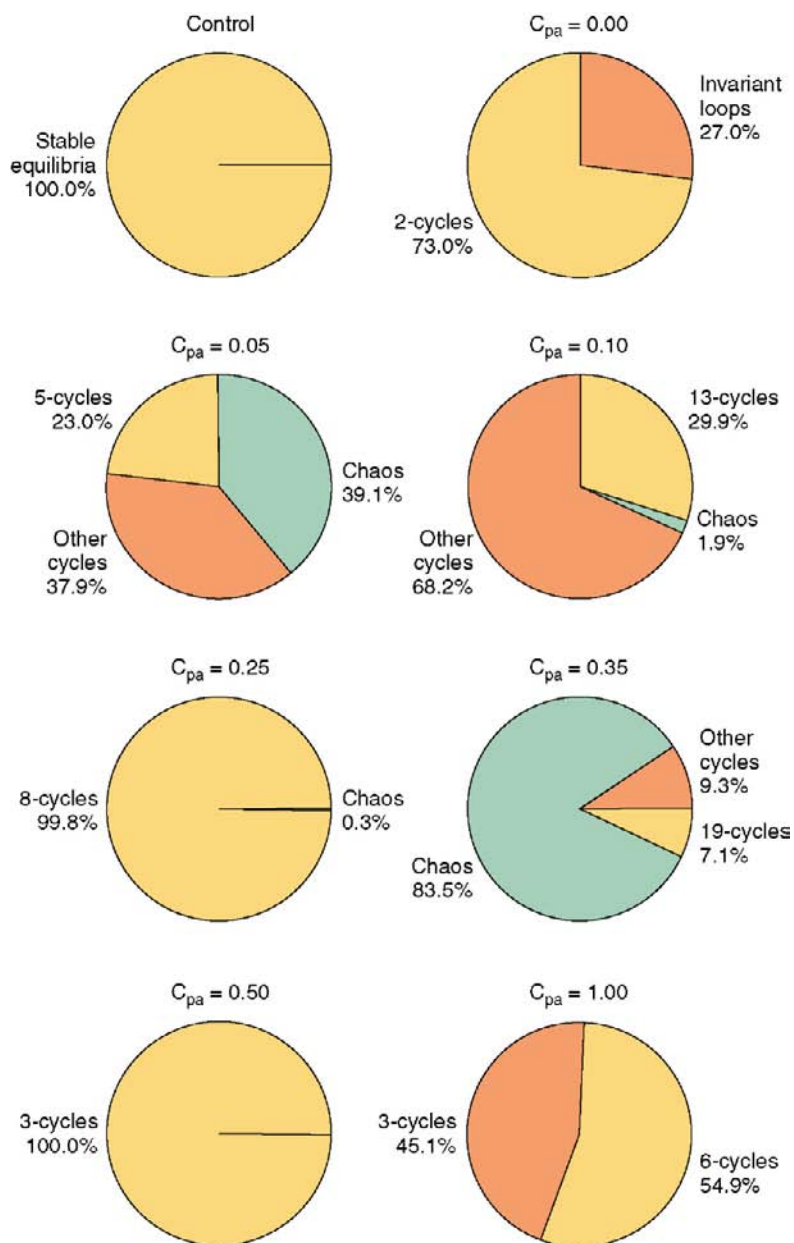
## E. Model Evaluation

The utility of models is often limited by a number of problems. The effects of multiple interacting factors typically must be modeled as the direct effects of individual factors, in the absence of multi-factorial experiments to assess interactive effects. Effects of host condition are often particularly difficult to quantify for modeling purposes, because the factors affecting host biochemistry remain poorly understood for most species. Moreover, models must be initialized with adequate data on current population parameters and environmental conditions. Finally, most models are constructed from data that represent relatively short time periods.

Models most accurately represent the observed dynamics of the populations from which they were developed (e.g., Varley et al. 1973), and confidence in their utility for the prediction of future population trends under a broad range of environmental conditions depends on proper validation of the model. Validation requires comparison of predicted and observed population dynamics using independent data, i.e., data that were not used to develop the model. Such comparisons, when carried out using data that represent a range of environmental conditions, can indicate the generality of the model, and can contribute to the refinement of parameters subject to environmental influence, until the model predicts changes with a reasonable degree of accuracy (Hain 1980).

Departure of predicted results from observed results can indicate several possible weaknesses in the model. First, important factors may be under-represented in the model. For example, unmeasured changes in plant biochemistry during drought periods could significantly affect insect population dynamics. Second, the model structure may be flawed. Major factors affecting populations may not be integrated appropriately in the model. Finally, the quality of data available to initialize the model may be inadequate. Initial values for  $r$ ,  $N_0$  or other variables must be provided or derived from historic data within the model. Clearly, inadequate data or departure of particular circumstances from tabular data will reduce the utility of model output.

Few studies have examined the consequences of using different types of data for model initialization. The importance of data quality for model initialization can be illustrated



**FIG. 6.9** Frequency of predicted deterministic attractors for modeled survival probabilities of pupae in the presence of cannibalistic adults ( $C_{pa}$ ) of *Tribolium castaneum* for 2000 bootstrap parameter estimates. For example, for  $C_{pa} = 0.35$ , 83.5% of estimates produced chaotic attractors, 7.1% produced stable 19-cycles, and 9.3% produced stable cycles of higher periods. From Dennis et al. (2001) with permission of the Ecological Society of America.

by evaluating the effect of several input options on predicted population dynamics of the southern pine beetle. The TAMBEETLE population dynamics model is a mechanistic model that integrates submodels for colonization, oviposition and larval development with variable stand density and microclimatic functions to predict population growth and tree mortality (Fargo et al. 1982, Turnbow et al. 1982). Nine variables describing tree (diameter, infested height and stage of beetle colonization for colonized trees), insect (density of each life stage at multiple heights on colonized trees), and environmental (landform, tree size class distribution and spatial distribution, and daily temperature and precipitation) variables are required for model initialization. Several input options were developed to satisfy these requirements. Options range in complexity from correlative information based on aerial survey or inventory records to detailed information about distribution of beetle life stages and tree characteristics that requires intensive sampling. In the absence of direct data, default values are derived from tabulated data that are based on intensive population monitoring studies.

Schowalter et al. (1982) compared tree mortality predicted by TAMBEETLE using four input options: a) all data needed for initialization (including life stage and intensity of beetles in trees) were provided; b) only environmental data and diameter and height of each colonized tree were provided; c) only environmental data and infested surface area of each colonized tree were provided; and d) only environmental data and number of colonized trees were provided. Predicted tree mortality when all data were provided was twice the predicted mortality when only environmental and tree data were provided, and the former prediction most closely resembled the observed beetle population trends and tree mortality.

Insect population dynamics models typically are developed to address “pest” effects on commodity values. Few population dynamics models explicitly incorporate the effects of population change on ecosystem processes or services. However, a growing number of studies are providing data on effects of insect herbivore or detritivore abundance on primary productivity, hydrology, nutrient cycling, and/or diversity and abundances of other organisms (S. Chapman et al. 2003, Christenson et al. 2002, Classen et al. 2005, Fonte and Schowalter 2005, Frost and Hunter 2004, 2007, 2008a, b, M. Hunter et al. 2003, Klock and Wickman 1978, Leuschner 1980, Schowalter and Sabin 1991, Schowalter et al. 1991, Seastedt 1984, 1985, Seastedt and Crossley 1984, Seastedt et al. 1983, 1988, Whitham et al. 2006, see also Chapters 12–14). Colbert and Campbell (1978) documented the structure of the integrated Douglas-fir tussock moth, *Orgyia pseudotsugata*, model and the effects of simulated changes in moth density (population dynamics submodel) on density, growth rate, and timber production by tree species (stand prognosis model). Leuschner (1980) described development of equations for evaluating direct effects of southern pine beetle population dynamics on timber, grazing and recreational values, hydrology, understory vegetation, wildlife, and likelihood of fire. Effects of the southern pine beetle on these economic values and ecosystem attributes were modeled as functions of the extent of pine tree mortality that resulted from changes in beetle abundance. However, for both the Douglas-fir tussock moth and southern pine beetle models, the effects of population dynamics on ecosystem process that underlie long-term sustainability of multiple ecosystem services are based on limited data.

Modeling of insect population dynamics requires data from the continuous monitoring of population size over long time periods, especially for cyclic and irruptive species, in order to evaluate the effect of changing environmental conditions on population size. Relatively few insect populations, including pest species, have been monitored for longer

than a few decades, and most have been monitored only during outbreaks (e.g., Curry 1994, Turchin 1990). Historic records of outbreak frequency during the past 100–1000 yrs exist for a few species, (e.g., Fitzgerald 1995, Greenbank 1963, Konishi and Itô 1973, Ma 1958, Stige et al. 2007, Turchin 1990, T. White 1969), and, in some cases, outbreak occurrence over long time periods can be inferred from dendrochronological data in old forests (e.g., Esper et al. 2007, Royama 1992, Speer et al. 2001, Swetnam and Lynch 1989, Veblen et al. 1994). However, such data do not provide sufficient detail on concurrent trends in population size and environmental conditions for most modeling purposes. Data that relate changes in population densities to environmental factors cover only a few decades for most species (e.g., Berryman 1981, Mason 1996, Price 1997, Rácz and Bernath 1993, Varley et al. 1973, Waloff and Thompson 1980). For populations that irrupt infrequently, validation often must be delayed until future outbreaks occur.

Despite their limitations, population dynamics models are a valuable tool for synthesizing a vast and complex body of data, for identifying critical gaps in our understanding of factors which affect populations, and for predicting or simulating responses to environmental changes. Therefore, they represent our state-of-the-art understanding of population dynamics, they can be used to focus future research on key questions, and they can contribute to improvements in the efficiency of management or manipulation of important processes. Population dynamics models are the most rigorous tools available for projecting survival or recovery of endangered species and outbreaks of potential pests and their effects on ecosystem services.

#### IV. SUMMARY

Populations of insects can fluctuate dramatically through time, with varying effects on community and ecosystem patterns and processes, as well as on the degree of crowding among members of the population. The amplitude and frequency of fluctuations distinguish irruptive populations, cyclic populations, and stable populations. Cyclic populations have stimulated the greatest interest among ecologists. The various hypotheses that have been developed to explain cyclic patterns of population fluctuation all include density-dependent regulation with a time lag that generates regular oscillations.

Disturbances are particularly important to population dynamics, triggering outbreaks of some species and locally exterminating others. Disturbances can affect insect populations directly by killing intolerant individuals, or indirectly by affecting the abundance and suitability of resources or the abundance and activity of predators and parasites. The extent to which anthropogenic changes in environmental conditions affect insect populations depends on the degree of similarity between conditions which are produced by natural vs. anthropogenic changes.

Population growth can be regulated (stabilized) to a large extent by density-dependent factors, whose probability of effect on individuals increases as density increases and declines as density decreases. Primary density-dependent factors are intra- and inter-specific competition and predation. Increasing competition for food (and other) resources as density increases leads to reduced natality and increased mortality and dispersal, eventually reducing density. Similarly, predation increases as prey density increases. Although the relative importance of these two factors has been debated extensively, both clearly are critical to population regulation. Regulation by bottom-up factors (resource limitation) may be relatively more important in systems where resources are defended or vary significantly in quality, whereas regulation by top-down factors (predation) may be more

important where resources are relatively abundant and show little variation in quality. Inverse density dependence results from cooperation among individuals and represents a potentially destabilizing property of populations. However, this positive feedback may prevent population decline below its extinction threshold. Populations declining below their extinction threshold may be doomed to local extinction, whereas populations increasing above a critical number of individuals (release threshold) continue to increase during an outbreak period. These thresholds represent the minimum and maximum population sizes for species targeted for special management.

Development of population dynamics models has been useful for forecasting changes in insect abundance and effects on crop, range, and forest resources. General models include the logistic (Verhulst–Pearl) equation that incorporates initial population size, per capita natality, mortality, and dispersal (instantaneous rate of population change) and carrying capacity. The logistic equation describes a sigmoid curve that reaches an asymptote at carrying capacity. This general model can be modified for particular species by adding parameters to account for non-linear density-dependent factors, time lags, cooperation, extinction, competition, predation, etc. Models are necessarily simplifications of real systems, and they may represent the effects of multiple interacting factors and chaotic processes poorly. Few models have been validated adequately, and fewer have been evaluated with respect to the effects of quality of data input on the accuracy of their predictions. Few population models have been developed to predict the effects of insect population dynamics on ecosystem services other than commodity production. Nevertheless, models represent powerful tools for synthesizing information, identifying priorities for future research, and simulating population responses to future environmental conditions.



This page intentionally left blank

# Biogeography

- I. Geographic Distribution**
  - A. Global Patterns
  - B. Regional Patterns
  - C. Island Biogeography
  - D. Landscape and Stream Continuum Patterns
- II. Spatial Dynamics of Populations**
  - A. Expanding Populations
  - B. Metapopulation Dynamics
- III. Habitat Connectivity**
- IV. Anthropogenic Effects on Spatial Dynamics**
  - A. Fragmentation
  - B. Disturbances to Aquatic Ecosystems
  - C. Anthropogenic Transport Across Barriers
- V. Models of Spatial Dynamics**
- VI. Summary**

## Gypsy moth spread in North America

The gypsy moth, *Lymantria dispar*, has been among the most destructive invasive species in North America and has a well-documented record of spread since its accidental release in 1869 (C. Riley and Howard 1890, C. Riley and Vasey 1870). Adult females of North American populations are winged but do not fly (Liebhold et al. 1992). Dispersal occurs primarily as new larvae move upward, drop from foliage on silk threads and subsequently are carried on the airstream, often for long distances. Last instar larvae move to sheltered sites, including bark crevices, leaf litter, dead trees, rocks, fence posts, firewood, machinery and vehicles, for pupation and can be carried long distances by human movement of infested materials (Tobin et al. 2007).

The gypsy moth was brought initially to Medford, Massachusetts from France by Léopold Trouvelot as part of his efforts to establish a silk industry in the U.S.A. during the 1860s (Andrews 1868, Trouvelot 1867). Several eggs or caterpillars apparently spilled or escaped from a jar on a window sill (C. Riley and Howard 1890). Trouvelot was unable to recover these and, recognizing the potential threat to North American forests, reported the introduction publicly (C. Riley and Howard 1890, Riley and Vasey 1870), but little attention was given to the announcement at the time.

Local residents of Medford began noticing the caterpillars after about 10 yrs. The man who bought Trouvelot's house in 1879 noted swarms of caterpillars in a shed in the rear of the

(cont.)

property (Forbush and Fernald 1896). Efforts by residents to control the moth on their own properties during the 1880s were unsuccessful. In 1889 the moth reached destructive levels in an area of about 1.4 km<sup>2</sup> in Medford (Forbush and Fernald 1896, C. Riley and Howard 1890), leading to focused efforts by the state to contain and eradicate the population. Eradication efforts, which included burning forests and using arsenical compounds with the earliest pump spray equipment, continued until 1900, at which time three counties (4000 km<sup>2</sup>) were infested (Forbush and Fernald 1896, Liebhold et al. 1992).

The moth subsequently spread at about 10 km yr<sup>-1</sup> from 1900 to 1915, by which time much of New England was infested (about 84,000 km<sup>2</sup>). This was followed by a long period (1916–1965) of slower spread, at about 3 km yr<sup>-1</sup>, by the end of which about 230,000 km<sup>2</sup>, including eastern New York, were infested (Tobin et al. 2007). However, the rate of spread then accelerated to 20 km yr<sup>-1</sup> from 1965 to 1989 (580,000 km<sup>2</sup>), perhaps because the forests of Pennsylvania, Maryland and Virginia had become older and more continuous than they were earlier, because forests in the region had higher proportions of host species than did the forests of New England, and/or because long-distance anthropogenic transportation increased during this period (Liebhold et al. 1992). The moth appeared across the Great Lakes in central Michigan about 1981, spread radially at about 10 km yr<sup>-1</sup> for the next 15 years, and was established in both the Upper and Lower Peninsulas of Michigan and eastern Wisconsin (total infested area about 800,000 km<sup>2</sup>) by 2005 (Tobin et al. 2007).

Federal quarantine of infested counties limited the southward spread after 1990 to only 7 km yr<sup>-1</sup>. However, additional population “jumps” to western states (e.g., California, Oregon, British Columbia) as a result of anthropogenic transport have been treated aggressively and thus far have failed to become established (Liebhold et al. 1992).

## INTRODUCTION

THE GEOGRAPHIC RANGES ACROSS WHICH SPECIES OCCUR GENERALLY reflect the tolerances of individual organisms to geographic gradients in physical conditions (see Chapter 2). However, most species do not occupy the entire area of potentially suitable environmental conditions. Discontinuity in geographic range reflects a number of factors, particularly geographic barriers and disturbance dynamics. By contrast, suitable habitats can be colonized over large distances from population sources, as a result of dispersal processes, which often are aided by anthropogenic movement. Factors determining the geographic distribution of organisms have been a particular subject of investigation for the past several centuries (e.g., Andrewartha and Birch 1954, Price 1997), spurred in large part by European and American exploration, and floral and faunal collections, in continental interiors during the 1800s.

The spatial distribution of populations changes with population size. Growing populations expand over a larger area as individuals in the high density core disperse to the fringe of the population or colonize new patches. Declining populations shrink into refuges that maintain isolated demes of a metapopulation. The spatial distribution of populations is influenced to a considerable extent by anthropogenic activities that determine landscape structure and introduce (intentionally or unintentionally) commercial and “pest” species to new regions. Changes in the presence or abundance of insects may be useful biological indicators of ecosystem conditions across landscapes or regions, depending on the degree of habitat specialization of particular species (Rykken et al. 1997). Changes in the presence and abundance of particular species affects various ecosystem properties, encouraging efforts to predict changes in distributions of insect populations.

## I. GEOGRAPHIC DISTRIBUTION

The geographic distribution of species populations can be described over a range of scales. At the largest scale, some species have population distributions that span large areas of the globe, including multiple continents. At smaller scales, individual species may occur in a suitable portion of a biome or in suitable patches scattered across a biome or landscape. At the same time, species often are absent from apparently suitable habitats. The geographic distribution of individual species can change as a result of changing conditions and/or dispersal.

### A. Global Patterns

Global patterns of distribution reflect latitudinal gradients in temperature and moisture, as well as natural barriers to dispersal. A. Wallace (1876) identified six relatively distinct faunal assemblages that largely coincide with major continental boundaries, but also reflect the history of continental movement, as discussed below. Wallace's **biogeographic realms** (Fig. 7.1) remain a useful template for describing the distribution of species on a global scale. Many taxa occupy large areas within a particular biogeographic realm, e.g., the unique Australian flora and fauna. Others, because of the narrow gap between the Palearctic and Nearctic realms, were able to cross this barrier and exhibit a Holarctic distribution pattern. Of course, many species occupy much smaller geographic ranges, limited by topographic barriers or other factors.

Some distribution patterns, especially of fossil species, are noticeably disjunct. Hooker (1847, 1853, 1860) was among the first to note the similarity of floras found among the lands bordering the southern oceans, including Antarctica, Australia, Tasmania, New Zealand, Tierra del Fuego, the Falklands and other islands. Many genera, and even some species, of plants were shared among these widely separated lands, suggesting a common origin.

Later in the 1800s, evidence of stratigraphic congruence of various plant and animal groups among the southern continents supported a hypothetical separation of northern and southern supercontinents. Wegener (1924) was the first to propose a geologic history of drift for all the continents, concentrated during Cenozoic time. Wegener's **continental drift hypothesis** was criticized because this history appeared to be incompatible with non-marine paleontology. However, a growing body of geologic and biological evidence,

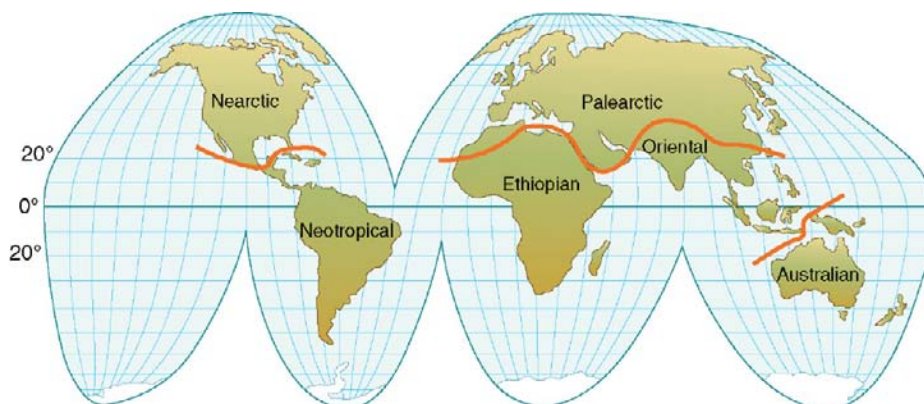


FIG. 7.1 Biogeographic realms identified by A. Wallace (1876).

including stratigraphic congruence, rift valleys, uplift and subsidence zones, and distributions of both extinct and extant flora and fauna, was eventually unified into the **theory of plate tectonics**.

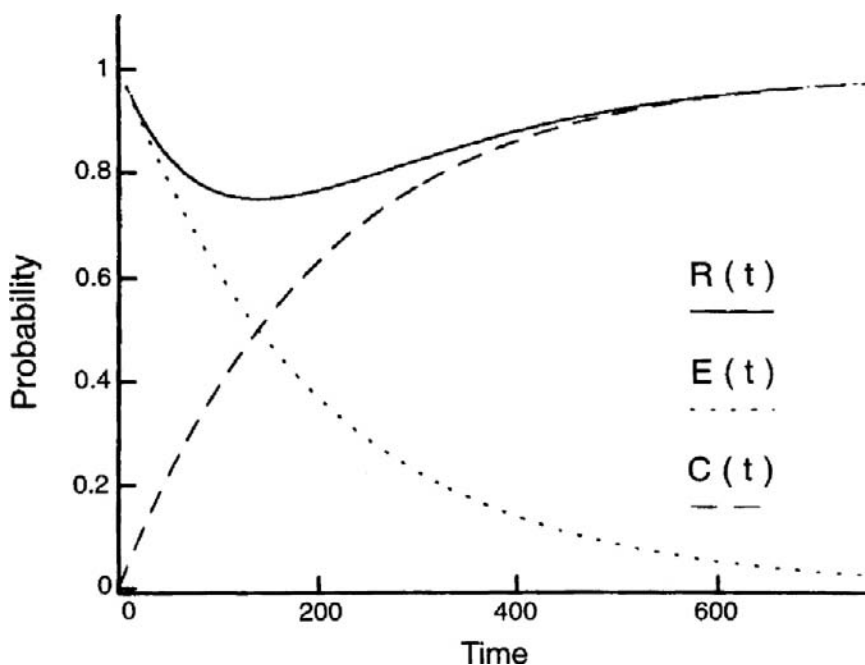
According to this theory, a single landmass (Pangaea) split about 200 million years ago, and separated into northern (Laurasia) and southern (Gondwanaland) supercontinents, which moved apart as a result of volcanic upwelling in the rift zone. About 135 million yrs ago India separated from Gondwanaland, moved northward, and eventually collided with Asia to form the Himalaya Mountains. Africa and South America separated about 65 million yrs ago, prior to the adaptive radiation of angiosperms and mammalian herbivores. South America eventually rejoined North America at the Isthmus of Panama, permitting the placental mammals that evolved in North America to invade and displace the marsupials (other than the generalized opossum) that had continued to dominate South America. Marsupials largely disappeared from the other continents as well, except for Australia, where they survived by virtue of their continued isolation. South American flora and fauna moved northward through tropical Central America. This process of continental movement explains the similarity of fossil flora and fauna among the Gondwanaland-derived continents, and the differences that are observed among biogeographic realms, e.g., *Nothofagus* forests in southern continents vs. *Quercus* forests in northern continents.

Continental movements result from the stresses placed on the Earth's crust by planetary motion. Fractures appear along the lines of greatest stress and are the basis for volcanic and seismic activity, two powerful forces that lead to the displacement of crustal masses. The mid-oceanic ridges and associated volcanism mark the original locations of the continents and preserve evidence of the direction and rate of continental movements. Rift valleys and fault lines typically provide depressions for the development of aquatic ecosystems. Mountain ranges develop along lines of collision and subsidence between plates and create elevational gradients and boundaries to dispersal. Volcanic and seismic activity represents a continuing disturbance in many ecosystems.

## B. Regional Patterns

Within biogeographic realms, a variety of biomes can be distinguished on the basis of their characteristic vegetation or aquatic characteristics (see [Chapter 2](#)). Much of the variation in environmental conditions that produce biomes at the regional scale is the result of global circulation patterns and topography. Mountain ranges and large rivers may be impassible barriers that limit the distribution of many species. Furthermore, mountains show relatively distinct elevational zonation of biomes (life zones). The area that is available as habitat becomes more limited at higher elevations. Mountaintops resemble oceanic islands in their degree of isolation within a matrix of lower elevation environments and are most vulnerable to climate changes that shift temperature and moisture combinations upward (Fig. 5.2).

Geographic ranges for most species are restricted by geographic barriers or by environmental conditions beyond their tolerance limits. Some insect species have broad geographic ranges that span multiple host ranges (e.g., the forest tent caterpillar, *Malacosoma disstria*, Parry and Goyer 2004), whereas others have ranges which are restricted to small areas (e.g., species endemic to cave ecosystems, Boecklen 1991). Those species with large geographic ranges often show considerable genetic variation among subpopulations, reflecting adaptations to regional environmental factors. For example,



**FIG. 7.2** Probability of species presence in an ecosystem ( $R$ ), as a function of probabilities of local extinction ( $E$ ) and colonization ( $C$ ) over time, for specified values of  $v$  = probability of colonization over time and  $\lambda$  = probability of extinction over time. From Naeem (1998) with permission from John Wiley & Sons.

Istock (1981) reported that northern and southern populations of a transcontinental North American pitcher-plant mosquito, *Wyeomyia smithii*, showed distinct genetically-based life history patterns. The proportion of third instars entering diapause increased with latitude, reflecting their adaptation to seasonal changes in habitat or food availability. Controlled crosses between northern and southern populations yielded high proportions of diapausing progeny from northern  $\times$  northern crosses, intermediate proportions from northern  $\times$  southern crosses and low proportions from southern  $\times$  southern crosses, for larvae that were subjected to conditions simulating either the northern or the southern photoperiod and temperature.

### C. Island Biogeography

Ecologists have been intrigued at least since the time of Hooker (1847, 1853, 1860) by the presence of related organisms on widely separated oceanic islands. Darwin (1859) and A. Wallace (1911) later interpreted this phenomenon as evidence of natural selection and speciation of isolated populations following separation or colonization from distant population sources. Simberloff (1969), Simberloff and Wilson (1969) and E. Wilson and Simberloff (1969) found that many arthropod species were capable of rapid colonization of experimentally defaunated islands. Although the **theory of island biogeography originally** was developed to explain patterns of equilibrium species richness among oceanic islands (MacArthur and Wilson 1967), the factors and processes that govern island patterns also explain the rates of species colonization and metapopulation dynamics (see below) among

isolated landscape patches (Cronin 2003, Hanski and Simberloff 1997, Leisnham and Jamieson 2002, Simberloff 1974, Soulé and Simberloff 1986).

Critics of this approach have argued that oceanic islands clearly are surrounded by habitat unsuitable for terrestrial species, whereas terrestrial patches may be surrounded by relatively suitable patches. Some terrestrial habitat patches may be more similar to oceanic islands than others, e.g., alpine tundra on mountaintops may represent substantially isolated habitats (Leisnham and Jamieson 2002), as are isolated wetlands in a terrestrial matrix (Batzer and Wissinger 1996), whereas disturbed patches in grassland may be less distinct (but see Cronin 2003). A second issue concerns the extent to which the isolated populations constitute distinct species or metapopulations of a single species (Hanski and Simberloff 1997). The resolution of this issue depends on the degree of heterogeneity and isolation among landscape patches and genetic drift among isolated populations over time.

#### D. Landscape and Stream Continuum Patterns

Within terrestrial biomes, gradients in climate and geographic factors, interacting with the patch scale of disturbances across landscapes, produce a shifting mosaic of habitat types that affects the distribution of populations (see Chapter 2). Local extinction of demes must be balanced by colonization of new habitats as they appear in order for a species to survive. However, colonists can arrive in terrestrial patches from various directions and distances. By contrast, the distribution of aquatic species is more constrained by the linear (single dimension) pattern of water flow. Colonists are more likely to come from upstream (if movement is governed by water flow) or downstream (flying adults), with terrestrial patches between stream systems being relatively inhospitable. Population distributions often are relatively distinct among drainage basins (watersheds), depending on the ability of dispersants to colonize new headwaters or tributaries. Hence, terrestrial and aquatic ecologists have developed different approaches to studying the spatial dynamics of populations, especially during the 1980s, when **landscape ecology** became a paradigm for terrestrial ecologists (M. Turner 1989) and **stream continuum** a paradigm for stream ecologists (Vannote et al. 1980).

The distribution of populations in terrestrial landscapes, stream continua and oceanic islands is governed to a large extent by probabilities of extinction vs. colonization in particular sites (Fig. 7.2, see Chapter 5). The dispersal ability of a species (see Chapters 2 and 5), the suitability of the patch, island or stream habitat, and its size and distance from the population source will determine the probability of colonization by a dispersing individual (Fig. 5.7). Island or patch size and distance from population sources influence the likelihood that an insect that is able to travel a given distance in a given direction will, in fact, contact that island or patch.

Patch suitability reflects the abundance of resources which are available to colonizing insects. Clearly, suitable resources must be present for colonizing individuals to survive and reproduce. However, preferences by colonizing individuals also may be important. Hanski and Singer (2001) examined the effect of two host plants, *Plantago* spp. and *Veronica* spp., which varied in their relative abundances among patches, on colonization by the Glanville fritillary butterfly, *Melitaea cinxia*. Colonization success was strongly influenced by the correspondence between relative composition of the two host plants and the relative host use by caterpillars in the source patches, i.e., colonizing butterflies strongly preferred to oviposit on the host plant they had used during larval development. The

average annual colonization rate was 5% for patches dominated by the host genus that was less common across the connecting landscape, and 15–20% for patches dominated by the host genus that was more common across the connecting landscape.

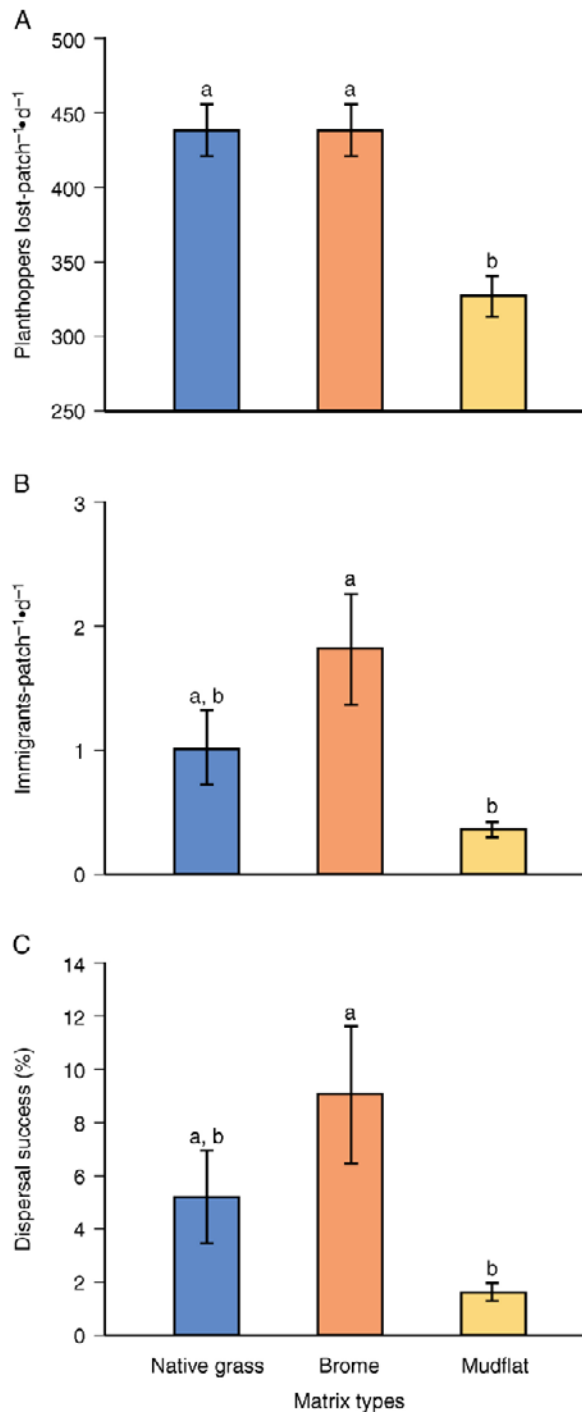
Individual capacities for sustained travel and for detection of cues that facilitate orientation determine colonization ability. Species that fly can travel long distances and traverse obstacles in an aquatic or terrestrial matrix better than can flightless species. Many small insects, including flightless species, catch air currents and are carried long distances at essentially no energetic cost to the insect. J. Edwards and Sugg (1990) reported that a variety of insects could be collected on montane glaciers far from the nearest potential population sources. Torres (1988) reported deposition, by hurricanes, of insect species from as far away as Africa on Caribbean islands.

On the other hand, many small, flightless species have limited capacity to disperse. Any factor that increases the time needed to reach a suitable habitat increases the risk of mortality due to predation, extreme temperatures, desiccation, or other factors. Distances of a few meters, especially across exposed soil surfaces, can effectively preclude dispersal by many litter species which are sensitive to heat and desiccation or are vulnerable to predation (Haynes and Cronin 2003). On the other hand, McIntyre and Wiens (1999) found that darkling beetles, *Eleodes obsoleta*, moved faster, over longer distances and in straighter lines through experimental landscapes with larger patch sizes, moved more slowly and spent more time in movement in heterogeneous landscapes, and showed longer residence time in intermediate-sized grass patches. Some aquatic species, e.g., Ephemeroptera, have limited life spans as adults to disperse among stream systems. D. Fonseca and Hart (2001) reported that larval black flies, *Simulium vittatum*, were least able to colonize preferred high velocity habitats in streams because of constraints on their ability to control settlement. Courtney (1985, 1986) reported that short adult life span was a major factor influencing the common selection of less suitable larval food plants for oviposition (see Chapter 3). Clearly, the distance between an island or habitat patch and the source population is inversely related to the proportion of dispersing individuals able to reach it (Fig. 5.7).

Island or patch size and complexity also influence the probability of successful colonization. The larger the patch (or the shorter its distance from the source population), the greater the proportion of the horizon it represents to a dispersing insect, hence the more likely that the insect will contact it. Patch occupancy rate increases with size (Cronin 2003). Similarly, the distribution of microsites within landscape or watershed patches affects the ability of dispersing insects to perceive and reach them. Basset (1996) reported that the presence of arboreal insects is influenced more strongly by local factors in complex habitats, such as tropical forests, and more strongly by regional factors in less complex habitats, such as temperate forests.

The composition of patches in a landscape matrix is as important as patch size and isolation in influencing population movement and distribution. Haynes and Cronin (2003) manipulated the composition of the matrix (mudflat, native non-host grasses, and exotic brome, *Bromus inermis*) which surrounded small patches of prairie cordgrass, *Spartina pectinata*, that were identical in size, isolation and host plant quality. Planthoppers, *Prokelisia crocea*, were marked and released into each host patch. Planthopper emigration rate was 1.3 times higher for patches that were surrounded by the two non-host grasses, compared to patches surrounded by mudflat (Fig. 7.3). Immigration rate was 5.4 times higher into patches surrounded by brome, compared to patches surrounded by mudflat, and intermediate in patches surrounded by native non-host grass. Patch occupancy and density increased with the proportion of the matrix that was composed of mudflat,





**FIG. 7.3** A) Effect of surrounding matrix on rate of planthopper loss from the cordgrass patch in which it was released, B) rate of planthopper immigration into satellite patches, and C) percentage of planthoppers emigrating from the central release patch that successfully immigrated into any of the eight surrounding patches. Vertical lines represent 1 SE. Bars with different letters are significantly different at  $P < 0.05$ . From Haynes and Cronin (2003) with permission from the Ecological Society of America.

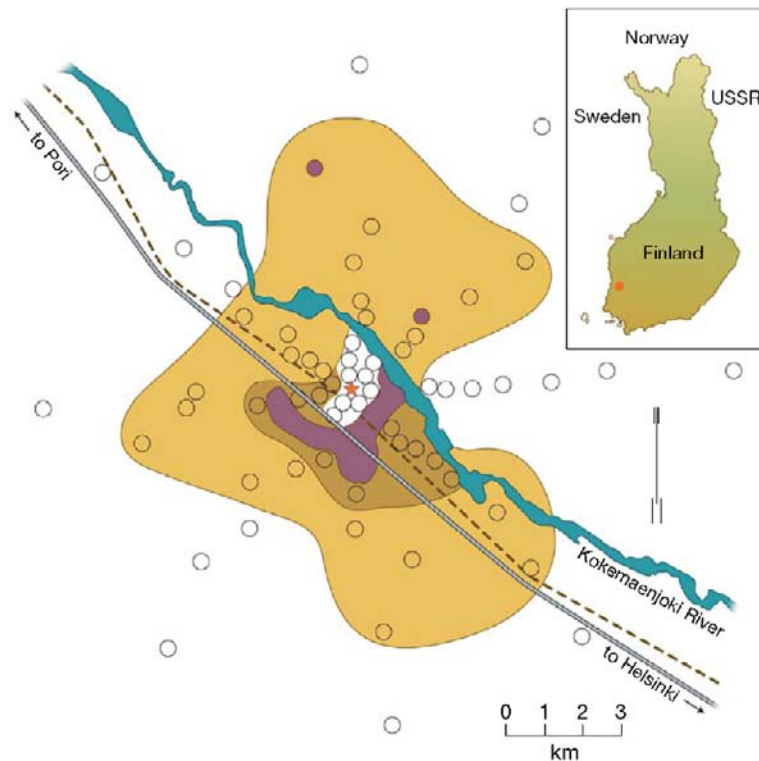
probably reflecting the relative inhospitability of the mudflat for dispersal compared to non-host grasses.

The increasing rate of dispersal during rapid population growth increases the number of insects moving across the landscape and the probability that some will travel a sufficient distance in a given direction to discover suitable patches. Therefore, population contribution to patch colonization and genetic exchange with distant populations is maximized during population growth.

## II. SPATIAL DYNAMICS OF POPULATIONS

As populations change in size, they also change in the spatial distribution of individuals. Population movement (epidemiology) across landscapes and watersheds (stream continuum) reflects the integration of physiological and behavioral attributes with landscape or watershed structure. Growing populations tend to spread across the landscape, as dispersal leads to colonization of new habitats, whereas declining populations tend to constrict into more or less isolated refuges. Isolated populations of irruptive or cyclic species can coalesce during outbreaks, thus facilitating genetic exchange.

Insect populations show considerable spatial variation in densities in response to geographic variation in habitat conditions and resource quality (Fig. 7.4). Variation can occur



**FIG. 7.4** Gradient in pine bark bug, *Aradus cinnamomeus*, densities with distance from the industrial complex (★) at Harjavalta, Finland. White circles = 0–0.50 bugs 100cm<sup>-2</sup>, yellow circles = 0.51–1.75 bugs 100cm<sup>-2</sup>, brown circles = 1.76–3.50 bugs 100cm<sup>-2</sup>, and purple circles = 3.51–12.2 bugs 100cm<sup>-2</sup>. From Heliövaara and Väisänen (1986) with permission from John Wiley & Sons.

over relatively small scales because of the small size of insects and their sensitivity to environmental gradients (e.g., Heliövaara and Väisänen 1993, Lincoln et al. 1993). The spatial representation of populations can be described across a range of scales from microscopic to global (Chapter 5). The pattern of population distribution can change over time as population size and environmental conditions change. Two general types of spatial variation are represented by the expansion of growing populations and by the discontinuous pattern of fragmented populations, or metapopulations.

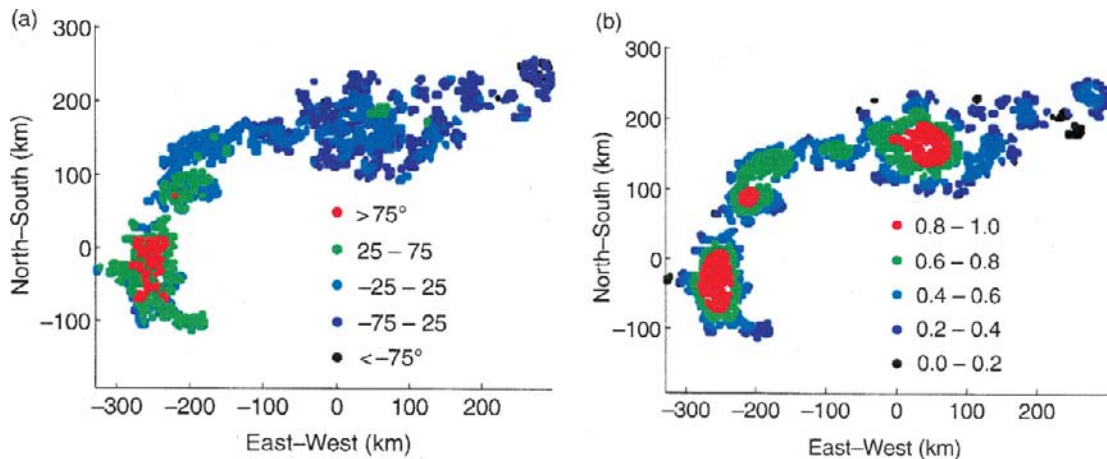
## A. Expanding Populations

Growing populations tend to spread geographically, as density-dependent dispersal leads to colonization of nearby resources. This spread occurs in two ways. First, diffusion from the origin, as density increases, produces a gradient of decreasing density toward the fringe of the expanding population. Grilli and Gorla (1997) reported that leafhopper, *Delphacodes kuscheli*, density was highest within the epidemic area and declined toward the fringes of the population. The difference in density between pairs of sampling points increased as the distance between the sampling points increased. Second, long distance dispersal leads to the colonization of vacant patches and “proliferation” of the population (Hanski and Simberloff 1997, Tobin et al. 2007). Subsequent growth and expansion of these new demes can lead to population coalescence, with local “hot spots” of superabundance that eventually disappear as resources in these sites are depleted and individuals disperse again.

The spread of demes from population refuges can be synchronous over landscapes, as described in Chapter 6. Alternatively, population expansion can occur as traveling waves, typified by partial synchrony with a gradient in the degree of population change (phase angle differences) as a function of distance (D. Johnson et al. 2004). For example, D. Johnson et al. (2004) showed that spatial dynamics of larch budmoth, *Zeiraphera diniana*, in the European Alps from 1961 to 1998 could be described as a series of traveling waves from multiple epicenters in favorable habitats, and that landscape heterogeneity (gradients and connectivity of habitat suitability) alone was capable of inducing waves (Fig. 7.5). Furthermore, population spread often occurs as pulses of range expansion under favorable environmental conditions (e.g., contact with patches of suitable habitat) interspersed with periods of relative stasis (D. Johnson et al. 2006).

The speed at which a population expands probably affects the efficiency of density-dependent regulatory factors. Populations that expand slowly may experience immediate density-dependent negative feedback in zones of high density, whereas induction of negative feedback may be delayed in rapidly expanding populations, as dispersal delays the increase in density. Therefore, density-dependent factors should operate with a longer time lag in populations that are capable of rapid dispersal during irruptive population growth.

The speed, extent and duration of population spread are determined by abiotic and biotic factors. Insect species that have annual life cycles often show incremental colonization and population expansion. Kozár (1991) reported that several insect species showed rapid expansion of their range northward in Europe during the 1970s, probably reflecting the warming temperatures that occurred during this period. Similarly, J. Jepsen et al. (2008) reported northward expansion of two cyclic geometrid moths, *Operophtera brumata* and *Epirrita autumnata*, that also was associated with continued warming during the past 20 years. Population expansion of spruce budworm, *Choristoneura fumiferana*,



**FIG. 7.5** a) Time-averaged phase angles (degree of population change) for larch budmoth, *Zeiraphera diniana*, spatial dynamics in the European Alps during 1961–1998. Highest phase angles (red) indicate epicenter locations and lower phase angles indicate areas into which the population subsequently spread. b) Relative connectivity measures of budmoth habitat across the Alps based on Gaussian dispersal with  $\alpha=25$ . Connectivity was rescaled so that the location with highest connectivity had a value of 1. From D. Johnson et al. (2004) with permission from John Wiley & Sons.

western harvester ant *pogonomyrmex occidentalis*, and grasshoppers during outbreaks are associated with warmer, drier periods (Capinera 1987, DeMers 1993, Greenbank 1963). Environmental change or disturbances can terminate the spread of sensitive populations. Frequently disturbed systems, such as crop systems or streams subject to annual scouring, limit population spread to the intervals between recolonization and subsequent disturbance (Matthaei and Townsend 2000, Reice 1985).

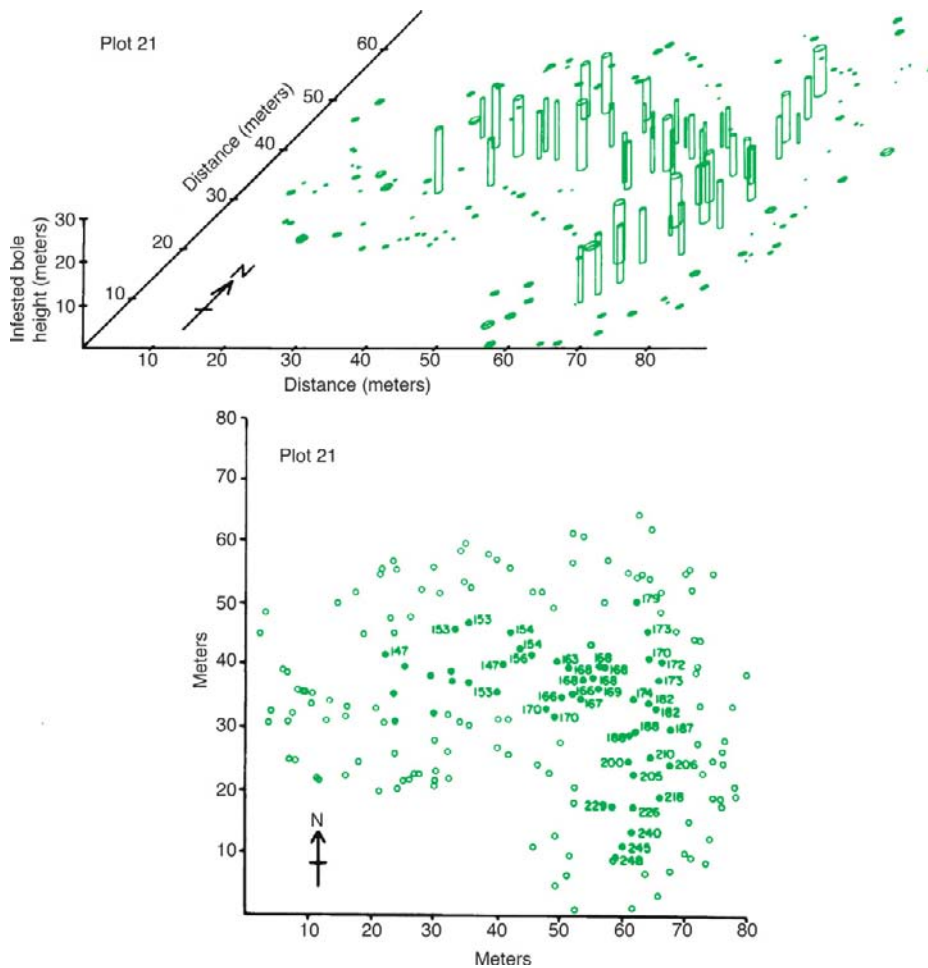
Populations of species with relatively slow dispersal rates may expand only to the limits of a suitable patch during the favorable period. Spread beyond the patch also depends on the suitability of neighboring patches (Baum et al. 2004, Haynes and Cronin 2003, D. Johnson et al. 2004, Liebhold and Elkinton 1989). Populations can spread more rapidly and extensively across landscapes dominated by host species, such as agricultural and silvicultural systems, than in more heterogeneous systems in which the presence of unsuitable patches limits spread (Haynes and Cronin 2003, D. Johnson et al. 2004, Onstad et al. 2003, Schowalter and Turchin 1993).

Finally, the status of competitors, predators or parasites with which the expanding population comes into contact can limit further expansion. Lounibos et al. (2003) examined factors that were responsible for the higher abundance of invasive container mosquitoes, *Aedes albopictus*, in areas where two species of native *Wyeomyia* mosquitoes are absent. Tests in experimental containers revealed that *Wyeomyia* larvae did not deter oviposition by *A. albopictus*. However, fourth instar *Wyeomyia* larvae (but not first instar larvae) significantly reduced the growth and survival of *A. albopictus* larvae, indicating that inter-specific larval interaction determined the geographic distribution of *A. albopictus*.

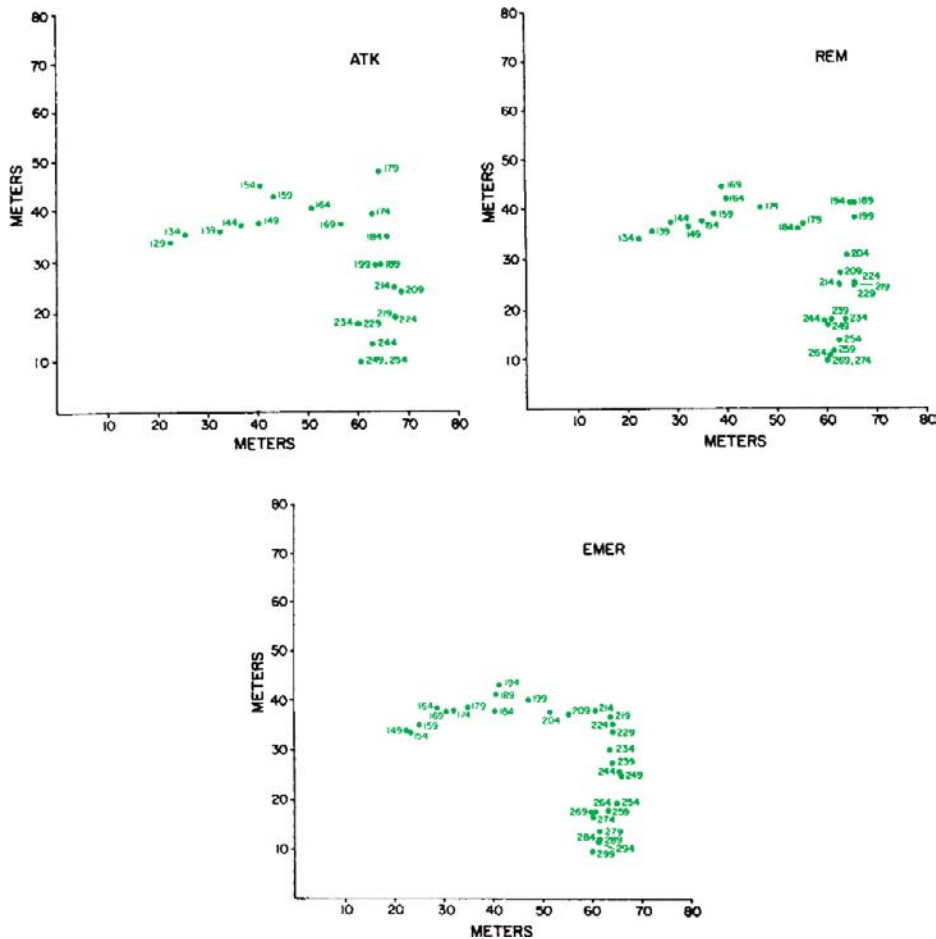
The direction of population expansion also depends on several factors. The direction of population spread is constrained by environmental gradients, by wind or water flow, and by the presence of unsuitable patches. Gradients in temperature, moisture or chemical concentrations restrict the directions in which insect populations can spread, based on their ranges of tolerance to these factors (Chapter 2). Even relatively homogeneous environments, such

as enclosed stored grain, are subject to gradients in internal temperatures that affect spatial change in granivore populations (Flinn et al. 1992). Furthermore, the direction and flow rate of wind or water have considerable influence on insect movement. Insects with limited capability to move against air or water currents move primarily downwind or downstream, whereas those capable of movement toward attractive cues move primarily upwind or upstream. Insects that are sensitive to stream temperature, flow rate, or chemistry may be restricted to spread along linear stretches of the stream. P. Jepson and Thacker (1990) reported that recolonization of agricultural fields by carabid beetles dispersing from population centers was delayed by extensive use of pesticides in neighboring fields.

Schowalter et al. (1981b) examined the spread of southern pine beetle, *Dendroctonus frontalis*, populations in east Texas (Fig. 7.6). They described the progressive colonization



**FIG. 7.6** Spatial and temporal pattern of spread of a southern pine beetle population in east Texas during 1977. In the upper figure, cylinders are proportional in size to size of colonized trees; ellipses represent uncolonized trees within 10 m of colonized trees. In the lower figure, Julian dates of initial colonization are given for trees colonized (filled circles) after sampling began. Open circles represent uncolonized trees within 10 m of colonized trees. From Schowalter et al. (1981b) with permission from the Society of American Foresters.



**FIG. 7.7** Centroids of colonization (ATK), re-emergence (REM) and emergence (EMER), by Julian date, for the southern pine beetle population in Figure 7.6. From Schowalter et al. (1981b) with permission from the Society of American Foresters.

of individual trees or groups of trees through time by computing centroids of colonization activity on a daily basis (Fig. 7.7). A centroid is the center of beetle mass (numbers), calculated as the weighted abundance of beetles among the x,y coordinates of colonized trees at a given time. The distance between centroids on successive days was a measure of the rate of population movement (Fig. 7.7).

Populations moved at a rate of  $0.9\text{m/da}^{-1}$  primarily in the direction of the nearest group of available trees. However, since southern pine beetle populations were generally sparse during the period of this study, indicating relatively unfavorable conditions, this rate may be near the minimum necessary to sustain population growth. The probability that a tree would be colonized depended on its distance from currently occupied trees. Trees within 6 m of sources of dispersing beetles had a 14–17% probability of being colonized, compared to a probability of less than 4% for trees further than 6 m from sources of dispersing beetles. Population spread in most cases ended at canopy gaps where no trees were available within 6 m. However, one population successfully crossed a larger gap encountered at peak abundance (Fig. 7.6), indicating that a sufficiently large number

of beetles dispersed across the gap to ensure aggregation on suitable trees and sustained population spread.

Population spread in this species may be facilitated by colonization experience and cooperation between cohorts of newly emerging beetles and beetles “re-emerging” from densely colonized hosts. Many beetles re-emerge after laying some eggs, especially at high colonization densities under outbreak conditions, and seek less densely colonized trees in which to lay their remaining eggs. The success of host colonization by southern pine beetles depends on rapid attraction of sufficiently large numbers to overwhelm host defenses (see Chapter 3). For a given day, the centroid of colonization was, on average, twice as far from the centroid of new adults dispersing from brood trees as from the centroid of re-emerging beetles (Fig. 7.7). This pattern suggested that re-emerging beetles select the next available trees and provide a focus of attraction for new adults dispersing from further away.

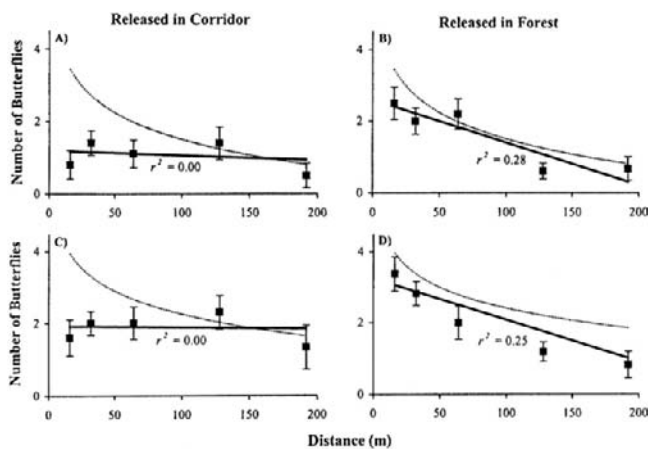
Related research has reinforced the importance of host tree density for population spread of southern pine beetle and other bark beetles (Amman et al. 1988, M. Brown et al. 1987, R.G. Mitchell and Preisler 1992, Sartwell and Stevens 1975). Schowalter and Turchin (1993) demonstrated that patches of relatively dense, pure pine forest are essential to the growth and spread of southern pine beetle populations from experimental refuge trees (Fig. 6.7). Experimentally established founding populations spread from initially-colonized trees surrounded by dense pure pine forest, but not from trees surrounded by sparse pines or pine/hardwood mixtures.

Under suitable conditions, insect populations can spread very rapidly. Reay-Jones et al. (2007) used pheromone-baited traps to measure the spread of the invasive Mexican rice borer, *Eoreuma loftini*, through the Texas rice belt from 2000 to 2005. These data, and the date of first appearance of this species by county since 1980 indicated an average rate of spread of 23 km yr<sup>-1</sup>. Henne et al. (2007) measured the rate of spread of a phorid fly, *Pseudacteon tricuspis*, that was introduced as a biological control agent for the red imported fire ant, *Solenopsis invicta*, in Louisiana during the first six years after its release. The annual rate of spread was slow during the first two years, as the fly population became established, then increased rapidly during years 3–4 and reached an asymptote of 15–25 km yr<sup>-1</sup> during years 5–6.

A critical aspect of population spread is the degree of continuity of hospitable resources or patches on the landscape. As described above for the southern pine beetle, unsuitable patches can interrupt population spread unless population density or growth is sufficient to maintain high dispersal rates across inhospitable patches. Similarly, Meisel (2006) reported that army ants, *Eciton burchellii*, in Costa Rica were restricted to forest fragments, and consistently avoided entering pastures, where midday temperatures reached >50 °C; ants survived <3 min at this temperature and only 18 min at 43 °C. Heterogeneous landscapes composed of a variety of patch types force insects to expend their acquired resources on detoxifying less acceptable resources or searching for more acceptable resources. Therefore, heterogeneous landscapes should tend to limit population growth and spread, whereas more homogeneous landscapes, such as large areas devoted to plantation forestry, pasture grasses, or major crops, provide conditions more conducive to sustained population growth and spread. The particular composition of landscape mosaics may be as important as patch size and isolation for insect movement and population distribution (Haynes and Cronin 2003). Furthermore, herbivores and predators may respond differently to landscape structure. Herbivores were more likely to be absent from small patches than large patches, whereas predators were more likely to be absent from more isolated

patches than from less isolated patches in agricultural landscapes in Germany (Zabel and Tschardt 1998).

Corridors or stepping stones (small intermediate patches) can facilitate population spread among suitable patches across otherwise unsuitable patches (Fig. 7.8). Haddad et al. (2003) found that ten taxa, representing plants, insects and mammals, consistently showed greater movement toward patches that were connected by corridors or stepping stones than toward unconnected patches. Populations of the western harvester ant, *Pogonomyrmex occidentalis*, do not expand across patches subject to frequent anthropogenic disturbance (specifically, soil disruption through agricultural activities) but are able to expand along well-drained, sheltered roadside ditches (DeMers 1993). Roads often provide a disturbed habitat with conditions suitable for dispersal of weedy vegetation and associated insects among disturbed patches. Roadside conditions may also increase plant suitability for herbivorous insects and facilitate movement across landscapes that are fragmented by roads (Spencer and Port 1988, Spencer et al. 1988). However, for some insects the effect of corridors and stepping stones may depend on the composition of the surrounding matrix. Baum et al. (2004) reported that experimental corridors and stepping stones significantly increased colonization of prairie cordgrass, *S. pectinata*, patches by planthoppers, *P. crocea*, in a low resistance matrix composed of exotic, non-host brome, *B. inermis*, that is conducive to planthopper dispersal, but not in a high resistance matrix composed of mudflat that interferes with planthopper dispersal, relative to control matrices without corridors or stepping stones. Fried et al. (2005) found that the edge-following behavior of house flies, *Musca domestica*, results in diversion into patches with corridors.



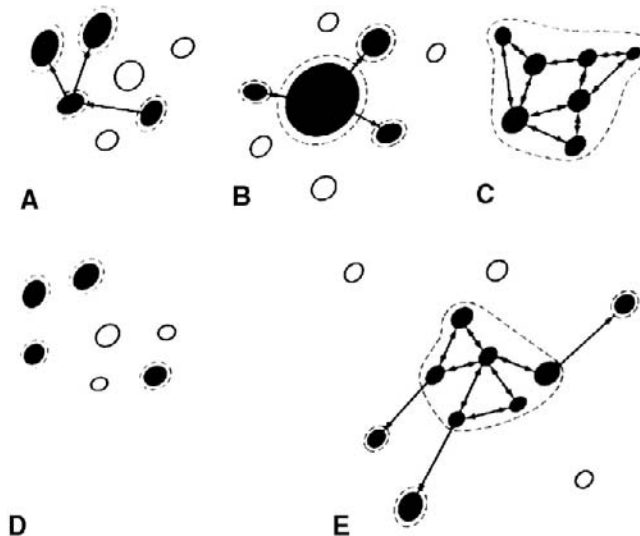
**FIG. 7.8** Patch colonization by *Junonia coenia*, an open habitat specialist, relative to distance from release point. A) number released in open-field corridors that colonized patches adjacent to their release point; B) number released in forest that colonized patches adjacent to their release point ( $p=0.001$ ); C) number released in corridors that colonized any patch; D) number released in forest that colonized any patch ( $p=0.001$ ). Dashed lines are fit to a null model based on straight-line movement in a randomly-chosen direction. From Haddad et al. (2000) with permission from John Wiley and Sons.



An important consequence of rapid population growth and dispersal is the colonization of marginally suitable resources or patches, where populations could not persist in the absence of continuous influx. Whereas small populations of herbivores, such as locusts or bark beetles, may show considerable selectivity in their acceptance of potential hosts, rapidly growing populations often eat all potential hosts in their path. Dense populations of the range caterpillar, *Hemileuca oliviae*, disperse away from population centers, as grasses are depleted, and form an expanding ring, leaving denuded grassland in their wake. Landscapes that are conducive to population growth and spread, because of widespread homogeneity of resources, facilitate colonization of surrounding patches and more isolated resources because of the large numbers of dispersing insects. Epidemic populations of southern pine beetles, generated in the homogenous pine forests of the southern Coastal Plain during the drought years of the mid-1980s, produced sufficient numbers of dispersing insects to discover and kill most, otherwise resistant, pitch pines, *Pinus rigida*, in the southern Appalachian Mountains.

## B. Metapopulation Dynamics

A metapopulation is a population composed of relatively isolated demes maintained by some degree of dispersal among suitable patches (Hanski and Simberloff 1997, Harrison and Taylor 1997, Levins 1970, see Chapter 5). Metapopulation structure can be identified at various scales (Massonnet et al. 2002), depending on the scale of distribution and the dispersal ability of the population (Fig. 7.9). For example, metapopulations of some sessile, host-specific insects, such as scale insects (Edmunds and Alstad 1978), can be distinguished among host plants at a local scale, although the insect occurs commonly



**FIG. 7.9** Diagrammatic representation of different metapopulation models. Filled circles are occupied patches; open circles are unoccupied patches; dotted lines are boundaries of local populations; arrows represent dispersal. A) classic (Levins) model of dispersal among demes, B) island biogeography model with the mainland providing a source of colonists, C) a network of interacting demes, D) a non-equilibrium metapopulation with little capacity for recolonization of vacant patches, and E) an intermediate case combining features of A–D. From Harrison and Taylor (1997).

over a wide geographic range. Local populations of black flies (Simuliidae) can be distinguished at the scale of isolated stream sections characterized by particular substrate, water velocity, temperature, proximity to lake outlets, etc., whereas many species occur over a broad geographic area (e.g., P. Adler and McCreddie 1997, Hirai et al. 1994). Many litter-feeding species occur throughout patches of a particular vegetation type, but that particular vegetation type and associated populations are fragmented at the landscape scale (Grove 2002).

Metapopulation structure is most distinct where patches of suitable habitat or food resources are distinct and isolated due to natural environmental heterogeneity (e.g., desert or montane landscapes) or to anthropogenic fragmentation. The spatial pattern of metapopulations reflects a number of interacting factors, including patch size, isolation, and quality (e.g., resource availability and disturbance frequency), and insect dispersal ability (Fleishman et al. 2002, Frouz and Kindlmann 2006, Summerville et al. 2002) and largely determines gene flow, species viability and, perhaps, evolution of life history strategies (e.g., Colegrave 1997). Hence, attention to spatially structured populations has increased rapidly in recent years.

Metapopulation structure can develop in a number of ways (Fig. 7.9). One is through the colonization of distant resources, and subsequent population development, which occurs during expansion of the source population (see above). A second is through the isolation of population remnants during population decline. A third represents a stable population structure in a heterogeneous environment, in which vacant patches are colonized as local extinction occurs in other patches.

The colonization of new patches as dispersal increases during population growth is an important mechanism for initiating new demes and facilitating population persistence on the landscape. The large number of dispersants that are generated during rapid population growth maximizes the probability that suitable resources will be colonized over a considerable area and that more founders will infuse the new demes with greater genetic heterogeneity (Hedrick and Gilpin 1997). Species with ruderal life histories generally exhibit considerable dispersal capacity and often arrive at sites quite remote from their population sources (J. Edwards and Sugg 1990). Such species quickly find and colonize disturbed sites and represent a widely occurring “weedy” fauna. By contrast, species with competitive strategies show much slower rates of dispersal and may travel shorter distances, consistent with their more stable population sizes and adaptation to more stable habitats (St. Pierre and Hendrix 2003). Such species can be threatened by rapid changes in environmental conditions that exterminate demes more rapidly than new demes are established (Hanski 1997, Hedrick and Gilpin 1997).

If conditions for population growth continue, the outlying demes may grow and coalesce with the expanding source population. This process contributes to more rapid expansion of growing populations than would occur only as diffusive spread at the fringes of the source population. A well-known example of this is seen in the pattern of gypsy moth, *Lymantria dispar*, population expansion during outbreaks in eastern North America (see Box at the beginning of this chapter). New demes appear first on ridgetops in the direction of the prevailing wind, because of the wind-driven dispersal of ballooning larvae. These demes grow and spread downslope, merging in the valleys. Similarly, swarms of locusts may move great distances to initiate new demes beyond the current range of the population (Lockwood and DeBrey 1990).

As a population retreats during decline, subpopulations typically persist in isolated refuges, establishing the post-outbreak metapopulation structure. Refuges are

characterized by relatively low population densities, which escape the density-dependent decline of the surrounding population. These surviving demes may remain relatively isolated until the next episode of population growth; they represent the sources of the next population expansion. The existence and distribution of refuges is extremely important to population persistence. For example, bark beetle populations typically persist as scattered demes in isolated, lightning-struck, diseased or injured trees which can be colonized by small numbers of beetles (Flamm et al. 1993). Such trees appear on the landscape with sufficient frequency and proximity to beetle refuges that endemic populations are maintained (Coulson et al. 1983). Croft and Slone (1997) and W. Strong et al. (1997) reported that predaceous mites quickly find colonies of spider mites. New leaves on expanding shoots provide important refuges for spider mite colonists by increasing their distance from predators associated with source colonies.

If suitable refuges are unavailable, too isolated, or of limited persistence, a population may decline to extinction. Under these conditions, the numbers and low heterozygosity of dispersants generated by remnant demes are insufficient to ensure viable colonization of available habitats (Fig. 5.8). For most species, life history strategies represent successful adaptations that balance population processes with natural rates of patch dynamics, i.e., the rates of appearance and disappearance (turnover) of suitable patches across the landscape. For example, Leisnham and Jamieson (2002) reported that immigration and emigration rates of the mountain stone weta, *Hemideina maori*, were equivalent (0.023 per capita). However, anthropogenic activities have dramatically altered natural rates and landscape pattern of patch turnover and put many species at risk of extinction (Fielding and Brusven 1993, Lockwood and DeBray 1990, Vitousek et al. 1997).

Lockwood and DeBray (1990) suggested that the loss of critical refuges as a result of anthropogenically altered landscape structure led to the extinction of a previously widespread and periodically irruptive grasshopper species. The Rocky Mountain grasshopper, *Melanoplus spretus*, occurred primarily in permanent breeding grounds in valleys of the northern Rocky Mountains, but was considered to be one of the most serious agricultural pests in western North America prior to 1900 (C. Riley 1878, 1883). Large swarms periodically migrated throughout the western U. S. and Canada during the mid-1800s, destroying crops over areas as large as 330,000 km<sup>2</sup> before declining precipitously (C. Riley 1883). The frequency and severity of outbreaks declined during the 1880s, and the last living specimen was collected in 1902. Macroscale changes during this period (e.g., climate changes, disappearance of Native Americans and bison, and introduction of livestock) do not seem adequate by themselves to explain this extinction. However, the population refuges (breeding ground) for this species during the late 1800s were riparian habitats (C. Riley 1883) where agricultural activity, e.g., tillage, irrigation, trampling by cattle, introduction of non-native plants and birds, was concentrated. Hence, competition between humans and grasshoppers for refugia with suitable oviposition and nymphal development sites may have been the primary factor that led to the extinction of *M. spretus* (Lockwood and DeBrey 1990).

Stable metapopulation structures are maintained by balance between source and sink habitats on the landscape. Frouz and Kindlmann (2006) described patterns of colonization and extinction for a soil-dwelling chironomid fly, *Smittia atterima*, in the Czech Republic. Larvae were most abundant in open, disturbed habitats. However, source habitats were vulnerable to desiccation and local extinction of larvae during summer. Smaller populations that were produced in surrounding, more densely vegetated areas tended to

be more stable. Dispersing individuals from these sink habitats subsequently recolonized the source habitats, maintaining a stable population distribution.

### III. HABITAT CONNECTIVITY

As described above, habitat homogeneity facilitates population spread over landscapes. However, habitats often are heterogeneous over landscapes, and unsuitable patches can interrupt population spread (Onstad et al. 2003). In such cases, the availability of corridors connecting otherwise isolated habitat patches are critical to population growth and spread (Haddad et al. 2003). For example, roads and other disturbed corridors facilitate movement of species associated with disturbed habitats (DeMers 1993, Haddad 1999, 2000, Spencer and Port 1988, Spencer et al. 1988); corridors of undisturbed habitat connecting undisturbed patches are necessary to ensure adequate dispersal of species characterizing undisturbed habitats (Collinge 2000, Várkonyi et al. 2003).

Várkonyi et al. (2003) used mark–recapture techniques to track the movement of two species of noctuid moths. *Xestia speciosa*, is a habitat generalist that can be found in natural and managed spruce forests and also in pine-dominated forest throughout Finland; *Xestia fennica*, a species more restricted to natural spruce forests in northern Finland. Both species preferred to move along spruce forest corridors, and avoided entering the matrix of clearcuts and regenerating forest. Movement of *X. speciosa* generally covered longer distances, whereas that of *X. fennica* was characterized by shorter distances confined within corridors. However, *X. fennica* was capable of longer-distance dispersal across the matrix.

Haddad (1999, 2000) demonstrated that corridors between patches of open habitat, embedded in pine, *Pinus spp.*, forest, significantly increased interpatch dispersal of buckeye, *Junonia coenia*, and variegated fritillary, *Euptoieta claudia*, butterflies. Haddad and Baum (1999) found that three butterfly species (*J. coenia*, *E. claudia* and cloudless sulphur, *Phoebis sennae*) that characterized open habitats reached higher population densities in patches connected by corridors than in isolated patches; a fourth species, the spicebush swallowtail, *Papilio troilus*, did not show any preference for open vs. pine habitat, and did not differ in density between connected or isolated patches. Collinge (2000) also reported variable effects of corridors on grassland insect movement. Corridors slightly increased the probability of colonization by less vagile species, but did not affect recolonization by rare species. One of three focus species significantly preferred corridors, whereas the other two moved independently of corridors. These studies indicated that corridors may facilitate movement of organisms among patches, but their effect depends on species characteristics, landscape context, patch size, corridor length, and environmental variation.

Riparian habitats provide unique conditions for specialized terrestrial assemblages and facilitate the movement of some terrestrial species through fragmented landscapes (Rykken et al. 2007a, b, Sabo et al. 2005). Riparian habitat widths of at least 30 m on either side of streams appear necessary to provide an adequate corridor effect (Rykken et al. 2007a, b). Cartron et al. (2003) and Lambeets et al. (2008) found that carabid beetle abundance and species richness were significantly higher in riparian forests subject to periodic flooding, compared to non-flooded sites, indicating the importance of flooding to the maintenance of habitat suitability for some riparian taxa. However, the distinct habitat conditions that characterize riparian corridors may not be suitable for dispersing upland species in areas with steep elevational gradients.

Riparian corridors also may be necessary to maintain habitat conditions for populations of some stream invertebrates. Reduction in riparian canopy cover significantly increases water temperature, especially in the summer (Kiffney et al. 2003, Rykken et al. 2007b). Davies and Nelson (1994) found that mayfly (Ephemeroptera) and stonefly (Plecoptera) densities in streams were significantly and positively correlated with the width of adjacent riparian forest buffers in Tasmania, mirroring the effects of buffer width on stream temperature. Changes in riparian composition, e.g., deciduous vs. evergreen, also influence seasonal gradients in temperature; stonefly densities were significantly higher in streams that were bordered by young deciduous forest, compared to streams through old-growth coniferous forest (Fraday et al. 2007).

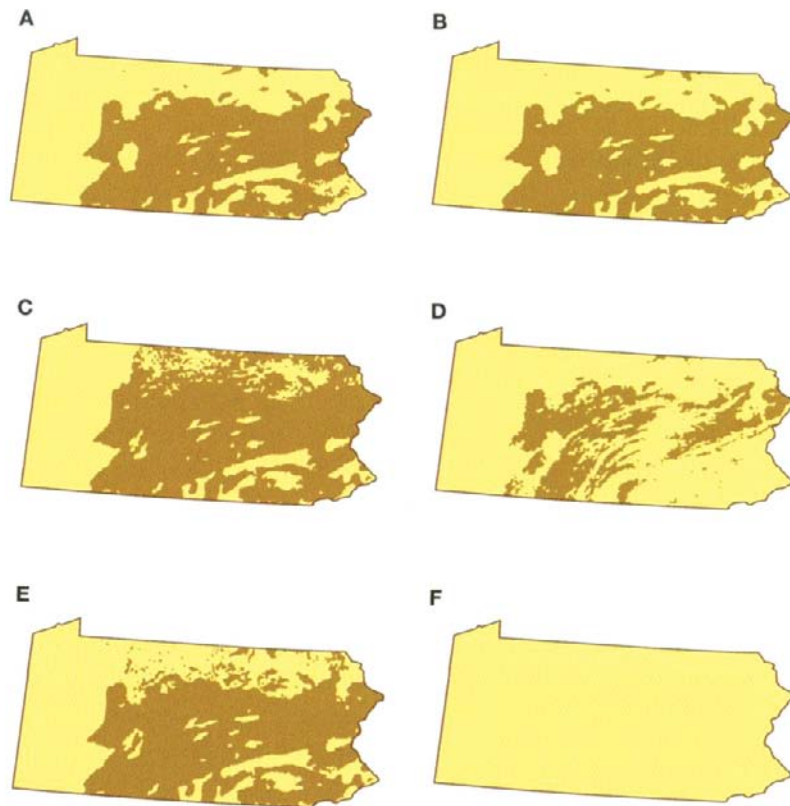
Some insect species show dramatic population displacement among habitats. Immatures of many aquatic species emerge en masse and disperse through intervening terrestrial habitats to reproduce in distant aquatic habitats (e.g., Gratton et al. 2008). Populations of monarch butterflies, *Danaus plexippus*, and other daneids are displaced thousands of kilometers seasonally between their summer habitat in northern temperate zones and their overwintering habitat in the tropics (Matthews and Matthews 2010). Similarly, locust swarms are displaced thousands of kilometers from their source to new habitats where breeding establishes new population centers (Gunn et al. 1948, Rainey 1963, C. Riley 1878).

#### IV. ANTHROPOGENIC EFFECTS ON SPATIAL DYNAMICS

The disappearance of *M. spretus* indicates the vulnerability to extinction of even cyclically abundant species when populations decline to near or below extinction thresholds as a result of habitat loss (see Chapter 6). Species persist to the extent that their reproductive and dispersal capabilities are adapted to the frequency and scale of these changes. Species which are adapted to relatively unstable habitats typically have higher reproductive rates and greater dispersal capabilities than do species which are adapted to more stable habitats. Hence, human-dominated ecosystems are likely to favor population growth of species which are adapted to disturbed habitats, at the expense of those adapted to more stable habitats.

Human activities affect the spatial dynamics of populations in several ways. Widespread planting of commercial crops often has facilitated spread of associated herbivores, e.g., Colorado potato beetle, *Leptinotarsa decemlineata*, and cotton boll weevil, *Anthonomus grandis* (see Chapter 4). Climate changes eventually will force many species to shift their geographic ranges or face extinction, as changing temperatures and humidities exceed their tolerance ranges or alter energy balance within their current ranges (Franklin et al. 1992, Kozár 1991, Rubenstein 1992) (Fig. 5.2). D. Williams and Liebhold (2002) projected that the distribution of the southern pine beetle would shift northward and expand in areas with warming climate, whereas mountain pine beetle, *Dendroctonus ponderosae*, distribution would move to higher elevations with shrinking area. D. Williams and Liebhold (1995) found that some climate change scenarios predicted larger areas of defoliation by gypsy moth, whereas other scenarios predicted smaller areas of defoliation (Fig. 7.10).

Fragmentation of terrestrial ecosystems, alteration and pollution of aquatic ecosystems, and redistribution of species arguably are the most serious and immediate threats to ecosystems worldwide (Samways 1995). Patch scale, distribution, and abruptness of edges have been altered as a result of habitat fragmentation. This has been particularly evident for wetlands and grasslands. Wetlands historically occupied large portions of



**FIG. 7.10** Potential outbreak areas of gypsy moth in Pennsylvania under climate change scenarios. A) current temperature and precipitation, B) a 2°C increase, C) a 2°C increase and 0.5 mm d<sup>-1</sup> precipitation increase, D) a 2°C increase and 0.5 mm d<sup>-1</sup> precipitation decrease, E) GISS model, F) GFDL model. From D. Williams and Liebhold (1995) with permission from the Entomological Society of America.

many floodplains but have been virtually eliminated as a result of draining, filling and stream channeling for urban and agricultural developments. Grasslands have been fragmented severely worldwide because of their suitability for agricultural uses. Reservoirs have altered drainage characteristics and reduced the distances between lake ecosystems. Industrial and agricultural pollution threatens many aquatic species. A large number of vagrant species (including various crops and “weeds”, rodents, and livestock, as well as insects and pathogens) have been transported, intentionally and unintentionally, far beyond their natural ranges by human activities. These exotic species have altered the structure and function of their new ecosystems significantly.

### A. Fragmentation

Fragmentation is the conversion of contiguous habitat into patches of different habitats or land uses. Habitat fragmentation is especially deleterious to species which are adapted to relatively stable ecosystems (e.g., Samways 1995) and to rare species (Summerville and Crist 2001). Such species typically are less adapted to rapid or long distance dispersal, hence may be less able to recolonize vacant or new habitats (resulting from fragmentation)

across inhospitable patches, compared to ruderal species adapted to long-distance colonization of disturbed habitats (St. Pierre and Hendrix 2003, Powell and Powell 1987, see Chapter 5). Furthermore, insects will not be able to colonize new habitat patches successfully until their hosts are established.

A growing number of species is becoming vulnerable to extinction as populations become more isolated in fragmented habitats (Boecklen 1991, M. Wilson et al. 1997). Examples include a number of butterfly species, the American burying beetle, *Necrophorus americanus*, and a number of aquatic and cave-dwelling species (e.g., Boecklen 1991, Hanski and Simberloff 1997, C. Thomas and Hanski 1997, M. Wilson et al. 1997).

Old-growth (500–1000 yr old) conifer forests in Pacific Northwestern North America were fragmented substantially by clearcut harvesting over a 50 yr period (1940–1990). The forest landscape changed from about 75% old-growth to about 75% of stands that were less than 50 yrs old. A significant proportion of species associated with old-growth forest now exist as relatively small, isolated, and declining populations in a matrix of apparently inhospitable young forest (N. Christensen et al. 2000). Schowalter (1995) found that 70% of arboreal arthropod species in old-growth conifer forests in western Oregon were not present in adjacent young (20 yrs old) conifer plantations. Predators and detritivores were particularly affected. Similarly, Powell and Powell (1987) found that flower visitation by male euglossine bees declined following forest fragmentation, even in the 100 ha fragment size, and was proportional to fragment size, indicating that very large areas of forest are necessary to maintain viable population sizes for some species.

The degree of fragment isolation affects colonization and genetic variability. Steffan-Dewenter and Tschardt (1999) demonstrated that the abundance of pollinating bees and seed production declined with increasing isolation (distance) of experimental mustard, *Sinapis arvensis*, and radish, *Raphanus sativus*, plants from intact grassland in Germany. Steffan-Dewenter et al. (2002) further demonstrated that the abundance and diversity of bees increased as the proportion of surrounding habitat in a semi-natural condition increased. Krawchuk and Taylor (2003) studied patterns of abundance of three dipterans, *W. smithii* (Culicidae), *Metriocnemus knabi* (Chironimidae), and *Fletcherimyia fletcheri* (Sarcophagidae) that inhabited pitcher plants, *Sarracenia purpurea*, in western Newfoundland, Canada. For all three insect species, habitat configuration (patch size and isolation) was more important than its total area, but the relative importances of patch size vs. isolation changed with spatial scale. Patch size was more important at the scale of movement and survival of individuals, whereas patch isolation was more important at the scale of matrix configuration and metapopulation dynamics.

Edges between patches are particularly pronounced in anthropogenic landscapes and affect dispersal of many species. Natural gradients of climate and geology interacting with disturbances produce relatively large patches, with broad transition zones (ecotones), between patches, that dampen interference by one patch on the environmental conditions of another. By contrast, human land use practices tend to produce smaller patches with abrupt edges, e.g., distinct agricultural monocultures within fenced boundaries, plowed edges against grasslands, harvested and regenerating plantations against mature forests, and greater edge density, i.e., edge perimeter length per ha (e.g., Radeloff et al. 2000). These distinct edges substantially influence the environmental conditions of the adjacent patches. For example, an edge of tall trees along an abrupt boundary with an adjacent plantation of short trees is exposed to much greater insolation and airflow, depending on edge orientation, leading to higher temperatures, lower humidities, and greater vulnerability to windthrow than prevailed when the trees along the edge were buffered by surrounding

trees. J. Chen et al. (1995) discovered that microclimatic gradients (higher temperature, lower humidity) extended for 180–480 m into old-growth Douglas-fir, *Pseudotsuga menziesii*, forests from clearcut edges, affecting habitat conditions for associated organisms. They concluded that forest patches of less than 64 ha would be completely compromised by external environmental conditions, i.e., would be characterized entirely as edge habitat rather than as interior forest habitat. Similarly, grasslands that have been overgrazed by livestock within fenced boundaries expose soil to desiccation, leading to the death of surrounding vegetation and an increasing area of desertification (e.g., Foley et al. 2003a, Schlesinger et al. 1990, see Chapter 11 and Fig. 2.6E). However, different effects on horizontal gradients of light, air temperature, relative humidity, soil moisture and wind speed were found for edges created by narrow, linear openings for highways, powerlines and streams, indicating that the nature of the edge, as well as its width, determines the magnitude of effect on microclimatic conditions (Pohlman et al. 2007).

Insects are sensitive to these edge effects. Haynes and Cronin (2003) found that planthoppers, *P. crocea*, accumulated along edges, compared to interior, of prairie cordgrass patches that were adjacent to mudflat, but not in patches adjacent to non-host grasses, reflecting the lower rates of dispersal across inhospitable mudflats (Fig. 7.3). Ries and Fagan (2003) reported that egg case (oothecae) densities for a mantid, *Stagmomantis limbata*, were 3 times higher in two types of edge habitat than in interior habitats; bird predation on oothecae also was about 3 times higher in one type of edge habitat (and tended to be higher in the other), compared to interior habitats. This situation represents an ecological trap, in which an organism actively selects a poor habitat over superior one.

Roland and Kaupp (1995) found that transmission of the nuclear polyhedrosis virus was reduced along forest edges, prolonging outbreaks of the forest tent caterpillar, *Malacosoma disstria*. Similar results were found for understory insectivorous birds in tropical forests, suggesting that outbreaks of some insects could be more likely in fragments from which predators have disappeared (Şekercioğlu et al. 2002). Remnant patches of natural habitat also are highly vulnerable to an influx of non-indigenous species, from neighboring patches, which may compete with, or prey upon, indigenous species (Punntila et al. 1994). Ewers and Didham (2006) developed a statistical model to quantify the magnitude and extent of edge effects on four insect taxa. They found that the magnitude of edge effect and the extent of effect from the edge were not correlated but provided different information about edge effects.

The effects of edge density on the landscape can change during the course of population growth and decline. Radeloff et al. (2000) found that correlations between landscape patterns and the size of jack pine budworm, *Choristoneura pinus*, populations varied over time, with the proportion of jack pine, *Pinus banksiana*, and edge density (sum of perimeter length for land use classes per ha) being positively correlated up to the peak of the outbreak, but edge density negatively correlated during population decline. These results probably reflected the more suitable resources represented by pollen cones that were more abundant on edge trees and the greater abundance of avian predators and the primary wasp parasitoid, *Itoplectis conquisitor*, along edges.

Fragmentation does not affect all species equally, nor all negatively. Tschardtke (1992) reviewed studies that examined the responses of several insect species to differences in reed, *Phragmites australis*, quality in fragmented (agricultural) and unfragmented (nature reserve) wetlands. Reeds in small patches had thinner shoots but more leaves than did reeds in large patches. Two chloropid flies, *Lipara* spp., that depend on thin shoots survived only in the small patches or in the unmown edges of the large patches. However, the stem-boring



noctuid moth, *Archanara germinipuncta*, which depends on thick shoots, persisted only in the large patches. Shoot damage caused by this moth created necessary habitat for >20 other herbivores, saprovores and parasitoids. For example, the gall midge, *Lasioptera arundinis*, survived only in the side shoots induced by *A. germinipuncta* damage, making this midge equally dependent on large patches. Tschardt (1992) calculated that survival of local populations of *A. germinipuncta* requires at least 180,000 individuals or at least a 2 ha area.

Fragmentation of natural ecosystems typically is associated with homogenization of vegetation patterns. The widespread planting of commercial crops and suppression of natural disturbances have eliminated much of the diversity of vegetation patches that characterize natural landscapes. In a diverse landscape, outbreaks of particular demes most often would be confined to patches of susceptible vegetation. Agricultural and managed forest landscapes are more conducive to expansion and regionwide outbreaks of adapted species (e.g., Schowalter and Turchin 1993).

## B. Disturbances to Aquatic Ecosystems

Stream channelization and impoundment have reduced heterogeneity in channel morphology and flow characteristics. Channelization constrains channel morphology, removes obstacles to flow, and shortens stream length. These modifications eliminate habitats in overflow areas (such as wetlands and side channels) and in logs and other impediments, and speed drainage in the channeled sections. Impoundments replace a sequence of turbulent sections and pools created by logs and other obstacles (characterized by rocky substrates and high oxygen contents) with deep reservoirs (characterized by silty substrates and stratification of oxygen content and temperature). These changes in stream conditions eliminate the habitat of some species (such as those associated with high flow rate and oxygen concentrations) and increase habitat availability for others (such as species associated with lotic conditions and low oxygen concentrations).

The linear configuration of stream systems (i.e., the stream continuum concept, Vannote et al. 1980) makes them particularly vulnerable to disturbances that occur upstream. For example, heavy precipitation in the watershed is concentrated in the stream channel, scouring the channel and redistributing materials and organisms downstream. Fire or harvest of riparian vegetation exposes streams or wetlands to increased sunlight, raising temperatures and increasing primary production, altering habitat and resource conditions downstream, often for long time periods (Batzer et al. 2000a, Haggerty et al. 2004, Kiffney et al. 2003). Industrial effluents, runoff of agricultural materials (e.g., fertilizers), or accidental inputs of toxic materials (e.g., leachates from mine spoils and pesticides) affect habitat suitability downstream until sufficient dilution has occurred (S. Smith et al. 1983, Southwick et al. 1995). Eutrophication, resulting from addition of limiting nutrients, substantially alters the biological and chemical conditions of aquatic systems.

Lake Balaton (Europe's largest lake) in Hungary has experienced incremental eutrophication since the early 1960s, when lake chemistry was relatively uniform (Somlyódy and van Straten 1986). Since that time, phosphorus inputs from agricultural runoff and urban development have increased, starting at the west end where the Zala River enters the lake. The division of Lake Balaton into four relatively distinct basins, each of which drains distinct subwatersheds, has facilitated documentation of the progression of eutrophication from west to east (Somlyódy and van Straten 1986). Dévai and Moldován (1983) and PONYI et al. (1983) found that the abundance and species composition of chironomid larvae were correlated with this longitudinal gradient in water quality. The original species that characterized oligo-mesotrophic conditions have been replaced by species characterizing

eutrophic conditions in a west to east direction. Similarly, sedimentation resulting from erosion of croplands or clearcut forests, or from trampling of streambanks by livestock, alters substrate conditions and habitat suitability for organisms downstream.

Pringle (1997) reported that disturbances and anthropogenic modification of downstream areas (e.g., urbanization, channelization, impoundment, etc.) also affect conditions for organisms upstream. Degraded downstream areas may be more vulnerable to the establishment of exotic species that are tolerant of stream degradation. These species subsequently invade upstream habitats. Degradation of downstream areas may restrict the movement of upstream species within the watershed, thereby isolating headwater populations and limiting gene flow between watersheds. Finally, degradation of downstream zones may prevent the movement of anadromous or catadromous species.

Disturbances to adjacent terrestrial ecosystems can affect aquatic species. Davies and Nelson (1994) compared the responses of aquatic invertebrates to forest harvest within 10 m of streams, 10–30 m of streams, 30–50 m of streams or unharvested in Tasmania. Densities of aquatic invertebrates were measured at a site upstream of the treatment and at a second site immediately downstream from the treatment. Differences in mayfly (Ephemeroptera) and stonefly (Plecoptera) densities between the two sites were significantly, positively correlated with the width of the riparian forest buffer. Overall, mayfly density declined by 62% and stonefly density by 34% at sites with < 30 m buffer, demonstrating the importance of riparian forest buffers to these aquatic detritivores. In a similar study in western Canada, Kiffney et al. (2003) compared periphyton and chironomid midge grazer abundances in streams with no riparian buffer (clearcut to stream edge), 10 m or 30 m buffer, and uncut control. Periphyton mass and chironomid abundance generally increased with increasing solar exposure, i.e., with decreasing buffer width, demonstrating a different response to riparian buffer width by grazing insects.

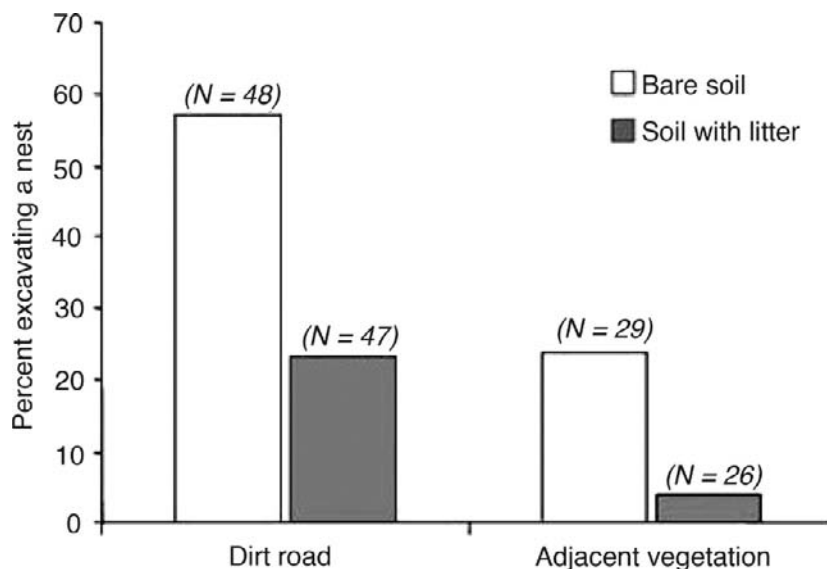
### C. Anthropogenic Transport Across Barriers

Human transportation of exotic species across natural barriers to their dispersal has dramatically altered the structure and function of natural ecosystems across the globe (Samways 1995, A. Suarez et al. 1998, Wallner 1996). Examples of this include the devastation of island vegetation by pigs and goats that were introduced intentionally by explorers; destruction of grasslands across the globe by domesticated, often introduced livestock; disruption of aquatic communities by introduced species (e.g., water hyacinth and zebra mussel in North America); disruption of grassland and forest communities by introduced plants (e.g., spotted knapweed in North America), mammals (e.g., rabbits in Australia), reptiles and amphibians (brown tree snake in Oceania, African clawed frog in North America), insects (e.g., gypsy moth in North America, the European wood wasp, *Sirex noctulio*, in Australia) and pathogens (e.g., chestnut blight and white pine blister rust in North America, Dutch elm disease in North America and Europe, pinewood nematode in Japan). Exotic species, especially of insects, can be found in virtually all “natural” ecosystems on all continents. Many herbivorous insects and mites have arrived on agricultural or forestry products and become plant pests in agroecosystems or forests. Some herbivorous and predaceous arthropods have been introduced intentionally for the biological control of exotic weeds or plant pests (e.g., Croft 1990, Kogan 1998, McEvoy et al. 1991). Despite evaluation efforts, these biological control agents, especially arthropod predators, compete with native species and have the potential to colonize native hosts which are related to the exotic host and develop new biotypes (Louda et al. 2003). Indigenous herbivore species also can colonize exotic hosts and develop new biotypes (D. Strong et

al. 1984), with unknown consequences for long term population dynamics and community structure. Samways et al. (1996) found that different invertebrate assemblages were found on exotic vegetation, compared to indigenous vegetation, in South Africa.

Urban areas represent increasingly large and interconnected patches on regional landscapes and are particularly important ports for the spread of exotic species into surrounding ecosystems. Urban centers are the origin or destination for commercial transport of a wide variety of materials, including forest and agricultural products, and often have highly modified climatic conditions, e.g., heat islands (Arnfield 2003). These areas are characterized by the presence of a wide variety of exotic species, especially ornamental plants and their associated exotic insects and pathogens. Exotic or native ornamental species typically are stressed by soil compaction, air and water pollutants, and hot, dry conditions. (Arnfield 2003). Arriving exotics often have little difficulty finding suitable hosts and becoming established in urban centers and subsequently spreading into surrounding ecosystems.

Road systems that connect urban centers and penetrate natural ecosystems represent unique ecosystems that can interrupt population movement or provide corridors that facilitate the spread of native or exotic species (Lugo and Gucinski 2000, Vasconcelos et al. 2006). Roadsides typically are highly disturbed by road maintenance, other human activities, and air pollution from vehicles, and provide suitable habitat for a variety of species (Figure 7.11). Gypsy moth is particularly capable of spreading via human transportation (of pupae or egg masses attached to vehicles, outdoor equipment or commercial products) between urban centers. Stiles and Jones (1998) demonstrated that population distribution of the red imported fire ant, *Solenopsis invicta*, was significantly affected by width and disturbance frequency of road and powerline corridors through forests in the southeastern U.S. Mound densities were significantly highest along dirt roads not covered by forest canopy and lowest along roads covered by forest canopy. Powerline and graveled or paved roads not covered by forest canopy supported intermediate densities of mounds.



**FIG. 7.11** Percentage of *Atta laevigata* queens excavating nests in bare soil or soil with litter in roadsides or adjacent cerrado vegetation in Brazil. From Vasconcelos et al. (2006) with permission from John Wiley & Sons.

These trends suggest that canopy openings of intermediate width and high disturbance frequency are most conducive to fire ant colonization.

## V. MODELS OF SPATIAL DYNAMICS

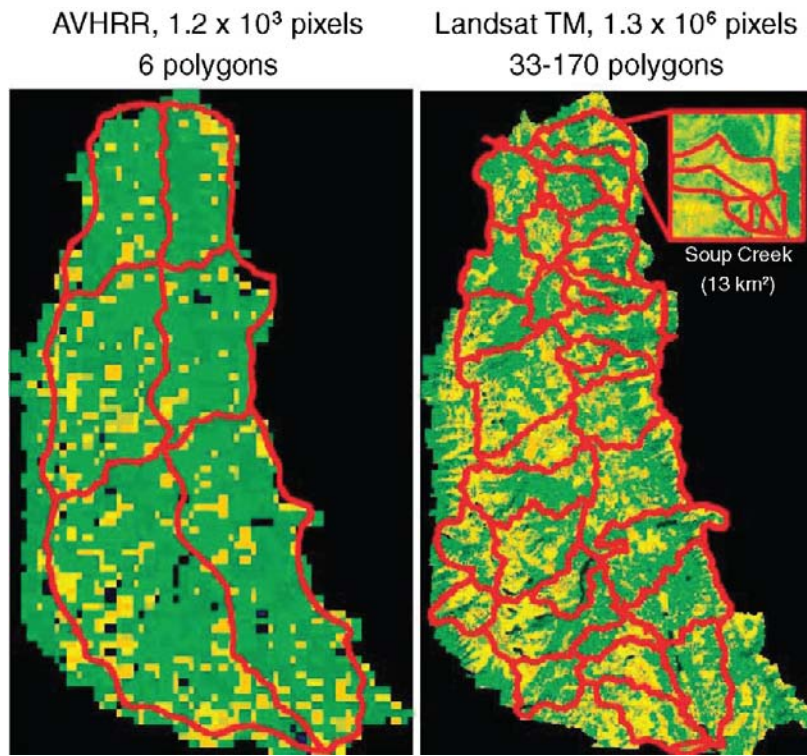
The most significant advance in population dynamics research in recent years has been the development of spatially explicit models of population dynamics. A number of approaches have been used to model spatial dynamics. As with temporal dynamics, spatial dynamics can be modeled using deterministic, stochastic or chaotic functions (Hassell et al. 1991, Matis et al. 1994, Sherratt and Jepson 1993). Different spatial dynamics result from using these different types of functions.

The earliest attempts to model spatial dynamics either applied diffusion models to describe insect dispersal and population spread from population centers (Rudd and Gandour 1985, Skellam 1951, Turchin 1998) or modeled population dynamics independently among individual landscape patches, based on local conditions within each patch, then linked the patches by dispersal processes (e.g., W. Clark 1979). Diffusion models assume that the environment is homogeneous and that individuals disperse independently and with equal probability in any direction. This approach is useful for modeling the spatial dynamics of insects in stored grain or relatively homogenous crop systems, but is less useful in most natural landscapes where patchiness interrupts diffusion.

Advances in spatial modeling have been facilitated by development of powerful computers that can store and manipulate large data sets. Concurrent development of geographic positioning systems (GPS), geographic information systems (GIS), and geostatistical software has been key to describing insect movement (Turchin 1998) and population epidemiology (Liebhold et al. 1993) across landscapes.

A GIS is an integrated set of programs that facilitate the collection, storage, manipulation and analysis of geographically referenced data, such as topography, vegetation type and density, and insect population densities. Data for a particular set of coordinates can be represented as a value for a cell, and each cell in the matrix is given a value (Fig. 7.12). This method is called the **Raster method**. A second method, that requires less storage space, is the **vector method**, in which only data representing the vertices of polygons that contain data must be stored (Fig. 7.12). Various matrices representing different map layers can be superimposed to analyze interactions. For example, a map layer representing insect population distribution can be superimposed on map layers representing the distribution of host plants, predator abundances, climatic conditions, disturbances, or topography to evaluate the effects of patchiness or gradients in these factors on the spatial dynamics of the insect population.

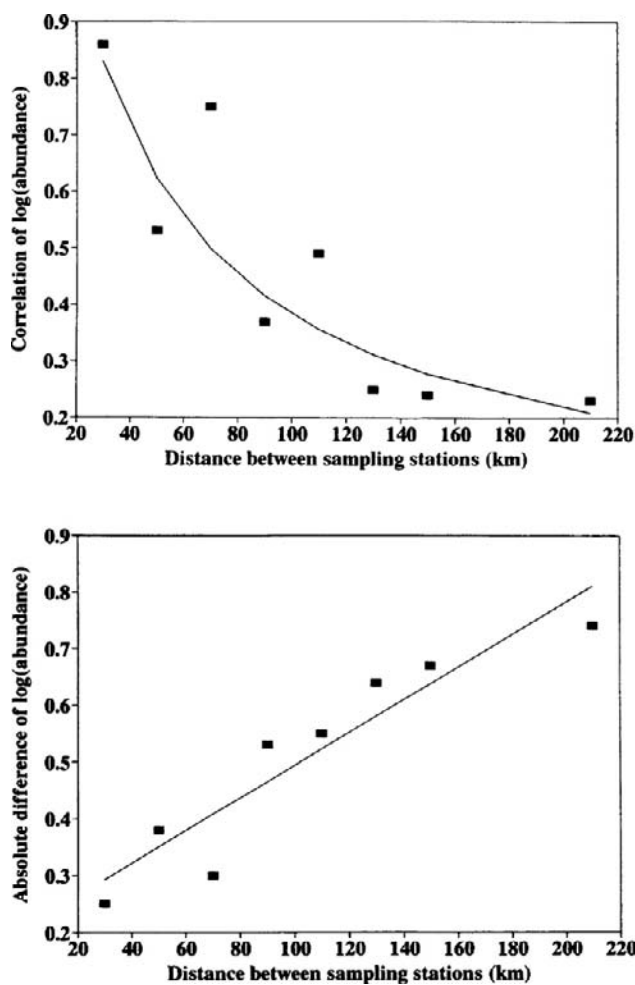
Geostatistics are a means of interpolating the most probable population densities between sample points, in order to improve the representation of spatial distribution over landscapes. Early attempts to characterize spatial patterns were based on modifications of  $s^2/x$ , Taylor's Power Law, Lloyd's Patchiness Index, and Iwao's patchiness regression coefficients (Liebhold et al. 1993). These indices focus on frequency distributions of samples, and are useful for identifying dispersion patterns (see Chapter 5), but ignore the spatial locations of samples. Modeling spatial dynamics across landscapes requires information on the location of sampling points, as well as population density data. The locations of population aggregations affect densities in adjacent cells (Coulson et al. 1996, Liebhold and Elkinton 1989). Development of geographic positioning systems (GPS) has facilitated incorporation of precise sample locations in GIS databases.



**FIG. 7.12** Examples of geostatistical representation. The Seeley-Swan watershed in Montana, U.S., is depicted with  $1\text{km}^2$  raster cells on the left, by  $30 \times 30 \text{ m}$  raster cells on the right, and with vector polygons defined from topographic analysis in the inset. The more heterogeneous the landscape, the greater the number of cells required to provide an accurate assessment of spatial variation. From R. Waring and Running (1998).

An underlying assumption of geostatistics is that the degree of similarity between sample points is correlated with their proximity (Fig. 7.13) (Coulson et al. 1996, Gilbert and Grégoire 2003, Grilli and Gorla 1997, Liebhold et al. 1993, M. Smith et al. 2004). Population structure in a given cell is influenced by the population structures in neighboring cells more than it is by distant cells. An autocorrelation matrix can be developed from data for different distance classes, i.e.,  $x$  and  $y$  coordinates differing by a given distance (Liebhold and Elkinton 1989). This spatial autocorrelation can be used to interpolate values for unsampled locations by taking a weighted linear average of available samples, a technique known as **kriging** (Gilbert and Grégoire 2003, Gribko et al. 1995, Grilli and Gorla 1997, Hohn et al. 1993, Liebhold et al. 1993). Kriging represents an advance over traditional methods of interpolation in several ways, but its most important provision is the incorporation of several forms of information simultaneously. The joint spatial dependence of population density and factors such as climate, soil conditions, vegetation, etc. can be integrated to provide more accurate estimates than would be possible with any single variable.

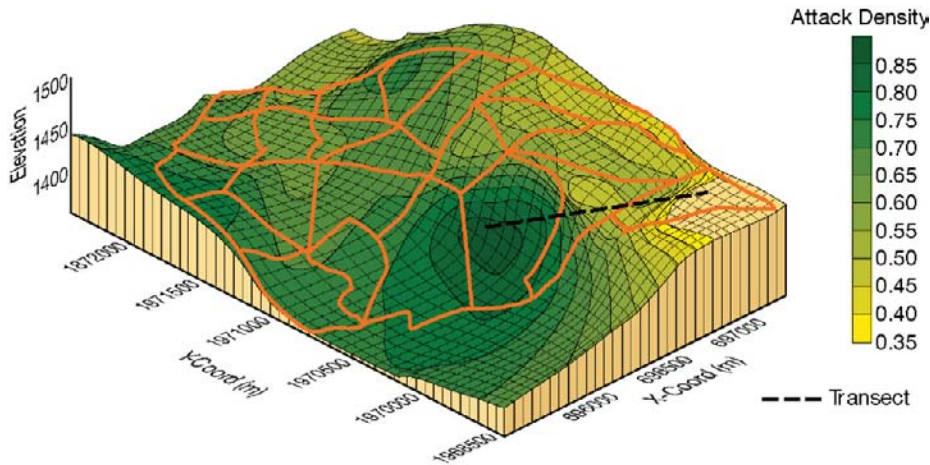
Gilbert and Grégoire (2003) used these methods to evaluate the factors affecting the spatial structure of the European bark beetle, *Dendroctonus micans*, in a French spruce forest (Fig. 7.14). They demonstrated that the *D. micans* population had a strong spatial



**FIG. 7.13** Relationships between the temporal correlation of *Delphacodes kuscheli* density and the distance between sampling stations (top) and between the mean absolute difference between densities of pairs of sampling stations and the distance between sampling stations (bottom) in Argentina. From Grilli and Gorla (1997) with permission from CAB International, Wallingford, U. K.

structure, significantly related to tree density, average slope within a 250 m radius, and the abundance of a specialist predator, *Rhizophagus grandis*, released within a 300 m radius more than 6 yrs previously. D. Williams and Liebhold (1995) used these techniques to predict the spatial distribution of insect population densities under potential future climates (Fig. 7.10).

Modeling of spatial dynamics in stream networks or montane topography with branched topology presents special challenges. In such networks, the distance between two points may not be represented adequately by the Euclidean distance, because of limitations to movement of aquatic organisms across land. Rather, the shortest distance from the perspective of aquatic organisms is along the stream channel (Fig. 7.15A). Ganio et al. (2005) described the use of an empirical variogram, based on shortest distances along the network pathway between sample points, to evaluate spatial patterns and differences



**FIG. 7.14** Spatial structure of proportion of trees attacked by *Dendroctonus micans*, based on two-dimensional omni-directional kriging, in a 600 ha spruce stand in France. From Gilbert and Grégoire (2003) with permission from John Wiley & Sons.

in spatial structure along stream networks in western Oregon, U.S. (Fig. 7.15B). Such new tools will contribute to modeling of spatial structure in aquatic populations.

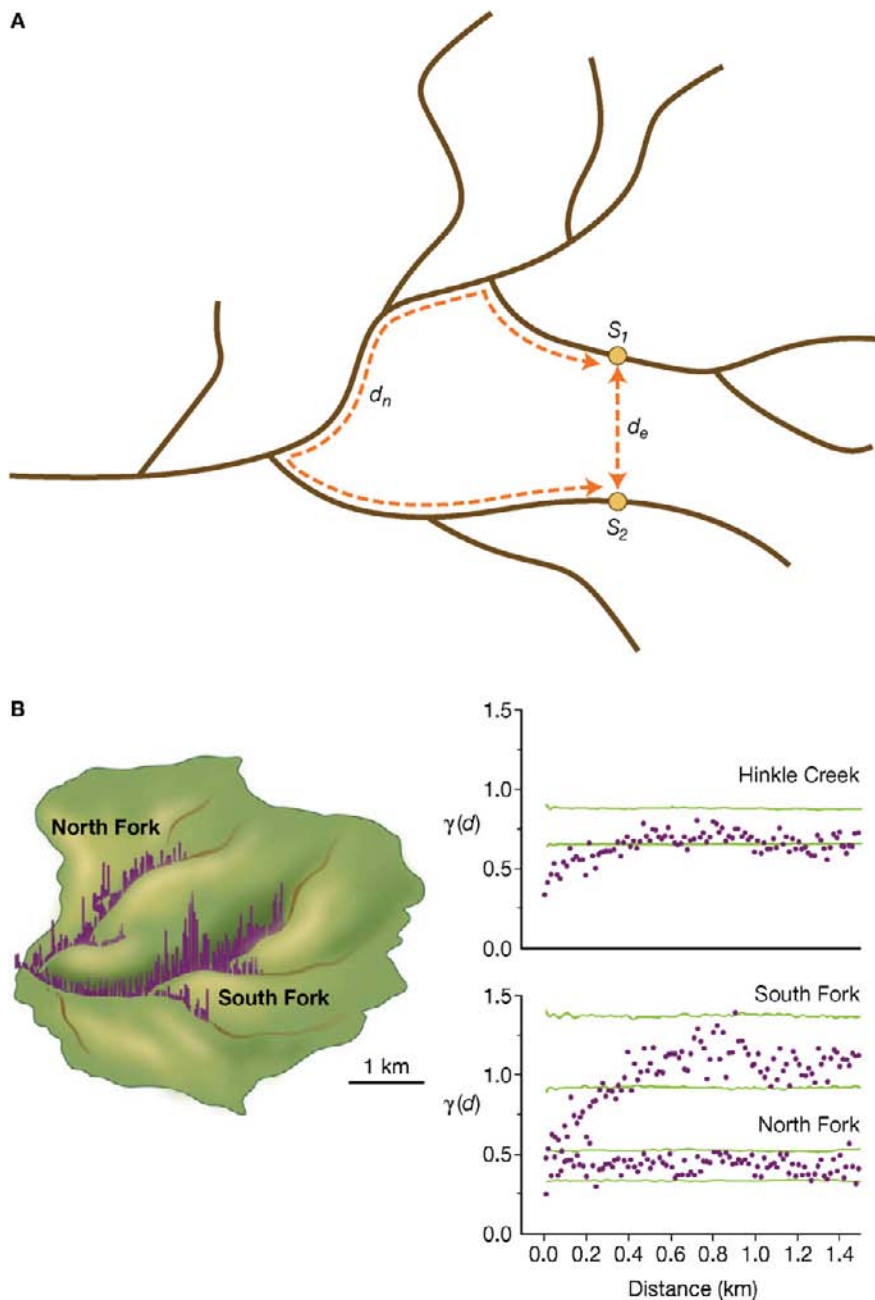
## VI. SUMMARY

Factors affecting the geographic distributions of populations have intrigued ecologists for at least the past two centuries. Distributions can be described at different geographic scales. Six distinctive floral and faunal associations (biogeographic realms) can be identified, conforming roughly to continental boundaries, but also reflecting the history of continental movement (plate tectonics). Topography also creates gradients in environmental conditions on mountains and temperature stratification with depth in aquatic ecosystems.

The distribution of species among islands intrigued early ecologists. The ability of populations to colonize oceanic islands was found to reflect the dispersal capacity of the species, the size of the island and its distance from the population source. Although controversial, principles of island biogeography have been applied to colonization of terrestrial habitat islands, e.g., mountaintops and patches of unique habitat in otherwise inhospitable landscapes.

At more local scales, the spatial distribution of populations changes with population size. Growing populations expand over a larger area as individuals move from high-density patches to the fringe of the population. Rapidly expanding populations generate large numbers of dispersing individuals that maximize the colonization of new patches. Under favorable conditions, these satellite demes expand and coalesce with the main population, affecting ecosystem processes over large areas. Declining populations shrink into isolated refuges that maintain distinct demes of a metapopulation. The extent of dispersal among these demes determines genetic heterogeneity and the ability to recolonize patches following local extinctions.

All populations are vulnerable to local extinctions due to changing environmental conditions and disturbances. Populations survive to the extent that their dispersal strategies



**FIG. 7.15** A) Distance between points  $S_1$  and  $S_2$  in a network can be measured either as Euclidean distance ( $D_e$ ) or as distance along the network pathway ( $D_n$ ); B) spatial distribution and empirical variograms of coastal cutthroat trout counts in Hinkle Creek in western Oregon. Variograms show semivariance as a function of network distance ( $D_n$ ) with 2.5<sup>th</sup> and 97.5<sup>th</sup> percentiles from 5000 permutations (red lines) for the entire watershed and for the North and South forks separately. From Ganio et al. (2005) with permission from the Ecological Society of America.



facilitate recolonization and population movement over landscapes. Anthropogenic activities alter spatial distribution in several ways. Climate changes affect the geographic distribution of suitable habitats. However, the most serious anthropogenic effects on spatial patterns are habitat fragmentation, alteration and pollution of aquatic ecosystems, and redistribution (intentionally or unintentionally) of various species. Fragmentation increases the isolation of demes and places many species at risk of extinction. At the same time, predators and parasites appear to be most vulnerable to fragmentation and habitat disturbances, often increasing opportunities for population growth by prey species. Humans also are responsible for the introduction of a large and growing number of plant and animal species to new regions, as a result of transportation of commercial species and forest and agricultural products. Urban areas represent centers of commercial introductions and provide opportunities for exotic, ornamental and associated species to become established and to move into surrounding ecosystems. These species affect various ecosystem properties, often dramatically altering vegetation structure and competing with, or preying on, native species.

The modeling of spatial distribution patterns has been facilitated by the recent development of geographic information systems (GIS) and geostatistical techniques. Early models represented population expansion as a simple diffusion process. Application of GIS techniques to the patch dynamics of metapopulations permits integration of data on population dynamics with data on other spatially varying factors across landscapes. Geostatistical techniques, such as kriging, permit interpolation of density data between sampling stations to improve mapping and projection of population distributions. These techniques are improving our ability to evaluate population contributions to ecosystem properties across landscapes.



# COMMUNITY ECOLOGY

SPECIES CO-OCCURRING AT A SITE WILL INTERACT TO VARIOUS degrees, both directly and indirectly, in ways that have intrigued ecologists since earliest times. These interactions regulate population dynamics, hence community structure, and also control rates of energy and matter fluxes, hence ecosystem function. Some organisms engage in close, direct interactions, as consumers and their hosts, whereas others interact more loosely and indirectly. For example, predation on mimics depends on the presence of their models, and herbivores are affected by their host's chemical responses to other herbivores. Direct interactions, i.e., competition, predation and symbioses, have been the focus of research on factors that control community structure and dynamics, but indirect interactions also control community organization. Species interactions are the focus of [Chapter 8](#).

A community is composed of the plant, animal and microbial species occupying a site. Some of these organisms are integral and characteristic components of the community and help define the community type, whereas others occur by chance as a result of movement across a landscape or through a watershed. Particular combinations of species distinguish desert, grassland or forest communities. Different assemblages of species are found in turbulent stream vs. lake, or eutrophic vs. oligotrophic systems. The number of species and their relative abundances define species diversity, a community attribute that is the focus of a number of ecological issues. [Chapter 9](#) addresses the various approaches that can be taken to describe community structure and the range of factors which determine geographic patterns of community structure.

Community structure and interactions change through time, as populations respond differently to changing environmental conditions, especially to disturbances and changes in resource availability and predation. Just as population dynamics reflect the net effects of individual natality, mortality and dispersal interacting with the environment, community dynamics reflect the net effects of species population dynamics interacting with the environment. Severe

---

disturbance or environmental changes can lead to drastic changes in community structure. Recent studies are clarifying changes in prehistoric community structure and interactions. Changes in community structure through time are the subject of a vast literature, which is summarized in Chapter 10.

Community structure largely determines the biotic environment that affects individuals (Section I) and populations (Section II). The community also modifies the abiotic conditions of a site. Vegetation cover reduces albedo (reflectance of solar energy), modifies temperature and humidity within the boundary layer, reduces soil erosion, and alters energy and biogeochemical fluxes, when compared to non-vegetated sites. Species interactions, including those involving insects, modify vegetation cover and affect these processes, as discussed in Section IV. Different community structures affect these processes in different ways.

# Species Interactions

## I. Classes of Interactions

- A. Competition
- B. Predation
- C. Symbiosis

## II. Factors Affecting Interactions

- A. Abiotic Conditions
- B. Resource Availability and Distribution
- C. Indirect Effects of Other Species

## III. Consequences of Interactions

- A. Population Regulation
- B. Community Regulation

## IV. Summary

### Species interactions speed the spread of disease

The rapid spread of West Nile Virus (WNV) across the U.S. following its introduction in 1999 reflected complex interactions among bird hosts and the mosquito vectors of the virus. West Nile virus originated in central Africa, perhaps 1000 years ago, as a zoonotic disease of birds, but was not recognized until 1937 when a human case was diagnosed in the West Nile District of Uganda. It appeared in New York City in 1999, perhaps through introduction of an infected bird or mosquito vector, and caused 62 human cases of encephalitis (7 deaths), concurrent with extensive mortality of crows, *Corvus* spp., and exotic birds at a zoological park (Lanciotti et al. 1999). By 2001 the disease was epidemic in New York and Florida and increasing in incidence in other East and Gulf Coast states. In 2002, 4156 human cases and 284 deaths were recorded, primarily in the Great Lakes states and Louisiana. The following year the disease caused 264 deaths among nearly 10,000 human cases in the Midwest. The disease reached epidemic proportions on the West Coast in 2004 and the Pacific Northwest in 2006 before declining in incidence among humans through 2009.

Infection of horses and humans typically followed the spread of infected birds, the primary (reservoir) hosts of the virus. Some avian species suffered 100% mortality of infected individuals, whereas others showed virtually none (LaDeau et al. 2008). Of 20 species of potential avian hosts across the U.S., seven species, in four families, showed significant declines in abundance as a result of WNV, with American crows, *Corvus brachyrhynchos*, declining by 45% following WNV introduction (LaDeau et al. 2007). Only two of the seven species had recovered to pre-WNV abundances by 2005.

The virus is vectored by mosquitoes. Mosquito species varied in their ability to transmit the virus. Among 25 mosquito species known to carry WNV in nature, *Aedes albopictus* (Asian tiger mosquito), *Culex pipiens*, *Culex quinquefasciatus*, *Culex restuans*, *Culex salinarius*, *Culex tarsalis* and *Ochlerotatus japonicus* were highly efficient vectors, whereas *Ochlerotatus sierrensis*,

(cont.)

*O. taeniorhynchus* and *Psorophora ferox* had little or no ability to transmit the virus (Turell et al. 2005). Furthermore, *Culex* species feeding primarily on birds were the primary enzootic vectors, but opportunistic species such *A. albopictus* and *O. japonicus* were important bridge vectors that transmitted the virus from birds to mammals (Turell et al. 2005).

B. Allan et al. (2009) tested hypotheses that WNV transmission is related to bird species diversity, to mosquito vector abundance, or to human population density. They found that the prevalence of WNV infection in mosquitoes and humans increased with decreasing bird species diversity and increasing proportion of primary reservoir hosts. Thus, conservation of avian diversity should reduce transmission by mosquitoes by distributing blood meals among more bird species, many of which would be non-reservoir hosts.

## INTRODUCTION

JUST AS INDIVIDUALS INTERACT IN WAYS THAT AFFECT POPULATION structure and dynamics, species populations in a community interact in ways that affect community structure and dynamics. Species interactions vary considerably in their form, strength and effect, and create quite complex networks among species. One species can influence the behavior or abundance of another species directly, e.g., a predator feeding on its prey, or indirectly through effects on other interacting species, e.g., herbivore-induced production of plant chemicals that attract predators and deter feeding by herbivores which arrive later. The web of interactions, direct and indirect, and having positive or negative feedback, determines the structure and dynamics of the community (see Chapters 9 and 10) and controls rates of energy and matter fluxes through ecosystems (see Chapter 11).

Insects have provided key examples of species interactions. Complex and elaborate interactions between plants and associated insect herbivores and pollinators, and also between parasites and their hosts, including paleontological evidence of their evolutionary development (Boucot and Poinar 2010, Labandeira 1998, 2002, Poinar and Poinar 2004b, 2005), have been among the most widely studied. Our understanding of plant–herbivore, predator–prey and various symbiotic interactions is derived largely from models involving insects. This chapter describes the major classes of interactions, factors that affect these interactions, and consequences of these interactions for community organization.

## I. CLASSES OF INTERACTIONS

Species interact with other species in various ways and with varying degrees of intimacy (interaction strength). Individuals compete with, prey on, or are prey for, various associated species, and may be involved in stronger interactions with particular species (i.e., symbiosis). Categories of interactions generally have been distinguished on the basis of their direct effects, i.e., positive, neutral or negative effects on growth or mortality of each species. However, the complexity of indirect effects on interacting pairs of species by other associated species has become widely recognized (e.g., Clay et al. 1993, M.L. Johnson et al. 2006, Karban and Baldwin 1997, Kessler et al. 2006, Ohgushi 2005, 2008, Poveda et al. 2007, Van Zandt and Agrawal 2004). Indirect interactions often may affect communities as substantially as more obvious direct effects. Furthermore, interactions may have multiple effects on the species involved, depending on the abundance and condition of the partners. This requires consideration of the net effects of an interaction in order to understand its origin and consequences (Økland et al. 2009).

## A. Competition

Competition is the struggle for use of shared, limiting resources (Fig. 8.1). Resources can be limiting at various amounts and for various reasons. Any resource can be an object of interspecific competition, e.g., food resources, basking or oviposition sites, etc. Water or nutrient resources may be largely unavailable and support only small populations or a few species in certain habitats (e.g., desert and oligotrophic lakes), but be abundant and support larger populations or more species in other habitats (e.g., rain forest and eutrophic lakes). Newly available resources may be relatively unlimited until sufficient colonization has occurred to reduce per capita availability.

Although competition for limited resources has been a major foundation concept for evolutionary theory (Malthus 1789, Darwin 1859), its role in natural communities has



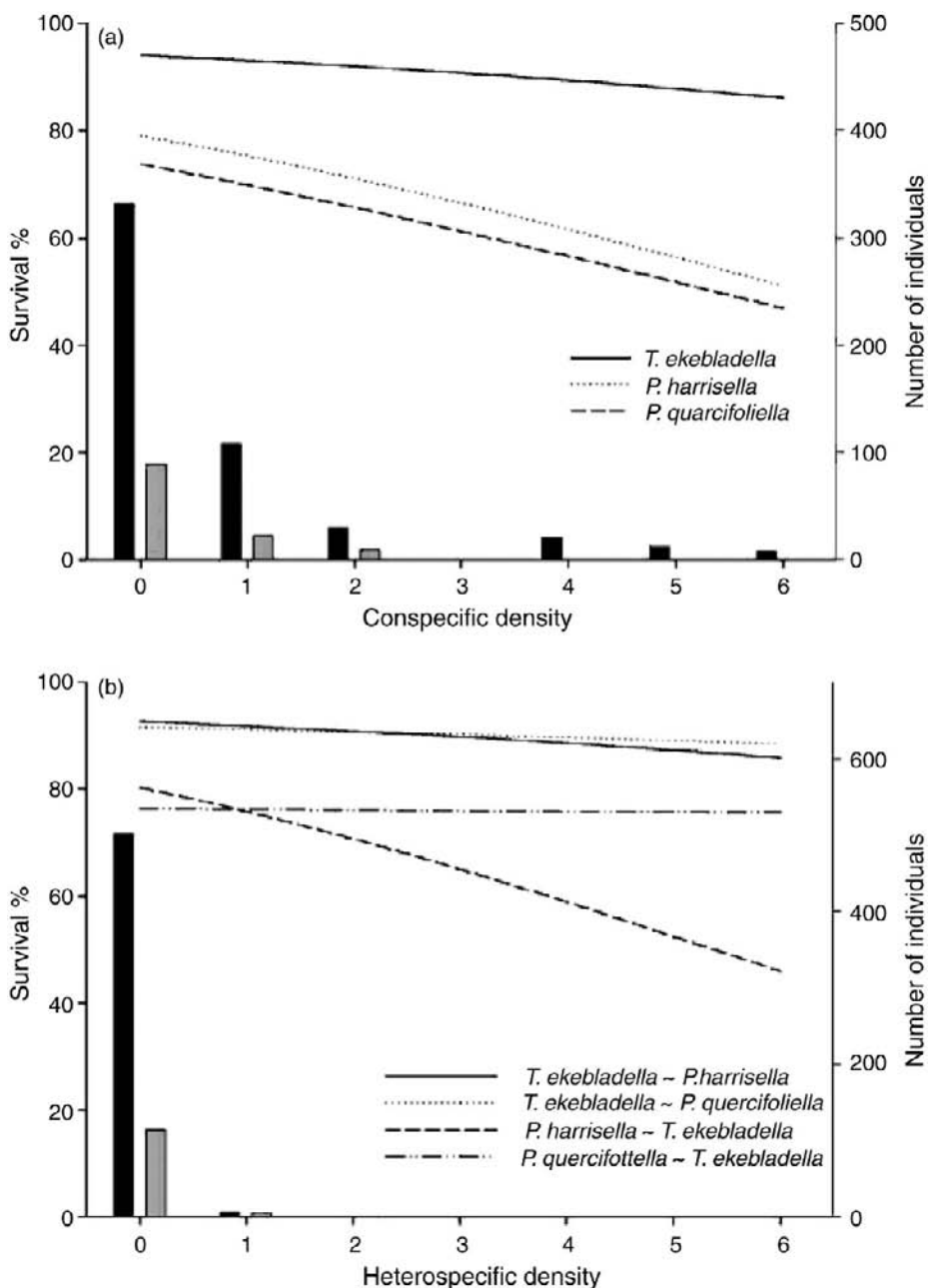
**FIG. 8.1** Competition: evidence of interference between southern pine beetle, *Dendroctonus frontalis*, larvae (small mines) and co-occurring cerambycid, *Monochamus titillator*, larvae (larger mines) preserved in bark from a dead pine tree. The larger cerambycid larvae often remove phloem resources in advance of bark beetle larvae, consume bark beetle larvae in their path, or both.

been controversial (e.g., Connell 1983, Lawton 1982, Lawton and Strong 1981, Schoener 1982, D. Strong et al. 1984). Denno et al. (1995) and Price (1997) attributed the controversy to three major criticisms that arose during the 1980s. First, the early studies were primarily laboratory experiments or field observations. Few experimental field studies were conducted prior to the late 1970s (Istock 1973). Second, Hairston et al. (1960) argued that food must rarely be limiting to herbivores, because so little plant material is consumed under normal circumstances (see also Chapter 3), leading to experimental focus on effects of predators, parasites and pathogens on herbivore populations during the late 1970s and early 1980s. Third, many species that were assumed to compete for the same resource(s) co-occur and appear not to be resource limited. In addition, many communities apparently were unsaturated, i.e., many niches were vacant (e.g., Kozár 1992b, D. Strong et al. 1984). Controversy stimulated experimental approaches to studying competition. Some (but not all) experiments in which one competitor was removed have demonstrated increased abundance or resource use by the remaining competitor(s), providing evidence for competition (T. Davis and Hofstetter 2009, Denno et al. 1995, Istock 1973, 1977, Pianka 1981, Tack et al. 2009). However, many factors affect interspecific competition (Colegrave 1997). Denno et al. (1995), S. Moser and Obrycki (2009), Pianka (1981) and Tack et al. (2009) suggested that competition may operate over a gradient of intensities, depending on the relative densities of the competing species (Fig. 8.2) and degree of niche partitioning (see below).

Denno et al. (1995) reviewed studies involving 193 pairs of phytophagous insect species. They found that 76% of these interactions demonstrated competition, whereas only 18% indicated no competition, although they acknowledged that the published studies might be biased in favor of species that were expected to compete. The strength and frequency of competitive interactions varied considerably. Generally, interspecific competition was more prevalent, frequent and symmetric among haustellate (sap-sucking) species than among mandibulate (chewing) species, or between sap-sucking and chewing species. Competition was more prevalent among species feeding internally, e.g., miners and seed-, stem-, and wood-borers (Fig. 8.1), than among species feeding externally. Competition was observed least often among free-living, chewing species, i.e., those selected for earlier studies that challenged the importance of competition.

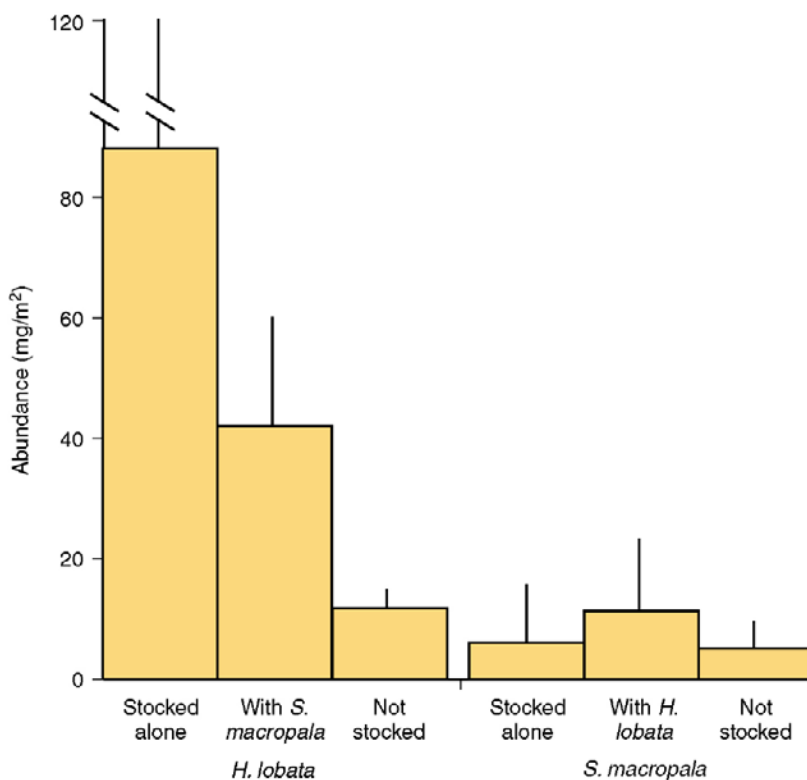
Most competitive interactions (84%) were asymmetric, i.e., one species was a superior competitor and suppressed the other (Denno et al. 1995). Root feeders were consistently out-competed by folivores, although such competitive interactions can be mediated by host plant factors (see Chapter 3, and below under Indirect Effects of Other Species). Istock (1973) demonstrated experimentally that competition between two water boatmen species was asymmetrical (Fig. 8.3). The population size of *Hesperocorixa lobata* was reduced significantly when *Sigara macropala* was present, but population size of *S. macropala* was not affected significantly by the presence of *H. lobata*.

Competition generally is assumed to have only negative effects on both (all) competing species (but see below under Indirect Effects of Other Species). As discussed in Chapter 6, competition among individuals in a population represents a major negative feedback mechanism that regulates population size. Similarly, competition among species regulates the total abundance of multiple species populations (Siepielski et al. 2010). As the total density of all individuals of competing species increases, each individual has access to a decreasing per capita share of the resource(s). If the competition is asymmetric, the superior species may competitively suppress other species, leading over sufficient time to **competitive exclusion** (Denno et al. 1995, Park 1948, D. Strong et al. 1984). However, Denno



**FIG. 8.2** Density-dependence of interspecific competitive effects among leaf miners on the same leaf in laboratory experiments (lines) and the frequency of co-occurrence in the field (histograms) on *Quercus robur* in Finland. Effect of interspecific larval density on survival of the focal species of competing pairs is shown as a function of the density on the same leaf of the second species in each pair. The histogram shows the number of individuals in the field that encounter competing larvae of a second species on the same leaf. Black bars show numbers of *Tischeria ekebladella* and gray bars numbers of *Phyllonorycter* in each category. From Tack et al. (2009) with permission from the authors and John Wiley & Sons.





**FIG. 8.3** Results of competition between two water boatmen species, *Hesperocorixa lobata* and *Sigara macropala*, in 1.46 m<sup>2</sup> enclosures in a 1.2 ha pond. Enclosures were stocked in June with adult *H. lobata* and/or *S. macropala* and final abundance measured after 2 mos. Water boatmen in unstocked enclosures provided a measure of colonization. Vertical bars represent 1 S.D. N=4–8. Data from Istock (1973).

et al. (1995) found evidence of competitive exclusion in less than 10% of the interactions they reviewed. Competitive exclusion may be prevented normally by factors that limit complete pre-emption of resources by any species. For example, predation often limits population growth of the superior species and reduces its ability to exclude other species (R. Paine 1966, 1969a, b).

Interspecific competition takes two general forms and has two possible outcomes. **Exploitation competition** occurs when all individuals of the competing species have equal access to the resource. Species that can find or exploit a resource more quickly, develop or reproduce more rapidly, or increase resource use efficiency are favored under such circumstances. **Interference competition** involves pre-emptive use, and often defense, of a resource. This allows more aggressive species to increase their access to, and share of, the resource, to the detriment of other species.

Many species avoid resources that have been exploited previously, thereby losing access to them. Parasitic wasps frequently avoid hosts that are already parasitized by other wasps. Van Baaren et al. (2009) studied the host attacking behavior of three *Aphidius* species that share the same aphid host, *Sitobion avenae*. Females of *Aphidius rhopalosiphi* and *Aphidius avenae* each discriminated between unparasitized hosts and hosts that

had been parasitized by the other species, but recognition of parasitized hosts occurred only after ovipositor insertion, indicating perception of an internal marker. Females of *A. rhopalosiphi* and *Aphidius ervi* also discriminated between unparasitized hosts and hosts parasitized by the other species, but recognition in this case occurred through antennal perception, prior to ovipositor insertion, indicating the detection of an external marker.

Foraging ants often attack other predators and pre-empt prey resources. Halaj et al. (1997) reported that exclusion of foraging ants in young conifer plantations increased the abundances of arboreal spiders by greater than 1.5-fold. Foragers of the harvester ant, *Pogonomyrmex barbatus*, often encounter foragers from neighboring colonies, but relatively few encounters (about 10%) involved fighting, and fewer (21% of fights) resulted in the death of any of the combatants (Gordon and Kulig 1996). Nevertheless, colonies were spaced at distances that indicated competition. Gordon and Kulig (1996) suggested that exploitative competition among ants foraging for resources in the same area may be more costly than is interference competition.

Because competition can be expensive, in terms of lost resources, time, and/or energy spent in defending resources (see Chapter 4), evolution should favor strategies that reduce competition. Hence, competing species might be expected to minimize their use of the contested portion of a resource and maximize use of non-contested portions. This behavior results in the partitioning of resource use, a strategy referred to as **niche partitioning**. Over evolutionary time, sufficiently consistent partitioning might become fixed as part of the species' adaptive strategies, and species would no longer respond to changes in the abundance of former competitor(s). In such cases, competition is not evident, although niche partitioning may provide evidence of competition in the past (Connell 1980). However, niche partitioning among congeners may reflect speciation and divergence into unexploited niches, rather than interspecific competition (Fox and Morrow 1981). Niche partitioning is observed commonly in natural communities. Species competing for habitat, food resources, or oviposition sites tend to partition thermal gradients, time of day, host species, host size classes, feeding mode, etc. Several examples are noteworthy.

Granivorous ants and rodents frequently partition available seed resources, with the ants specializing on smaller seeds and the rodents on larger seeds when the two compete. J. Brown et al. (1979) reported that both ants and rodents increased in abundance in the short term when the other was removed experimentally. However, Davidson et al. (1984) found that ant populations in rodent-removal plots declined gradually but significantly after about 2 yrs. Rodent populations did not decline over time in ant-removal plots. These results reflected a gradual displacement of small-seeded plants (on which ants specialize) by large-seeded plants (on which rodents specialize) in the absence of rodents. Ant removal led to higher densities of small-seeded species, but these species could not displace the large-seeded plants.

Predators frequently partition resources on the basis of prey size. Predators must balance the higher resource gain against the greater energy expenditure for the capture and processing of larger prey (e.g., Ernsting and van der Werf 1988). Generally, predators should select the largest prey that can be handled efficiently (Holling 1965, Mark and Olesen 1996), but prey size preference also depends on hunger level and prey abundance (Ernsting and van der Werf 1988) (see below).

Most bark beetle (Scolytinae) species can colonize extensive portions of dead or dying trees when other species are absent. However, given the relative scarcity of dead or dying trees and the narrow window of opportunity for colonization (the first year after tree death), these insects are adapted to finding such trees rapidly (see Chapter 3), and typically several

species co-occur in colonized trees (T. Davis and Hofstetter 2009). Under these circumstances, subcortical resources are partitioned on the basis of beetle size, because each species shows highest survival in phloem that is thick enough to accommodate growing larvae, and because larger species are capable of repulsing smaller species (e.g., Flamm et al. 1993). Therefore, the largest species typically occur around the base of the tree, and progressively smaller species occupy successively higher portions of the bole, with the smallest species colonizing the upper bole and branches. However, other competitors, such as wood-boring cerambycids and buprestids often excavate through bark beetle mines, feeding on bark beetle larvae and reducing survival (Fig. 8.1) (Coulson et al. 1980, Dodds et al. 2001).

Many species partition resource use in time. Partitioning can be by time of day, e.g., nocturnal vs. diurnal Lepidoptera (Schultz 1983) and nocturnal bat and amphibian vs. diurnal bird and lizard predators (Reagan et al. 1996), or by season, e.g., asynchronous occurrence of 12 species of water boatmen (Hemiptera: Corixidae) which breed at different times (Istock 1973). However, temporal partitioning does not preclude indirect competition through pre-emptive use of resources or induced host defenses (see below under Indirect Effects of Other Species).

In addition to niche partitioning, other factors also may obscure or prevent competition. Resource turnover in frequently disturbed ecosystems may prevent species saturation on available resources, and so prevent competition. Similarly, spatial patchiness in resource availability may hinder resource discovery, and therefore prevent species from reaching the abundances at which they would compete. Finally, other interactions, such as host defenses or predation, can maintain populations below sizes at which competition would occur (R. Paine 1966, 1969a, b, Tack et al. 2009, see below under Indirect Effects of Other Species).

Competition has been relatively easy to model (see Chapter 6). The Lotka–Volterra equation generalized for  $n$  competitors is

$$N_{i(t+1)} = N_{it} + r_i N_{it} \left( K - N_{it} - \sum_{j>1}^n \alpha_{ij} N_{jt} \right) / K \quad (8.1)$$

where  $N_i$  and  $N_j$  are species abundances, and  $\alpha_{ij}$  represents the per capita effect of  $N_j$  on the growth of  $N_i$  and varies for different species. For example, if competition is asymmetric, species  $j$  could have a greater negative effect (larger  $\alpha_{ij}$ ) on species  $i$  than species  $i$  has on species  $j$ .

Istock (1977) evaluated the validity of the Lotka–Volterra equations for co-occurring species of water boatmen; *Hesperocorixa lobata* (species 1) and *Sigara macropala* (species 2), in experimental enclosures (Fig. 8.3). He calculated the competition coefficients,  $\alpha_{12}$  and  $\alpha_{21}$ , as

$$\alpha_{12} = (K_1 - N_1)N_2 = 3.67 \text{ and } \alpha_{21} = (K_2 - N_2)N_1 = -0.16 \quad (8.2)$$

The intercepts of the zero isocline ( $dN/dt=0$ ) for *H. lobata* were  $K_1=88$  and  $K_1/\alpha_{12}=24$ ; the intercepts for *S. macropala* were  $K_2=6$  and  $K_2/\alpha_{21}=-38$ . The negative  $K_2/\alpha_{21}$  and position of the zero isocline for *S. macropala* indicate that the competition is asymmetric, consistent with the observation that *S. macropala* population growth was not affected significantly by the interaction (Fig. 8.3). Although niche partitioning by these two species was not clearly identified, the equations correctly predicted the observed coexistence.

## B. Predation

Predation has been defined either as a general process of feeding on other (prey) organisms (e.g., May 1981) or as a more specific process of killing and consuming prey

(e.g., Price 1997). Parasitism (and the related parasitoidism), the consumption of tissues in a living host, may or may not be included (e.g., Price 1997). Both predation and parasitism are generally considered to have positive effects for the predator or parasite, but negative effects for the prey. In this section, predation is treated as the relatively opportunistic capture of multiple prey during a predator's lifetime. The following section will address the more specific parasite–host interactions.

Although typically considered in the sense of an animal killing and eating other animals (Fig. 8.4), predation applies equally well to carnivorous plants that kill and consume insect prey, and to herbivores that kill and consume plant prey, especially those that feed on seeds and seedlings. Predator–prey and herbivore–plant interactions represent similar foraging strategies, and they are affected by similar factors (prey density and defensive strategy, predator ability to detect and orient toward various cues, etc.; see Chapter 3).

Insects and other arthropods represent major predators in terrestrial and aquatic ecosystems. The importance of many arthropods as predators of insects has been demonstrated widely through both biological control programs and experimental studies (e.g., Price 1997, D. Strong et al. 1984, van den Bosch et al. 1982, Van Driesche and Bellows 1996). However, many arthropods prey on vertebrates as well. Dragonfly larvae, water bugs, and aquatic beetles prey on fish and amphibians, as well as other invertebrates. Terrestrial ants, spiders and centipedes prey on amphibians, reptiles, and immature birds (e.g., C. Allen et al. 2004, Reagan et al. 1996).

Insects also represent important predators of plants or seeds. Some bark beetles might be considered to be predators to the extent to which they kill trees. Seed bugs, weevils and ants are effective seed predators: they often kill seedlings and may be capable of



**FIG. 8.4** Predation: Anole, *Anolis carolinensis*, with a captured crane fly (Tipulidae).

preventing plant reproduction under some conditions (e.g., Davidson et al. 1984, Turgeon et al. 1994, see Chapter 13).

Insects are important prey for a variety of other organisms. Carnivorous plants generally are associated with nitrogen-poor habitats and depend on insects for an adequate supply of nitrogen (Juniper et al. 1989, Krafft and Handel 1991). A variety of mechanisms for entrapping insects has evolved among carnivorous plants, including water-filled pitchers (pitcher plants), triggered changes in turgor pressure that close capture organs (flytraps and bladderworts), and sticky hairs (e.g., sundews). Some carnivorous plants show conspicuous ultraviolet patterns that attract insect prey (Joel et al. 1985), in a manner similar to floral attraction of some pollinators (see Chapter 3).

Insects also are prey for other arthropods (e.g., predaceous insects, spiders, mites), and vertebrates. Many fish, amphibian, reptile, bird and mammal taxa feed largely or exclusively on insects (e.g., J. Allan et al. 2003, Baxter et al. 2005, Dial and Roughgarden 1995, Gardner and Thompson 1998, C.G. Jones et al. 1998, Kawaguchi and Nakano 2001, Tinbergen 1960). Aquatic and terrestrial insects support major freshwater fisheries, including salmonids (Cloe and Garman 1996, Wipfli 1997). Terrestrial insects constitute more than half of the diets for salmonids and other insectivorous fish species, primarily during summer months (J. Allan et al. 2003, Baxter et al. 2005, Kawaguchi and Nakano 2001). Reduced availability of insect prey reduces productivity and abundance of these fish (Baxter et al. 2007). Stewart and Woolbright (1996) calculated, from gut contents, that tree frog, *Eleutherodactylus coqui*, adults, at densities of about 3300 ha<sup>-1</sup> in the Puerto Rican rainforest, consumed 10,000 insects ha<sup>-1</sup> per night; 17,000 pre-adult frogs ha<sup>-1</sup> ate an additional 100,000 insects ha<sup>-1</sup> per night. Frog gut contents consisted primarily of ants, crickets and cockroaches, three of the most abundant canopy taxa on foliage at this site.

Predation has been widely viewed as a primary regulator of prey population density (see Chapters 5 and 6). Appreciation for this lies at the heart of predator control policies which are designed to increase abundances of commercial or game species by alleviating population control by predators. However, mass starvation and declining genetic quality of populations that are protected from non-human predators have demonstrated the importance of predation in maintaining prey population vigor, or genetic structure, through selective predation on old, injured, or diseased individuals. As a result of these changing perceptions, predator reintroduction programs are being implemented in some regions. At the same time, recognition of the important role of entomophagous species in controlling populations of insect pests has justified augmentation of predator abundances, often through the introduction of exotic species, for biological control purposes (van den Bosch et al. 1982, Van Driesche and Bellows 1996, see Chapter 16). As discussed in Chapter 6, the relative importance of predation to population regulation, compared to other regulatory factors, has been a topic of considerable discussion.

Just as co-evolution between competing species has favored niche partitioning for more efficient resource use, co-evolution between predator and prey has produced a variety of defensive strategies which are balanced against predator foraging strategies. Selection favors prey that can avoid or defend against predators and favors predators that can efficiently acquire suitable prey. Prey defenses include speed, predator detection and alarm mechanisms, spines or horns, chemical defenses, cryptic, aposematic, disruptive or deceptive coloration, and behaviors (such as aggregation or warning displays) that enhance these defenses (e.g., Conner et al. 2000, Jabłoński 1999, Sillén-Tullberg 1985, see Chapters 3 and 4). Prey attributes that increase the energy cost of their capture restrict the number of predators which are able to exploit that prey.

Predator attributes that increase the efficiency with which they can capture and immobilize prey include larger size, greater speed, detection of cues that indicate vulnerable prey, claws or sharp mouthparts, venoms, and behaviors (such as ambush, flushing, or attacking the most vulnerable body parts) that compensate for or circumvent prey defenses (Jabłoński 1999, Galatowitsch and Mumme 2004, Mumme 2002), and reduce the effort necessary to capture the prey. For example, a carabid beetle, *Promecognathus laevis*, straddles polydesmid millipedes, quickly moves toward the head, pierces the neck with its mandibles and severs the ventral nerve cord, thereby paralyzing its prey and circumventing its cyanide spray defense (G. Parsons et al. 1991).

A unique strategy among predaceous insects is tool use by a tropical reduviid bug, *Salyavata variegata*, to facilitate its acquisition of termite, *Nasutitermes* spp., prey (McMahan 1982, 1983). Adult and juvenile bugs are attracted quickly to breaches in termite nests, where they can attack exposed workers. The bugs camouflage themselves with bits of carton material, to avoid detection by termite soldiers, grasp workers as they appear at the rim to investigate, then retreat a short distance to feed. Furthermore, 3<sup>rd</sup>, 4<sup>th</sup> and 5<sup>th</sup> instars employ a baiting strategy to acquire additional prey. After feeding completely on the first worker, the bug holds the termite carcass in front of its head with its forelegs, moves back to the breach as it is being repaired and pushes the carcass into the opening, jiggling it slightly. When one or more termites seize the carcass and attempt to pull it into the hole, the bug pulls the carcass and the termite that is grasping it, backward slowly, until the worker's head is in an accessible position, at which point the bug releases the carcass and grasps the new worker, then moves away from the breach to feed. One nymph was observed to feed on 31 successive termite workers over a 3 hr period.

Predators are relatively opportunistic with respect to prey taxa, compared to parasites, although prey frequently are selected on the basis of factors determining foraging efficiency. For example, chemical defenses of prey affect attractiveness to non-adapted predators (e.g., Bowers and Puttick 1988, Stamp et al. 1997, Traugott and Stamp 1996). Prey size affects the resource gained per foraging effort expended. Predators generally select prey within a size range that provides sufficient energy and nutrient rewards to balance the cost of its capture (Ernsting and van der Werf 1988, Iwasaki 1990, 1991, Richter 1990, Streams 1994, Tinbergen 1960). Within these constraints, foraging predators should attack suitable prey species in proportion to their probability of encounter, i.e., more abundant prey types are encountered more frequently than are less abundant prey types (e.g., Tinbergen 1960).

Predators exhibit both functional (behavioral) and numeric responses to prey density. Functional responses reflect predator hunger level, ability to discover prey, handling time required for individual prey, handling efficiency resulting from learning, etc. (Holling 1959, 1965, Tinbergen 1960). For many invertebrate predators, the percentage of prey captured is a negative binomial function of prey density, Holling's (1959) type 2 functional response. The ability of type 2 predators to respond individually to increased prey density is limited by their ability to capture and consume individual prey. Vertebrates, and some invertebrates, are capable of increasing their efficiency of prey discovery, e.g., through development of a search image that enhances recognition of appropriate prey (Tinbergen 1960). They also can enhance prey processing time through learning, up to a point. The percentage of prey captured increases initially as the predator learns to find and handle prey more quickly, but eventually this approaches a peak and subsequently declines when discovery and handling time reach their maximum efficiency, Holling's (1959) type 3 functional response. The type 3 functional response is better able, than the

type 2 response, to regulate prey population size(s), because of its capacity to increase the percentage of prey captured as prey density increases, at least initially. Social ants are capable of a type 3 response because of their colonial foraging, and rapid communication of the availability of prey to their nestmates. Whitford and Jackson (2007) reported that harvester ants, *Pogonomyrmex rugosus*, responded quickly to a pulse in prey availability (grass cicada emergence), taking more than 5 cicadas per minute into their nests in areas where cicada density was  $> 3 \text{ m}^{-2}$ ; however, the ants were inactive where cicada density was  $< 1 \text{ m}^{-1}$ .

Various factors affect functional response and the resulting rate of predation. The rate of prey capture tends to decline as a result of learned avoidance of distasteful prey. The maximum rate of prey capture depends on how quickly predators become satiated and on the relative abundances of palatable and unpalatable prey (Holling 1965). Some insect species, such as the periodical cicadas (*Magicicada* spp.), apparently exploit the functional responses of their major predators by appearing en masse for brief periods following long periods of inaccessibility. Predator satiation maximizes the success of such mass emergence and mating aggregations (K. Williams and Simon 1995). Palatable species experience greater predation when they are associated with less palatable species than when associated with equally or more palatable species (Holling 1965).

Numeric responses reflect predator orientation toward, and longer residence in, areas of high prey density, and subsequent reproduction in response to increased food availability. However, increased predator density also may increase competition, conflict, and intraguild predation among predators (Cardinale et al. 2006). The combination of type 3 functional response and numeric response (total response) make predators effective at cropping abundant prey and maintaining relatively stable populations of their various prey species. However, the tendency to become satiated, to reproduce more slowly than prey populations, and to show reduced per capita predation rates at high predator densities (as a result of intraguild competition and predation) limits the ability of predators to regulate irruptive prey populations that are released from other controlling factors.

The importance of predator–prey interactions to population and community dynamics has generated considerable interest in modeling this interaction. The effect of a predator on a prey population was first incorporated into the logistic model by Lotka (1925) and Volterra (1926). As described in equation 6.11, their model for prey population growth was

$$N_{1(t+1)} = N_{1t} + r_1 N_{1t} - \rho_1 N_{1t} N_{2t} \quad (8.3)$$

where  $N_2$  is the population density of the predator, and  $\rho_1$  is a predation constant. Lotka and Volterra modeled the corresponding predator population as:

$$N_{2(t+1)} = N_{2t} + \rho_2 N_{1t} N_{2t} - d_2 N_{2t} \quad (8.4)$$

where  $\rho_2$  is a predation constant and  $d_2$  is per capita mortality of the predator population. The Lotka–Volterra equations describe prey and predator populations oscillating cyclically and out of phase over time. Small changes in parameter values lead to extinction of one or both populations after several oscillations of increasing amplitude.

Pianka (1974) modified the Lotka–Volterra competition and predator–prey models to incorporate competition among prey and among predators for prey. Equation 6.12 represents the prey population:

$$N_{1(t+1)} = N_{1t} + r_1 N_{1t} - \frac{r_1 N_{1t}^2}{K_1} - \frac{r_1 N_{1t} \alpha_{12} N_{2t}}{K_1} \quad (8.5)$$

where  $\alpha_{12}$  is the per capita effect of the predator on the prey population. The corresponding model for the predator population is:

$$N_{2(t+1)} = N_{2t} + \alpha_{21} N_{1t} N_{2t} - \frac{\beta_2 N_{2t}^2}{N_{1t}} \quad (8.6)$$

where  $\alpha_{21}$  is the negative effect of predation on the prey population and  $\beta_2$  incorporates the predator's carrying capacity as a function of prey density (Pianka 1974). This refinement provided for the competitive inhibition of predator population growth as a function of the relative densities of predator and prey. The predator-prey equations have been modified further to account for variable predator and prey densities (Berlow et al. 1999), predator and prey distributions (see Begon and Mortimer 1981) and functional responses and competition among predators for individual prey (Holling 1959, 1966). Other models have been developed primarily for parasitoid-prey interactions (see below).

Current modeling approaches have focused on paired predator and prey. Real communities are composed of multiple predator species exploiting multiple prey species, resulting in complex interactions (Fig. 8.5). Furthermore, predator effects on prey are more complex than solely the direct mortality of prey. Predators also affect the distribution and behavior of prey populations. Cronin et al. (2004) found that web-building spiders, at high densities, were more likely to affect planthoppers, *Prokelisia crocea*, through induced emigration than through direct mortality. Johansson (1993) reported that immature damselflies, *Coenagrion hastulatum*, increased avoidance behavior and reduced foraging behavior when immature dragonfly, *Aeshna juncea*, predators were introduced into experimental aquaria.

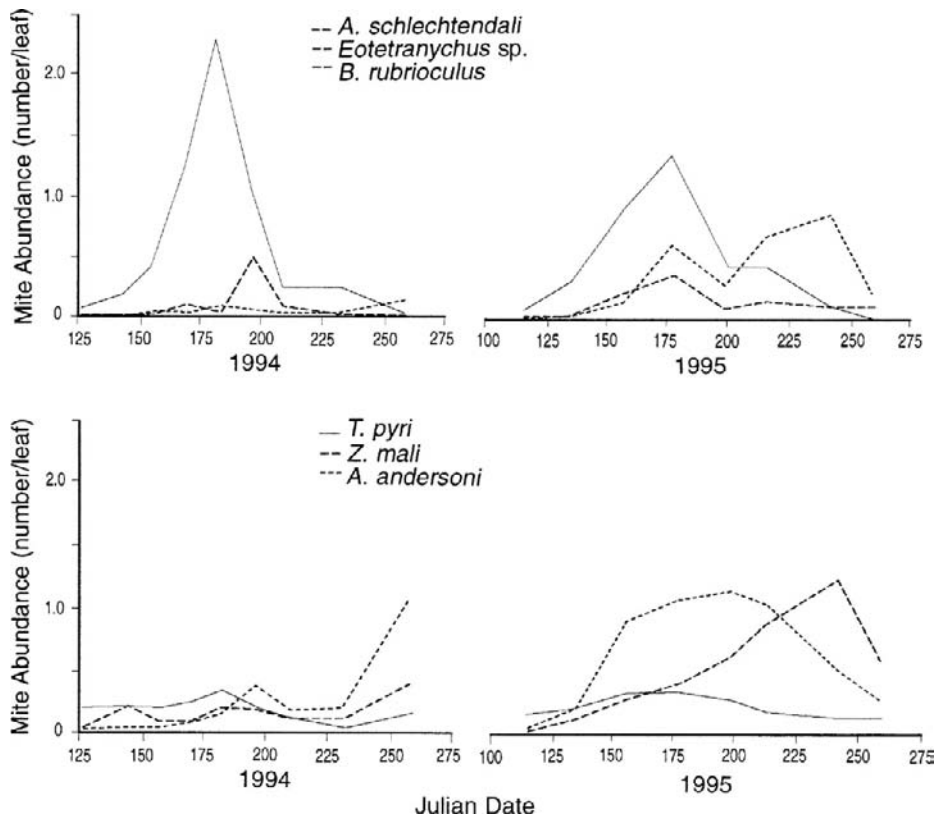
## C. Symbiosis

Symbiosis involves an intimate association between two unrelated species. Three types of interactions are considered symbiotic, although the term often has been used as a synonym for only one of these, mutualism. Parasitism describes interactions in which the symbiont derives a benefit at the expense of the host, as in predation. Commensalism occurs when the symbiont derives a benefit without significantly affecting its partner. Mutualism involves both partners benefitting from the interaction. Insects have provided some of the oldest and most interesting examples of symbiosis (Boucot and Poinar 2010, Poinar and Poinar 2007).

### 1. Parasitism

Parasitism affects the host (prey) population in ways that are similar to predation and can be described using predation models. However, whereas predation generally involves multiple prey being killed and consumed during a predator's lifetime, parasites exploit living prey. Parasitoidism is unique to insects, especially flies and wasps, and combines attributes of both predation and parasitism. The adult parasitoid typically deposits eggs or larvae on, in, or near multiple hosts, and the larvae subsequently feed on their living host and eventually kill it (Fig. 8.6). Parasites must be adapted to long periods of exposure to the defenses of a living host (see Chapter 3). Therefore parasitic interactions tend to be relatively specific associations between co-evolved parasites and their particular host species and may involve the modification of host morphology, physiology or behavior to benefit parasite development or transmission. Because of this specificity, parasites and parasitoids tend to be more effective than predators in responding to and controlling population irruptions of their hosts and, therefore, have been primary agents in biological control programs





**FIG. 8.5** Densities of three phytophagous mites, *Aculus schlechtendali*, *Bryobia rubrioculus*, and *Eotetranychus* sp. (prey), and three predaceous mites, *Amblyseius andersoni*, *Typhlodromus pyri*, and *Zetzellia mali* in untreated apple plots (N=2) during 1994 and 1995. Data from Croft and Slone (1997).

(Hochberg 1989). In fact, release from parasites, coupled with slow response by generalist predators, may largely explain the rapid spread of invasive plants and animals (Torchin and Mitchell 2004).

Parasitic interactions can be quite diverse and complex (van den Bosch et al. 1982). **Ectoparasites** feed externally, by inserting mouthparts into the host (e.g., lice, fleas, mosquitoes, ticks), and **endoparasites** feed internally, within the host's body (e.g., bacteria, nematodes, bot flies and wasps). **Primary parasites** develop on or in a non-parasitic host, whereas **hyperparasites** develop on or in another parasite. Some parasites parasitize other members of the same species (**autoparasitism** or **adelphoparasitism**), as seen in the hymenopteran, *Coccophagus scutellaris*. The female of this species parasitizes scale insects, and the male is an obligate autoparasite of the female (van den Bosch et al. 1982). **Superparasitism** occurs when more individuals occupy a host than can develop to maturity. **Multiple parasitism** occurs when more than one parasite species is present in the host simultaneously. In most cases of superparasitism and multiple parasitism, one dominant individual competitively suppresses others and develops to maturity. In a special case of multiple parasitism, some parasites preferentially attack hosts parasitized by other species (**cleptoparasitism**). The cleptoparasite is not a hyperparasite, but typically kills and consumes the original parasite as well as the host.



**FIG. 8.6** Parasitism: a parasitoid (sarcophagid fly) ovipositing on a host caterpillar at Nanjinshan Long Term Ecological Research Site, Taiwan.

Slave-making ants represent a specialized form, **social parasitism**. These ants raid colonies of neighboring ant species and capture brood, some of which are eaten, but most are reared and augment the slave maker's work force. Hare and Alloway (2001) compared the effect of two slave-making species, *Protomognathus americanus* and *Leptothorax duloticus*, on the fitness of their host ant species, *Leptothorax longispinosus*. They found that *L. longispinosus* colonies that were enclosed with *P. americanus* colonies showed no change in demographic variables, but *L. longispinosus* colonies enclosed with *L. duloticus* colonies showed significant reduction in numbers of dealate queens, workers and larvae, compared to control colonies enclosed without slave-makers. Hare and Alloway (2001) concluded that the higher abundance of *P. americanus* compared to *L. duloticus* suggests that social parasites may evolve to minimize fitness cost to their hosts.

Some parasites alter the physiology or behavior of their hosts in ways that enhance parasite development or transmission. For example, parasitic nematodes often destroy the host's genital organs, thus sterilizing the host (Tanada and Kaya 1993). Parasitized insects frequently show prolonged larval development (Tanada and Kaya 1993). Flies, grasshoppers, ants and other insects that are infected with fungal parasites often seek exposed sites before death, facilitating dispersal of emerging parasites or transmission of wind-blown spores (Henne and Johnson 2007, Tanada and Kaya 1993) (Fig. 8.7).

Insects have evolved various defenses against parasites (see Chapter 3). *Solenopsis* ants stop foraging and retreat to nests when phorid flies appear (Feener 1981, Feener and Brown 1992, Folgarait and Gilbert 1999, Mehdiabadi and Gilbert 2002, Mottern et al. 2004, Orr et al. 2003). Hard integument, hairs and spines, defensive flailing, and antibiotics secreted by metapleural glands prevent attachment or penetration by some parasites



**FIG. 8.7** Parasitism: stinkbug infected and killed by a parasitic fungus in Louisiana, U.S.

(e.g., Hajek and St. Leger 1994, Peakall et al. 1987). Ingested or synthesized antibiotics or gut modifications prevent penetration by some ingested parasites (Tallamy et al. 1998, Tanada and Kaya 1993). Endocytosis and cellular encapsulation are physiological mechanisms for destroying internal parasites (Tanada and Kaya 1993, see [Chapter 3](#)). However, some parasitic wasps inoculate hosts with a virus that inhibits encapsulation of their eggs or larvae (Edson et al. 1981, Godfray 1994).

Insects are parasitized by a number of organisms, including viruses, bacteria, fungi, protozoa, nematodes, flatworms, mites, as well as by other insects (Hajek and St. Leger 1994, Tanada and Kaya 1993, Tzean et al. 1997). Some parasites cause sufficient mortality to have been exploited as agents of biological control (van den Bosch et al. 1982, see [Chapter 16](#)). Epizootics of parasites often are responsible for termination of host outbreaks (Hajek and St. Leger 1994, Hochberg 1989). Parasites also have complex sublethal effects that make their hosts more vulnerable to other mortality factors. Bradley and Altizer (2005) reported that monarch butterflies, *Danaus plexippus*, that were parasitized by the protozoan, *Ophryocystis elektroscirrha*, lost 50% more body mass per kilometer flown and exhibited 10% slower flight velocity, 14% shorter flight duration, and 19% shorter flight distance, compared to uninfected butterflies. These data, together with much higher infection rates among non-migrating monarchs (Altizer et al. 2000), suggest that the long-distance migration of this species may eliminate infected individuals and reduce rates of parasitism.

Many insects and other arthropods are parasitic. Although parasitism generally is associated with animal hosts, most insect herbivores can be viewed as parasites of living plants, since they feed on, but rarely kill, their plant hosts ([Fig. 8.8](#)). Some herbivores, such as



**FIG. 8.8** Parasitism: a nymphalid caterpillar feeding on cecropia foliage in Puerto Rico.

sap-suckers, leaf miners and gall-formers, are analogous to the blood-feeding or internal parasites of animals. The majority of insect parasites of animals are wasps, flies, fleas and lice, but some beetle species also are parasites (e.g., Price 1997). Parasitic wasps are a highly diverse group that differentially parasitizes the eggs, juveniles, pupae or adults of various arthropods. Spider wasps, e.g., tarantula hawks, provision burrows with paralyzed spiders for their parasitic larvae. Flies parasitize a wider variety of hosts. Mosquitoes and other biting flies are important blood-sucking ectoparasites of vertebrates. Oestrid and tachinid flies are important endoparasites of vertebrates and insects. Fleas and lice are ectoparasites of vertebrates. Mites, chiggers and ticks parasitize a wide variety of hosts. Generally, parasitoids attack only other arthropods, but a sarcophagid fly, *Anolisomyia rufianalis*, is a parasitoid of *Anolis* lizards in Puerto Rico. Dial and Roughgarden (1996) found a slightly higher rate of parasitism of *Anolis evermanni*, compared to *Anolis stratulus*. They suggested that this difference may be due to black spots on the lateral abdomen of *A. stratulus* that resemble the small holes made by emerging parasites. Host-seeking flies apparently avoid lizards showing signs of prior parasitism.

Insect parasites can reduce the growth, survival, reproduction and movement of their hosts significantly (J. Day et al. 2000, Steelman 1976). Mehdiabadi and Gilbert (2002) reported that densities as low as a single phorid, *Pseudacteon tricuspis*, female per 200 foraging fire ants, *Solenopsis invicta*, reduced protein intake of the colony by > 50%, and also significantly reduced the numbers of large workers that were present 50 days later in laboratory trials. Biting flies have been reported to reduce growth and survival of wildlife species through irritation and/or blood loss (J. Day et al. 2000). DeRouen et al. (2003) reported that a 14% reduction in hornfly, *Haematobia irritans*, numbers on treated cattle resulted in a significant 14% increase in cattle weight, but showed no effect on reproductive rate. However, Sanson et al. (2003) found that reduced horn fly abundance resulted in significantly increased weight of cattle in only one of the three years of the study. Other studies of the effects of arthropod parasites of livestock also have shown that the direct

effects of parasites on host productivity are highly variable. Amoo et al. (1993) reported that a range of acaricide treatments to reduce tick, primarily *Amblyomma gemma*, parasitism of cattle had little effect on growth, reproduction, or milk production in the most and least intensive treatments. Although tick abundance in the most intensive treatment was only 14% of the abundance in the least intensive treatment, the lowest weight gain was observed in the most intensive treatment group, suggesting that reduced exposure to ticks may have prevented acquisition of resistance to tick-borne diseases.

Many arthropod parasites also vector animal pathogens, including the agents of malaria, *Plasmodium malariae*, bubonic plague, *Yersinia pestis*, and encephalitis viruses (Edman 2000). Some of these diseases cause substantial mortality in human, livestock and wildlife populations, especially when contacted by non-adapted hosts (Amoo et al. 1993, Marra et al. 2004, Stapp et al. 2004, Steelman 1976, J. Zhou et al. 2002). Human population dynamics, including invasive military campaigns, have been shaped substantially by insect-vector-borne diseases (Diamond 1999, R. Peterson 1995).

Nicholson and Bailey (1935) proposed a model of parasitoid-prey interactions that assumed that prey are dispersed regularly in a homogeneous environment, that parasitoids search randomly within a constant area of discovery, and that the ease of prey discovery and parasitoid oviposition do not vary with prey density. The number of prey in the next generation ( $u_s$ ) was calculated as:

$$pa = \log_e(u_i/u_s) \quad (8.7)$$

where  $p$  = parasitoid population density,  $a$  = area of discovery, and  $u_i$  = host density in the current generation.

Hassell and Varley (1969) showed that the area of discovery ( $a$ ) is not constant for real parasitoids. Rather  $\log a$  is linearly related to parasitoid density ( $p$ ) as:

$$\log a = \log Q - (m \log p) \quad (8.8)$$

where  $Q$  is a quest constant and  $m$  is a mutual interference constant. Hassell and Varley (1969) modified the Nicholson-Bailey model to incorporate density limitation ( $Q/p^m$ ). By substitution:

$$pa = \log_e(u_i/u_s) = Qp^{1-m} \quad (8.9)$$

as  $m$  approaches  $Q$ , model predictions approach those of the Nicholson-Bailey model.

## 2. Commensalism

Commensalism is a relatively rare type of interaction, because few hosts are completely unaffected by their symbionts. Epiphytes, plants that use their hosts for aerial support but gain their resources from the atmosphere, and cattle egrets, that eat insects flushed by grazing cattle, are well-known examples of commensalism. However, epiphytes may capture and provide nutrients to the host (a benefit) and increase the likelihood that heavy branches will break during high winds (a detriment). Examples of commensalism often may be seen as other interaction types when additional information becomes available. Some interactions involving insects may be largely commensal.

Phoretic or vector interactions (Fig. 2.13) benefit the hitchhiker or pathogen, especially when both partners have the same destination, and may have little or no effect on the host, at least up to a point where hosts become overburdened, inhibiting dispersal, resource acquisition, or escape. In some cases, phoretic partners may be mutualists, with

predaceous hitchhikers reducing competition or parasitism for their host at their destination (Kinn 1980).

A number of insect and other arthropod species are commensal in ant or termite nests. Such species are called **myrmecophiles** or **termitophiles**, respectively. These symbionts gain shelter, and often detrital food, from their host colonies, but have little, if any, effect on their hosts. This relationship is distinct from those interactions involving species that intercept host food (through trophallaxis) and, therefore, function as colony parasites. Some vertebrate species also are commensals of termite castles, which may reach several meters in height and diameter and provide critical shelter for reptile, bird and mammal species in tropical savannas (see Chapter 14).

Bark beetle galleries provide habitat and resources for a variety of invertebrate and microbial commensals, most of which have little or no effect on the bark beetles (e.g., Stephen et al. 1993). Many of the invertebrate species are fungivores or detritivores that depend on penetration of the bark by bark beetles in order to exploit resources provided by the microbial decay of wood (Fig. 8.9).

### 3. Mutualism

Mutualistic interactions tend to be relatively specific associations between co-evolved partners, and they often involve modification of host morphology, physiology or behavior to provide habitat or food resources for the symbiont. In return, the symbiont provides necessary services, resources or protection from competitors or predators. Although classic examples of mutualism often involve mutually dependent (obligate) partners, i.e., the disappearance of one leads to the demise of the other, some mutualists are less dependent on each other. Mutualism can be viewed as mutual exploitation or manipulation. Pollination



**FIG. 8.9** Commensalism: an unidentified mite in an ambrosia beetle, *Trypodendron lineatum*, mine in Douglas-fir wood. A variety of predaceous and detritivorous mites exploit resources in bark and ambrosia beetle mines.

is a by-product of insect attraction to nectar resources; some nectar-robbing species circumvent pollinia to acquire nectar. The anatomical modification and resources that maintain the interaction represent costs to the organisms involved. Provision of resources for ants by ant-protected plants requires energy and nutrients that otherwise could be allocated to growth and reproduction. Ants may provide nitrogen or other nutrients, as well as defense, for their hosts (R. Fischer et al. 2003), but plants may lose ant-related traits when ants are absent (Rickson 1977).

Mutualisms have received considerable attention, and much research has focused on examples such as pollination (see Chapter 13), ant–plant, mycorrhizae–plant interactions, and other conspicuous mutualisms. Nevertheless, Price (1997) argued that ecologists have failed to appreciate mutualism as being equal in importance to predation and competition, at least in temperate communities, reflecting a perception, based on early models, that mutualism is less stable than competition or predation (e.g., Goh 1979, May 1981, M. Williamson 1972). However, as Goh (1979) noted, such models did not appear to reflect the widespread occurrence of mutualism in ecosystems. As a cooperative relationship, mutualism can contribute greatly to the presence and ecological function of the partners, but the extent to which such positive feedback stabilizes or destabilizes interacting species populations remains a topic of discussion.

Among the best-known mutualisms are those involving pollinator and ant associations with plants (Chittka and Raine 2006, Feinsinger 1983, Huxley and Cutler 1991, Jolivet 1996). The variety of obligate relationships between pollinators and their floral hosts in the tropics has supported a perception that mutualism is more widespread and important in that region. As discussed in Chapter 13, the prevalence of obligate mutualisms between plants and pollinators in the tropics, compared to temperate regions, largely reflects the high diversity, of plant species, that precludes wind pollination between nearest neighbors. Sparsely-distributed or understory plants in temperate regions also tend to have mutualistic associations with pollinators. Some mutualistic associations (e.g., insect–microbial association, see below) may be more prominent in temperate than in tropical regions.

Many plants provide nest sites or shelters (domatia), e.g., in hollow stems or pilose vein axils, for ants or predaceous mites that protect the plant from herbivores (R. Fischer et al. 2002, O’Dowd and Willson 1991). Cecropia trees, *Cecropia* spp., in the tropics are protected from herbivores by aggressive ants, *Azteca* spp., which are housed in hollow stems (Rickson 1977). Central American acacias, *Acacia* spp., also are defended by colonies of aggressive ants, *Pseudomyrmex* spp., housed in swollen thorns (Janzen 1966). Other plant species provide extrafloral nectaries which are rich in amino acids and lipids that attract ants (e.g., Dreisig 1988, Jolivet 1996, Oliveira and Brandão 1991, Rickson 1971, Schupp and Feener 1991, Tilman 1978). In addition to defense, plants also may acquire nitrogen or other nutrients from the ants (R. Fischer et al. 2003).

Clarke and Kitching (1995) discovered an unusual mutualistic interaction between an ant and a carnivorous pitcher plant in Borneo. The ant, *Camponotus* spp., nests in hollow tendrils of the plant, *Nepenthes bicalcarata*, and is capable of swimming in pitcher plant fluid, where it feeds on large prey items that have been caught in the pitcher. Through ant-removal experiments, Clarke and Kitching found that the accumulation of large prey (but not small prey) in ant-free pitchers led to putrefaction of the pitcher contents and disruption of prey digestion by the plant. By removing large prey, the ants prevented putrefaction and accumulation of ammonia.

Seed-feeding ants often benefit plants by dispersing non-consumed seeds. This mutualism is exemplified by myrmecochorous plants that provide a nutritive body (elaiosome)

attached to the seed to attract ants. The elaiosome is typically rich in lipids (Gorb and Gorb 2003, Jolivet 1996). The likelihood that a seed will be discarded in or near an ant nest following removal of the elaiosome increases with elaiosome size, perhaps reflecting increasing use by the seed disperser, rather than seed predator, species with increasing elaiosome size (Gorb and Gorb 2003, Mark and Olesen 1996, Westoby et al. 1991). The plants benefit primarily through seed dispersal by ants (Horvitz and Schemske 1986, Ohkawara et al. 1996), though not necessarily from seed relocation to more nutrient-rich microsites (Horvitz and Schemske 1986, Westoby et al. 1991, see Chapter 13). This interaction has been implicated in the rapid invasion of new habitats by myrmecochorous species (J.M. Smith 1989).

Gressitt et al. (1965, 1968) reported that large phytophagous weevils in the genera *Gymnopholus* and *Pantorhytes* host diverse communities of cryptogamic plants, including fungi, algae, lichens, liverworts and mosses, on their elytra. These weevils have specialized scales or hairs and produce a thick, waxy secretion from glands around depressions in the elytra which appear to foster the growth of these symbionts. In turn, the weevils benefit from the camouflage provided by this growth and, possibly, from chemical protection. Predation on these weevils appears to be rare.

Insects engage in a variety of mutualistic interactions with microorganisms. Parasitoid wasps inoculate their host with a virus that prevents cellular encapsulation of the parasitoid larva (Edson et al. 1981, Godfray 1994, see Chapter 3). Intestinal bacteria may synthesize some of the pheromones used by bark beetles to attract mates (Byers and Wood 1981). Most aphids harbor mutualistic bacteria or yeasts, in specialized organs (bacteriomes or mycetomes), that appear to provide amino acids, vitamins and/or proteins necessary for aphid development and reproduction (Baumann et al. 1995). Experimental elimination of the microbes results in aphid sterility, reduced weight and reduced survival. Many hemipterans vector plant pathogens and may benefit from the changes in host condition that are induced by infection (Kluth et al. 2002). Leaf-cutting ants, *Atta* spp. and *Acromyrmex* spp., cultivate fungus gardens that provide food for the ants (e.g., C. Currie 2001, Weber 1966).

Virtually all wood-feeding species interact mutualistically with cellulose-digesting microorganisms. Ambrosia beetles (Scolytinae and Platypodinae) are the only means of transport for ambrosia (mold) fungi, carrying hyphae in specialized invaginations of the cuticle (mycangia) that secrete lipids for fungal nourishment, and require the nutrition provided by the fungus. The adult beetles carefully cultivate fungal gardens in their galleries, removing competing fungi. Their offspring feed exclusively on the fungus, which derives its resources from the wood surrounding the gallery, and collect and transport fungal hyphae when they disperse (Batra 1966, French and Roesper 1972).

Siricid wasps are the only means of dispersal for associated *Amylostereum* (decay) fungi, and larvae die in the absence of the fungus (Morgan 1968). The adult female wasp collects fungal hyphae from its gallery prior to exiting, stores and nourishes the fungus in a mycangium at the base of the ovipositor, then introduces the fungus during oviposition in the wood. The wasp larva feeds on the fungal mycelium, destroying it in the gut, and passes decayed wood fragments around the body to combine posteriorly with its frass. Phloem-feeding bark beetles transport mycangial fungi and bacteria as well as opportunistic fungi. M. Ayres et al. (2000) reported that mycangial fungi significantly increased nitrogen concentrations in the phloem surrounding southern pine beetle, *Dendroctonus frontalis*, larvae, compared to uncolonized phloem. Opportunistic fungi, including *Ophiostoma minus*, did not concentrate nitrogen in phloem surrounding larvae, suggesting



that the apparent antagonism between this fungus and the bark beetle may reflect failure to enhance phloem nutrient concentrations (see below). Termites similarly depend on mutualistic bacteria or protozoa in their guts for the digestion of cellulose (Breznak and Brune 1994).

Many mutualistic interactions pair insects with other arthropods. Hemiptera, especially aphids, excrete much of the carbohydrate solution (honeydew) that composes plant sap in order to concentrate sufficient nutrients (see Chapter 3). Honeydew attracts ants that provide protection from predators and parasites (Fig. 8.10, Bristow 1991, Dixon 1985, Dreisig 1988). This mutualism involves about 25% of aphid species and varies in interaction strength and benefits, perhaps reflecting plant chemical influences or the relative costs of defending aphid colonies (Bristow 1991). Ant species show different preferences among aphid species, and the efficiency of protection often varies inversely with aphid and ant densities (Bristow 1991, Cushman and Addicott 1991, Dreisig 1988).

Dung beetles (Scarabaeidae) and bark beetles often have mutualistic associations with phoretic, predaceous mites. The beetles are the only means of long-distance transport for the mites, and the mites feed on the competitors or parasites of their hosts (Kinn 1980, Krantz and Mellott 1972).

Models of mutualistic interactions have lagged behind models for competitive or predator-prey interactions, largely because of the difficulty of simultaneously incorporating negative (density limitation) and positive (density increasing) feedback. The Lotka-Volterra equations may be inadequate for extension to mutualism, because they lead to unbounded exponential growth of both populations (May 1981, but see Goh 1979). May (1981) asserted that minimally realistic models for mutualists must allow for saturation in the magnitude of at least one of the reciprocal benefits, leading to a stable equilibrium point, with one



**FIG. 8.10** Mutualism: ant tending honeydew-producing aphids in Georgia, U.S. Photo courtesy of S.D. Senter.

(most often both) of the two equilibrium populations being larger than that which would be sustained in the absence of the interaction. However, recovery from perturbations to this equilibrium may take longer than it would in the absence of interaction, leading to instability (May 1981). May (1981) presented a simple model for two mutualists:

$$N_{1(t+1)} = N_{1t} + r_1 N_{1t} [1 - (N_{1t} + \alpha N_{2t}) / K_1] \quad (8.10)$$

$$N_{2(t+1)} = N_{2t} + r_2 N_{2t} [1 - (N_{2t} + \beta N_{1t}) / K_2] \quad (8.11)$$

in which the carrying capacity of each population is increased by the presence of the other, with  $\alpha$  and  $\beta$  representing the beneficial effect of the partner,  $K_1 \rightarrow K_1 + \alpha N_2$ ,  $K_2 \rightarrow K_2 + \beta N_1$ , and  $\alpha\beta < 1$  to limit uncontrolled growth of the two populations. The larger the product,  $\alpha\beta$ , the more tightly coupled are the mutualists. For obligate mutualists, a threshold effect must be incorporated to represent the demise of either partner if the other becomes rare or absent. May (1981) concluded that mutualisms are stable when both populations are relatively large and are increasingly unstable at lower population sizes, with a minimum point for persistence.

Dean (1983) proposed an alternative model that incorporates density dependence as the means by which two mutualists can reach a stable equilibrium. As a basis for this model, Dean described the relationship between population carrying capacity ( $k_y$ ) and an environmental variable ( $M$ ) that limits  $k_y$ :

$$dk_y/dM = a(K_y - k_y)/K_y \quad (8.12)$$

where  $K_y$  is the maximum value of  $k_y$  and the constant  $a$  is reduced by  $a$  linear function of  $k_y$ . This equation can be integrated as:

$$k_y = K_y (1 - e^{-(aM + C_y)/K_y}) \quad (8.13)$$

where  $C_y$  is the integration constant. Equation (8.13) describes the isocline where  $dY/dt = 0$ .

For a species,  $Y$ , exploiting a replenishable resource provided by species  $X$ , Equation (8.13) can be rewritten as:

$$k_y = K_y (1 - e^{-(aN_x + C_y)/K_y}) \quad (8.14)$$

where  $N_x$  is the number of species  $X$ . The carrying capacity of species  $X$  depends on the value of  $Y$  and can be described as:

$$k_x = K_x (1 - e^{-(bN_y + C_x)/K_x}) \quad (8.15)$$

where  $N_y$  is the number of species  $Y$ . Mutualism will be stable when the number of one mutualist ( $N_y$ ), maintained by a certain number of the other mutualist ( $N_x$ ), is greater than the  $N_y$  necessary to maintain  $N_x$ . When this condition is met, both populations will grow until density effects limit the population growth of  $X$  and  $Y$ , so that isoclines defined by Equations (8.14) and (8.15) inevitably intersect at a point of stable equilibrium. Mutualism cannot occur when the isoclines do not intersect and is unstable when the isoclines are tangential. This condition is satisfied when any value of  $N_x$  or  $N_y$  can be found to satisfy either of the following equations:

$$K_y (1 - e^{-(aN_x + C_y)/K_y}) > -(C_x + K_x [\ln(K_x - N_x) - \ln K_x]) / b \quad (8.16)$$

$$K_x (1 - e^{-(bN_y + C_x)/K_x}) > -(C_y + K_y [\ln(K_y - N_y) - \ln K_y]) / a \quad (8.17)$$

The values of the constants,  $C_x$  and  $C_y$ , in equations (8.14) and (8.15) indicate the strength of mutualistic interaction. When  $C_x$  and  $C_y > 0$ , the interacting species are facultative mutualists; when  $C_x$  and  $C_y = 0$ , both species are obligate mutualists; when  $C_x$  and  $C_y < 0$ , both species are obligate mutualists, and their persistence is determined by threshold densities.

The growth rates of the two mutualists can be described by modified logistic equations as:

$$N_{y(t+1)} = N_{y(t)} + (r_y N_{y(t)} [k_y - N_{y(t)}]) / k_y \quad (8.18)$$

$$N_{x(t+1)} = N_{x(t)} + (r_x N_{x(t)} [k_x - N_{x(t)}]) / k_x \quad (8.19)$$

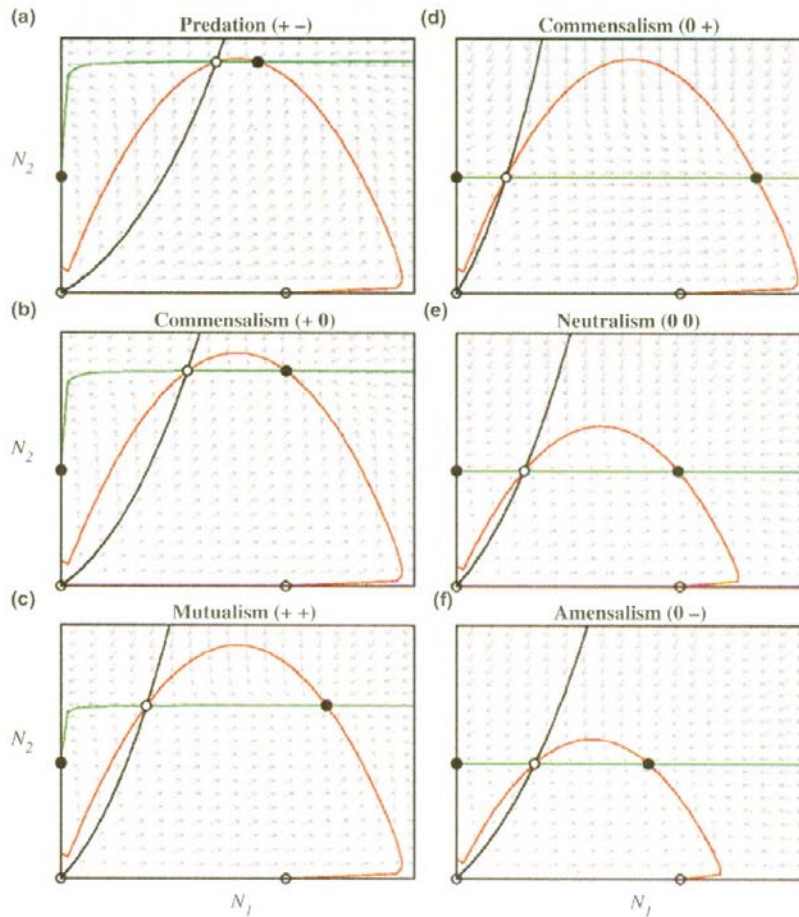
where  $r_y$  and  $r_x$  are the intrinsic rates of increase for species  $y$  and  $x$ , respectively. However,  $k_y$  and  $k_x$  are not constants but are determined by equations (8.14) and (8.15).

More recently, Holland and DeAngelis (2009) demonstrated that mutualism could be modeled using extensions of the Lotka–Volterra equations for species interaction, but varying parameter values for interaction strength ( $\alpha_{ij}$ ) and resource supply by one species to the other ( $\beta_{ij}$ ) (Figure 8.11). Their model allowed for shifts in mutualistic interaction from stable co-existence to overexploitation by one or the other species, depending on environmental conditions.

## II. FACTORS AFFECTING INTERACTIONS

Multi-species interactions are highly complex (e.g., M. Wise 2009). Species can simultaneously compete for space and enhance each other's food acquisition (mutualism), as described by Cardinale et al. (2002) for three caddis fly species that, in combination increase substrate surface heterogeneity and near-surface velocity and turbulent flow that control food delivery (see below). The strength, and even type, of interaction can vary over time and space depending on biotic and abiotic conditions (e.g., B. Inoué and Stinchcombe 2001, Økland et al. 2009, Tilman 1978). Interactions can change during life history development or can differ between the sexes. For example, immature butterflies (caterpillars) are herbivores, but adult butterflies are pollinators. Insects with aquatic immatures are terrestrial as adults. Immature males of the strepsipteran family Myrmecolacidae parasitize ants, whereas immature females parasitize grasshoppers (de Carvalho and Kogan 1991). Herbivore–plant interactions may be largely mutualistic at low herbivore population densities, with the plant providing food and the herbivore providing limited pruning, but increasingly parasitic, or even predatory, at high herbivore densities (see Chapter 12). Holland and DeAngelis (2009) demonstrated that all possible outcomes of species interactions emerged simply from changes in parameters of consumer–resource relationships (interaction strength and direction of exploitation), indicating that changes in abiotic or biotic conditions could alter outcomes of species interactions (Figure 8.11).

The strength of interaction depends on the proximity of the two species, their ability to perceive each other, their relative densities, and their motivation to interact. These factors in turn are affected by abiotic conditions, resource availability, and indirect effects of other species. Modeling interaction strength in order to predict community dynamics has taken a variety of approaches that may be subject to unrecognized biases or to non-linear or indirect effects (Abrams 2001, Berlow et al. 1999).



**FIG. 8.11** Phase-plane diagrams for population dynamics of one-way consumer–resource interactions between two species with populations densities  $N_1$  and  $N_2$ . The sequence of panels shows how changes in interactions strengths ( $\alpha_{ij}$ = per capita interaction strength of species  $j$  on species  $i$ ) and resource supply ( $\beta_i$ = saturation level of resources exploited of species  $i$ ) lead to dynamic transitions between (a) predation ( $r_1=0.7$ ,  $r_2=0.5$ ,  $\alpha_{12}=0.4$ ,  $\alpha_{21}=0.5$ ,  $b_1=0.3$ ), (b) commensalism (Species 1 benefits  $r_1=0.7$ ,  $r_2=0.5$ ,  $\alpha_{12}=0.4$ ,  $\alpha_{21}=0.435$ ,  $b_1=0.3$ ), (c) mutualism ( $r_1=0.7$ ,  $r_2=0.5$ ,  $\alpha_{12}=0.4$ ,  $\alpha_{21}=0.25$ ,  $b_1=0.3$ ), (d) reverse commensalism (Species 2 benefits  $r_1=0.7$ ,  $r_2=0.5$ ,  $\alpha_{12}=0.4$ ,  $\alpha_{21}=0$ ,  $b_1=0.3$ ), (e) neutralism ( $r_1=0.7$ ,  $r_2=0.5$ ,  $\alpha_{12}=0.21$ ,  $\alpha_{21}=0$ ,  $b_1=0.3$ ), and (f) amensalism ( $r_1=0.7$ ,  $r_2=0.5$ ,  $a_{12}=0.15$ ,  $a_{21}=0$ ,  $b_1=0.3$ ). The red and green lines are zero-growth isoclines for  $N_1$  and  $N_2$ , respectively. Grey arrows designate vector fields in phase-plane space and denote direction and speed (size/length of arrow) of population trajectories for particular points throughout phase-plane space. Stable and unstable nodes are identified by filled and open circles, respectively. Saddle points have a black line passing through them to the origin. Starting with the origin and moving clock-wise, the equilibria for each panel are unstable node, stable node, saddle point, stable node and saddle point. From Holland and DeAngelis (2009) with permission from John Wiley & Sons.

## A. Abiotic Conditions

Relatively few studies have addressed the effects of abiotic conditions on species interactions. J. Chase (1996) experimentally manipulated temperature and solar radiation in grassland plots which contained grasshoppers and wolf spiders. When temperature and

solar radiation were reduced by shading, grasshopper activity was reduced, but spider activity was unaffected, and the spiders reduced grasshopper density. In contrast, grasshoppers remained active in unshaded plots, and spiders did not reduce grasshopper density. Stamp and Bowers (1990) found that temperature affects interactions between plants, herbivores, and predators.

Priesser and Strong (2004) reported that neither a root-feeding lepidopteran herbivore, *Hepialus californicus*, nor its lupine host, *Lupinus arboreus*, was affected directly by variation in soil moisture, but outbreaks typically coincide with drought conditions. An experimental increase in soil moisture during a dry year demonstrated that high soil moisture favored parasitic nematodes, *Heterorhabditis marelatus*, that suppressed the herbivore outbreak and protected the plant host via trophic cascade.

Hart (1992) studied the effect of water flow on the relationship between crayfish, caddisfly prey, and algal food base in a stream ecosystem. He found that the foraging activity of the crayfish was impaired at high flow rates, limiting predation on caddisfly grazers and altering the algae–herbivore interaction. Kelly et al. (2003) reported that exposure of stream communities to UV radiation reduced aquatic grazing and led to increased algal biomass.

Abiotic conditions that affect host growth or defensive capability influence predation or parasitism. An increase in exposure to sunlight can increase the production of defensive compounds by plants and reduce herbivory (Dudt and Shure 1994, Niesenbaum 1992). Stamp et al. (1997) found that defensive chemicals that were sequestered by caterpillars had greater negative effects on a predator at higher temperatures. Light availability to plants may affect their relative investment in toxic compounds vs. extrafloral nectaries and domatia to facilitate defense by ants (Davidson and Fisher 1991). Fox et al. (1999) reported that drought stress in the U.K. did not affect growth of St. John's wort, *Hypericum perforatum*, directly but increased plant vulnerability to herbivores.

Altered atmospheric chemistry, e.g., CO<sub>2</sub> enrichment or pollutants, affects interactions (Alstad et al. 1982, Arnone et al. 1995, V.C. Brown 1995, Heliövaara and Väisänen 1986, 1993, Kinney et al. 1997, Roth and Lindroth 1994, Salt et al. 1996). Hughes and Bazzaz (1997) reported that elevated CO<sub>2</sub> concentrations significantly increased the C to N ratio and decreased the percentage of nitrogen in milkweed, *Asclepias syriaca*, tissues, resulting in lower densities but greater per capita leaf damage by western flower thrips, *Frankliniella occidentalis*. However, the increased plant growth at elevated CO<sub>2</sub> levels more than compensated for the leaf damage. Mondor et al. (2004) found that the aphid, *Chaitophorus stevensis*, exhibited reduced predator-escape behavior in an enriched CO<sub>2</sub> atmosphere but greater escape behavior in an enriched O<sub>3</sub> atmosphere, compared to ambient atmospheric conditions. Elevated CO<sub>2</sub> can affect litter quality and alter interactions among litter flora and fauna (Coûteaux et al. 1991). Ozone, but not nitrogen dioxide or sulphur dioxide, interfered with searching behavior and host discovery by a braconid parasitoid, *Asobara tabida* (Gate et al. 1995).

Disturbances affect species interactions in several ways. First, disturbances reduce abundances of intolerant species, thereby affecting their interactions with other species. Second, disturbances contribute to landscape heterogeneity, thereby providing potential refuges from predation (e.g., Denslow 1985, Kruess and Tschardt 1994, Schowalter and Ganio 1999) but also decoupling positive interactions.

## B. Resource Availability and Distribution

Resource availability affects competition and predation. If suitable resources (plants or animal prey) become more abundant, resource discovery becomes easier, and consumer

populations grow. Increased probability of close contact and competition among consumers leads to densities at which superior competitor(s) suppress or exclude inferior competitors. As a result, the intensity of interspecific competition may peak at intermediate levels of resource availability, although the overall rate of resource use may continue to rise with increasing availability (depending on functional and numerical responses). Population outbreaks reduce resource availability and also reduce populations of competing species.

Interactions are affected by landscape heterogeneity. Sparse resources in heterogeneous habitats tend to maintain small, low-density populations of associated species. The energetic and nutrient costs of detoxifying current resources or searching for more suitable resources limit growth, survival and reproduction (see Chapters 3 and 4). Under these conditions, potentially interacting species are decoupled in time and space, co-occurring infrequently among landscape patches (Covich et al. 2009, Tack et al. 2009). Hence, competition is minimized, and predator-free space is maximized. In contrast, more homogeneous environments facilitate population spread of associated species and maximize the probability of co-occurrence.

Palmer (2003) explored the effect of termite-generated heterogeneity in resource availability on the competitive interactions of four ant species that reside on acacia, *Acacia drepanolobium*, in East Africa. Only one ant species occupied an individual tree at any given time, and violent interspecific competition for host trees by adjacent colonies was common. Acacia shoot production and densities of litter invertebrates increased with proximity to termite mounds. The competitively dominant ant, *Crematogaster sjostedti*, displaced other acacia ants, *Crematogaster mimosae*, *Crematogaster nigriceps*, and *Tetraponera penzigi*, near termite mounds, whereas the probability of subordinate species displacing *C. sjostedti* increased with distance from termite mounds. This variation in the outcome of competition for acacia hosts appeared to result from differential responses among the ant species to resource heterogeneity on the landscape.

Species interactions also affect habitat heterogeneity and/or resource availability. Cardinale et al. (2002) manipulated the composition of three suspension-feeding caddisfly species at the same total density in experimental stream mesocosms. They reported that the total consumption of suspended particulate food was 66% higher in mixtures, compared to single-species treatments. Facilitation of food capture by these potentially competing species in mixture resulted from increased stream bed complexity (reflecting variation in silk catchnet size), which in turn increased eddy turbulence and near-bed velocity, factors that controlled the rate of food delivery.

### C. Indirect Effects of Other Species

Research has focused on pairs of species that interact directly, i.e., through energy or material transfers, as described above. Indirect interactions have received less attention but may be at least as important. Pollinators can augment plant reproduction sufficiently to compensate for herbivory, thereby indirectly affecting plant–herbivore interaction (L. Adler et al. 2001, Strauss and Murch 2004). On the other hand, Segraves (2008) demonstrated that a florivorous beetle, *Hymenorus densus*, consumed 1–2 yucca moth eggs, *Tegeticula cassandra*, per yucca flower, *Yucca filamentosa*, thereby increasing seed production per flower by 16–32%. These results indicated that the beetle limits yucca moth populations and reduces the costs to the yucca of its mutualism with the yucca moth. Batzer et al. (2000b) reported that the indirect effects of predaceous fish on invertebrate predators

and competitors of midge prey had a greater effect on midge abundance than did direct predation on midges.

Tri-trophic level interactions are recognized as having indirect effects on both herbivore–plant and predator–prey interactions (e.g., Boethel and Eikenbary 1986, Price et al. 1980). Even these interactions represent highly simplified models of communities (Gutierrez 1986, C.G. Jones et al. 1998) in which species potentially interact directly or indirectly with hundreds of other species to alter environmental conditions for all (see Chapters 9 and 10). Bezemer et al. (2005) reported that manipulation of soil nematodes and microorganisms significantly altered the amino acid and phenolic content of plants, thereby altering aphid and parasitoid performance. The abundance of tick vectors of lyme disease is related to the abundance of small mammal reservoirs, which reflect acorn production that, in turn, is affected by gypsy moth, *Lymantria dispar*, defoliation (C.G. Jones et al. 1998). The tendency for multiple interactions to stabilize or destabilize species populations and community structure has been debated (Goh 1979, May 1973, 1983, Price 1997). May (1973) proposed that community stability depends on predator–prey interactions (negative feedback) being more common than mutualistic interactions (positive feedback). Because multi-species interactions control rates of energy and nutrient fluxes through ecosystems, resolution of the extent to which indirect interactions reduce variation in community structure will contribute significantly to our understanding of ecosystem stability.

Associated species affect particular interactions in a variety of ways. Much research has addressed the negative effects of plant defenses induced by early-season herbivores on later colonists (Fig. 8.12) (e.g., Harrison and Karban 1986, M.D. Hunter 1987, Kogan and Paxton 1983, N. Moran and Whitham 1990, Sticher et al. 1997, Van Zandt and Agrawal 2004, Wold and Marquis 1997) and on decomposers (Grime et al. 1996). K. Anderson et al. (2009) extended the Lotka–Volterra competition model to describe plant-mediated interactions between two herbivore species. Their model for induction of multiple plant traits with negative or positive effects on a second herbivore is:

$$H_{1(t+1)} = H_{1t} + r_1 H_1 ((K_1 - H_1 - f_1 I_2 + g_1 I_1 / K_1)) \quad (8.20)$$

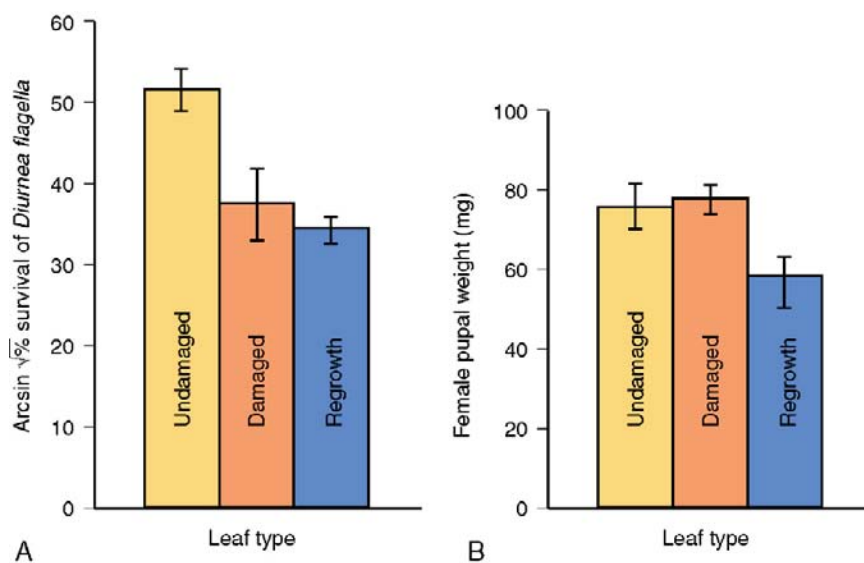
$$H_{2(t+1)} = H_{2t} + r_2 H_2 ((K_2 - H_2 - f_2 I_1 + g_2 I_2 / K_2)) \quad (8.21)$$

$$I_{1(t+1)} = I_{1t} + p_1 (I_1, H_1) - \delta_1 I_1 \quad (8.22)$$

$$I_{2(t+1)} = I_{2t} + p_2 (I_2, H_2) - \delta_2 I_2 \quad (8.23)$$

where  $H_1$  and  $H_2$  are herbivores 1 and 2, respectively,  $I_1$  and  $I_2$  are induced responses of the plant with effect strength  $f$  and  $g$ , respectively, and  $\delta_1 I_1$  and  $\delta_2 I_2$  represent decay in induction over time.

Herbivore-induced defenses can affect interactions with other members of the community, as well. Callaway et al. (1999) reported that the tortricid moth, *Agapeta zoegana*, introduced to the western U.S. for biological control of spotted knapweed, *Centaurea maculosa*, increased the negative effect of its host on native grass, *Festuca idahoensis*. The reproductive output of the grass was lower when neighboring knapweed had been defoliated by the moth, compared to grass that was surrounded by non-defoliated neighbors. Callaway et al. (1999) suggested that defenses induced by the moth also had allelopathic effects on neighboring plants or altered root exudates that affected competition via soil microbes.

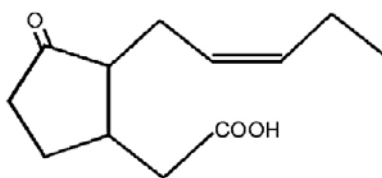


**FIG. 8.12** Differential survival to pupation A) and mean female pupal weight B) of *Diurnea flagella* on foliage that was undamaged, naturally damaged by folivores, and produced following damage. Vertical lines represent standard errors of the mean. *D. flagella* larvae feeding on regrowth foliage show both reduced survival to pupation and reduced pupal weight. From M.D. Hunter (1987) with permission from John Wiley & Sons.

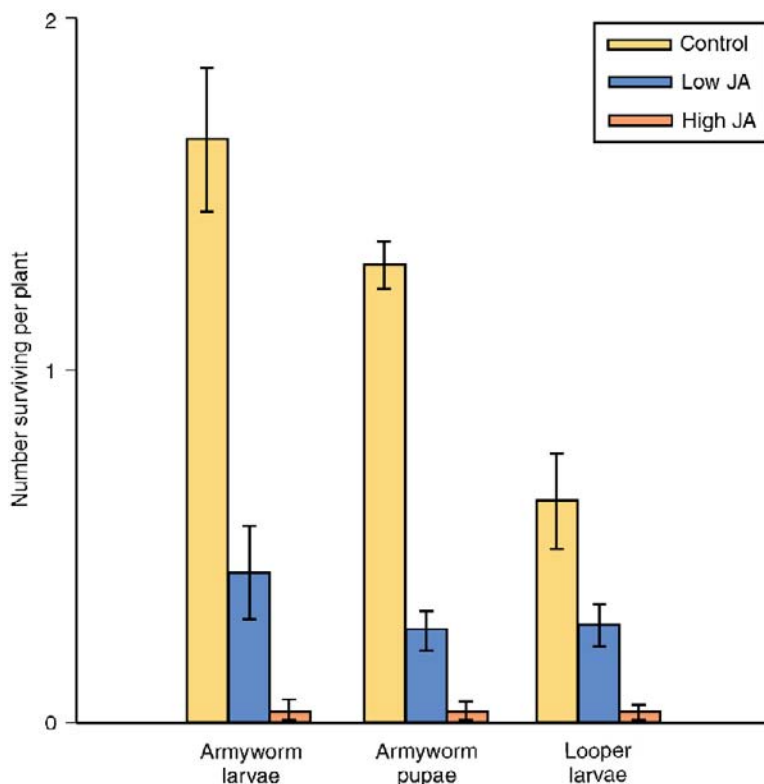
Baldwin and Schultz (1983) and Rhoades (1983) independently found evidence that damage by herbivores is communicated chemically among plants, leading to induction of defense in plants in advance of herbivory (see Chapter 3). Although their hypothesis that plants communicate the herbivore threat chemically with each other was challenged widely because of its apparent incongruency with natural selection theory (e.g., Fowler and Lawton 1985), numerous studies have confirmed the induction of chemical defenses by volatile chemical elicitors, particularly jasmonic acid (Fig. 8.13), salicylic acid and ethylene (Farmer and Ryan 1990, McCloud and Baldwin 1997, Schmelz et al. 2002, Sticher et al. 1997, Thaler 1999a, Thaler et al. 2001, see Chapter 3). Jasmonate induces the production of proteinase inhibitors and other defenses against multiple insects and pathogens when applied at low concentrations to a variety of plant species (Fig. 8.14, Chamberlain et al. 2001, Hudgins et al. 2003, 2004, Thaler et al. 2001). Inter-plant communication via jasmonate induces production of defenses among neighboring plants (Fig. 8.15, Dolch and Tschardtke 2000, Hudgins et al. 2004, M. Stout et al. 2006, Tschardtke et al. 2001), including unrelated plant species (Farmer and Ryan 1990, Karban 2001, Karban and Maron 2002, Karban et al. 2000, Schmelz et al. 2002, Thaler et al. 2001), although the fitness consequences of interspecific communication are not clear (Karbon and Maron 2002).

Plant defense elicitors also affect herbivores indirectly through other associated species. Thaler (1999b) demonstrated that tomato, *Lycopersicon esculentum*, defenses that were induced by jasmonate treatment doubled the rate of parasitism of armyworm, *Spodoptera exigua*, by the wasp, *Hyposoter exiguae*. However, some induced proteinase inhibitors may reduce the pupal weight and survival of attracted parasitoids (Rodriguez-Saona et al. 2005). Zeng et al. (2009) found that herbivore production of P450 detoxification enzymes in response to





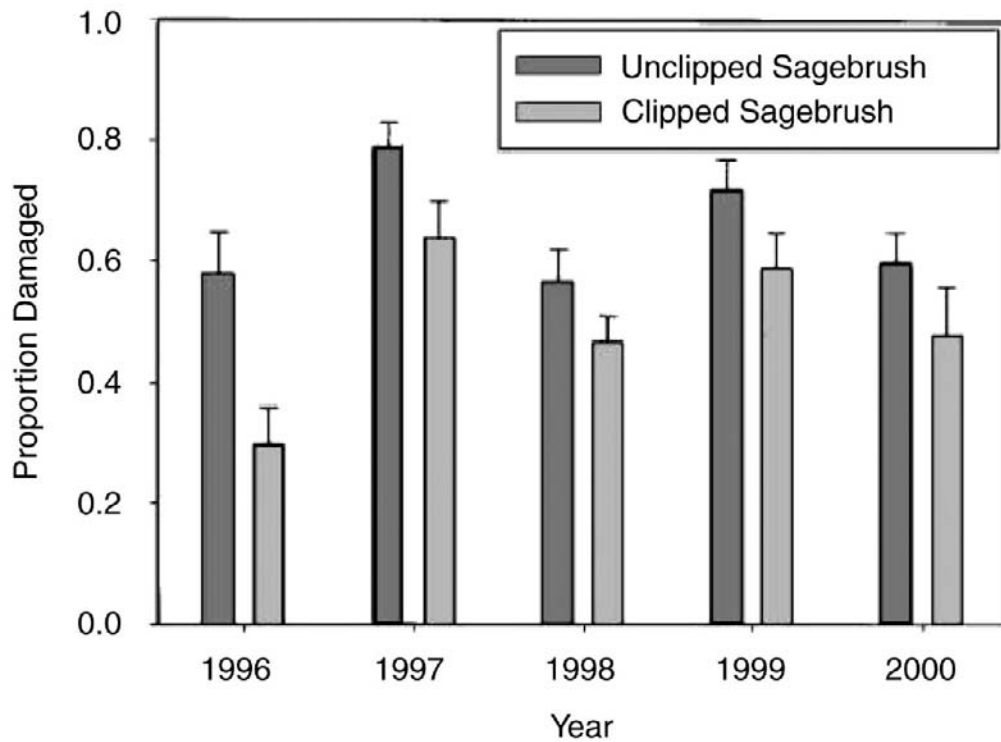
**FIG. 8.13** Structure of jasmonic acid, a volatile plant chemical that communicates plant damage and induces defensive chemical production in neighboring plants.



**FIG. 8.14** Survival of beet armyworm, *Spodoptera exigua*, larvae and pupae and cabbage looper, *Trichoplusia ni*, larvae on field-grown tomatoes sprayed with low (0.5 mM) or high (1.5 mM) doses of jasmonic acid, or unsprayed (control). Vertical lines represent 1 SE. From Thaler et al. (2001) with permission from John Wiley & Sons.

plant signaling chemicals, an adaptive response to induced plant defense, increased the toxicity of aflatoxins ingested with plant material (Fig. 8.16, see next paragraph).

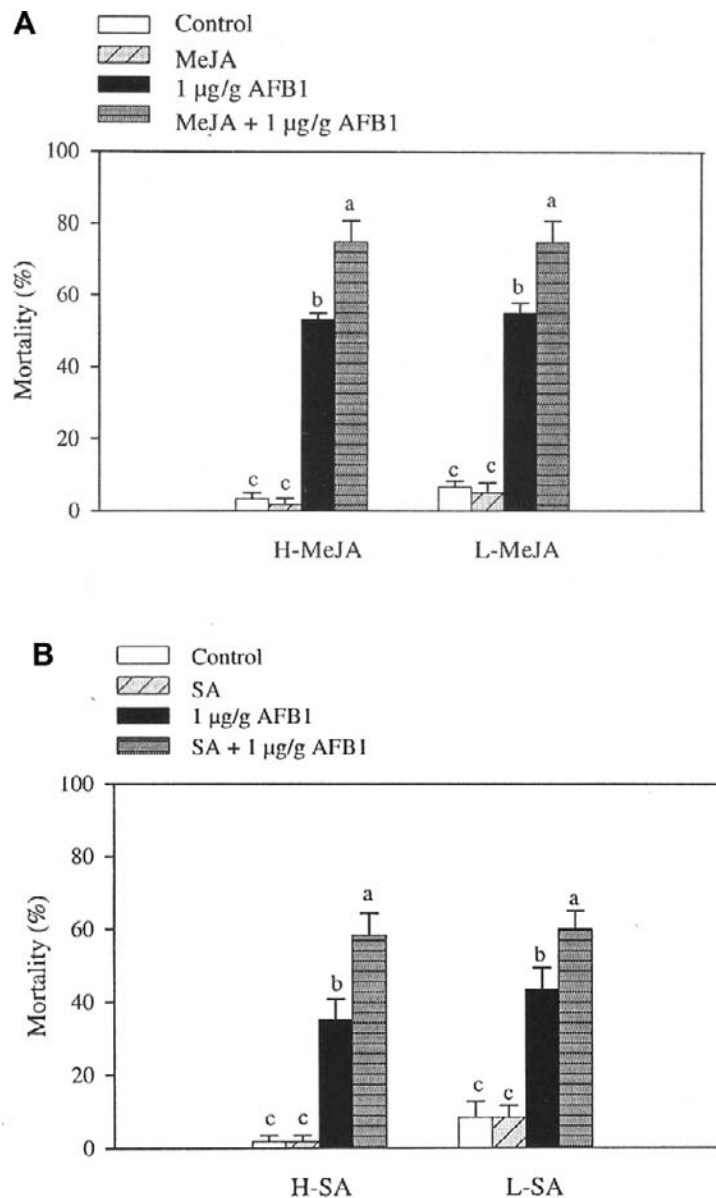
Endophytic or mycorrhizal fungi affect interactions between other organisms (E. Allen and Allen 1990, G. Carroll 1988, Clay 1990, Chapter 3). G. Carroll (1988) and Clay et al. (1985) reported that mycotoxins produced by mutualistic endophytic fungi can complement host defenses in deterring insect herbivores. Clay et al. (1993) documented the complex effects of insect herbivores and endophytic fungi on the competitive interactions among grass species. Tall fescue, *Festuca arundinacea*, competed poorly with



**FIG. 8.15** Maximum proportion of leaves that were damaged by grasshoppers on tobacco plants that were near sagebrush plants that were artificially clipped or unclipped (mean  $\pm$  SE). Effects of clipping were significant all five years ( $P < 0.0001$ ). Reprinted from Karban, (2001), with permission from Elsevier.

orchard grass, *Dactylis glomerata*, when herbivores were absent, but fescue which was infected with its fungal endophyte, *Acremonium* spp., competed better than either orchard grass or uninfected fescue when herbivores were present. Mycorrhizae transport nutrients among plants through the hyphal network, mediating plant competition (E. Allen and Allen 1990). Gange et al. (1999) and Goverde et al. (2000) experimentally inoculated plants with arbuscular mycorrhizal fungi and evaluated the effects on aphids, *Myzus persicae*, and butterfly, *Polyommatus icarus*, larvae, respectively. In both studies, mycorrhizal inoculation increased insect growth and survival, apparently related to increased P concentrations in the foliage of mycorrhizal plants. Goverde et al. (2000) further reported that herbivore performance was related to the mycorrhizal species colonizing the host plant. Sooty molds growing on foliage also may affect palatability for herbivores (Fig. 8.17).

Volatile defenses that are induced by defoliators often attract predators and parasites (e.g., Chamberlain et al. 2001, Kessler and Baldwin 2001, Price 1986, Thaler 1999b, Turlings et al. 1990, 1993, 1995). At the same time, however, plant defenses that are sequestered by herbivores also affect herbivore–predator and herbivore–pathogen interactions (L. Brower et al. 1968, Stamp et al. 1997, Tallamy et al. 1998, Traugott and Stamp 1996). Predation on pollinators affects pollinator–plant interactions (Knight et al. 2005b, Louda 1982).



**FIG. 8.16** Effects of methyl jasmonate (MeJA, top) and salicylic acid (SA, bottom) on mortality of fourth instar *Helicoverpa zea* exposed to 1 µg g<sup>-1</sup> aflatoxin B1 (AFB1) after 8 da. Caterpillars were reared on diets containing either 0.2% DMSO (control), MeJA (100 µg g<sup>-1</sup> H-MeJA or 2.9 µg g<sup>-1</sup> L-MeJA), SA (1 mg g<sup>-1</sup> H-SA or 12 mg g<sup>-1</sup> L-SA), 1 µg g<sup>-1</sup> AFB1, MeJA (H-MeJA or L-MeJA) + 1 µg g<sup>-1</sup> AFB1, or SA (H-SA or L-SA) + 1 µg g<sup>-1</sup> AFB1. Values are means and standard errors for three replicates with 20 caterpillars per treatment. Significant differences among treatments in a group are designated by different letters above bars. From Zeng et al. (2009) with permission from the authors and from Springer Science + Business Media.



**FIG. 8.17** Indirect effects of associated species. The light-colored foliage at the ends of shoots is new grand fir, *Abies grandis*, foliage produced during 1994, a dry year, in western Washington; the blackened 1993 foliage was colonized by sooty mold during a wet year; foliage prior to 1993 was produced during extended drought. Sooty mold exploits moist conditions, especially honeydew accumulations and, in turn, may affect foliage quality for folivores.

Herbivores feeding above ground frequently deplete root resources, through compensatory translocation, and negatively affect root-feeding herbivores (e.g., Masters et al. 1993, Rodgers et al. 1995, Salt et al. 1996).

Chilcutt and Tabashnik (1997) examined the effect of diamondback moth, *Plutella xylostella*, resistance to *Bacillus thuringiensis* on within-host interactions between the pathogen and the parasitoid wasp, *Cotesia plutellae*. Resistant caterpillars reduced the success of both pathogen and parasitoid. In susceptible caterpillars, by contrast, the pathogen had a significant, negative effect on the parasitoid, but the parasitoid had no effect on the pathogen. In moderately resistant hosts, competition between the pathogen and parasitoid was symmetrical: each had a significant negative effect on the other. Highly resistant hosts provided a refuge from competition for the parasitoid.

Ants attracted to domatia, to floral or extrafloral nectaries, or to aphid honeydew commonly affect herbivore–plant interactions (Cushman and Addicott 1991, Fritz 1983, Jolivet 1996, Oliveira and Brandão 1991, Tilman 1978). The strength of this interaction varies inversely with distance from ant nests. Tilman (1978) reported that visits by ants to extrafloral nectaries declined with the distance between cherry trees and ant nests. The associated predation on tent caterpillars by nectar-foraging ants also declined with distance from the ant nest.

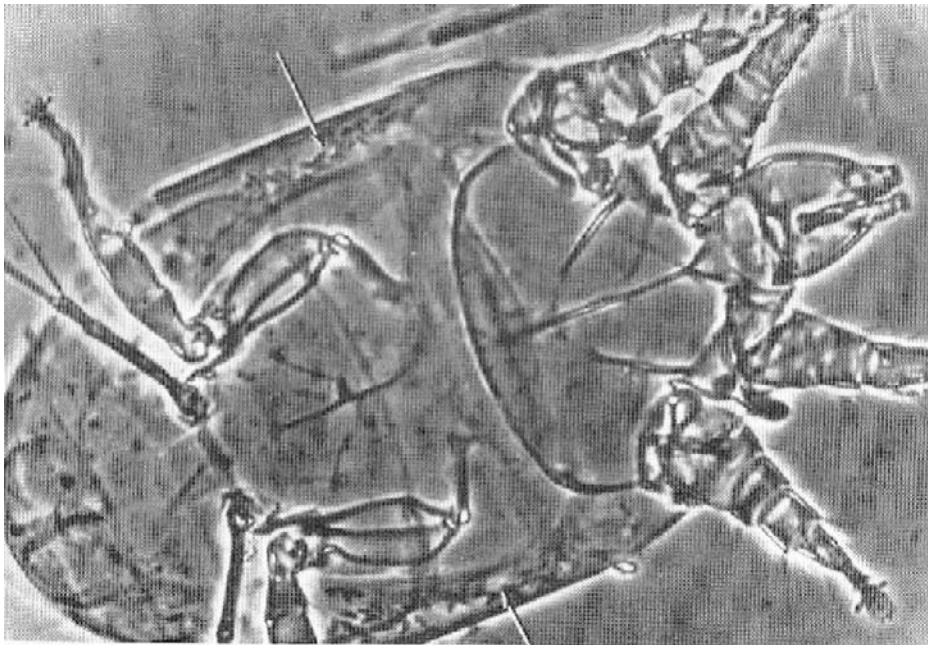
C. Currie (2001) and C. Currie et al. (1999a, b) reported complex interactions between fungus-growing ants (especially leaf-cutting species of *Atta* and *Acromyrmex*) their mutualistic fungi, *Leucocoprinus* spp. and *Leucoagaricus* spp., and associated microorganisms. The ants provide live or dead vegetable material for fungal decomposition, tend the gardens by weeding alien microbes, and feed on the fungus. Foundress queens carry fungus inoculum to establish new colonies. However, fungus gardens often host a virulent fungal pathogen, *Escovopsis*, that is capable of destroying both the fungus garden and the dependent ant colony. The ants have an additional mutualistic association with an actinomycete bacterium that produces specialized antibiotics with potent inhibitory activity against *Escovopsis*.

Complex interactions among a community of invertebrates and fungi affect bark beetle interactions with host trees (see above). The southern pine beetle interaction with blue stain fungus was thought at one time to be mutualistic, with beetles providing transport and fungus contributing to tree death and beetle reproduction. However, more recent studies have demonstrated that this beetle can colonize trees in the absence of the fungus (Bridges et al. 1985), that the blue stain fungus is detrimental to beetle development and is avoided by the mining beetles (Barras 1970, Bridges 1983, Bridges and Perry 1985), and that other mycangial fungi are necessary for optimal beetle development (M. Ayres et al. 2000, Bridges and Perry 1985). The blue-stain fungus is associated only indirectly with the beetle. Spores are collected by phoretic tarsonemid mites in specialized sporothecae (Fig. 8.18) (Bridges and Moser 1983, J. Moser 1985). Beetles carrying these mites transport the blue stain fungus significantly more often than do mite-free beetles (Bridges and Moser 1986). The beetle–tree interaction is affected further by phoretic predaceous mites that prey on nematode parasites of the beetle (Kinn 1980). Finally, folivorous insects increase tree susceptibility to colonization by bark beetles (Wallin and Raffa 2001).

The interaction between termites and mutualistic gut symbionts is affected by wood chemistry and associated wood-colonizing fungi. Mankowski et al. (1998) found that termite preferences among combinations of wood and fungal species generally reflected the suitability of the resource for termite gut fauna, as indicated by changes in gut faunal densities when termites were forced to feed on particular wood–fungus combinations.

Competitive interactions between a pair of species may be modified by the presence of additional competitors or predators. Pianka (1981) proposed a model in which two species with modest competitive overlap over a range of resource values could become “competitive mutualists” with respect to a third species that would compete more strongly for intermediate resource values. The two species benefit each other by excluding the third species from both sides of its resource spectrum (niche). A predator that preys indiscriminately on competing prey species, as they are encountered, will prevent the most abundant prey species from competitively suppressing others. R. Paine (1966, 1969a, b) introduced the term **keystone species** for top predators that maintain balanced populations of competing prey species. However, this term has become used more broadly to include any species with a disproportionate effect on the structure or function of a community and/or ecosystem, based on its abundance (Bond 1993, Power et al. 1996). Herbivorous insects that selectively reduce the density of abundant host species, and thereby balance the abundances of host and non-host plants (Louda et al. 1990a, Schowalter and Lowman 1999) and their associated species, function in a keystone capacity.

Herbivore behavior can be affected by the presence of predators to a greater extent than the actual rate of predation (M.L. Johnson et al. 2006). Predators can be distracted by alternate prey that are less suitable. Meisner et al. (2007) evaluated the effect of



**FIG. 8.18** Ascospores of *Ceratocystis minor* in sporothecae (arrows) formed by tergite 1 on the ventral-lateral sides of a *Tarsonemus ips* female, phoretic on the southern pine beetle, *Dendroctonus frontalis*. Reprinted from Transactions of the British Mycological Society 84, J. Moser, Use of sporothecae by phoretic *Tarsonemus* mites to transport ascospores of coniferous bluestain fungi, Figure 2, Page 752, copyright 1985, with permission from Elsevier.

the spotted alfalfa aphid, *Therioaphis maculata*, on two parasitoids, the native *Praon pequodorum* and the introduced *Aphidius ervi*, of the pea aphid, *Acyrtosiphum pisum*. The spotted alfalfa aphid had a greater distraction effect on the more common *A. ervi*, thereby contributing to persistence of *P. pequodorum* in this system. Furthermore, intraguild predation or competition affects predator foraging activity (e.g., Finke and Denno 2002, 2006, Schmitz 2007).

Although it often is convenient to emphasize the adaptive aspects of species interactions, especially symbiotic interactions, extant associations do not always represent co-evolved relationships. Connell (1980) noted that niche partitioning and other adaptations which minimize competition among living species may reflect competition among their ancestors. Janzen and Martin (1982) suggested that modern seed dispersing animals may have replaced extinct species with which plants co-evolved mutualistic associations in the past. For example, the large-seeded fruits of some plants in North and South America probably reflect adaptation for dispersal by extinct gomphotheres and ground sloths; the smaller extant vertebrates are less capable of transporting such seeds over the distances that are necessary for adequate dispersal.

### III. CONSEQUENCES OF INTERACTIONS

Each species interacts with many others in a variety of ways (competing for various food, habitat and other resources, preying, or being preyed, on, and cooperating with mutualists),

with varying degrees of positive and negative feedback on abundance. Therefore, the population status of each species represents the net effects of these feedbacks.

### A. Population Regulation

As discussed in [Chapter 6](#), competition and predation have been recognized as the two primary mechanisms, along with resource quality and quantity, for limiting population growth of a given species (e.g., May 1983). A particular species typically interacts with at least 2–5 other species as prey (see [Chapter 9](#)) and with additional species as a competitor. Life table analysis often is used to identify key factors that contribute most to population change, but a combination of interactions provides for “redundant” control of population growth.

As noted above, mutualistic interactions may reduce the probability that either species will decline to extinction. Mutualistic species often are closely associated, especially in obligate relationships, and enhance each other’s resource acquisition, energy and nutrient balance, or reproduction. Although mutualism is likely to become unstable at low population densities of either partner, depending on the degree of obligation (May 1983), it could maintain the populations above extinction thresholds (Dean 1983).

The combination of various interactions that involve a particular species should maintain its population levels within a narrower range than would occur if fewer interactions existed. Croft and Slone (1997) found that three predaceous mite species maintained populations of the European red mite, *Panonychus ulmi*, at lower equilibrium levels than did fewer predator species. However, few studies have documented the importance of species diversity or food web structure to stability of population levels.

### B. Community Regulation

The extent to which the network of regulatory interactions maintains stable community structure (see [Chapters 9 and 10](#)) has been a topic of considerable debate. Although some irruptive species show a wide amplitude in population size over time and space, such irruptions often reflect disruption of normal interactions as a result of anthropogenic habitat alteration or introduction into new habitats (see [Chapters 6 and 7](#)). The range in population size may be narrower, and the duration of deviations shorter, in natural ecosystems with intact regulatory interactions.

The capacity for the network of interactions to stabilize species populations may be enhanced by compensatory interactions and changes in the nature or strength of interaction as environmental conditions change. For example, the plant species at a site can, at the same time, compete for resources, share nutrients via mycorrhizae, be growth-limited by herbivores, and limit herbivore populations through the mingling of attractive host odors and repellent (or unattractive) non-host odors (E. Allen and Allen 1990, A. Hunter and Arssen 1988, Visser 1986). The net result of negative and positive feedbacks may be balanced co-existence (W. Carson and Root 2000). Ants maximize energy gain by preying on aphids when the value of honeydew rewards is low (e.g., aphids are present as scattered individuals or individuals dispersing from dense colonies) and by tending aphids when the value of honeydew rewards is high (Bristow 1991, Cushman and Addicott 1991). Competitive interactions could become mutualistic if a third, more competitive, species can be excluded (Pianka 1981). Predation can be neutral or beneficial at low rates and become increasingly negative at higher rates (see [Chapters 12 and 15](#)), thereby stabilizing host populations at intermediate size. Such flexibility in species interactions may facilitate

regulation in a variable environment. Stabilization of community structure has substantial implications for the stability of ecosystem processes (see Chapter 15).

Interactions strongly affect energy or nutrient balances, survival and reproduction of the associated species and therefore represent major selective factors. Strongly negative interactions should select for adaptive responses that minimize the negative effect, e.g., niche partitioning among competitors, prey defenses, etc. Therefore, negative interactions should evolve toward more neutral or mutualistic interactions (G. Carroll 1988, Price 1997).

#### IV. SUMMARY

Species interact in a variety of ways with the other species that co-occur at a site. These interactions produce combinations of positive, neutral, or negative effects for species pairs. However, other species may alter the nature or strength of particular pairwise interactions, e.g., predators can reduce the intensity of competition among prey species by maintaining their populations below levels that induce competition.

Some species compete for a shared resource, with the result that the per capita share of the resource is reduced. This interaction has negative effects on both species. Competition can be by exploitation, when all individuals have equal access to the resource, or interference, when individuals of one species pre-empt use of, or defend, the resource. In cases of asymmetric competition, the superior competitor can exclude inferior competitors over a period of time (competitive exclusion), unless the inferior competitor can escape through dispersal or survival in refuges where superior competitors are absent.

Predator–prey interactions involve a predator killing and eating prey and, therefore, have a positive effect on the predator but a negative effect on the prey. Predators and parasites affect prey populations similarly, but predators generally are opportunistic with respect to prey taxa and kill multiple prey per individual, whereas parasites generally are more specialized for association with a particular host species and may or may not kill the host. Predators show preferences for prey size or defensive capability that maximize capture and utilization efficiency.

Symbiosis involves an intimate association between a symbiont and its host species, which often has co-evolved to maximize the probability of association and to mitigate any host defense against the symbiont. Symbiosis includes parasitism, commensalism, and mutualism. Parasitism is beneficial to the parasite but detrimental to its host. Although parasitism typically is considered to involve animal hosts, insect herbivores have a largely parasitic association with their host plants. Parasitoidism is unique to insects and involves an adult female ovipositing on or in a living host, with her offspring feeding on and eventually killing the host. Most hosts of parasitoids are other arthropods, but at least one sarcophagid fly is a parasitoid of tropical lizards. Commensalism benefits the symbiont but has neutral effects for the host. Typically the symbiont uses the host or its products as a habitat or as a means of transport, with negligible effects on the host. Mutualism benefits both partners and is exemplified by pollinator–plant, ant–plant, ant–aphid, and detritivore–fungus interactions.

A variety of factors influence the nature and intensity of an interaction. Abiotic factors that affect the activity or condition of individuals of a species may alter their competitive, predatory or defensive ability. Resource availability, particularly the quality and patchiness of resources, may mitigate or exacerbate competition or predation by limiting the likelihood that competitors, or predators and their prey, co-occur in time and space. Other species can influence pairwise interactions indirectly. For example, predators often reduce



populations of various prey species below sizes that would induce competition. Induced plant responses can influence predator–herbivore interactions and competition among herbivores in time and space. Species whose presence significantly affects diversity or community structure have been considered keystone species. A number of insect species function in this way.

Competition and predation/parasitism have been recognized as important mechanisms of population regulation and have been amenable to mathematical modeling. Mutualism has been viewed largely as a curiosity, rather than an important regulatory interaction, and modeling efforts have been more limited. However, mutualism may promote both populations and reduce their risk of declining to unstable levels. The network of interactions that affects a particular species may maintain its population size within a narrower range, with less frequent irruptions, than occurs when populations are released from their regulatory network. The extent of mutual regulation (stabilization) of populations through this network of interactions has been widely debated, but has significant implications for the stability of community structure and ecosystem processes governed by these interactions.

# Community Structure

## I. Approaches to Describing Communities

- A. *Species Diversity*
- B. *Species Interactions*
- C. *Functional Organization*

## II. Patterns of Community Structure

- A. *Global Patterns*
- B. *Biome and Landscape Patterns*

## III. Determinants of Community Structure

- A. *Habitat Area and Complexity*
- B. *Habitat Stability*
- C. *Habitat or Resource Conditions*
- D. *Species Interactions*

## IV. Summary

### Streams as a string of habitat types

Streams represent a relatively simple linear continuum of habitat types (patches) progressing from high-gradient headwater sections with narrow channels, high flow rates, rocky beds and abundant coarse woody debris to low-gradient floodplains with wide channels, low flow rates, beds composed of fine sediments, and fine suspended organic matter (Vannote et al. 1980). Patches are distinguished by their substrate, flow rate, water temperature and surrounding terrestrial vegetation. Different patch types support distinct aquatic communities. Headwater patches support more gatherers and shredders (particularly Trichoptera, Plecoptera and Ephemeroptera) of largely unfragmented detritus from overtopping vegetation; pools and lower-elevation patches support more scrapers and filter-feeders (particularly Diptera) that collect fine suspended or deposited organic matter (Hurn and Wallace 1987).

The aquatic communities that characterize the continuum of patch types are interconnected with each other and with adjoining riparian patches by the direction of water flow, detritus and amphibious organisms (Baxter et al. 2005). Dislodged aquatic invertebrates drift downstream and colonize downstream patches or become prey for fish or other aquatic predators. Allochthonous invertebrates and detritus fall or wash in from adjoining riparian patches and fuel the stream ecosystem (J. Allan et al. 2003, Baxter et al. 2005, S. Eggert and Wallace 2003, Wipfli and Musslewhite 2004). Aquatic insect adults emerge and move upstream and over intervening terrestrial landscapes to colonize new pools and riffles (Baxter et al. 2005). Anadromous species move nutrients back upstream to spawning sites (Kikkert et al. 2009, J. Walter et al. 2006). Terrestrial predators and floods transport material from aquatic to terrestrial pools.

(cont.)

Storms raise water level and flow rate, altering channel morphology, washing in terrestrial debris, tumbling stones, moving boulders and logs, dislodging aquatic invertebrates, and depositing fine sediments and nutrients in the floodplain. Terrestrial disturbances change riparian vegetation structure, altering insolation, soil water retention, sedimentation, and the abundance and composition of terrestrial inputs to the stream (J. Allan et al. 2003). Severe disturbances that change stream geomorphology and detrital structure also alter the distribution of substrate and resource patches on which aquatic communities can develop. The characteristic sequence of invertebrate communities may redevelop on the new continuum of patch types or remain in flux, depending on the frequency of the disturbance (Reice 1985). Artificial dams may disrupt processes that link upstream and downstream communities and ensure adequate dispersal and recolonization (Kikkert et al. 2009, Pringle 1997, Pringle et al. 2000).

## INTRODUCTION

A COMMUNITY IS COMPOSED OF ALL THE ORGANISMS OCCUPYING A SITE. The extent to which these organisms are co-evolved to form a consistent and recurring integrated community, or simply represent ad hoc assemblages of loosely interacting species, remains a topic of much discussion. Considerable research has been directed towards identifying spatial and temporal patterns in community structure and evaluating the factors which determine community composition. Such efforts have become increasingly important to conservation efforts, with recognition that many species depend on the presence of associated species. However, comparison of community structures within, or among, broadly distributed community types that share few, if any, species requires approaches that are independent of the taxonomic composition of the community.

Ecologists have developed a variety of non-taxonomic approaches to describing community structure, which provide different types of information to meet different objectives. The diversity of approaches has hindered the comparison of communities that have been described in different terms. Nevertheless, distinct geographic patterns can be seen in community structure, and some community types characterize particular habitat conditions. A number of factors determine community composition, distribution, and dynamics. This chapter focuses on approaches to describing community structure, and on biogeographic patterns and underlying factors which contribute to community structure. Temporal patterns in community structure are the focus of the next chapter.

## I. APPROACHES TO DESCRIBING COMMUNITIES

Although the community is understood to include all organisms at a site, few studies have attempted to describe entire communities. For example, Basset et al. (2007) described an intensive project in Panama that surveyed arthropods in 12 tropical rainforest plots from the ground to the upper canopy using a variety of canopy access techniques and 14 sampling methods for focal groups in soil, litter, understory, and mid- and upper-canopy habitats. Approximately 500,000 arthropods belonging to about 5500 species have been collected from 9400 samples and 315 plant species.

As a result of such diversity, most studies have been limited to subsets of the community (but these subsets have been described as the “plant community”, “arthropod community”, “bird community”), or communities associated with different plant species, tritrophic interactions, etc., although these subsets are more appropriately “assemblages” or component communities. Insects have been addressed to varying degrees in studies of

communities, although insects represent the majority of species in terrestrial and freshwater aquatic communities (Table 9.1) and clearly are integral to community structure and dynamics, e.g., as pollinators, herbivores and detritivores, as resources for vertebrate predators, etc.

Three general approaches to describing community structure can be identified: species diversity, species interactions, and functional organization. Although the “ideal” approach is a topic of intense ecological debate (e.g., Polis 1991a), each approach provides useful information. The final choice primarily reflects the objectives and practical considerations of the project in hand. Where possible, a combination of approaches can yield a broader description of the community.

## A. Species Diversity

Species diversity is a central theme in ecology (Hutchinson 1959). An enormous amount of research has addressed how diversity develops under different environmental conditions, how anthropogenic changes are affecting diversity, and how diversity affects the stability of natural communities and ecosystems (see Chapters 10 and 15). Global diversity of arthropods currently is estimated at 4–6 million species, with most species in the tropics (Novotny et al. 2002). In most ecosystems where the diversity of insect or arthropod species has been inventoried, along with plants and vertebrates, arthropods account for 70–90% of the total number of recorded species (Table 9.1), roughly the same proportion as the total number of described species of organisms. Given that plant and vertebrate inventories are relatively complete, whereas currently described insect species represent only a fraction of the estimated total number of species (May 1988, Sharkey 2001, E. Wilson 1992), the proportional representation of invertebrates probably will increase. Clearly, the measurement of insect diversity is fundamental to understanding patterns of diversity among ecosystems, how this diversity is affected by environmental changes and how diversity affects community and ecosystem development and stability.

Diversity can be represented in various ways (Magurran 2004). The simplest representation is a catalog of species, or the total number of species (richness), a measure that indicates the variety of species in a community ( $\alpha$  diversity). Rarely can all species be detected and documented. Typically, the number of species recorded increases with the number of samples collected. The total number of species can be estimated by extrapolating from a species abundance curve that plots cumulative species against cumulative sample number or area. Alternatively, several parametric and non-parametric estimators can be used (Magurran 2004). Species richness can be standardized for various ecosystems by measuring the number of species per unit area or per 1000 individuals. This measure of diversity accounts for the typical increase in number of species with increasing sample area or number of individuals.

Species richness for many plant and animal groups increases from high latitudes to lower latitudes and from smaller, more isolated islands to larger islands near continents (R. Dunn et al. 2009, MacArthur and Wilson 1967, Magurran 2004, Stiling 1996). Richness also increases from harsh or frequently-disturbed ecosystems, that restrict richness, to more productive ecosystems, that provide a greater number of niches, but typically declines again in very productive ecosystems (Tilman and Pacala 1993). Species diversity appears generally to peak at intermediate levels of disturbance (the **Intermediate Disturbance Hypothesis**) due to a combination of sufficient resources and insufficient time for competitive exclusion (Connell 1978, Huston 1979, Lubchenco 1978, Pickett and White 1985,

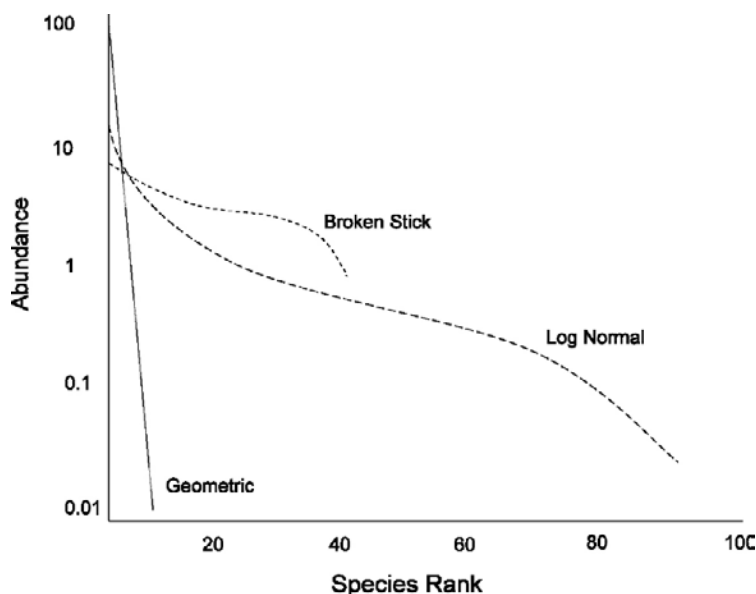
**TABLE 9.1** Numbers of species of vascular plants, vertebrates and arthropods in desert, grassland, forest and marshland ecosystems.

Ecosystem	Vascular Plants	Vertebrates	Arthropods	% Arthropods	Source
Desert					
USSR	125	198	>1360	75	Polis (1991b)
Southwestern U.S.1	174	145	>1100	77	Polis (1991b)
Southwestern U.S.2	>600	201	>2640	77	Polis (1991b)
Grassland/Savanna					
Hungary	1311	347	8496	93	Mahunka (1986, 1987) Szujko-Lacza and Kovacs (1993)
Hungary	1762	289	7095	78	Mahunka (1981, 1983) Szujko-Lacza (1982)
Central U.S.	521	355	>1750 (insects only)	67	Hazlett (1998) Lavigne et al. (1991)
Forest					
Conifer/wetland	536	380	>6500	88	Kaiser (2005), Manville (1942), Procter (1946), Rand and Redfield (1894)
Conifer, western U.S.	600	88	>3500	84	G. Parsons et al. (1991)
Deciduous, eastern U.S.	2816	450	>4300	57	Sharkey (2001)
Tropical, Puerto Rico	470	78	>1500	73	Garrison and Willig (1996), W. Lawrence (1996), Reagan et al. (1996)
Marsh					
Hungary	804	118	5332	85	Mahunka (1991)
Stream					
Tropical, Puerto Rico	0	7	50	88	Covich and McDowell (1996)
Lake					
Balaton, Hungary	>9	51	>1200	95	Benedek (1988)

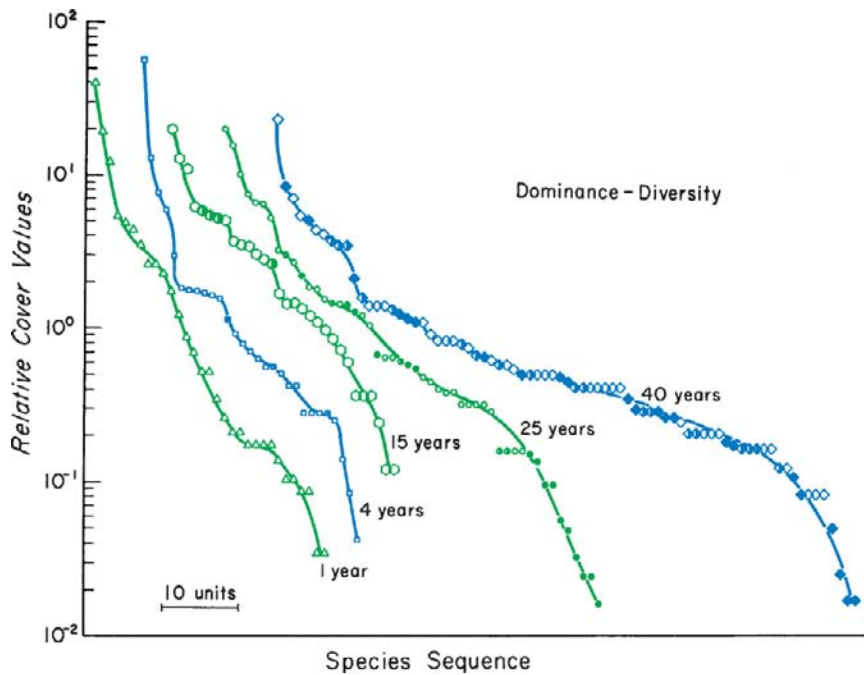
Sousa 1979). Insect diversity may reflect primarily the diversity of plants, which affects diversity of host resources and habitat structure (Curry 1994, Lewinsohn and Roslin 2008, Magurran 2004, Novotný et al. 2006, Stiling 1996).

The various species in a community are not equally abundant. Typically, a few species are abundant, and many others are represented by only one or a few individuals. The distribution of numbers of individuals among species (evenness) is one measure of each species' importance. Rank-abundance curves are a commonly used method of presenting species abundance data (Magurran 2004). Three rank-abundance patterns are most commonly used for comparison among different communities (Fig. 9.1). The **geometric model** (or **niche-pre-emption hypothesis**) describes a community in which successively less-abundant species use the same proportion of resources available after pre-emption by the more abundant species. This situation is predicted to occur when species arrive in an unsaturated community at regular time intervals and exploit a fraction of the remaining resources. The **log normal model** has been shown to be widely applicable, because this distribution results mathematically from random variation among a large number of factors producing a normal distribution. In natural communities, the large number of environmental factors that affect species abundances fulfils this condition. This condition can also be met by increasing numbers of species randomly partitioning available niches. The **broken stick model** reflects relatively uniform use of resources among species in the community. Generally, as richness and evenness increase, the rank-abundance pattern shifts from a geometric pattern to a log normal pattern and finally to a broken stick pattern. Disturbances and other environmental changes can alter rank-abundance patterns (Figs. 9.2 and 9.3) (Bazzaz 1975, Kempton 1979).

Richness and evenness have been combined mathematically in various ways to calculate diversity indices based on proportional abundances of species (e.g., Magurran 2004, Stiling 1996). Two indices have been used widely, the **Shannon–Wiener**, or Shannon



**FIG. 9.1** Typical shapes of three rank-abundance models. Species are ranked from most to least abundant. Redrawn from Magurran (2004) with permission from John Wiley & Sons.



**FIG. 9.2** Rank-abundance curves for old fields representing five post-abandonment ages in southern Illinois. Open symbols are herbs, half-open symbols are shrubs and closed symbols are trees. From Bazzaz (1975) permission from the Ecological Society of America.

(often incorrectly referred to as the Shannon–Weaver) index, and **Simpson’s** index. The two indices differ in their emphasis on species richness (Shannon–Wiener) or abundance (Simpson’s).

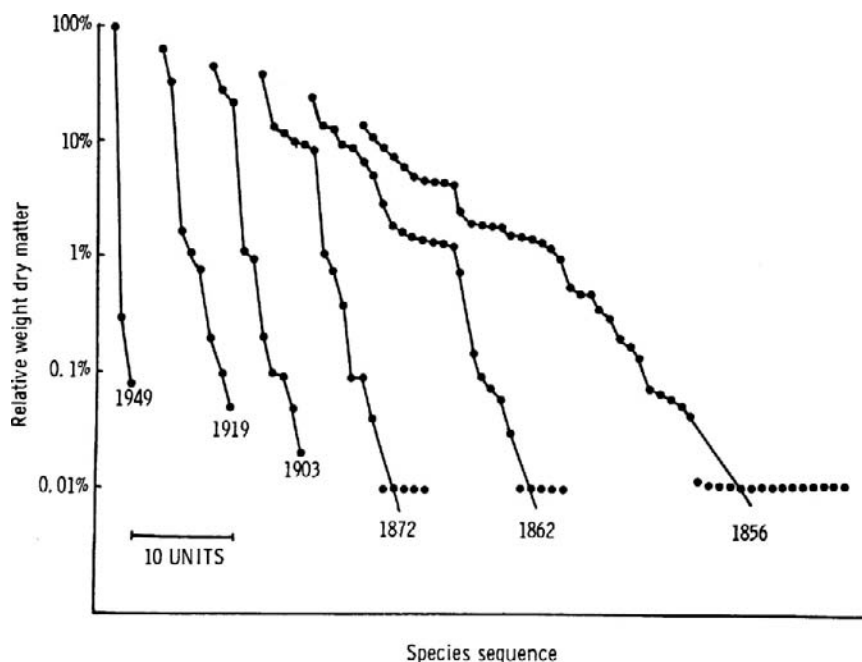
The Shannon–Wiener index assumes that individuals are randomly sampled from an effectively infinite population and that all species are represented in the sample. Diversity ( $H'$ ) is calculated as:

$$H' = -\sum_{i=1}^n p_i \ln p_i \quad (9.1)$$

where  $p_i$  is the proportion of individuals found in the  $i$ th species. Values generally fall in the range 1.5–3.5, rarely surpassing 4.5. If the rank-abundance pattern follows a log normal model,  $10^5$  species are necessary to produce a value of  $H' > 5$ . If the index is calculated for a number of samples, the indices will be normally distributed and amenable to the use of parametric statistics, including ANOVA, to compare diversities among sets of samples (Margurran 2004), e.g., to evaluate the effects of ecosystem change (Fukami et al. 2001). If all species were equally abundant, a maximum diversity ( $H'_{\max}$ ) can be calculated as  $\ln S$ , where  $S$  is the total number of species. The ratio of observed to maximum diversity is a measure of evenness.

When randomness cannot be assured (e.g., data from light trapping, where species representation is based on differential attraction to light), the **Brillouin** index is a more appropriate measure of diversity (Margurran 2004). This index ( $HB$ ) is calculated as:

$$HB = (\ln N! - \sum \ln n_i!) / N \quad (9.2)$$



**FIG. 9.3** Change over time in rank abundance of plant species in an experimental plot of permanent pasture at Rothamsted, U.K. following continuous application of nitrogen fertilizer since 1856. Species with abundances  $< 0.01\%$  were recorded as  $0.01\%$ . From Kempton (1979) with permission from John Wiley & Sons.

where  $N$  is the total number of individuals, and  $n_i$  is the number of individuals in the  $i$ th species. Values of this index rarely exceed 4.5 and generally are correlated with, but lower than, Shannon indices for the same data.

Simpson's index differs from the Shannon–Wiener and Brillouin indices in being weighted toward the abundances of the most common species, rather than species richness (Magurran 2004). This index ( $D$ ) is calculated as:

$$D = \sum_{i=1}^n (n_i(n_i - 1)) / (N(N - 1)) \quad (9.3)$$

where  $n_i$  is the number of individuals in the  $i$ th species, and  $N$  is the total number of individuals. Diversity decreases as  $D$  increases, so Simpson's index generally is expressed as  $1 - D$  or  $1/D$ . Once the number of species exceeds 10, the underlying rank-abundance pattern is important in determining the value of  $D$ .

Diversity indices have been a tool for comparing taxonomically distinct communities, based on their rank-abundance patterns. However, important information is lost when species diversities are reduced to an index (Magurran 2004). For example, a larger diversity index can reflect the influence of increased abundances of invasive or exotic species without conveying important information about the change in community integrity or function. Very different community structures can produce the same diversity index. Furthermore, ecologically unique communities are not necessarily diverse and would be lost if conservation decisions were made on the basis of diversity alone (Magurran 2004).



The large number of species represented by single individuals (“singletons”) poses a dilemma (Novotný and Basset 2000). Should these be included in diversity calculations, or not? Their presence may be accidental or may reflect inadequate or biased sampling. Novotný and Basset (2000) found that singletons consistently represented 45% of herbivores sampled among plant species. Some represented species that were more common on other plant species, whereas others represented species that were relatively rare on numerous host plants. Novotný and Basset (2000) concluded that singletons are an important component of communities and should not be excluded from community studies as an artifact or a group of negligible importance.

Diversity also can be measured as the variation in species composition among communities or areas ( $\beta$  diversity). Several techniques have been developed to compare communities, based on their species compositions and rank-abundance patterns, across environmental gradients or between areas (Magurran 2004).

The simplest of these similarity measures are indices based on species presence or absence in the communities being compared. The **Jaccard** index ( $C_j$ ) is calculated as:

$$C_j = j/(a + b - j) \quad (9.4)$$

and the **Sorenson** index ( $C_s$ ) as:

$$C_s = 2j/(a + b) \quad (9.5)$$

where  $j$  is the number of species found in both sites,  $a$  is the number of species in the first site, and  $b$  is the number of species in the second site. Neither of these indices accounts for species abundances.

Three quantitative similarity indices have been used widely. A modified version of the Sorenson index ( $C_N$ ) is calculated as:

$$C_N = 2jN/(aN + bN) \quad (9.6)$$

where  $jN$  is the sum of the lower of the two abundances for each species found in both sites,  $aN$  is the total number of individuals in the first site, and  $bN$  is the total number of individuals in the second site. Most quantitative similarity indices are influenced strongly by species richness and sample size. The **Morisita–Horn** index ( $C_{mH}$ ) is influenced less by species richness and sample size, but is sensitive to the abundance of the dominant species. Nevertheless, it may be generally a satisfactory similarity index (Magurran 2004). This index is calculated as:

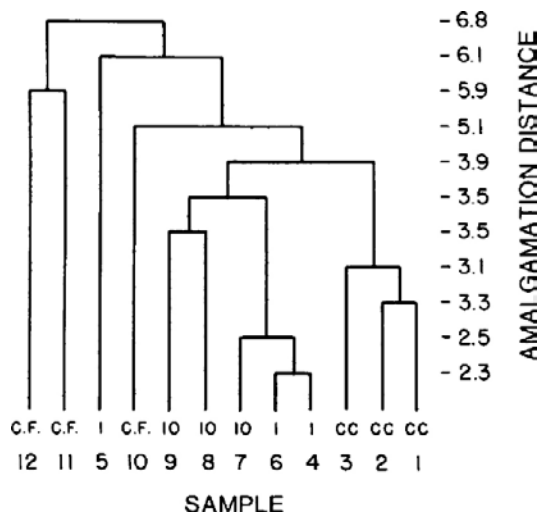
$$C_{mH} = 2\sum(an_i bn_i)/(da+db)aN \times bN \quad (9.7)$$

where  $aN$  is the total number of individuals in the first site,  $an_i$  is the number of individuals of the  $i$ th species in the first site, and  $da = \sum an_i^2/aN^2$ . The **Bray–Curtis Similarity** index also has been shown to be effective and robust (Minchin 1987). This index is calculated as:

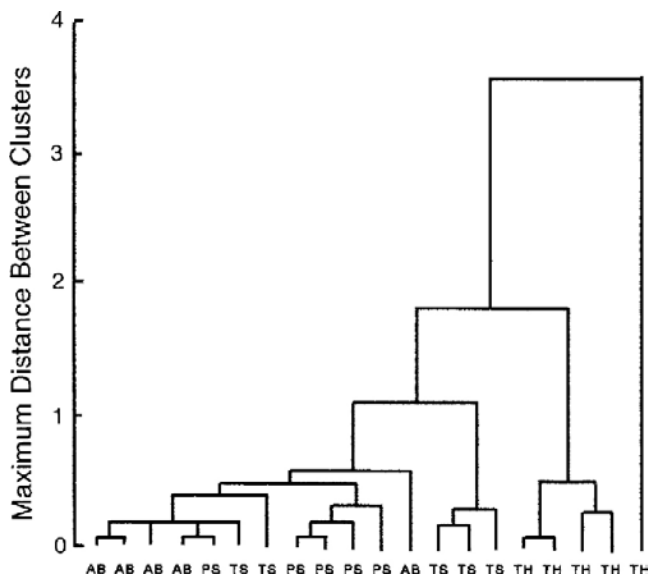
$$C_B = \left( 1 - \frac{\sum_{i=1}^n |X_{ij} - X_{ik}|}{\sum_{i=1}^n (X_{ij} + X_{ik})} \right) \quad (9.8)$$

where  $n$  is the number of species, and  $X_{ij}$  and  $X_{ik}$  are the number of individuals of the  $i$ th species at sites  $j$  and  $k$ , respectively (Cartron et al. 2003).

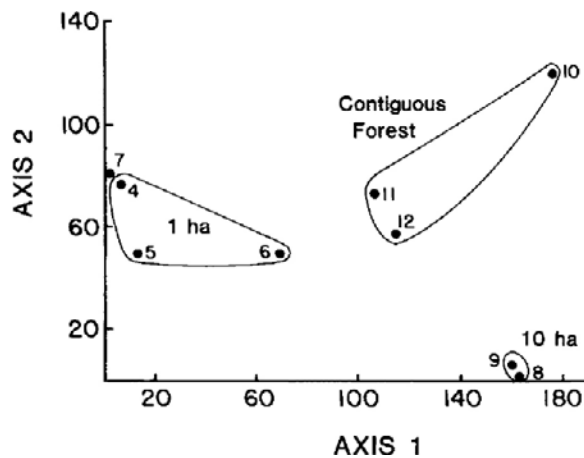
More recently, multivariate statistical techniques have been applied to the comparison of communities. **Cluster analysis** can be performed using either presence–absence or quantitative data. Each pair of sites is evaluated on the degree of similarity, then combined sequentially into clusters to form a dendrogram with the branching point representing the



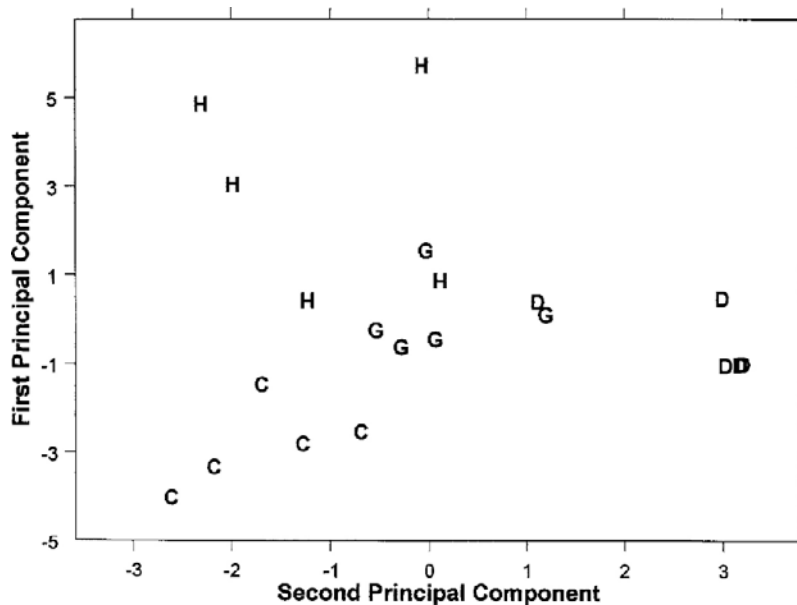
**FIG. 9.4** Dendrogram of similarity for dung beetles in clearcuts (CC), 1 ha (1) and 10 ha (10) forest fragments, and contiguous forest (C.F.). From B. Klein (1989) with permission from the Ecological Society of America.



**FIG. 9.5** Dendrogram of arthropod community similarity in canopies of four old-growth conifer species at the Wind River Canopy Crane Research Facility in southwestern Washington. AB = *Abies grandis* (grand fir), PS = *Pseudotsuga menziesii* (Douglas-fir), TS = *Tsuga heterophylla* (western hemlock), and TH = *Thuja plicata* (western redcedar). Data from Schowalter and Ganio (1998).



**FIG. 9.6** Detrended Correspondence Analysis ordination of dung beetle assemblages in 1 ha and 10 ha forest fragments, and contiguous forest. From B. Klein (1989) by permission from the Ecological Society of America.



**FIG. 9.7** Principle Components Analysis ordination of arthropod communities in canopies of four old-growth conifer species at the Wind River Canopy Crane Research Facility in southwestern Washington. G=grand fir (*Abies grandis*), D=Douglas-fir (*Pseudotsuga menziesii*), H=western hemlock (*Tsuga heterophylla*), and C=western redcedar (*Thuja plicata*). From Schowalter and Ganio (1998) with permission from CAB International, Wallingford, U.K.

measure of similarity (Figs. 9.4 and 9.5). Ordination compares sites on their degree of similarity, then plots them in Euclidian space, with the distance between points representing their degree of similarity (Figs. 9.6 and 9.7). Ordination techniques include **principal components analysis** (PCA), **detrended correspondence analyses** (DCA), and **non-metric multidimensional scaling** (NMS).

Minchin (1987) evaluated several commonly used ordination techniques for sensitivity to sampling pattern, data distribution and geometric distortion. PCA and principle coordinates analysis both suffered from curvilinear distortion, and DCA lacked robustness to variation in sampling pattern and response model. NMS was shown to be the most robust ordination method and has become widely used in ecological studies.

Both cluster and ordination techniques can indicate which species or environmental factors contribute most to the discrimination of groupings. **Indicator species analysis** (Dufrêne and Legendre 1997) is another method which can be used to identify species or groups of species that characterize groups of sites, based on ecological gradients or treatments, by combining the frequency of a species, occurrence in a particular site category and its degree of restriction to that site category. Dufrêne and Legendre (1997) compared this method with clustering and ordination techniques to identify carabid beetle species characterizing combinations of soil moisture and alkalinity represented by 69 sites in Belgium.

The significance of differences among groups of points representing sites, treatments, etc., can be analyzed using **multiple response permutation procedures** (MRPP) (Biondini et al. 1988). This method measures the separation among weighted means of points in *a priori* groups and tests the probability of occurrence of this mean relative to other possible separations with the same size structure that could have occurred for these points (Biondini et al. 1988).

## B. Species Interactions

Communities can be characterized in terms of the relationships among species, which are most commonly trophic (feeding) interactions, i.e., food webs. Clearly, the most complete description of the community would include all possible interactions (including indirect interactions) among the total number of species (e.g., Polis 1991a). In practice, this is difficult to accomplish, even in relatively species-poor communities (Camilo and Willig 1995, Polis 1991a, 1991b, Reagan et al. 1996), because of the largely unmanageable number of arthropod species (Table 9.1) and lack of complete information on their interactions. More commonly, research focuses on subsets or simplified representations of the community.

The simplest approach to description of a community emphasizes interactions between only a few species, e.g., plant–herbivore or predator–prey interactions. In particular, many studies have addressed the relatively distinct assemblages of arthropods which are based on individual plant species (e.g., Richerson and Boldt 1995, Schowalter and Ganio 1998) or soil/litter resources (e.g., J.C. Moore and Hunt 1988, Seastedt et al. 1989). This approach maximizes description of interactions among a manageable number of relatively resource-specific herbivores or detritivores and their associated predators and parasites. Detailed descriptions at this level have been useful for identifying and comparing factors affecting these trophic interactions (e.g., chemical defenses, see Chapters 3 and 8), for evaluating the co-evolutionary patterns of speciation between insects and their hosts (e.g., Becerra 1997), and for comparing trophic interactions among community types, e.g., comparing phenological responses of insect herbivores to leaf emergence in

tropical and temperate forests (Coley and Aide 1991). However, this approach emphasizes relatively linear trophic relationships (i.e., food chains) and does not address linkages among members of different component communities.

Broader subcommunities can be identified. For example, Hunt et al. (1987) described the trophic interactions among arthropod and microbial species comprising the litter subcommunity of a grassland ecosystem. J.C. Moore and Hunt (1988) subsequently noted that relatively discrete component communities, supported by particular resource bases (bacteria, fungi or plant roots), could be distinguished within this broader subcommunity (Table 9.2). Similarly, individual plant species represent resource bases for relatively discrete component communities of associated arthropods and other organisms in the above-ground subcommunity (Curry 1994). Resource-based component communities are linked to each other by generalist herbivores and predators. The canopy and soil/litter subcommunities are linked by species that feed above-ground but pupate in the soil, or that feed on litter resources but disperse and bask on foliage, and by predators and detritivores that move among substrates in search of resources.

The most inclusive approach to community description is represented by interaction webs, in which all species are connected by arrows which indicate interactions. Relatively

**TABLE 9.2** The proportion of energy and nitrogen derived from the bacterial, fungal and root (including mycorrhizal fungi) resource channels by different faunal groups in the North American shortgrass steppe.

Faunal Group	Resource Channel		
	Bacteria	Fungi	Roots
Protozoa			
Flagellates	100	0	0
Amoebae	100	0	0
Ciliates	100	0	0
Nematodes			
Bacteriovores	100	0	0
Fungivores	0	90	10
Root-feeders	0	0	100
Omnivores	100	0	0
Predators	69	3	28
Microarthropods			
Mycophagous Collembola	0	90	10
Mycophagous oribatid mites	0	90	10
Mycophagous prostigmatid mites	0	90	10
Nematophagous mites	67	4	30
Predaceous mites	40	39	21

From J. Moore and Hunt (1988) by permission from Nature, © 1988 Macmillan Magazines, Ltd.

few communities are composed of sufficiently few species to depict all interactions conveniently. Hot springs and other communities that are subject to extreme abiotic conditions typically are composed of a few tolerant algal and invertebrate species (N.C. Collins et al. 1976). Communities composed of relatively few invertebrate and vertebrate species characterize some aquatic ecosystems, e.g., vernal pools, riffles, etc. However, even the desert communities described by Polis (1991a) were composed of  $>10^3$  arthropod species, most of which had not been studied sufficiently to provide complete information on interactions. A number of studies have addressed trophic interactions, i.e., food webs, although even trophic interactions are poorly known for many species, especially insects.

A number of techniques have been used to identify trophic relationships. Early studies of food web structure tracked radioisotopes through trophic exchanges (e.g., Crossley and Howden 1961). Stable isotopes or other tracers also can be tracked through feeding exchange (e.g., Christenson et al. 2002, D. Wise et al. 2006). Furthermore, animal tissues reflect the stable isotope ratios of their diet, with slight enrichment of  $^{15}\text{N}$  with increasing trophic level (Blüthgen et al. 2003, Ponsard and Arditì 2000, Scheu and Falca 2000, Taya-su et al. 1997). However, interpretation of trophic interactions depends on the isotopic homogeneity of the diet (Gannes et al. 1997). Selective feeding on particular substrates can affect  $^{13}\text{C}$  enrichment in animals (Šantrůčková et al. 2000). Adams and Sterner (2000) reported that  $^{15}\text{N}$  enrichment was linearly related to dietary C:N ratio, which could vary sufficiently to indicate as much as a 2-trophic level separation, potentially leading to misidentification of trophic level for particular species.

Advances in molecular techniques have provided new tools for identifying interactions among species in communities. Enzyme-linked immunosorbent assay (ELISA) techniques involve development of antibodies against enzymes from potential food sources. These antibodies can be used to precipitate enzymes in gut samples which contain the target food source. Irby and Apperson (1988) and Savage et al. (1993) used ELISA to identify associations between various mosquito species and their particular amphibian, reptile, bird, and mammal hosts. Agustí et al. (1999a) demonstrated the utility of this technique for detecting prey, *Helicoverpa armigera*, in heteropteran, *Dicyphus tamaninii*, *Macrolophus caliginosus*, and *Orius majusculus* predator gut contents. More recently, polymerase chain reaction (PCR) and DNA amplification techniques have been used to illuminate feeding relationships. Broderick et al. (2004) used this methodology to describe the microbial community in gypsy moth, *Lymantria dispar*, midgut and to demonstrate that the bacterial composition was influenced by the plant species composition of the diet. Agustí et al. (1999b), Y. Chen et al. (2000), Hoogendoorn and Heimpel (2001), and Zaidi et al. (1999) demonstrated that PCR and DNA amplification can be used to identify prey species in gut contents for 12–28 hr after predator feeding. Although these techniques can help to identify feeding relationships, developing the sequence library to distinguish all potential prey in the field presents a challenge.

More recently, S. Hall (2009) described a stoichiometrically-explicit approach to food web modeling. This approach recognizes the importance of imbalances between the nutrient composition that is required by each member of the food web and the nutrient composition actually available in food resources (see Chapter 3). These imbalances shape the effect of consumers on their own resources through nutrient cycling (see Chapters 11–15) and link food web structure to ecosystem function.

Several properties have appeared to characterize food webs (see Briand and Cohen 1984, Cohen and Palka 1990, Cohen et al. 1990, N. Martinez 1992, May 1983, Pimm 1980, 1982, Pimm and Kitching 1987, Pimm and Lawton 1977, 1980, Pimm and Rice 1987, Pimm

et al. 1991, Polis 1991b, Reagan et al. 1996). However, food web analysis typically has been based on the combination of all insects (often all arthropods) into a single category, in contrast to resolution at the individual species level for plants and vertebrates. Polis (1991b) and Reagan et al. (1996) increased the resolution of arthropod diversity to individual “kinds”, based on taxonomy and similar phylogeny or trophic relationships, for evaluation of food web structure in desert and tropical rainforest communities, respectively. They found that the structure of their food webs differed from that of food webs in which the arthropods were combined. Goldwasser and Roughgarden (1997) analyzed the effect of taxonomic resolution on food web structure and found that food web properties reflected the degree of taxonomic resolution. The following proposed properties of food webs, based on analyses with insects or arthropods as a single category, are evaluated with respect to challenges based on greater resolution of arthropod diversity.

### 1. Food Chain Length

Early analyses indicated that the length of food chains within food webs should be relatively short; at most 3–5 links (May 1983, Pimm and Kitching 1987, Pimm and Lawton 1977), because the laws of thermodynamics predict energy limitation at higher trophic levels. Therefore, energy gain should be maximized by feeding lower on the food chain. At the same time, competition for prey is most severe at lower levels, perhaps restricting energy gains. Consequently, the trophic level selected by predators represents a trade-off between maximizing energy availability and minimizing competition. However, Polis (1991b) and Reagan et al. (1996) found chain lengths of 6–19 links, using food webs with greater resolution in arthropod taxonomy. Reagan et al. (1996) reported a mean chain length of 8.6, double the length of chains found when arthropods are combined into a single category. This probably reflects greater efficiency of secondary production among insects, compared to homeothermic organisms (see Chapter 4).

### 2. Trophic Loops and Intraguild Predation

Loops, or reciprocal predation, in which two species feed on each other or a third species feeds on one and is eaten by the other, should be rare or absent because the size range of prey is constrained by physical limits, and because loops potentially reduce population recovery following disturbance (Pimm 1982, Pimm and Rice 1987). Intraguild predation involves predation among members of the same trophic level. Cannibalism is considered a “self-loop” (see Fox 1975a).

Polis (1991b) and Reagan et al. (1996) reported the occurrence of a substantial number of loops, especially involving arthropods. In most cases, each species in the loop preys on juveniles of the other species. For example, in a tropical forest in Puerto Rico, adult centipedes prey on young frogs, whereas adult frogs prey on young centipedes. Polis (1991b) reported that several species of desert ants regularly prey on each other. Other predators constituted 9% of the overall diet of the aquatic heteropteran, *Notonecta hoffmanni*, studied by Fox (1975b). Longer loops involving up to four species have been observed (Reagan et al. 1996). Reagan et al. (1996) found that 35% of 19,800 observed chains (corrected to exclude loops) include at least one species involved in at least one loop.

Intraguild predation appears to be pervasive within arthropod food webs, with frequencies of 58–87% within trophic levels (Arim and Marquet 2004, M.D. Hunter 2009) complicating measurement of food chain length, and explaining irruptions of prey species when multiple predator species are present. However, the extent of intraguild predation is influenced by prey and predator densities, habitat complexity and the particular predator

species involved (Finke and Denno 2006, S. Moser and Obrycki 2009, Schmitz 2007). Furthermore, habitat complexity can reduce intraguild predation by providing refuges for multiple predators (Finke and Denno 2002, 2006).

A number of studies have demonstrated significant reduction in predator abundances as a result of intraguild predation (e.g., Denno et al. 2004, Erbilgin et al. 2004, Finke and Denno 2002, 2006, Mooney 2007, Pérez-Lachaud et al. 2004, Rosenheim 2005, D. Sanders and Platner 2007). Rosenheim (2005) used manipulative experiments to show that the abundance of the anthocorid bug, *Orius tristicolor*, was reduced significantly as a result of intraguild predation by big-eyed bugs, *Geocoris* spp., and lacewing, *Chrysoperla* spp., larvae in cotton fields in California, U.S., interfering with top-down control of spider mite, *Tetranychus* spp., prey.

Spiders and ants commonly compete for prey and also prey on each other (Halaj et al. 1997, D. Sanders and Platner 2007). D. Sanders and Platner (2007) used a factorial experimental design to exclude ants and/or spiders from grassland plots, and then measured changes in the abundances of ants, spiders and other arthropods. Exclusion of either ants or spiders resulted in increased abundance of the other. Ant exclusion increased densities of Lepidoptera larvae, but reduced densities of scale insects. Spider exclusion increased densities of Collembola. Increased <sup>15</sup>N enrichment of adult spiders, relative to juveniles, indicated greater intraguild predation by adults.

### 3. Food Web Connectance

Community connectance, the proportion of potential feeding relationships that actually occur in the community (Pimm 1982), should increase with increasing species richness as:

$$L = 0.14S^2 \quad (9.9)$$

where L is the number of links, and S is the number of species (N. Martinez 1992). This **constant connectivity hypothesis** predicts that, on average, each species will be involved in predator-prey interactions with 14% of the other species in the community. Havens (1992) analyzed 50 pelagic food webs with species richness ranging from 10 to 74 and found that the number of links per species increased 4-fold over this range. Reagan et al. (1996) reported that the food web in a tropical forest in Puerto Rico supported constant connectance at low taxonomic resolution, but that connectance dropped quickly as taxonomic resolution was increased. Polis (1991b) and Reagan et al. (1996) also found that the prediction that each species interacts with only 2–5 other species greatly underestimates the actual number of linkages per species, and concluded that these properties are sensitive to taxonomic resolution.

### 4. Food Web Compartmentalization

Pimm and Lawton (1980) proposed that food webs should be compartmentalized between, but not within, habitats. Whereas the relatively distinct communities that represent disturbed vs. undisturbed patches within an ecosystem represent compartmentalization, the communities within habitat patches should not be compartmentalized. This property largely follows from the constant connectivity hypothesis, i.e., compartmentalization is inconsistent with equal linkage among species.

The vague definition of habitat complicates the assessment of compartmentalization. For example, does soil/litter constitute a habitat or a subunit of the site habitat? Soil/litter subcommunities tend to be relatively distinct from plant-based above-ground subcommunities.



Nevertheless, compartmentalization can be identified within recognized habitats. J.C. Moore and Hunt (1988), Polis (1991b) and Reagan et al. (1996) found distinct compartmentalization within the community of a single patch when arthropod species or “kinds” were distinguished (Table 9.2). Distinct compartmentalization of arthropod assemblages has been shown among plant species (e.g., Fig. 9.7), and even between trees and sapling of the same species (Basset 2001). Compartmentalization reflects the development of component communities composed of specialists feeding on particular resources and the resulting channels of energy and material transfer. Host specificity appears to occur more frequently and at a finer spatial scale among herbivorous and detritivorous arthropods, due to their small size, short life spans, and intricate biochemical interactions (see Chapter 3). These factors facilitate rapid adaptation for utilization of particular resources, which can differ even within individual leaves (e.g., Mopper and Strauss 1998, K. Parsons and de la Cruz 1980). Many parasitoids also are host specific, so that compartmentalization is maintained at higher trophic levels among arthropods. J.C. Moore and Hunt (1988) found that compartmentalized models of food webs were more stable than non-compartmentalized webs.

Generalists at all trophic levels connect compartments and link food webs among habitats. For example, emergent stream insects enter terrestrial food webs, and riparian insects falling into streams enter the aquatic food web (Burdon and Harding 2008, see Fig. 1.4). McCann et al. (2005) employed spatially implicit food web models to demonstrate that highly mobile predators connect food webs, with important effects on food web stability. They argued that mobile predators can stabilize food webs in variable and expansive spatial structures, but destabilize food webs when space is confined and predators more strongly couple local habitats.

### 5. Omnivory

Omnivores (defined as species that feed on more than one trophic level) should be rare (Pimm 1982, Pimm and Rice 1987). Pimm and Rice (1987) concluded that omnivory should reduce the stability of food web interactions. However, as noted above (Section B.2. Trophic Loops and Intraguild Predation), a number of studies have demonstrated intraguild predation (Arim and Marquet 2004, Denno et al. 2004, Erbilgin et al. 2004, M.D. Hunter 2009, Pérez-Lachaud et al. 2004, Rosenheim 2005). Some herbivores or detritivores consume competitors when encountered, and some predators feed on plant materials and other predators, as well as on herbivores (M.D. Hunter 2009). Polis (1991b) and Reagan et al. (1996) reported that omnivory is common in food webs when arthropods are resolved to species or “kinds”. In fact, they found that most species fed at more than one trophic level, often from non-adjacent trophic levels, in desert and tropical rain forest communities.

Fagen (1997) tested the effect of omnivory on the stability of community structure by manipulating the degree of omnivory (by excluding either a specialist predator, the nabid bug, *Nabis alternatus*, or an omnivorous predator, wolf spiders, *Pardosa* spp.) in replicated plots, and then disturbing the community by applying an aphicide to disrupt abundance of the prey, *Macrosiphum valeriani*. Plots with high levels of omnivory showed significantly reduced responses to disturbance by seven of 14 species, compared to plots with low levels of omnivory; no species showed significantly increased responses to disturbance. These data indicated that omnivory increased the stability of food web interactions.

### 6. Ratio of Basal to Top Species

Finally, ratios of species and links from basal to intermediate to top trophic levels (where basal species are prey only, intermediate species are prey and predators, and top predators

have no predators) are expected to be constant (Briand and Cohen 1984). This implies a large proportion of top predators, which are expected to comprise 29% of all species in a given community, and prey to predator ratios should be  $< 1.0$  (Briand and Cohen 1984).

As shown for the properties discussed above, this property reflects poor resolution of arthropod diversity. Top predators appear to be common because they are easily distinguished vertebrate species, whereas poor taxonomic resolution at basal and intermediate levels underrepresents their diversity. Reagan et al. (1996) reported that in a rain forest food web that distinguished “kinds” of arthropods, representation of basal and intermediate species was 30% and 70% of all species, respectively, and the proportion of top predators was  $< 1\%$ . Polis (1991b) also reported that top predators were rare or absent in desert communities. Both Polis (1991b) and Reagan et al. (1996) reported that ratios of prey species to predator species are much greater than 1.0 when the true diversity of lower trophic levels is represented.

Although the properties of food webs identified by early theorists may be flawed, to the extent that arthropod diversity was not resolved adequately, they represent hypotheses that stimulated considerable research into community organization. Future advances in food web theory will reflect efforts to address arthropods at the same level of taxonomic resolution as for other taxa.

### C. Functional Organization

A third approach to community description is based on the guild, or functional group, concept (Cummins 1973, C. Hawkins and MacMahon 1989, Körner 1993, Root 1967, Simberloff and Dayan 1991). The guild concept was originally proposed by Root (1967), who defined a guild as a group of species, regardless of taxonomic affiliation, that exploit the same class of environmental resources in a similar way. This term has been useful for studying potentially co-evolved species that compete for, and partition use of, a common resource. The largely equivalent term, functional group, was proposed by Cummins (1973) to refer to a group of species having a similar ecological function. Insects, as well as other organisms, have been combined into guilds or functional groups based on the similarity of their response to environmental conditions (e.g., Coulson et al. 1986, Fielding and Brusven 1993, Grime 1977, Root 1973) or of effects on resources or ecosystem processes (e.g., Romoser and Stoffolano 1998, Schowalter et al. 1981c, Sipel and de Ruiter-Dijkman 1993). This method of grouping is one basis for pooling “kinds” of organisms, as discussed above.

Pooling species in this way has been attractive for a number of reasons (Root 1967, Simberloff and Dayan 1991). First, it reflects the compartmentalization of natural communities (see above) and focuses attention on sympatric species that share an ecological relationship, e.g., those competing for a resource or affecting a particular ecological process, regardless of taxonomic relationship. Second, it helps resolve the multiple usage of the term “niche” to refer both to the functional role of a species and the set of conditions that determines its presence in the community. Use of guild or functional group to refer to species’ ecological role(s) permits limitation of the term niche to refer to the conditions that determine species presence. Third, this concept facilitates comparative studies of communities which may share no taxa but do share functional groupings, e.g., herbivores, pollinators, detritivores, etc. Guild or functional groupings permit focus on a particular group, with specific functional relationships, among community types. Hence, researchers avoid the necessity of cataloging and studying all species represented in the

community, a nearly impossible task, before comparison is possible. Functional groupings are particularly useful for simplifying ecosystem models to emphasize the effects of functional groups with particular patterns of carbon and nutrient use on fluxes of energy and matter. Nevertheless, this method for describing communities has been used more widely among aquatic ecologists than among terrestrial ecologists.

The designation of functional groupings is largely a matter of convenience and depends on research objectives (e.g., C. Hawkins and MacMahon 1989, Körner 1993, Simberloff and Dayan 1991). For example, defining “the same class of resources” or “in a similar manner” is ambiguous. Each species represents a unique combination of abilities to respond to environmental conditions and to affect ecosystem processes, i.e., species within functional groups are similar only on the basis of the particular criteria used to distinguish the groups. Characterization of functional groups based on effect on primary production, effect on carbon flux, or effect on biogeochemical cycling would involve different combinations of species.

Insects are particularly difficult to categorize because functional roles can change seasonally (e.g., wasps switching between predation and pollination) or during maturation (e.g., sedentary herbivorous larvae becoming mobile pollinating adults, aquatic larvae becoming terrestrial adults, etc.), and many species are too poorly known to have functional roles assigned to them. Nearly all Lepidoptera can be assigned to a plant-feeding functional group, but various species would be assigned to different functional groups on the basis of the plant part(s) affected (e.g., foliage, shoots, or roots). Clearly, functional groups can be subdivided to represent a diversity of resource exploitation strategies or subtle differences in ecological effects. For example, the plant-feeding “functional group” could be divided into subgroups that selectively feed on ruderal, competitive, or stress-adapted plant hosts (Fielding and Brusuen 1995). The foliage-feeder guild can be divided into subgroups that fragment foliage, mine foliage, or suck cellular fluids, feed on different plant species, etc., with each subgroup affecting energy and matter fluxes in a different manner. Luh and Croft (1999) developed a computer algorithm to classify predaceous phytoseiid mite species into functional groups (specialist vs. generalist predators). The computer-generated classification confirmed the importance of the combination of life history traits that had been used previously to distinguish functional groups.

The species included in a particular functional group should not be considered redundant (Beare et al. 1995, Lawton and Brown 1993), but rather complementary, in terms of ensuring ecological functions. Schowalter et al. (1999) reported that each functional group that was defined on the basis of feeding type included species that responded positively, negatively or non-linearly to moisture availability. Species replacement within functional groups maintained functional organization over an experimental moisture gradient, but changes in species would result in differences in pathways and rates of energy and matter fluxes (see Chapter 4).

Changes in the relative abundance or biomass of functional groups can signal changes in the rate and direction of ecological processes. For example, changes in the relative proportions of filter-feeder vs. shredder functional groups in aquatic ecosystems affect the ways in which detrital resources are processed within the stream community and their contribution to downstream communities. Similarly, changes in the relative proportions of folivores vs. sap-suckers affect the flux of nutrients as solid materials vs. liquid (e.g., honeydew) and their effect on the detrital community (e.g., Schowalter and Lowman 1999, Stadler and Müller 1996, Stadler et al. 1998).

The functional group concept permits a convenient compromise in dealing with diversity, i.e., sufficient grouping to simplify taxonomic diversity while retaining an ecologically relevant level of functional diversity. Therefore, the functional group approach has become widely used in ecosystem ecology.

## II. PATTERNS OF COMMUNITY STRUCTURE

A central theme of community ecology has been the identification of patterns in community structure across environmental gradients in space and time (see also [Chapter 10](#)). The diversity of community types at landscape and regional scales has been a largely neglected aspect of biodiversity, but is important to the maintenance of regional species pools and metapopulation dynamics for many species. In addition, the mosaic of community types on a landscape may confer conditional stability to the broader ecosystem, in terms of relatively consistent proportions of community types over time (see [Chapters 10 and 15](#)).

Identification of patterns in community organization has become increasingly important to population and ecosystem management goals. Introduction of exotic insects to combat noxious pests (weeds or other insects) requires that attention be paid to the ability of the biocontrol agent to establish itself within the community and to its potential effects on non-target components of that community. Efforts to conserve or restore threatened species require consideration and maintenance of the underlying community organization.

Depending on the descriptive approach taken (see above), patterns have been sought in terms of species diversity, food web structure, or guild or functional group composition. Unfortunately, comparison of data among communities has been hampered by the different approaches used to describe them, compounded by the variety of sampling techniques, with their distinct biases, that have been used to collect community data. For example, sweep netting, light trapping, interception trapping, pitfall trapping, soil coring, canopy fumigation and branch bagging are among the techniques commonly used to sample terrestrial arthropods (Leather 2005). These techniques differ in their representation of nocturnal vs. diurnal flying insects, arboreal vs. soil/litter species, and sessile vs. mobile species, etc. (e.g., Blanton 1990, Leather 2005, Majer and Recher 1988, Southwood 1978). Variation in the mesh size of sampling nets affects the representation of aquatic species (Storey and Pinder 1985). Relatively few studies have used the same or similar techniques, to provide comparative data among community types or locations. Some proposed patterns have been challenged as subsequent studies provided more directly comparable data or increased the resolution of arthropod taxonomy (e.g., C. Hawkins and MacMahon 1989, Polis 1991b, Reagan et al. 1996). Disturbance history, or stage of post-disturbance recovery, also affects community structure (e.g., Harding et al. 1998, Schowalter et al. 2003, E. Wilson 1969, see [Chapter 10](#)). However, the history of disturbance at sampled sites often is unknown, potentially confounding any interpretation of differences in community structure. Nevertheless, apparent patterns that have been identified at a variety of spatial scales may serve as useful hypotheses to guide future studies.

### A. Global Patterns

Communities can be distinguished on a taxonomic basis at a global scale because of the distinct faunas among biogeographic realms (A. Wallace 1876). However, similar community types on different continents often are dominated by unrelated species with similar

attributes, termed **ecological equivalence**. For example, grassland communities on every continent should show similar food web structure and functional group organization, reflecting similar environmental conditions, regardless of taxonomic representation. A number of studies have indicated global patterns in community structure that are related to latitudinal gradients in temperature and moisture, and to the ecological history of adaptive radiation of particular taxa.

Latitudinal gradients in temperature and precipitation establish a global template of habitat suitability, as discussed in Chapters 2 and 7. Equatorial areas, characterized by high sun angle and generally high precipitation, provide favorable conditions of light, temperature and moisture, although seasonal patterns of precipitation in some tropical areas create periods of adverse conditions for many organisms. The strongly seasonal climate of the temperate zones requires specific adaptations for survival during unfavorable cold periods, thereby limiting species diversity. The harsh conditions of temperate deserts and high latitude zones generally restrict the number of species that can be supported or that can adapt to these conditions.

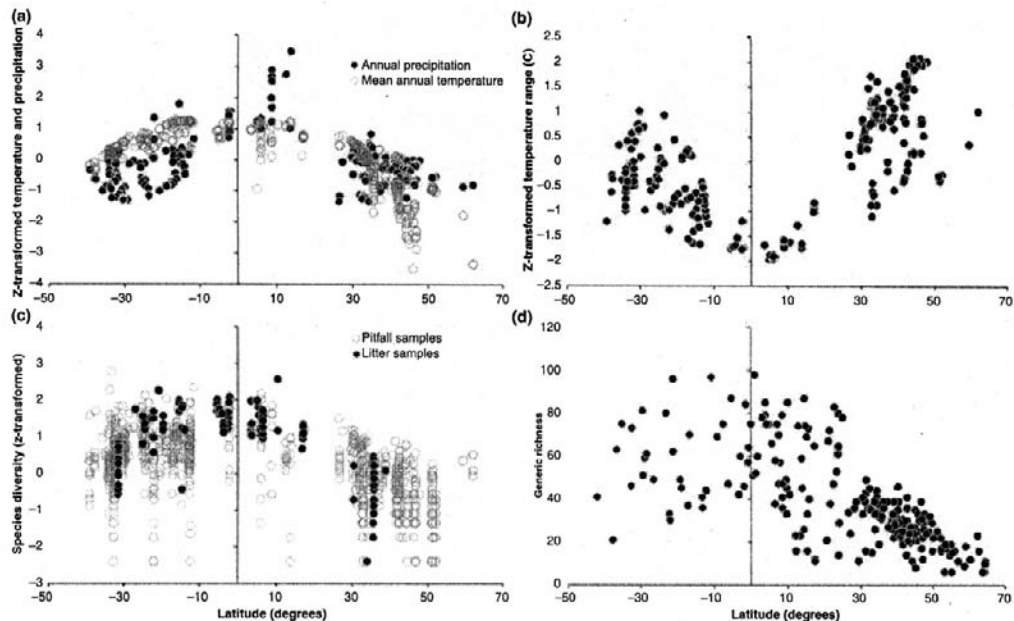
Species richness generally decreases with latitude for a wide variety of taxa (R. Dunn et al. 2009, Gaston 2000, Price 1997, J. Stout and Vandermeer 1975, Wiens et al. 2006, Willig and Lyons 1998). Latitudinal gradients are especially pronounced for insects, with some studies suggesting that the tropics support several million undescribed arthropod species (Erwin 1995, May 1988, E. Wilson 1992), depending on scale-dependent estimates of specialization of herbivorous groups among plant species (Gering et al. 2007). Latitudinal trends may not be reflected by all taxa (e.g., aphids, Dixon 1985) or component communities (Vinson and Hawkins 1998). Although L. Dyer et al. (2007) reported that the larval diets of tropical Lepidoptera were more specialized than those of temperate forest caterpillars, contributing to higher diversity of this group in tropical forests, Novotný et al. (2006) found similar levels of specialization between tropical and temperate Lepidoptera and concluded that the greater diversity of this group in the tropics reflected the greater diversity of plants. Lewsinsohn and Roslin (2008) conducted a meta-analysis of studies that compared temperate and tropical herbivore diversity and found that correlation between plant and herbivore diversity explained 60% of the variation in insect species richness. They concluded that higher insect diversity in the tropics reflects the greater diversity of host plants. Vinson and Hawkins (1998) reviewed the literature for stream communities and concluded that species richness is highly variable, and no strong latitudinal trends are apparent. Furthermore, Willig and Lyons (1998) showed that latitudinal gradients can result from chance. Nevertheless, a number of hypotheses have been proposed to explain latitudinal gradients in species richness.

Terborgh (1973) showed that the apparent trend in species richness with latitude can reflect increasing land area toward the equator. He noted that climate is relatively constant across a wide belt between latitudes 20° N and S but shows a distinct gradient above those latitudes. Combining climate and surface area gradients yielded a latitudinal gradient in habitat area available within each climate class, with a preponderance of global surface area in tropical habitats. These data suggest that the gradients in species richness reflect the habitat area that is available for within-habitat speciation (see discussion below).

Latitudinal gradients in species richness also may reflect greater primary productivity in the tropics (Rosenzweig and Abramsky 1993, Tilman and Pacala 1993, Waide et al. 1999; see below). Hutchinson (1959) proposed that animal diversity is related to the energy available in ecosystem primary production. D. Currie (1991) subsequently

demonstrated that North American patterns of plant and vertebrate diversity were related to environmentally-available energy. More recently, A. Allen et al. (2002) and J. Brown et al. (2004) proposed a **metabolic theory of ecology** that explained latitudinal gradients in diversity as a result of relationships between temperature, body size and metabolic rate that determine the maximum population sizes attainable, given the energy and nutrients available in the ecosystem. All other factors being equal, available energy will support more small organisms than larger ones, and warm environments will support more organisms than cold environments. Algar et al. (2007) and B. Hawkins et al. (2007) tested the prediction of metabolic theory that the natural logarithm of species richness (of a variety of data sets for trees, blister beetles, tiger beetles, butterflies, amphibians and reptiles) is a linear function of temperature. All taxa tested showed a curvilinear relationship to temperature, rather than the predicted linear relationship, indicating that energy availability alone is not a sufficient explanation for latitudinal gradients in species richness.

Finally, evolutionary time may explain latitudinal gradients for some taxa. Wiens et al. (2006) found that tree frog diversity was strongly correlated with time since colonization of a region, but not with latitude per se. However, since these frogs originated in tropical South America and spread to temperate regions relatively recently, there has been more time for speciation in the tropics than in temperate regions. R. Dunn et al. (2009) evaluated the asymmetry in ant species richness between northern and southern hemispheres (Fig. 9.8) and concluded that the greater climate change since the Eocene in the northern hemisphere had resulted in more extinctions and reduced species richness relative to the southern hemisphere.



**FIG. 9.8** Latitudinal trends in a) mean annual precipitation and temperature, b) temperature range, c) local species richness of ants, and d) regional richness of ant genera. Negative latitudes are for the southern hemisphere. Generic richness is derived from lists of species and genera from countries and smaller political regions and presented for comparison. From R. Dunn et al. (2009) with permission from John Wiley & Sons.

Superimposed on the latitudinal gradients are the relatively distinct biogeographic realms identified by Wallace (1876). These realms reflect the history of continental break-up, with southern floras and faunas being largely distinct from northern floras and faunas (see Chapter 7). However, the southern continents show a varied history of reconnection with the northern continents that has resulted in invasion, primarily by northern species. The proximity of North America and Eurasia has facilitated movement of species between these land masses, leading to development of a Holarctic species component, especially within the arctic and boreal biomes. Whereas many genera, and even some species, occur throughout the Holarctic realm, the flora and fauna of Australia have remained relatively distinct as a result of continued isolation.

Species richness also may be related to geological time. E. Wilson (1969) suggested that coevolution should improve the efficiency of total resource exploitation and lead to further increase in coexisting species over time. In other words, a habitat or resource that has persisted for a longer period of time would acquire more species than a more recently derived habitat or resource. Birks (1980) found that the residence time of tree species in Britain was strongly correlated with the diversity of associated insect species. Tree species that had a longer history of occurrence in Britain hosted a larger number of species than did tree species with shorter residence times. Again, because residence time is correlated with area of occurrence (habitat area), the effects of these two factors cannot be distinguished easily (Price 1997, see below).

## B. Biome and Landscape Patterns

Patterns in species richness, food web structure and functional organization have been observed among biomes and across landscapes. To some extent, patterns may reflect variation in occurrence or dominance of certain taxa in different biomes. Regional species pools may obscure effects of local habitat conditions on species richness (Kozár 1992a), especially in temperate ecosystems (Basset 1996), but few ecologists have addressed the extent to which the regional species pool may influence local species richness. Gering et al. (2003), Kitching et al. (1993) and Progar and Schowalter (2002) distinguished arthropod assemblages among sites within biomes that reflected regional gradients in environmental conditions. Various hypotheses have been proposed to account for apparent meta-community patterns at the biome and landscape level (e.g., Leibold and Mikkelsen 2002, Price 1997, Tilman and Pacala 1993). Patterns include nested subsets (Summerville et al. 2002), checkerboards and various types of gradients (Leibold and Mikkelsen 2002). Leibold and Mikkelsen (2002) proposed a set of criteria to distinguish which pattern characterizes a given landscape. **Coherence** is the degree to which a pattern can be represented by a single dimension, **species turnover** is the number of species replacements along this dimension, and **boundary clumping** describes how the edges of species ranges are distributed along this dimension. Presley et al. (2010) described additional patterns and demonstrated that combinations of patterns at fine spatial scales can aggregate to form different patterns at larger scales.

General functional groups are common to all terrestrial and aquatic biomes, e.g., grazing herbivores (depending on degree of autochthonous primary production in streams), predators, parasites, and detritivores, whereas other functional groups depend on particular resources being present, e.g., sap-suckers require vascular plants, and wood borers require wood resources. The proportions of the fauna that represent the different functional groups vary among biomes. Low order streams have primarily detrital-based

resources, and their communities are dominated by detritivores and associated predators and parasites. Other communities represent various proportions of autotroph functional groups (e.g., chemoautotrophs, ruderal, competitive, and stress-tolerant vascular vs. non-vascular plants) and heterotroph functional groups (herbivores, predators, detritivores) (see Chapter 11).

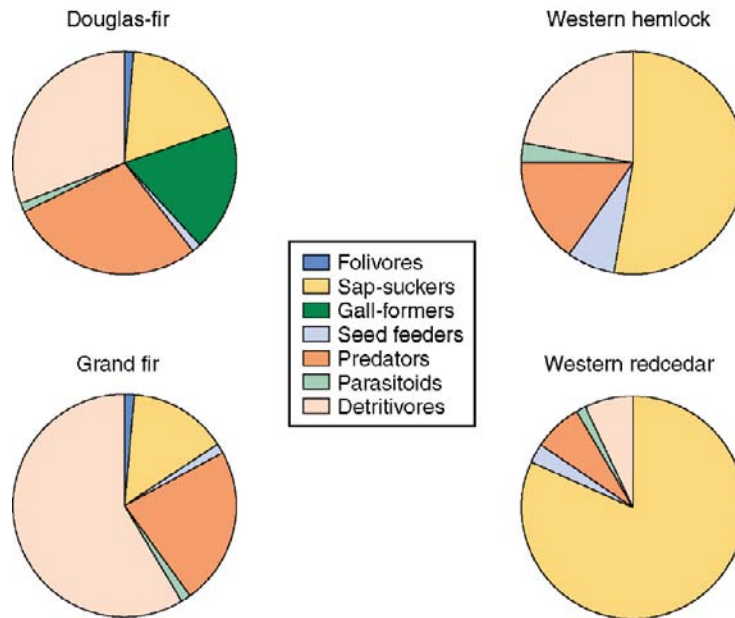
Different species compose these functional groups in different biomes. For example, the insect grazer functional group is composed primarily of moths, beetles, and tree crickets in broadleaved forests, moths and sawflies in coniferous forests (Schowalter 1995, Schowalter and Ganio 1999, Schowalter et al. 1981c), grasshoppers in grasslands and shrublands (Curry 1994), and caddisflies and flies in aquatic communities (e.g., Hart 1992). The predator functional group in terrestrial arthropod communities is dominated by a variety of arachnids, beetles, flies and wasps, whereas in aquatic arthropod communities this functional group is dominated by dragonflies, true bugs and beetles.

Among terrestrial biomes, species richness generally is assumed to increase from harsh biomes (e.g., tundra and desert) to grassland to forest, again reflecting differences in physical complexity, suitability and stability of the habitat (Bazzaz 1975, Tilman and Pacala 1993). However, this trend is not apparent for arthropods among communities where extensive species inventories are available (e.g., Table 9.1). Species richness is not always linearly related to primary productivity, and patterns likely depend on scale (Rosenzweig and Abramsky 1993, Tilman and Pacala 1993, Waide et al. 1999). Species richness often declines above intermediate levels of productivity, perhaps because more productive communities are dominated by larger individuals that reduce habitat heterogeneity, or because more productive and stable communities favor competitive exclusion of some species by the best adapted species (Tilman and Pacala 1993). For example, continuous fertilization of permanent pasture at Rothamsted, U.K. since 1856 has resulted in changes in the species rank-abundance pattern from a log normal curve in 1856 to progressively more geometric curves by 1949 (Fig. 9.3) (Kempton 1979).

Functional group composition has not shown consistent differences among biomes (C. Hawkins and MacMahon 1989, Stork 1987). Detritivores generally represent a greater proportion of the community in boreal forests, headwater streams, and other biomes characterized by accumulated organic material and a lower proportion in tropical forests, deserts and other biomes with little organic matter accumulation (Haggerty et al. 2002, Seastedt 1984). Wood borers occur only in forest or shrub ecosystems with abundant wood resources. Pollinators are more diverse in tropical forests and deserts, where plant diversity and isolation have led to greater reliance on insect and vertebrate pollinators, compared to temperate grassland and forest, and arctic biomes. Proportional representation of species and individuals among functional groups varies widely among canopy arthropod communities in temperate and tropical forests, depending on tree species composition (Fig. 9.9) (V. Moran and Southwood 1982, Schowalter and Ganio 1998, 1999, Stork 1987).

At the landscape or drainage basin scale, patterns in species richness and functional group organization can be related to local variations in physical conditions. The history and geographic pattern of disturbance may be particularly important factors for determining the variation in community structure. Polis et al. (1997a) concluded that the movement of organisms and resources among the interconnected community types comprising a landscape can contribute to the organization of the broader landscape community by subsidizing more resource-limited local communities. However, Basset (1996) found that the diversity in the trees of the tropical rain forest was related to five factors: numbers of young leaves available throughout the year, ant abundance, leaf palatability, leaf water





**FIG. 9.9** Functional group organization of arthropod communities in canopies of four old-growth conifer species at the Wind River Canopy Crane Research Facility in southwestern Washington. Data from Schowalter and Ganio (1998).

content, and altitudinal range. These data suggest that local factors may be more important determinants of local species diversity and community structure in complex ecosystems, such as tropical forests, than in less complex ecosystems, such as temperate forests.

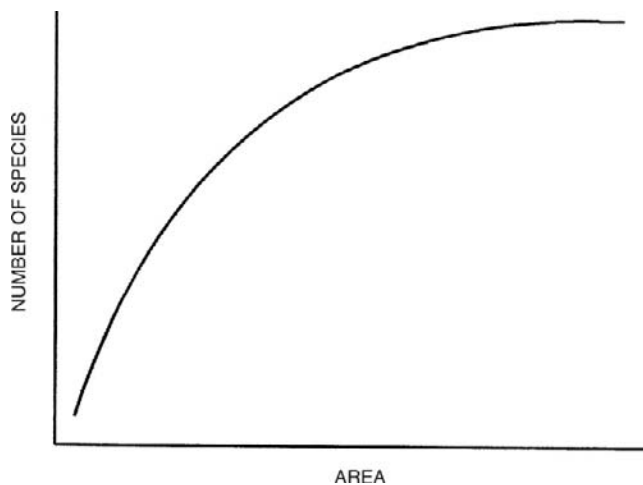
Diversity of stream insects varies among riffle and pool habitats and substrate conditions (Ward 1992). Diversity generally is higher in running water with cobble substrates, with high oxygen supply and heterogeneous structure, than in standing water with mud, sand or gravel substrates. Vinson and Hawkins (1998) reviewed six studies that compared species richness of stream insects over drainage basins. Species diversity varied with elevation, which co-varied with a number of important factors, such as stream morphology, flow rate and volume, riparian cover, and agricultural or urban land use. In one study J. Carter et al. (1996) used multivariate analysis (TWINSpan) to compare species composition among 60 sites representing first-order (characterized by narrow V-shaped channel, steep gradient, nearly complete canopy cover) to sixth-order (characterized by wide channel, low gradient, little canopy cover) streams over a 15,540 km<sup>2</sup> drainage basin. They identified five communities that were distinguished largely by elevation. The highest species richness occurred in mid-order, mid-elevation streams that included species groups characterizing both higher- and lower-order streams.

Transition zones (ecotones) between community types typically have higher species richness, because they represent habitat variables and include species from each of the neighboring communities (e.g., Muff et al. 2009). Zhong et al. (2003) reported that the diversity of adult mosquito species was higher at sites that were surrounded by freshwater and salt-marsh than at those surrounded by either freshwater or salt-marsh alone. However, Sabo et al. (2005) reported that riparian zones represent unique habitats that support species not represented in the neighboring communities. Ecotones can move across the landscape as environmental conditions change. For example, the northern edge of

Scots pine, *Pinus sylvestris*, forest in Scotland moved rapidly 70–80 km northward about 4000 yrs ago then retreated southward again about 400 yrs later (Gear and Huntley 1991). Sharp edges between community types, such as those that result from land use practices, reduce the value of this ecotone as a transition zone.

Patches at different stages of post-disturbance recovery show distinct patterns of species richness, food web structure, and functional group organization (see Chapter 10). Species richness typically increases during community development up to an equilibrium, perhaps declining somewhat prior to reaching equilibrium (e.g., MacArthur and Wilson 1967, E. Wilson 1969). As the number of species increases, the number of species interactions increases. Food chains that characterize simpler communities develop into more complex food webs (E. Wilson 1969). Schowalter (1995), Schowalter and Ganio (1999) and Schowalter et al. (1981c) found that patches of recently disturbed temperate and tropical forests were characterized by higher sap-sucker/folivore ratios than were patches of undisturbed forests, even when the data were reported as biomass.

Shure and Phillips (1991) found that species richness and functional group composition were modified by manipulated patch size (Fig. 6.6). Species richness was lowest in mid-sized canopy openings (0.08–0.4 ha). Herbivore guilds generally had the lowest biomass in mid-sized canopy openings; omnivore biomass peaked in the smallest openings (0.016 ha) and then declined as opening size increased; predator biomass was highest in the control forest and smallest openings, and lowest in the mid-sized openings; and detritivore biomass was similar among most openings, but much lower in the largest openings (10 ha). This pattern may indicate the scale that distinguishes communities characterizing closed-canopy and open-canopy forest. Smaller openings were influenced by surrounding forest, whereas larger openings favored species that were tolerant of solar exposure and altered plant conditions, e.g., early successional species and higher phenolic concentrations (Dudt and Shure 1994, Shure and Wilson 1993). Openings of intermediate size may be too exposed for forest species, but insufficiently exposed for earlier successional species. However, species richness generally increases with habitat area (Fig. 9.10) (M.P. Johnson and Simberloff 1974, MacArthur and Wilson 1967), for reasons discussed below.



**FIG. 9.10** Relationship between species richness and geographic area.

### III. DETERMINANTS OF COMMUNITY STRUCTURE

A number of factors affect community structure (e.g. Price 1997). Factors associated with habitat area, stability, habitat or resource conditions, and species interactions appear to have the greatest influence.

#### A. Habitat Area and Complexity

The relationship between number of species and sampling effort, in time or space, has been widely recognized and supported (He and Legendre 2002). The increase in number of species with increasing number of samples reflects the greater representation of the community. Similarly, a larger habitat area will “sample” a larger proportion of a regional species pool (Summerville and Crist 2004). Summerville et al. (2002) found that larger patches hosted more butterfly species because habitat generalists tended to colonize all patch sizes, whereas habitat specialists avoided the smallest patches in favor of larger patches. Increasing habitat area also tends to represent increasing heterogeneity of habitat conditions (e.g., M. Johnson and Simberloff 1974, D. Strong et al. 1984), providing an increasing number of niches. Larger water bodies have higher diversities of aquatic insects (Paradise 2004).

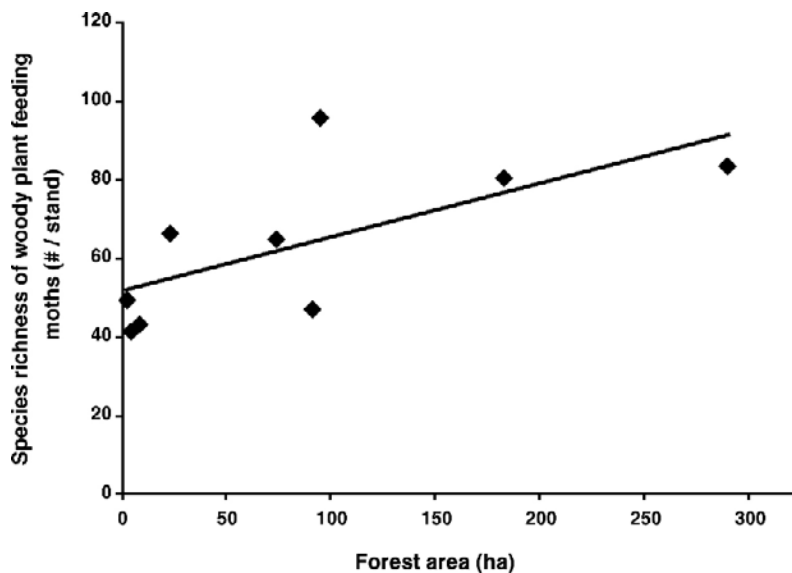
In developing the **Theory of Island Biogeography**, MacArthur and Wilson (1967) emphasized the relationship between species richness (S) and island area (a), expressed as:

$$S = Ca^z \quad (9.10)$$

where C depends on the taxon and biogeographic region, and z is a parameter that varies little among taxa or biogeographic regions, generally falling in the range 0.20–0.35 (Fig. 9.10). The value of z increases with habitat heterogeneity and proximity to the mainland. For non-isolated sample areas within islands or within continental areas, the relationship between species number and sample area is similar, but z is smaller, generally 0.12–0.17 (MacArthur and Wilson 1967).

Habitat area has continued to be viewed as a primary factor that affects species richness, likely influencing apparent gradients in species richness with latitude and host residence time (e.g., Birks 1980, Price 1997, Terborgh 1973), as discussed above. However, habitat area is also a surrogate for habitat heterogeneity. Larger islands are more likely to represent a wider range in elevation, soil types, aspects, etc. than are smaller islands. Similarly, larger continental areas are more likely than smaller areas to represent a range of habitat conditions. Because relatively distinct component communities develop on particular resources, such as plant or microbial species (e.g., J. Moore and Hunt 1988), species richness increases exponentially as representation of resource diversity increases. Furthermore, habitat heterogeneity provides refuges from competition and/or predation, i.e., local patches of competition- or predator-free space (Covich et al. 2009, Finke and Denno 2006). The architectural complexity of individual plants also can affect the diversity of associated fauna (Lawton 1983).

Fragmentation of habitat types often alters species richness and other measures of diversity. Larger fragments retain a greater proportion of species richness than do smaller fragments (Fig. 9.11) (Collinge 2000, Kruess and Tschardtke 2000, Summerville and Crist 2004, Summerville et al. 2002). Species that are characteristic of the fragmented habitat often are replaced by species characterizing the surrounding matrix (e.g., Summerville

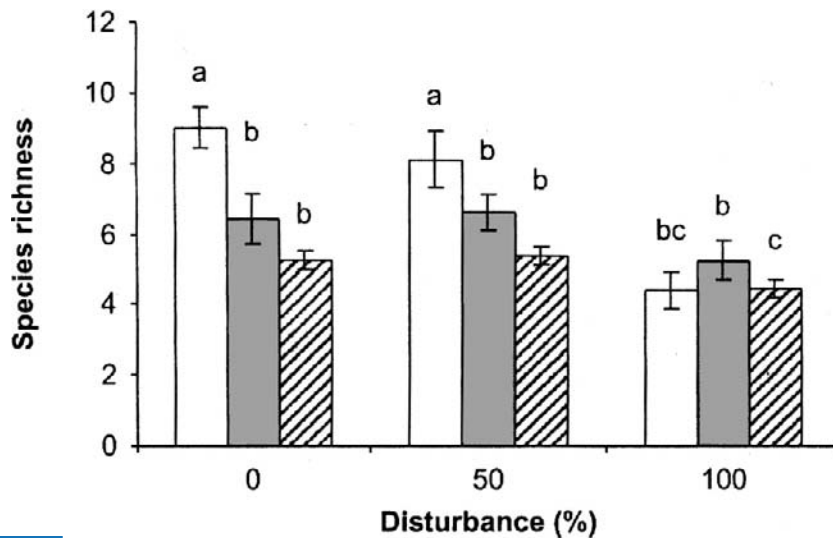


**FIG. 9.11** Significant ( $P < 0.05$ ,  $R^2 = 0.61$ ) relationship between the size of forest fragments and number of woody-plant-feeding moth species in the western Allegheny Plateau of eastern North America. From Summerville and Crist (2004) with permission from John Wiley & Sons.

and Crist 2004). Some guilds may be more sensitive to fragmentation than are others. Golden and Crist (1999) reported that sap-sucking herbivores and parasitoids were significantly reduced by fragmentation of a goldenrod community, but chewing herbivores and predators were largely unaffected. Overall insect species richness was reduced by fragmentation, primarily through loss of the rare species.

## B. Habitat Stability

Habitat stability determines the length of time available for community development (see Chapter 10). E. Wilson (1969) proposed four stages in community development. The **non-interactive stage** occurs on newly available habitat or immediately following a disturbance, when numbers of species and population sizes are small. As species number rises during **the interactive stage**, competition and predation influence community structure, with some species disappearing and new species arriving. The **assortative stage** is characterized by persistence of species that can co-exist and utilize resources most efficiently, facilitating species packing. Finally, the **evolutionary stage** is characterized by co-evolution that increases the efficiency of overall utilization and species packing. Disturbances restrict diversity to species that are tolerant of altered conditions (Cole et al. 2008, Fig. 9.12, see also Chapter 2). Community development in frequently disturbed habitats cannot progress beyond earlier stages, whereas more stable habitats permit advanced community development and increased species richness. However, the most stable habitats also allow the most adapted species to pre-empt resources from other species, leading to a decline in species richness (see below). This trend has led to the development of the **Intermediate Disturbance Hypothesis**, which predicts that species richness peaks at intermediate levels of disturbance (e.g., Connell 1978, Sousa 1985, but see Reice 1985). Community recovery from disturbance is described more fully in Chapter 10.



**FIG. 9.12** Response of oribatid (open bars) and mesostigmatid (shaded bars) mites and Collembola (hatched bars) to soil disturbance treatment (proportion of plot with soil disrupted to simulate livestock trampling) in 2001. Vertical lines represent standard errors, and bars with the same letter do not differ at  $P < 0.05$ . Reprinted from Cole et al. (2008) with permission from Elsevier.

### C. Habitat or Resource Conditions

Habitat conditions establish the template that determines the ability of particular species to survive and persist. Physical conditions include temperature, water availability, chemistry, etc. (see Chapter 2). S. Miller et al. (2007) reported that the withdrawal of water from streams for irrigation purposes altered habitat conditions for aquatic invertebrate communities. Changes in water depth, flow rate and wetted habitat were proportional to the amount of water removed, whereas changes in conductivity and temperature were observed only when water removal exceeded 85% of ambient levels. Removal of more than 90% of the water and temperatures above 30°C resulted in a shift in community structure from dominance by collector-gatherer and filterer Ephemeroptera, Plecoptera and Trichoptera to dominance by scraper elmids, beetles, predators and non-insect taxa.

As discussed above, the availability of particular resources determines presence of associated species. If a limiting resource (host) becomes more abundant, then associated species also become more abundant, until some other factor(s) become limiting. For example, Siemann (1998) and Cole et al. (2008) reported that experimental fertilization of grassland plots increased arthropod species richness and abundance. Doi (2009) reviewed studies of spatial patterns in allochthonous and autochthonous aquatic resources and concluded that connectivity of food webs based on these different resources along the stream continuum is critical to the sustainability of top predators that require a diversity of prey.

Limiting resources may preclude any single adaptive strategy from becoming dominant, and thereby maintain high species richness. Rosenzweig and Abramsky (1993), Tilman and Pacala (1993) and Waide et al. (1999) concluded that species richness is not always linearly related to productivity. Intermediate levels of productivity often support the highest diversity, because higher productivity favors dominance by the most competitive species.

Mittelbach et al. (2001) compiled 171 published studies that related species richness to productivity for aquatic and terrestrial plants and animals. Hump-shaped relationships were the most common, indicating that productivity generally was highest at intermediate levels of species richness.

Diversity at each trophic level is affected by the diversity of resources available (M.T. Johnson and Agrawal 2005, M.T. Johnson et al. 2006). As described above (e.g., Fig. 9.9), each plant species hosts a relatively unique assemblage of associated herbivores, each of which in turn hosts a relatively unique assemblage of parasites and, to a lesser extent, predators. Therefore, the diversity of arthropod assemblages is a function of the diversity of plant assemblages (Curry 1994, Lewinsohn and Roslin 2008, Magurran 2004, Novotný et al. 2006, Stiling 1996). Even within a given plant species, the genetic diversity of the plant population influences the diversity of the associated arthropods (Bangert et al. 2006, Crutsinger et al. 2006, M.T. Johnson and Agrawal 2005, Wimp et al. 2007). Genetically diverse plant populations represent a more complex habitat than do genetically similar populations. Complexity of plant architecture also influences the diversity of associated arthropods (Jeffries et al. 2006).

Unique communities develop on particular substrates that are embedded within the background matrix. For example, specialized species assemblages characterize serpentine soils and wetlands. Sabo et al. (2005) reported that riparian zones support species that do not occur in surrounding habitats, thereby enriching regional species diversity.

A number of studies have compared species richness between relatively homogeneous and heterogeneous environments (e.g., Cromartie 1975, S. Risch 1980, 1981, Root 1973, D. Strong et al. 1984, Tahvanainen and Root 1972). Because organisms have greater difficulty maintaining energy and nutrient balance when resources are scattered (see Chapter 4), the abundance of individual species generally decreases with increasing resource heterogeneity, precluding exclusive use of the niche and permitting species richness to increase. By contrast, homogeneous resources facilitate the rise to competitive dominance by the best-adapted species, leading to reduced species richness. Extensive planting of agricultural or silvicultural monocultures establishes the conditions necessary for some species to reach epidemic population levels across landscapes (see Chapter 7), reducing availability of resources shared with other species but providing prey resources for predators (Polis et al. 1997a, see also Chapter 8).

#### D. Species Interactions

Species interactions can enhance or preclude persistence of some species, as discussed in Chapter 8. As noted above, species populations cannot persist where their resources are absent. However, the presence of competitors, predators and mutualists also affects the persistence of associated species, both directly and indirectly. In the past, species interactions often were viewed as evidence of co-evolution. However, species that colonize new areas can occupy vacant niches through pre-adaptation, i.e., similarity between their native and new habitat (Diamond 1990, Janzen 1985, Janzen and Martin 1982). S. Gould and Vrba (1982) proposed the term “exaptation” to describe characteristics that were evolved for other purposes but that “preadapt” an organism to current conditions.

Some species can have particularly profound effects on community structure. Their presence leads to a different community structure than would occur in their absence. A top predator that preys preferentially on the most abundant of several competing prey species can prevent the best adapted species from competitively suppressing others, thereby maintaining higher diversity than would occur in the absence of that predator. R. Paine

(1966, 1969a, b) considered such species to be **keystone species**. Bond (1993) and Power et al. (1996) applied this term to any species that have effects on ecosystem structure or function that are disproportionate to their abundance or biomass.

Some insect species could be considered to be keystone species, to the extent that their abundance greatly alters diversity, productivity, rates of energy, or nutrient flux, etc. Many herbivorous insects increase the diversity of plant species by selectively reducing the density of abundant host species and providing space and resources for non-host plants (Lawton and Brown 1993, Schowalter and Lowman 1999). The southern pine beetle, *Dendroctonus frontalis*, is capable, at high population densities, of killing pine trees and increasing the availability of woody resources that maintain populations of other xylophagous species (Flamm et al. 1993). Naiads of the large dragonfly, *Tramea lacerata*, prey on other dragonflies as well as on various other taxa that also are prey of other dragonfly and damselfly naiads. Wissinger and McGrady (1993) found that addition of *T. lacerata* to wetland communities had a direct negative effect on damselfly prey, but also had an indirect positive effect through the reduced numbers of other predaceous dragonflies. Termites and ants affect soil structure and fertility in ways that determine vegetation development (Brody et al. 2010, Fox-Dobbs et al. 2010, see Chapters 13 and 14).

Céréghino et al. (2010) described the influence of two ant species, *Pachycondyla goeldii* and *Camponotus femoratus*, on the diversity of invertebrates associated with a bromeliad, *Aechmea mertensii*, an ant-garden mutualistic epiphyte. These ants incorporate the fruits and seeds of the bromeliad into their arboreal carton nests, providing for dispersal and protection from herbivores, and the bromeliad subsequently covers the nest, anchoring and stabilizing the nest and providing food rewards to the ants. The ants control the size and shape of bromeliads by determining their location, from exposed to partially shaded habitats, and thereby create a gradient of aquatic habitat sizes and resources that increases the diversity of associated aquatic invertebrates.

As discussed in Chapter 6, the combination of bottom-up (resource supply) and top-down (trophic cascades) factors tends to stabilize population levels. Changes in the abundance of any trophic level, however, affect abundances at other trophic levels. Generally, an increase in abundance at one trophic level will increase the resources that are available to the next trophic level up, hence increasing abundance at that level, but reducing abundance at the next lower level. Reduced abundance at the lower trophic level reduces its control over the second lower trophic level, which increases in abundance and reduces abundance at the third lower trophic level.

Trophic cascades appear to be more common and pronounced in aquatic ecosystems (Batzer et al. 2000b, Carpenter and Kitchell 1984, 1987, 1988, Vanni and Layne 1997) than in terrestrial ecosystems (Shurin et al. 2002), but this may be related to the productivity of the system. J. Chase et al. (2000) used large herbivore exclosures to demonstrate that consumer effects were more pronounced at lower primary productivity, and herbivore effects were weaker at higher productivity, reflecting a dampening of overall herbivore effects by greater plant species turnover at higher productivity.

M.D. Hunter et al. (2003) reported that the exclusion of litter predators in litterbags increased Collembola abundances and litter decomposition rate. Beard et al. (2003) excluded frogs, *Eleutherodactylus coqui*, in tropical rainforest plots, and observed that frogs reduced invertebrate abundance and herbivory and increased foliage production. Stiling and Moon (2005) reported that parasitoid exclusion increased herbivore abundance and reduced plant growth.

L. Dyer and Letourneau (1999a, b) and Letourneau and Dyer (1998) described a trophic cascade in a neotropical rain forest community. Clerid beetle, *Tarsobaenus letourneauae*, predation on ants, especially *Pheidole bicornis*, reduced ant abundance and increased herbivore abundance and herbivory on *Piper cenocladum* ant-plants. Where this beetle was absent, and spiders were a less effective top predator, ant abundance was higher, and herbivore abundance was lower (Fig. 9.13). Manipulation of top-down and bottom-up effects indicated that increased resources (light and nutrients) directly increased plant biomass but had no indirect effect on intermediate or top predators, but ant exclusion indirectly affected plant biomass by increasing herbivory (L. Dyer and Letourneau 1999a).

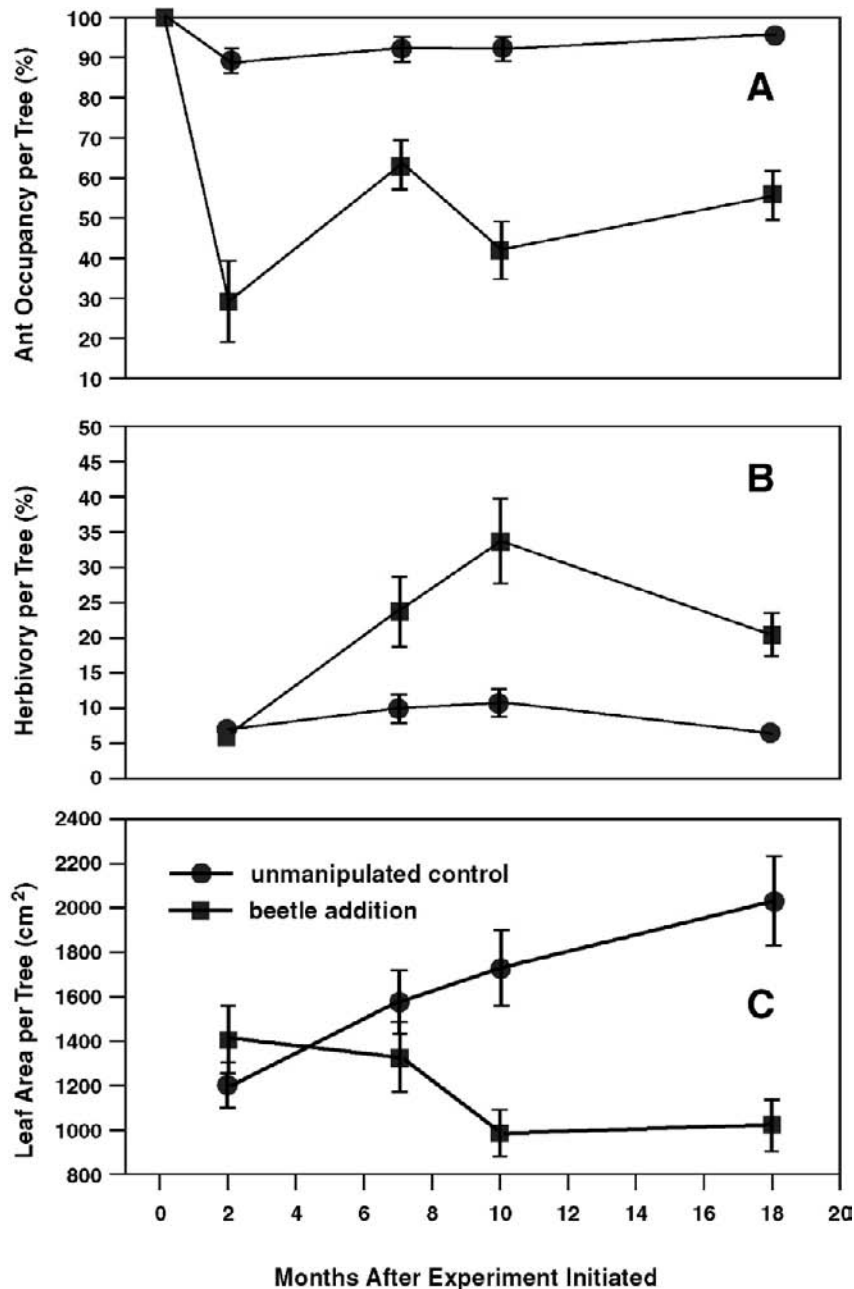
The ability to induce trophic cascades apparently differs among community types and predator species (e.g., C. Huang et al. 2007, Leroux and Loreau 2008). Several factors appear to determine cascade strength. Ecosystems that have high productivity or receive large amounts of allochthonous subsidies (e.g., aquatic ecosystems) should have the strongest trophic cascades, especially if the subsidies are disproportionately available to plants and predators (Leroux and Loreau 2008). Predator diversity and habitat complexity determine predator foraging efficiency and degree of intraguild predation (Finke and Denno 2006, Letourneau et al. 2009, Straub and Snyder 2008). Finally, variation in herbivore-plant interaction, e.g., plant defenses and compensatory growth ability (Shurin et al. 2002), or other species interactions (Mooney 2006) may buffer trophic levels from cascading effects. Mooney (2007) excluded birds and/or ants, primarily *Formica podzolica*, from experimental mature ponderosa pine, *Pinus ponderosa*, trees in Colorado, U.S. (Fig. 9.14). She found that birds and ants reduced the abundances of folivorous and predaceous arthropods in an additive manner, with the effect of ants being stronger than that of birds. The abundance of ants doubled, and that of tended aphids, *Cinara* spp, tripled, when birds were excluded. However, the ants only increased the abundance of tended aphids in the absence of birds, whereas birds only reduced their abundance in the presence of ants, apparently because of bird disruption of the aphid-ant interaction. Predation by birds, but not ants, resulted in increased wood and foliage growth.

Linkages between communities can affect trophic cascades. Terrestrial arthropod inputs to aquatic systems can represent up to half of the annual diet of many fish (J. Allan et al. 2003, Baxter et al. 2005, Kawaguchi and Nakano 2001, Nakano and Murakami 2001, Pray et al. 2009) and can influence predator-prey interactions. Nakano et al. (1999) experimentally manipulated terrestrial arthropod inputs and predatory fish presence in forest headwater streams in northern Japan. When terrestrial arthropod inputs were reduced, predatory fish switched from terrestrial to aquatic arthropod prey, reducing aquatic arthropod abundance and increasing periphyton biomass. By contrast, removal of predatory fish did not significantly alter the food web, indicating that the trophic cascade was controlled by terrestrial arthropod inputs. On the other hand, Knight et al. (2005a) found that terrestrial-aquatic cascades worked in the opposite direction, as well. Fish reduced dragonfly larvae in ponds, leading to fewer dragonfly adults and reduced predation on pollinators in adjacent terrestrial habitats. As a result, plants near ponds with fish had more pollinator visits and were less pollen limited than were plants near ponds without fish (Fig. 9.15) Such linkages control fluxes of energy and nutrients between ecosystems.

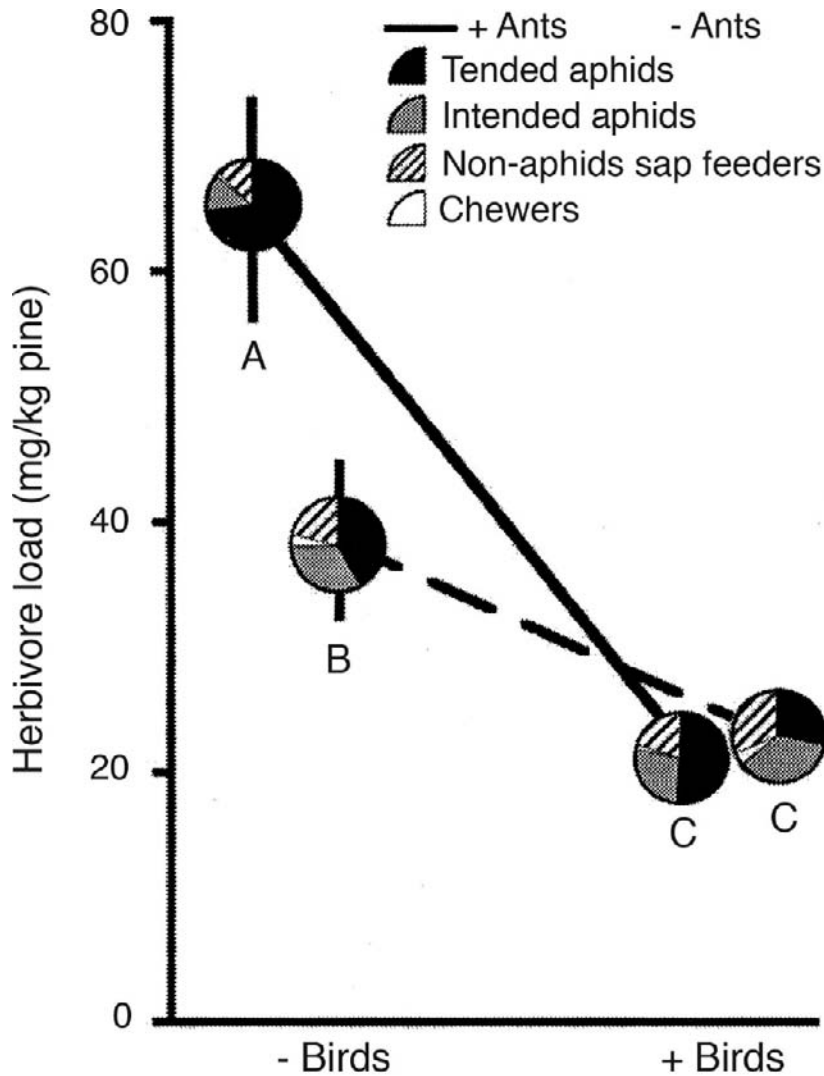
#### IV. SUMMARY

Communities are composed of the species that occupy a site. Identification of patterns in community structure has been a major goal of ecological research. However,





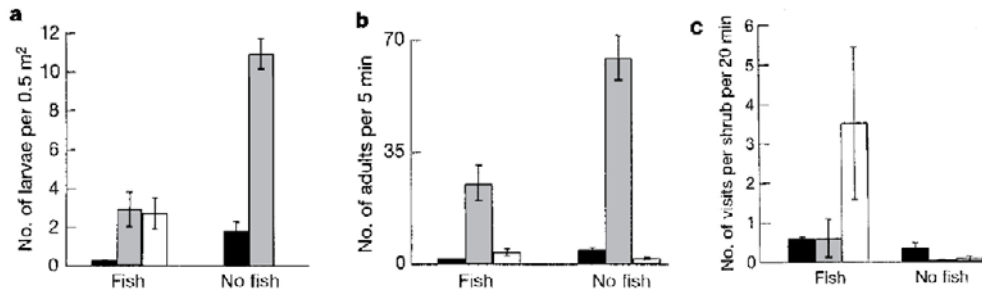
**FIG. 9.13** Mean ant abundance (percentage of occupied petiole chambers per plant), mean folivory (leaf area eaten per *Piper cenocladum* shrub), and mean leaf area per shrub before (0–2 months) and after (7–18 months) addition of a top predator, *Tarsobaenus* beetles, to half the shrubs. Vertical bars represent 1 SE. From L. Dyer and Letourneau (1999b) with permission from the National Academy of Sciences.



**FIG. 9.14** Effects of bird and/or ant exclusion on total herbivore density and composition (pie charts) in ponderosa pine canopies. Herbivore densities (means  $\pm$  SE) are for six post-treatment months. Means with different letters differ significantly ( $P < 0.05$ ). The interaction between bird and ant effects was significant ( $P = 0.03$ ). From Mooney (2007) with permission from the Ecological Society of America.

no standard approach for delimiting a site and describing or comparing community structure has been adopted. Indices of species diversity, food web structure and functional group organization are three methods used to facilitate comparison among communities.

Species diversity has two components: richness and evenness. Richness is the number of species in community, whereas evenness is a measure of relative abundances. These two components can be represented by rank-abundance curves and by diversity indices. Geometric rank-abundance curves characterize harsh or disturbed habitats with a limited



**FIG. 9.15** Trophic cascade across aquatic–terrestrial ecosystems. a) Significantly fewer ( $P < 0.01$ ) medium (gray bars) and large (black bars), but significantly more ( $P < 0.002$ ) small (white bar), larval dragonflies were found in ponds with fish than in ponds without fish; b) significantly fewer ( $P < 0.02$ ) adult dragonflies near ponds with fish than near ponds without fish; c) significantly more ( $P < 0.02$ ) pollinator visits (black bars = Diptera, gray bars = Lepidoptera, white bars = Hymenoptera) to *Hypericum fasciculatum* near ponds with fish than near ponds without fish. Data are means  $\pm$  SEM. Reprinted by permission from Macmillan Publishers Ltd: Nature (Knight et al. 2005a).

number of adapted species and strong dominance hierarchy, whereas log normal and broken stick models characterize more stable habitats with higher species accumulation and greater evenness in abundance among species. A number of diversity indices and similarity indices have been developed to integrate richness and evenness in a variable that can be compared among community types.

Food web structure represents the network of pair-wise interactions among the species in the community. A number of food web attributes have been proposed, based on limited taxonomic resolution of insects and other arthropods. Our perspective of food web dynamics has been refined as greater resolution of arthropod taxonomy reveals networks of interactions within this diverse group.

Functional group organization reflects combinations of species on the basis of their use of resources and effects on ecological processes, regardless of taxonomic affiliation. This approach has become popular because it simplifies species diversity in an ecologically meaningful way. However, the allocation of species to functional groups is based on particular objectives and is, therefore, arbitrary to the extent that each species represents a unique combination of functional responses or effects.

The non-comparable descriptions of communities based on these three approaches, compounded by the variety of arthropod sampling techniques, each with its unique biases, has hindered comparison of community structure among habitat types. Many taxa show latitudinal gradients in abundance, with species richness increasing toward the equator. However, the climate gradient thought to underlie this trend is correlated with latitudinal gradients in habitat area and productivity. Some taxonomic groups are more diverse within biogeographic realms of origin or where resources have been available over longer time periods. Some functional groups are more abundant in certain biomes, e.g., pollinators in diverse tropical habitats, detritivores and wood borers in habitats with greater organic matter or wood accumulation.

Habitat area and stability, habitat and resource conditions, and species interactions are major factors that affect community structure. Habitat area affects the pool of available species and the heterogeneity of habitat conditions and resources. Habitat stability

determines the length of time available for species accumulation, assortment and species packing. Species richness generally increases with resource availability, up to a point at which the most adapted species competitively suppress other species. Species interactions often affect persistence in a particular habitat. Colonists cannot survive unless necessary resources are available. Competition, predation and mutualism also affect species directly and indirectly. Indirect effects often are at least as important as direct effects. Keystone species have effects on community structure or ecosystem processes that are disproportionate to their numbers or biomass. Keystone species include predators that focus on the most abundant prey species, thereby reducing competition among prey species and maintaining more species than would coexist in the absence of the predator. Some herbivorous insects function as keystone species by selectively reducing the abundance of dominant host species and facilitating persistence of non-hosts. Trophic cascades reflect the top-down effects of predators reducing prey abundance, thereby increasing the abundance of the trophic level supporting the prey.

This page intentionally left blank

# Community Dynamics

- I. Short-term Change in Community Structure
- II. Successional Change in Community Structure
  - A. Patterns of Succession
  - B. Factors Affecting Succession
  - C. Models of Succession
- III. Paleoecology
- IV. Diversity vs. Stability
  - A. Components of Stability
  - B. Stability of Community Variables
- V. Summary

## Temporal change in community structure on Caribbean islands

Changes in community structure occur over short or long time scales as individual species respond, according to their tolerance ranges or other attributes, to variation in environmental conditions that occur seasonally, annually and over evolutionary time. Rapid changes occur as a result of sudden disruption in habitat or resource conditions by disturbances or anthropogenic influences on global climate.

Schowalter and Ganio (2003) and Schowalter (unpublished data) sampled invertebrates seasonally over a 20 yr period (1991–2010) in tropical rainforest canopies in Puerto Rico. This forest has relatively distinct wet and dry seasons, and a number of herbivorous taxa are known to prefer young or mature foliage. However, although herbivory showed distinct peaks during wet seasons, no taxa or functional groups showed statistically significant differences in abundance between wet and dry seasons in this forest, probably due to insufficient sample size.

Annual variation in community structure was pronounced and reflected invertebrate responses to multiple hurricanes (including Hugo 1989, Georges 1998, Bertha, Hortense, Marilyn 1996, Debbie 2001) and droughts of varying intensity during this period. Five of seven species (four Coccoidea and one Mirid) and three of four functional groups (sap-suckers, predators, and detritivores) that were sufficiently abundant to analyze statistically showed significant responses to year  $\times$  tree species interaction. Coccoidea generally were most abundant during years following major hurricanes, although this was not the case for all species on all host trees, whereas detritivores were more abundant during drought years, and predators were more abundant during drought and post-hurricane years.

Successional trends were apparent during years between disturbances, although the frequency of disturbances at this site interferes with long-term trends. In general, canopy folivores and detritivores increased in abundance and sap-suckers decreased over a 3–4 yr period

(cont.)

after hurricanes, during which the forest canopy closed and ecological functions recovered (Beard et al. 2005, Drew et al. 2009).

Longer-term changes over evolutionary time can be inferred for this forest. Dominican amber provides a wealth of information on the community structure (including insects) of tropical forests on the nearby island of Hispaniola over 25 million years ago (Poinar and Poinar 1999). Extant forests on Puerto Rico and Hispaniola are similar and might be expected to have shown similar changes over time. Schowalter (unpublished data) found that the frequency distribution of insect families represented in canopy and sticky trap samples from the Puerto Rican rainforest is similar to that found in Dominican amber samples (Poinar and Poinar 1999), suggesting that the functional structure of insect assemblages in these forests has changed relatively little over at least 25 million years.

## INTRODUCTION

COMMUNITY STRUCTURE CHANGES THROUGH TIME AS THE ABUNDANCES of species change, altering the network of interactions. Short-term (e.g., seasonal or annual) changes in community structure represent responses to environmental changes that favor some species or affect interaction strength (see Chapter 8). Longer-term (e.g., successional) changes in community structure reflect changes in habitat conditions during community development on newly available or disturbed sites. Finally, changes in community structure over evolutionary time reflect responses to long-term trends in environmental conditions.

Among the major environmental issues facing governments worldwide is the effect of anthropogenic activities (e.g., altered atmospheric or aquatic chemistry, land use, species redistribution) on the composition of natural communities and the ecosystem services they provide to humans. How might changes in community structure affect the epidemiology of human diseases? How stable is community structure, and how sensitive are communities and ecosystems to changes in species composition? Our perception of communities as self-organizing entities or random assemblages has significant implications for policies to prevent species loss and for our approach to managing ecosystem resources.

As with population dynamics, the study of changes in community structure requires long periods of observation. Few studies have continued over sufficiently long time periods to evaluate many of the factors which are presumed to affect community structure. However, paleoecological evidence and studies of community recovery following disturbance have provided useful data. Research on factors which affect community structure over a range of temporal scales can enhance our understanding of the degree of stability in community structure and improve our anticipation of responses to environmental changes.

### I. SHORT-TERM CHANGE IN COMMUNITY STRUCTURE

Community structure changes over relatively short time periods. Short-term variation in community structure reflects interactions among species responding differentially to fluctuating abiotic conditions and to species interactions. Relatively few studies have measured the effects of seasonal or annual changes in arthropod communities over extended periods. However, several studies represent annual to decadal dynamics in arthropod communities.

Fluctuating weather conditions and disturbances can cause appreciable changes in arthropod community structure. Changes in precipitation patterns can elicit differential responses among arthropod species. Schowalter et al. (1999) found that particular arthropod species, as well as the entire arthropod community, associated with creosotebush, *Larrea tridentata*, in southern New Mexico showed distinct trends in abundance over an experimental gradient in precipitation volume. The abundances of several species increased with moisture availability, whereas abundances of others declined with moisture availability, and some species showed non-linear or non-significant responses. Multivariate analysis indicated distinct community structures on plants subjected to different amounts of precipitation.

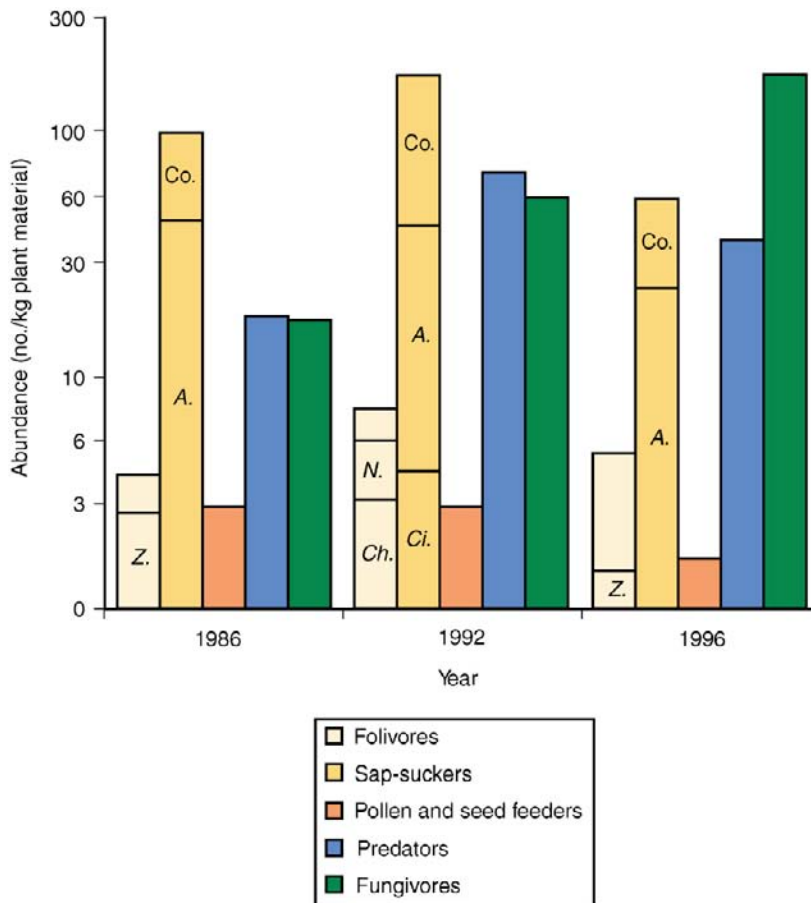
Polis et al. (1997b, 1998) studied community changes on desert islands in the Gulf of California during a 5 yr period (1990–1994) that included an El Niño event (1992–1993). Precipitation in winter 1992 was 5 times the historic mean and increased plant cover 10–160 fold. Insect abundance doubled in 1992 and 1993, compared to 1991 levels, with a significant shift in dominance from detritivores supported by marine litter to herbivores supported by increased plant biomass. Spider densities doubled in 1992 in response to prey abundance, but declined in 1993, despite continued high plant and prey abundance, due to increased abundance of parasitoid wasps, that were supported partially by nectar and pollen resources. These changes were consistent among all the islands throughout the archipelago, indicating that general processes connecting productivity and consumption governed community dynamics in this system.

Changes in precipitation pattern in western Oregon, U.S. between 1986 and 1996 altered the relative abundances of dominant folivore and sap-sucker species in conifer canopies (Fig. 10.1). In particular, the western spruce budworm, *Choristoneura occidentalis*, sawflies, *Neodiprion abietis*, and aphids, *Cinara* spp., were abundant during a drought period, 1987–1993, but virtually absent during wetter periods. A budmoth, *Zeiraphera hesperiana*, was the dominant folivore during wet years, but virtually disappeared during the drought period.

Schowalter and Ganio (2003) described changes in arthropod community structure in tropical rain forest canopies in Puerto Rico between 1991 and 1999. Hurricane Hugo (1989) created 30–50 m diameter canopy gaps that were dominated by early successional shrubs, vines, and *Cecropia schreberiana* saplings. Several species of scale insects and a phytophagous mired bug, *Itacoris* spp., were significantly more abundant on foliage in the canopy gaps, compared to non-gaps, in 1991 and again following Hurricane Georges in 1998, suggesting a positive response to storm disturbance. Scale insect and folivore abundances were significantly more abundant during a record drought (1994–95), compared to intervals between disturbances, providing further evidence of responses to disturbances.

Jonas and Joern (2007) analyzed factors that influenced changes in grasshopper assemblages over a 23-yr period (1982–2004) in North American tallgrass prairie (Fig. 10.2). Manipulated fire frequency (every 1, 4 or 20 yrs) and grazing by bison, *Bos bison*, in experimental watersheds did not affect the total abundance of grasshoppers but altered species composition, with the effect of time since the last fire being more important than that of fire frequency. Local weather conditions, including the Palmer Drought Stress Index (PDI) and North Atlantic Oscillation (NAO), best explained annual changes in species composition. Jonas and Joern (2007) concluded that the three major factors interacted in ways that minimized long-term variation in grasshopper assemblages.

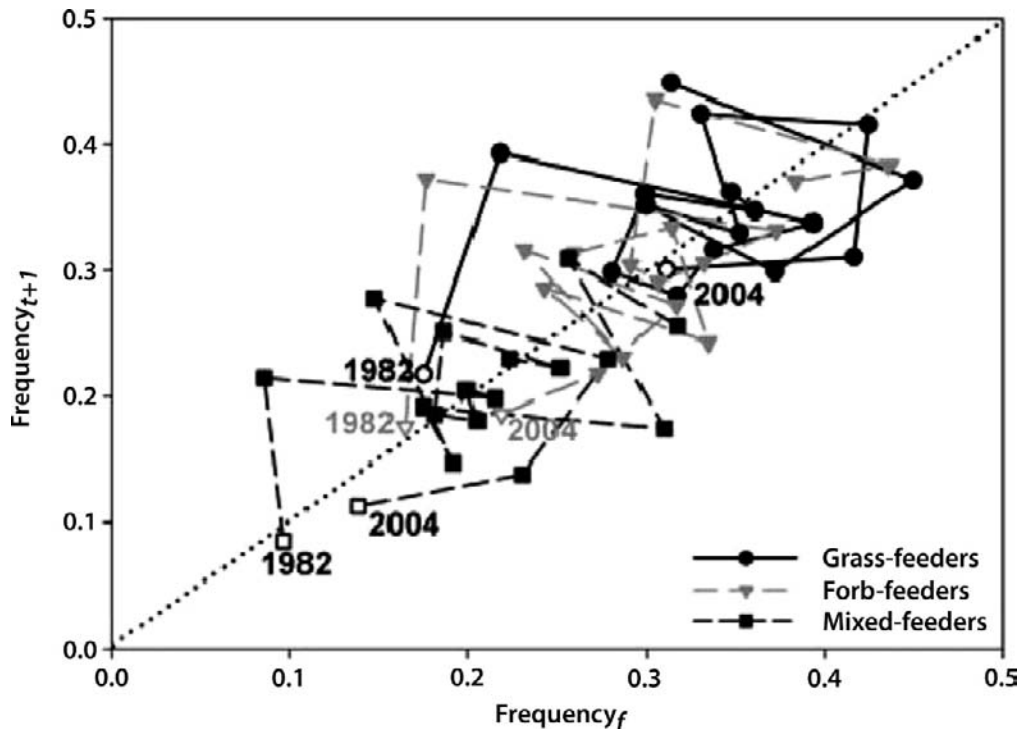




**FIG. 10.1** Temporal change in arthropod abundances in old-growth Douglas-fir canopies at the H.J. Andrews Experimental Forest in western Oregon; 1986 and 1996 were relatively wet years, 1992 was in the middle of an extended drought period (1987–1993). Z. = *Zeiraphera hesperiana*; Ch. = *Choristoneura occidentalis*; N. = *Neodiprion abietis*; Ci. = *Cinara* spp.; A. = *Adelges cooleyi*; Co. = Coccoidea (4 spp.). Note the log scale of abundance. Data from Schowalter (1989, 1995 and unpublished data).

Factors that increase competition or predation can reduce the population sizes of particular species (see Chapter 6). Some species may become locally extinct, whereas others show population irruptions. Changes in the abundance of a species affect its interactions with other species. Both the strength and direction of interaction can change greatly. Herbivores that have little effect on their hosts at low abundances can interact in a more predatory manner at high abundances (see Chapter 12). Reduced abundance of one member of a mutualism can jeopardize the persistence of the other.

Changes in species composition and abundance alter species diversity, food web structure and functional organization. Change in abundance of species at one trophic level can affect the diversity and abundance of species at lower trophic levels through trophic cascades. For example, reduced predator abundance typically increases herbivore abundance, thereby decreasing plant abundance (Carpenter and Kitchell 1987, 1988, Letourneau and Dyer 1998, see Chapter 9).



**FIG. 10.2** Changes in mean frequencies of grass-feeding, forb-feeding and mixed-feeding grasshoppers on ungrazed watersheds from 1982–2004 at Konza Prairie Biological Station (Long-Term Ecological Research Site), Kansas, with each year represented by one data point for each guild. The dotted line represents no change in frequency from year  $t$  to  $t+1$ ; points above the line represent years of increasing frequency, and points below the line represent years of decreasing frequency. For clarity, the first (1982) and last (2004) years are labeled and shown as open symbols. There are no points for 1991–1995 because samples for those years were damaged prior to identification. From Jonas and Joern (2007) with permission from the authors and with kind permission from Springer Science + Business Media.

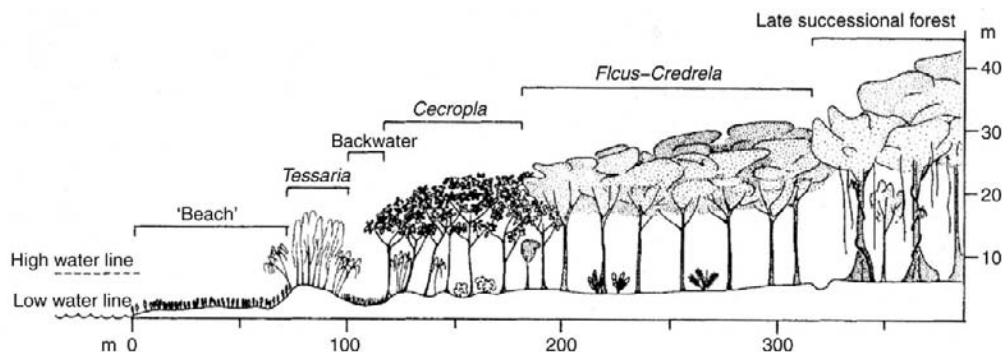
## II. SUCCESSIONAL CHANGE IN COMMUNITY STRUCTURE

Relatively predictable changes in community structure occur over periods of decades to centuries as a result of succession on newly exposed or disturbed sites. New habitats become available for colonization as a result of tectonic activity, glacial movement, sea level change, and sediment deposition or erosion. The first species to colonize newly exposed surfaces are typically small in stature, tolerant of exposure or able to exploit small shelters, and able to exploit non-organic or exogenous resources. Disturbances to existing communities will affect each species differently, depending on its particular tolerances to disturbance or post-disturbance conditions (J. Chase 2007, see Chapter 2). Benstead et al. (2007) reported that algal and fish populations returned to pre-disturbance levels within 2 yrs following the cessation of nutrient enrichment in Arctic freshwater streams. However, a dramatic and persistent increase in bryophyte mass resulting from the nutrient enrichment appeared to delay recovery of insect species that had been positively or negatively affected by the disturbance-induced shift in dominant primary producer.

Often, legacies from the pre-disturbance community (such as buried rhizomes, seed banks, woody litter, and plants and animals surviving in protected stages or microsites) remain following disturbance and influence the trajectory of community recovery (Keeton and Franklin 2005, S. Yang et al. 2008).

The process of community development on disturbed or newly exposed sites is called **ecological succession**. The succession of populations and communities on disturbed or newly exposed sites has been a unifying concept in ecology since the time of Cowles (1911) and Clements (1916). These early ecologists viewed succession as analogous to the orderly development of an organism (ontogeny). Succession progressed through a predictable sequence of stages (seres), driven by biogenic processes, that culminated in a self-perpetuating community (the climax) determined by climatic conditions. Succession is exemplified by the sequential colonization and replacement of species on abandoned cropland: weedy annual to perennial grass to forb, to shrub, to shade-intolerant tree and, finally, to shade-tolerant tree stages (E. Odum 1969). Succession on new substrates or following fire or other disturbances shows a similar sequence of stages (Salo et al. 1986, Fig. 10.3).

Although the succession of species and communities on newly exposed or disturbed sites is one of the best-documented phenomena in ecology, the nature of the community and mechanisms that drive species replacement have been debated intensely from the beginning. Gleason (1917, 1926, 1927) argued that succession is not directed by autogenic processes, but reflects the population dynamics of individual species, based on their adaptations to changing environmental conditions. Egler (1954) further argued that succession could proceed along many potential pathways, depending on initial conditions and initial species pools. E. Odum (1969) integrated the Clementsian model of succession with ecosystem processes by proposing that a number of ecosystem properties, including species diversity, primary productivity, biomass and efficiency of energy and nutrient use, increase during succession. Drury and Nisbet (1973) viewed succession as a temporal gradient in community structure, similar to the spatial gradients discussed in Chapter 9, and argued that the physiological tolerances of a species to environmental conditions were sufficient to explain species replacement. More recently, the importance of disturbances and heterotroph activity in determining successional processes and preventing ascension to the climatic climax has been recognized (e.g., Davidson 1993,



**FIG. 10.3** Diagrammatic representation of succession on new alluvial substrate in a lowland forest in the Amazon basin. From Salo et al. (1986) with permission from Macmillan Publishers Ltd: *Nature* © 1986.

MacMahon 1981, Ostfeld et al. 1997, Pickett and White 1985, Schowalter 1981, 1985, Willig and Walker 1999).

The concept of succession as being goal-oriented toward a climax has succumbed to various challenges, especially the recognition that succession can progress along various pathways to non-climatic climaxes under different environmental conditions (Whittaker 1953). Furthermore, the mechanism of species replacement is not necessarily facilitation by the community being replaced (e.g., Botkin 1981, Connell and Slatyer 1977, H. Horn 1981, McIntosh 1981, Peet and Christensen 1980, Whittaker 1953, 1970). Nevertheless, debate continues over the integrity of the community, the importance of autogenic factors that influence the process, and the degree of convergence toward particular community composition (Bazzaz 1990, Peet and Christensen 1980, Glenn-Lewin et al. 1992, West et al. 1981).

### A. Patterns of Succession

Two types of succession can be recognized. **Primary succession** occurs on newly exposed substrates, e.g., lava flows, uplifted marine deposits, dunes, newly deposited beaches, etc. Primary succession typically involves a long period of soil formation and colonization by species requiring little substrate modification. **Secondary succession** occurs on sites where the previous community was disturbed, and is influenced by remnant substrate and surviving individuals. Although most studies of succession have dealt with trends in vegetation, studies on heterotrophic successions, including successions dominated by insects or other arthropods, have contributed greatly to perspectives on the process. Insects and other arthropods dominate the development of freshwater communities and litter (especially woody litter and carrion) communities, and succession in these habitats occurs over shorter time scales than does succession involving longer-lived plant species.

Succession varies in duration, from weeks for communities with little biomass (e.g., carrion feeders) to centuries for communities with abundant biomass (e.g., forests). Shorter successions are more amenable to study by individual researchers. However, forest or desert succession spans decades to centuries and has not been studied adequately throughout its duration (Fig. 10.3). Rather, forest succession typically has been studied by selecting plots that differ in age since a disturbance or abandonment of management, to represent various seres (i.e., the chronosequence approach). Although this approach has proven convenient for comparing and contrasting various seres, it fails to account for effects of differences in initial conditions on subsequent species colonization and turnover processes (e.g., Egler 1954, Progar et al. 2000). Even Clements (1916) noted that comparing the successional stages is less informative than is evaluation of the factors that control transitions between stages. However, this approach requires that long-term plots be established and protected from confounding activities, and that research institutions commit to continuing studies beyond the usual confines of individual careers. Characterization of succession is a major goal of the network of U.S. and International Long Term Ecological Research (LTER) Sites (e.g., Van Cleve and Martin 1991). Long term and comparative studies will improve understanding of successional trajectories and their underlying mechanisms.

A number of trends have been associated with vegetation succession. Generalists or r-strategists generally dominate early successional stages, whereas specialists or K-strategists dominate later stages (Fig. 10.3) (Boyce 1984, V.K. Brown 1984, 1986, V.K. Brown and Hyman 1986, V.K. Brown and Southwood 1983, Grime 1977, Janzen 1977,

D. Strong et al. 1984, see Chapter 5). Species richness typically increases during early–mid succession but reaches a plateau or declines during late succession (Peet and Christensen 1980, Whittaker 1970). This pattern is similar to the spatial gradient that is observed in species richness across ecotones (Chapter 9).

E. Wilson (1969), based in part on data from Simberloff and Wilson (1969), suggested that community organization progresses through four stages: non-interactive, interactive, assortative, and evolutionary (see Chapter 9). The non-interactive stage occurs early during succession (first decade), when species richness and population densities are too low to induce density-dependent competition, predation or parasitism. As species number increases and densities increase, interaction strength increases and produces a temporary decline or equilibrium in species number, as some species are excluded by competition or predation. The assortative stage occurs over long disturbance-free time periods, as a result of species persistence in the community on the basis of efficient resource use and coexistence. Niche partitioning allows more species to colonize and persist. Finally, co-evolution over very long time periods increases the efficiency of interaction and permits further increase in species number. However, most communities are disturbed before reaching the assortative stage. The Intermediate Disturbance Hypothesis predicts that species richness is maximized through intermediate levels of disturbance that maintain a combination of early and late successional species (Connell 1978, Sousa 1985).

Arthropod communities also change during vegetative succession (V.K. Brown 1984, Shelford 1907, Weygoldt 1969). E. Evans (1988) found that grasshopper assemblages showed predictable changes following fire in a grassland in Kansas, U.S. The relative abundance of grass-feeding species initially increased following a fire, reflecting increased grass growth, then subsequently declined, as the abundance of forbs increased.

Schowalter (1995), Schowalter and Ganio (2003) and Schowalter et al. (1981c) reported that sap-sucking insects (primarily Hemiptera) and ants dominated early successional temperate and tropical forests, whereas folivores, predators, and detritivores dominated later successional forests. This trend probably reflects the abundance of young, succulent tissues with high translocation rates that favor sap-suckers and tending ants during early regrowth.

V.K. Brown and Southwood (1983) reported a similar trend toward increased representation of predators, scavengers and fungivores in later successional stages. They noted, in addition, that species richness of herbivorous insects and plants was highly correlated during the earliest successional stages, but not later successional stages, whereas the numbers of insects and host plants were highly correlated at later stages, but not the earliest successional stages. V.K. Brown and Southwood (1983) suggested that early colonization by herbivorous insects depends on plant species composition, but that population increases during later stages depend on the abundance of host plants (see also Chapters 6 and 7).

Punttila et al. (1994) reported that the diversity of ant species declined during forest succession in Finland. Most ant species were found in early successional stages, but only the three species of shade-tolerant ants were common in old (more than 140 yrs old) forests. They noted that forest fragmentation favored species that require open habitat, by reducing the number of forest patches with sufficient interior habitat for more shade-tolerant species.

Starzyk and Witkowski (1981) examined the relationship between bark- and wood-feeding insect communities and stages of oak–hornbeam forest succession. They found

the highest species richness in older forest (more than 70 yrs old) that contained abundant dead wood and in recent clearcuts with freshly cut stumps. Densities of mining larvae also were highest in the older forest and intermediate in the recent clearcut. Intermediate stages of forest succession supported fewer species and lower densities of bark- and wood-feeding insects. These trends reflected the decomposition of woody residues remaining during early stages and the accumulation of woody debris again during later stages.

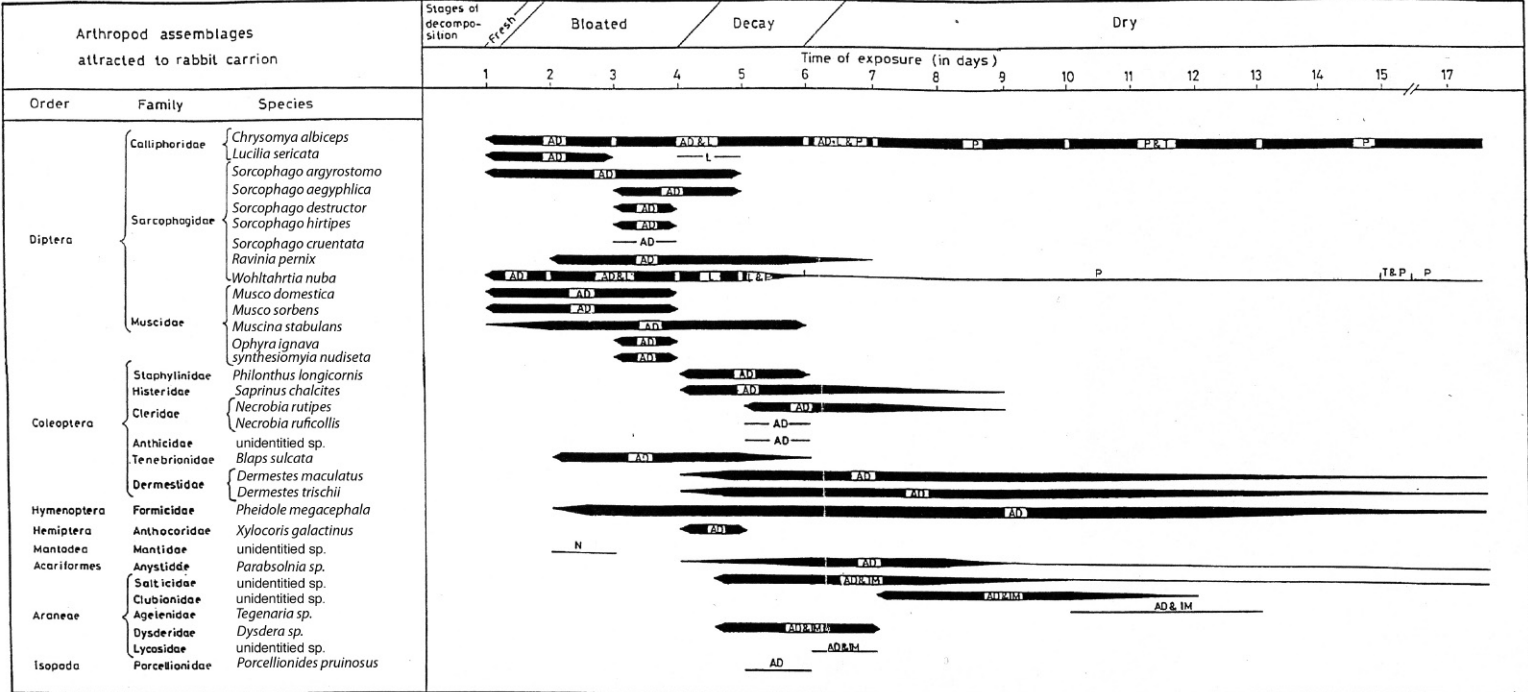
Torres (1992) reported that a sequence of Lepidoptera species appeared and reached outbreak levels on a corresponding sequence of early successional plant species, during the first six months following Hurricane Hugo (1989) in Puerto Rico, but disappeared after depleting their resources. Schowalter (unpublished data) observed this process after Hurricane Georges (1998). Davidson (1993), Schowalter (1981) and Schowalter and Lowman (1999) suggested that insect outbreaks and other animal activity may advance, retard or reverse succession by affecting plant replacement by non-host plants (see below and Chapter 12).

Heterotrophic successions also occur during plant development and in decomposing wood, animal carcasses and aquatic ecosystems. These processes can be divided into distinct stages, which are characterized by relatively discrete heterotrophic communities.

A succession of insect assemblages occurs on long-lived plants as a result of ontogenetic changes in plant physiology and morphology during growth and development. C. Fonseca et al. (2006) described the ontogenetic succession of gall-forming insects on a canopy laurel, *Cryptocarya ashersoniana*, in Brazil. Gall-former composition changed from dominance by an unidentified hymenopteran on small plants to dominance by an unidentified hemipteran on canopy trees. Hymenopteran gall density decreased 50 fold, whereas hemipteran density increased 10 fold, from small to large trees.

In general, succession in wood occurs over decadal time scales and is initiated by the penetration of the bark barrier by bark and ambrosia beetles (Scolytinae and Platypodinae) at, or shortly after, tree death (Ausmus 1977, Dowding 1984, Savely 1939, Swift 1977, Zhong and Schowalter 1989). These beetles inoculate galleries in fresh wood (decay class I, bark still intact) with a variety of symbiotic microorganisms (e.g., Stephen et al. 1993, see Chapter 8), and provide access to interior substrates for a diverse assemblage of saprotrophs and their predators. The bark and ambrosia beetles remain only for the first year, but are instrumental in penetrating bark, separating bark from wood, and facilitating drying of subcortical tissues (initiating decay class II, bark fragmented and falling off). These insects are followed by wood boring beetles, wood wasps and their associated saprophytic microorganisms that typically dominate wood for 2–10 yrs after tree death (Chapter 8). Powderpost and other beetles, carpenter ants, *Camponotus* spp., or termites dominate the later stages of wood decomposition (decay classes III–IV, extensive tunneling and decay in sapwood and heartwood, loss of structural integrity), that may persist for 5–100 yrs, depending on wood conditions (especially moisture content) and proximity to population sources. The wood becomes increasingly soft and porous, and holds more water, as decay progresses. These insects and associated bacteria and fungi complete the decomposition of wood and incorporation of recalcitrant humic materials into the forest floor (decay class V).

Insect species composition follows characteristic successional patterns in decaying carrion (Figs. 10.4 and 10.5), with distinct assemblages of species defining fresh, bloated, decay, dry, and remains stages (Payne 1965, Tantawi et al. 1996, Tullis and Goff 1987, E. Watson and Carlton 2003). For small animals, several carrion beetle species initiate the successional process by burying the carcass prior to oviposition. Distinct assemblages



**FIG. 10.4** Succession of arthropods on rabbit carrion during summer in Egypt. From Tantawi et al. (1996) with permission from the Entomological Society of America.

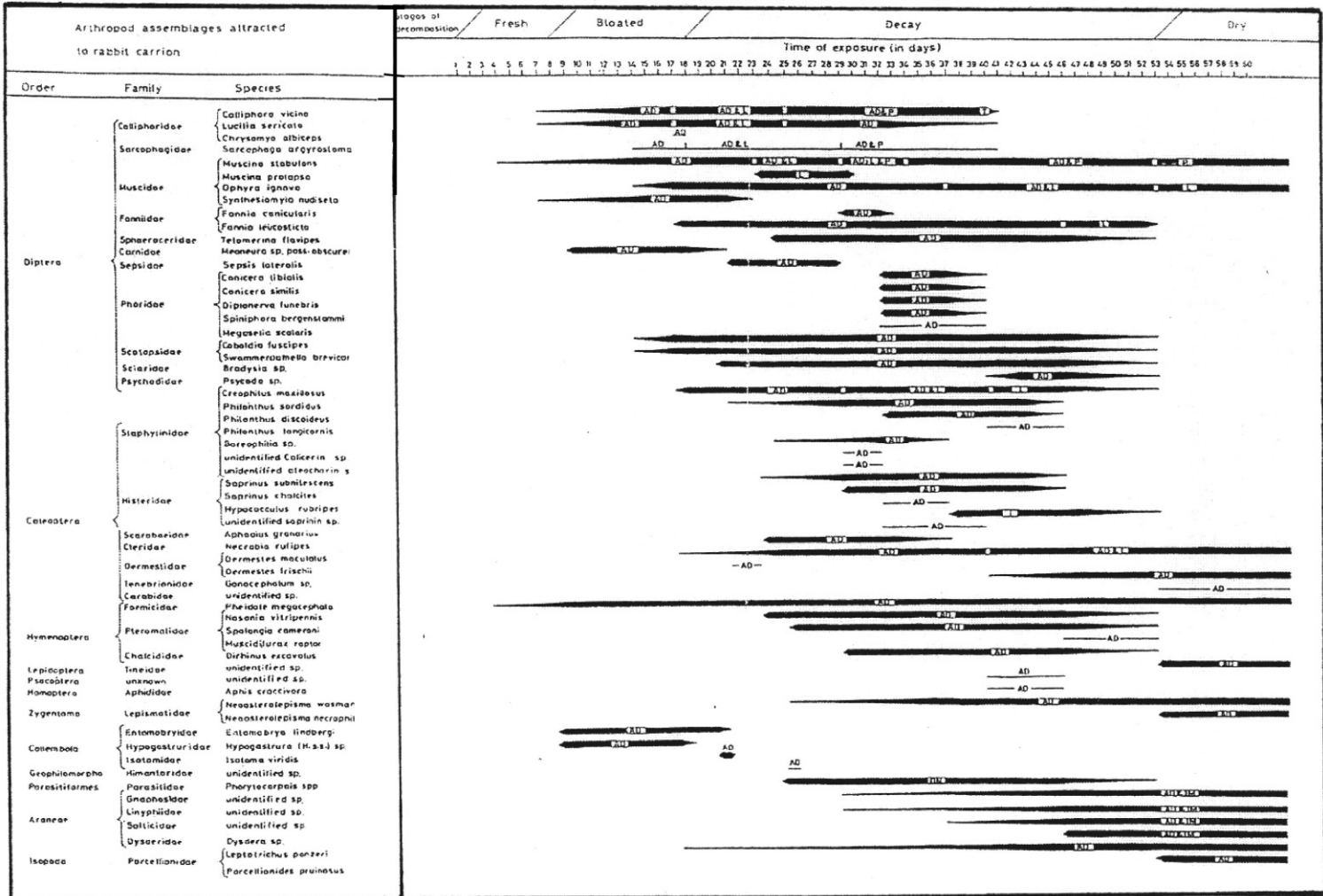


FIG. 10.5 Succession of arthropods on rabbit carrion during winter in Egypt. From Tantawi et al. (1996) with permission from the Entomological Society of America.



of insects characterize mammalian vs. reptilian carcasses (E. Watson and Carlton 2003). For all animal carcasses, the fresh, bloated and decay stages are dominated by various Diptera, especially calliphorids, whereas later stages are dominated by Coleoptera, especially dermestids. The duration of each stage depends on environmental conditions that affect the rate of decay (compare Figs. 10.4 and 10.5) (Tantawi et al. 1996) and on predators, especially ants (Tullis and Goff 1987, Wells and Greenberg 1994). This distinct sequence of necrophagous insect community types, as modified by local environmental factors, has been applied by forensic entomologists to determine time since death.

Detritus-based communities develop in bromeliad and heliconia leaf pools (phytotelmata), as well as in low-order stream systems. B. Richardson and Hull (2000) and B. Richardson et al. (2000b) observed distinct sequences of arrival of dipteran filter-feeders and gatherers during phytotelmata development in Puerto Rico. The earliest colonizer, of barely opened *Heliconia* bracts, was a small unidentified ceratopogonid, followed by an unidentified psychodid, cf. *Pericoma*. Subsequently, phytotelmata were colonized by two syrphids, *Quichuana* sp. and *Copestylum* sp. Older bracts with accumulated detritus and low oxygen concentration supported mosquitoes, *Culex antil-lummagnorum*, and finally tipulids, *Limonia* sp., in the oldest bracts. Murdock et al. (2010) reported that the timing and diversity of recolonizing consumers determined patterns of recovery in streams following drought disturbance.

## B. Factors Affecting Succession

Succession generally progresses toward the community type that is characteristic of the biome within which it occurs, e.g., toward deciduous forest within the deciduous forest biome, or toward chaparral within the chaparral biome (e.g., Whittaker 1953, 1970). However, succession can progress along various alternative pathways and reach alternative endpoints (such as stands dominated by beech, *Fagus*, maple, *Acer*, or hemlock, *Tsuga*, within the eastern deciduous forest in North America), depending on a variety of local abiotic and biotic factors. Substrate conditions represent an abiotic factor that selects a distinct subset of the regional species pool determined by climate. Distinct initial communities that reflect disturbance conditions, or unique conditions of local or regional populations, can affect the success of subsequent colonists. These initial conditions, and subsequent changes, guide succession into alternative pathways leading to distinct self-perpetuating endpoints (Egler 1954, Whittaker 1953). Herbivory and granivory are among the factors that can guide succession along alternative pathways (Blatt et al. 2001, Davidson 1993, Quesada et al. 2009).

Substrate conditions affect the ability of organisms to settle, become established, and derive necessary resources. Some substrates restrict species representation, e.g., serpentine soils, gypsum dunes, and lava flows. Relatively few species can tolerate such unique substrate conditions, or the exposure that results from limited vegetative cover. In fact, distinct subspecies often characterize the communities on these and the surrounding substrates. Contrasting communities characterize cobbled or sandy sections of streams, because of differences in exposure to water flow and infiltration of plant or detrital resources. Finally, sites with a high water table support communities that are distinct from the surrounding communities, e.g., marsh or swamp communities imbedded within grassland or forested landscapes.

Successional pathways are affected by the composition of initial colonists and survivors from the previous community. The initial colonists of a site represent regional species

pools, and their composition can vary depending on proximity to population sources. A site is more likely to be colonized by abundant species than by rare species. Rapidly growing and expanding populations are more likely to colonize even marginally suitable sites than are declining populations (see Chapter 7). For example, trees dying during a period of minimal bark beetle abundance would undergo a delay in initiation of heterotrophic succession, dominated by a different assemblage of insect species associated with different microorganisms (e.g., Stephen et al. 1993). Wood initially colonized by decay fungi, such as those inoculated by wood boring beetles, wasps and termites, decays more rapidly, thereby affecting subsequent colonization, than does wood initially colonized by mold fungi, such as those inoculated by bark and ambrosia beetles (Käärik 1974, Progar et al. 2000).

Many individuals survive disturbance, depending on their tolerance to (or protection from) disturbance, and affect subsequent succession (Egler 1954). The scale of disturbance also affects the rate of colonization. Succession that is initiated primarily by ruderal colonists will differ from succession initiated by a combination of ruderal colonists and surviving individuals and propagules, e.g., seed banks. Such legacies from the previous community contribute to the early appearance and advanced development of later successional species. These may preclude the establishment of some ruderal species that would lead along a different successional pathway. Large-scale disturbances promote ruderal species that can colonize a large area rapidly, whereas small-scale disturbances may expose too little area for shade-intolerant ruderal species, and the patch is colonized instead by later successional species expanding from the edge (Brokaw 1985, Denslow 1985, Shure and Phillips 1991). Fastie (1995) identified distance from each study site to the nearest seed source of Sitka spruce, *Picea sitchensis*, at the time of deglaciation as the major factor that explained among-site variance in spruce recruitment at Glacier Bay, Alaska.

The sequence of disturbances during succession determines the composition of successive species assemblages. For example, fire followed by drought would filter the community through a fire-tolerance sieve, then a drought-tolerance sieve, whereas flooding followed by fire would produce a different sequence of communities (e.g., J. Chase 2007). Harding et al. (1998) and Schowalter et al. (2003) demonstrated that arthropod communities in stream and forest litter, respectively, showed responses to experimental disturbances that reflected distinct community structures among blocks with different disturbance histories. Disturbance also can truncate community development. Grasslands and pine forests often dominate sites with climatic conditions that could support mesic forest, but succession is arrested by topographic or seasonal factors that increase the incidence of lightning-ignited fires and preclude persistence of mesic trees.

Longer-term environmental changes (including anthropogenic suppression of disturbances) also affect the direction of community development. J. Chase (2007) found that species assembly in experimental ponds varied considerably among replicates and appeared to be largely stochastic. However, ponds subjected to experimental drought (by slowing their draining during late summer and refilling during winter/spring) became more similar, reflecting the filtering out of species that were incapable of tolerating this disturbance. Ironically, fire suppression to “protect” natural communities often results in successional replacement of fire-dominated communities, such as pine forests and grasslands. The replacing communities may be more vulnerable to different disturbances. For example, fire suppression in the intermountain region of western North America has caused a shift in community structure from relatively open, pine woodland maintained by frequent ground fires to closed-canopy pine/fir forest that has become increasingly vulnerable to drought and stand-replacing crown fires (Agee 1993, Schowalter and Lowman 1999, Wickman 1992).

The importance of animal activity to successional transitions has not been widely recognized, despite the obvious effects of many herbivores and granivores on plant species composition (e.g., J.G. Bishop 2002, Davidson 2003, Louda et al. 1990a, Maloney and Rizzo 2002, Quesada et al. 2009, Torres 1992, see Chapter 12). Vegetation changes caused by animal activity often have been attributed to plant senescence. Animals affect succession in a variety of ways (Davidson 1993, MacMahon 1981, Schowalter and Lowman 1999, Willig and McGinley 1999), and Blatt et al. (2001) showed that incorporation of herbivory into an old-field successional model helped to explain the multiple successional pathways that could be observed. Herbivorous species can delay colonization by host species (Tyler 1995, D. Wood and Andersen 1990) and can suppress or kill host species and facilitate their replacement by non-hosts over areas as large as  $10^6$  ha during outbreaks (J.G. Bishop 2002, Schowalter and Lowman 1999). J.G. Bishop (2002) reported that insect herbivores limited the persistence and spread of early successional lupines during primary succession on Mount St. Helens following the 1980 eruption. Bullock (1991) reported that the scale of disturbance can affect animal activity, thereby influencing colonization and succession. Generally, herbivory and granivory during early seres may halt or advance succession (V.K. Brown 1984, Schowalter 1981, Torres 1992), whereas herbivory during later seres can halt or reverse succession (Davidson 1993, Schowalter and Lowman 1999). Similarly, Tullis and Goff (1987) and Wells and Greenberg (1994) reported that predaceous ants affected the colonization and activity of carrion feeders, and thereby affected the succession of the carrion community.

Granivores tend to feed on the largest seeds available, which most often represent later successional plant species, and thereby inhibit succession (Davidson 1993). Herbivores and granivores can interact competitively to affect local patterns of plant species survival and succession. For example, Ostfeld et al. (1997) reported that voles dominated interior portions of old fields, fed preferentially on hardwood seedlings over white pine, *Pinus strobus*, seedlings, and competitively displaced mice, which fed preferentially on white pine seeds over hardwood seeds near the forest edge. This interaction favored the growth of hardwood seedlings in the ecotone and favored growth of white pine seedlings in the old field interior. Other studies have shown that ants affect succession through dispersal of plant seeds and manipulation of soil and vegetation around nest sites (Q. Guo 1998, R. Inouye et al. 1980, Jonkman 1978, see Chapters 13 and 14).

Animals that construct burrows or mounds, or that wallow or compact soils can kill all vegetation in small (several square meters) patches and/or provide suitable germination habitats and other resources for ruderal plant species (D. Andersen and MacMahon 1985, MacMahon 1981, see also Chapter 14), thereby reversing succession. Several studies have demonstrated that ant and termite nests create unique habitats, typically with elevated nutrient concentrations, that support distinct vegetation when the colony is active and facilitate succession after the colony is abandoned (e.g., Brenner and Silva 1995, Garrettson et al. 1998, Q. Guo 1998, T. King 1977a, b, Lesica and Kanno 1998, Mahaney et al. 1999). Jonkman (1978) reported that the collapse of leaf-cutter ant, *Atta vollenweideri*, nests following colony abandonment provided small pools of water that facilitated plant colonization and accelerated development of woodlands in South American grasslands.

Predators also can affect succession. Hodkinson et al. (2001) observed that spiders often are the earliest colonizers of glacial moraine or other newly exposed habitats. Spider webs trap living and dead prey and other organic debris. In systems with low organic matter, nutrient availability, and microbial decomposer activity, spider digestion of prey may accelerate nutrient incorporation into the developing ecosystem. Spider

webs are composed of structural proteins and may distribute nitrogen over the surface. In addition, webs may physically stabilize the surface and increase surface moisture through condensation from the atmosphere. These effects of spiders may facilitate development of cyanobacterial crusts and early successional vegetation.

Relatively few studies have tested community development hypotheses experimentally. Patterns of arthropod colonization of new habitats represent a relatively short-term succession that is amenable to analysis. D. Strong et al. (1984) considered the unwitting movement of plants around the world by humans as representing a natural experiment for testing hypotheses about development of phytophage assemblages on a new resource. They noted that relatively few arthropod colonists on exotic plants were associated with the plant in its native habitat. Most are new recruits derived from the native fauna of the new habitat. Most of the insects that colonize introduced plants are generalists that feed on a wide range of hosts, often unrelated to the introduced plant species, and most are external folivores and sap-suckers (Kogan 1981, D. Strong et al. 1984). Miners and gall-formers represent higher proportions of the associated fauna in the region of plant origin, probably because of the higher degree of specialization that is required for feeding internally. For example, endophages represented 10–30% of the phytophages associated with two species of thistles in native European communities, but represented only 1–5% of phytophages associated with these thistles in southern California, where they were introduced (D. Strong et al. 1984). These results indicate that generalists are better colonists than are specialists, but adaptation over ecological time increases exploitation efficiency (Kogan 1981, D. Strong et al. 1984).

In one of the most ambitious studies of community development, Simberloff and Wilson (Simberloff 1969, Simberloff and Wilson 1969, E. Wilson and Simberloff 1969) defaunated (using methyl bromide fumigation) six small mangrove islands formed by *Rhizophora mangle* in Florida Bay and monitored the reestablishment of the arthropod community during the following year. Simberloff and Wilson (1969) reported that by 250 d after defaunation, all but the most distant island had species richness and composition that was similar to those of untreated islands, but densities were lower on treated islands. Initial colonists included both strong and weak fliers, but weak fliers, especially psocopterans, showed most rapid population growth. Ants, which dominated the mangrove fauna, were among the later colonists, but showed the highest consistency in colonization among islands. Simberloff and Wilson (1969) found that colonization rates for ant species were related to island size and distance from population sources. The ability of an ant species to colonize progressively smaller islands was similar to its ability to colonize increasingly distant islands. Species richness initially increased, then declined gradually as densities and interactions increased, finally reaching a dynamic equilibrium with species colonization balancing extinction (see also E. Wilson 1969). Calculated species turnover rates were  $> 0.67$  species per day (Simberloff and Wilson 1969), consistent with the model of MacArthur and Wilson (1967).

These studies explain why early successional stages are dominated by r-selected species with wide tolerances (generalists) and rapid reproductive rates, whereas later stages are dominated by K-selected species with narrower tolerances, but adapted for coexistence with more specialized species (see Chapter 5). The first arthropods to appear on newly exposed or denuded sites (also glaciated sites) typically are generalized detritivores and predators that exploit residual or exogenous dead organic material, and dying colonists unable to survive. These arthropods feed on less toxic material than do herbivores, or on material in which the defensive compounds have decayed. Herbivores can reappear

only after their host plants become established, and specialized predators similarly appear after their prey appear.

### C. Models of Succession

Clements (1916) noted that the comparison of successional stages is less useful than is an understanding of the processes that affect the transitions from one sere to another. Nevertheless, few studies have continued over periods sufficient to evaluate the mechanism(s) that produce successional transitions. Rather, a number of non-mutually-exclusive models, all of which may affect particular transitions to varying degrees, have been proposed and debated widely (e.g., Connell and Slatyer 1977, Horn 1981, McIntosh 1981, Peet and Christensen 1980). The debate involves competing views of succession as reflecting two distinct contrasts: a) resulting from either population dynamics or emergent ecosystem processes and b) resulting from stochastic assembly or converging on equilibrium community structure (Horn 1981, McIntosh 1981).

The **facilitation model** was proposed by Clements (1916), who viewed communities as an entity that showed progressive (facilitated) development similar to the ontogeny of individual organisms. According to this model, also called **relay floristics** (Egler 1954), successive stages cause progressive changes in environmental conditions that facilitate their replacement by the subsequent stage, and later successional species cannot appear until sufficient environmental modification by earlier stages has occurred. For example, soil development or increased plant density during early stages makes the environment less suitable for the recruitment of additional early, r-selected species, but more suitable for recruitment of later, K-selected species. Fire-dominated ecosystems (in which nitrogen is volatilized during fire) typically are colonized following fire by symbiotic nitrogen fixers such as alders, *Alnus* spp., ceanothus, *Ceanothus* spp., or cherries, *Prunus* spp. These species are relatively shade intolerant, and increasing density eventually suppresses their photosynthesis and nitrogen-fixation, facilitating their replacement by shade-tolerant species that grow in the understory and exploit the replenished organic nitrogen in the soil (e.g., Boring et al. 1988). The increasing porosity and altered nutrient content of decomposing wood, resulting from heterotroph activity, precludes further recruitment of early successional species, e.g., bark beetles and anaerobic or microaerophilic microorganisms, and facilitates replacement by later successional wood borers and more aerobic microorganisms (e.g., Edmonds and Eglitis 1989, Zhong and Schowalter 1989).

This model was challenged early. Gleason (1917, 1926, 1927), Whittaker (1953, 1970) and, more recently, Drury and Nisbet (1973), argued that species colonization and turnover were based on life history attributes and population dynamics. Connell and Slatyer (1977), Horn (1981) and MacMahon (1981) proposed that succession could reflect multiple pathways and mechanisms.

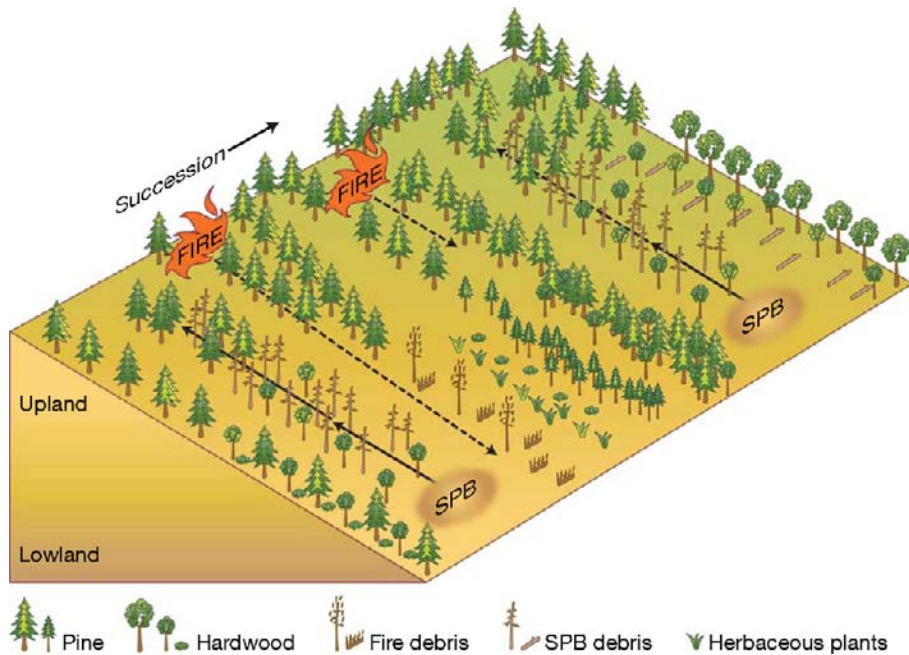
Egler (1954) argued that secondary succession often may reflect the differential longevity of colonizing species. Most of the eventual dominants colonize relatively early, while competition is still low. Failure of species to become established at this early stage reduces the probability of their future dominance. Juveniles of later species grow to maturity over a longer period, tolerating the early dominance of ruderal species, and eventually exclude the early successional species (e.g., through shading, pre-emptive use of water, etc.). Connell and Slatyer (1977) referred to this model as the **tolerance model**. This model is represented best in ecosystems that are dominated by species that sprout from roots or stumps, germinate from seed banks, or colonize rapidly from adjacent sources. These attributes

ensure early appearance along with ruderal species. However, many large-seeded trees, flightless arthropods and other animals that characterize later successional stages of forest ecosystems require a long period of establishment and achieve dominance only during late succession, especially in large areas of disturbed habitat (e.g., Shure and Phillips 1991).

A third model, proposed by Connell and Slatyer (1977) to explain at least some successional transitions, is the antithesis of facilitation. According to their **inhibition model**, the initial colonists pre-empt use of resources and exclude, suppress, or inhibit subsequent colonists for as long as these initial colonists persist. Succession can proceed only as individuals are damaged or killed, and thereby release resources (including growing space) for use by other species. Examples of inhibition are successional stages dominated by allelopathic species, such as shrubs that increase soil salinity or acidity, by species that pre-empt space, such as many perennial sod-forming grasses whose network of rhizomes restricts establishment by other plants, by species whose life spans coincide with the average interval between disturbances, and by species that create a positive feedback between disturbance and regeneration, such as eucalypts, *Eucalyptus* spp. (e.g., Shugart et al. 1981). In decomposing wood, the sequence of colonization by various insects determines initial fungal association; initial colonization by mold fungi can catabolize available labile carbohydrates and inhibit subsequent establishment by decay fungi (Käärik 1974), thus delaying further succession. Environmental fluctuation, disturbances, or animal activity (such as gopher mounds, bison wallows, trampling, and insect outbreaks) often are necessary to disrupt this bottleneck in succession (MacMahon 1981, Schowalter et al. 1981a, Schowalter and Lowman 1999). However, Agee (1993), Schowalter (1985) and Schowalter et al. (1981a) noted that bark beetle outbreaks may increase fuel accumulation and the probability of fire, perhaps ensuring the continuity of pine forest (Fig. 10.6).

Horn (1981) developed a model of forest succession as a **tree-by-tree replacement** process, that used the number of saplings of various species that were growing under each canopy species (ignoring species for which this is not a reasonable predictor of replacement), and corrected for expected longevity. This model assumes that knowing what species occupies a given position narrows the statistical range of expected future occupants, that the probability of replacement depends only on the species occupying that position, and that this probability does not change with time unless the occupant of that position changes. The model is not directly applicable to communities in which recurrent large-scale disturbances are the primary factor that affects vegetation dynamics. Interestingly, Horn (1981) found that successive iterations by a given replacement matrix gave results that invariably converged on a particular community composition, regardless of the starting composition. These results indicate that convergence is not necessarily a reflection of biotic processes (Horn 1981), and warrant increased attention to the rate of convergence and transition states that produce convergence. E. Evans (1988) reported that grasshopper assemblage structure in replicate plots in a grassland ecosystem converged (i.e., became significantly more similar than predicted by a random model) during recovery from fire (Fig. 10.7).

Many ecologists consider vegetation changes over time to be no more than expressions of life history characteristics. Species distributions in time reflect their physiological tolerances to changing environmental conditions, parallel to distributions in space (Botkin 1981, Drury and Nisbet 1973). Several major simulation models of forest gap succession are based on species-specific growth rates and longevities, as affected by stochastic mortality (e.g., T. Doyle 1981, Shugart et al. 1981, Solomon et al. 1981). Platt and Connell (2003) explored effects of relationships between early and later colonists on species replacement following catastrophic vs. non-catastrophic disturbances. These relationships

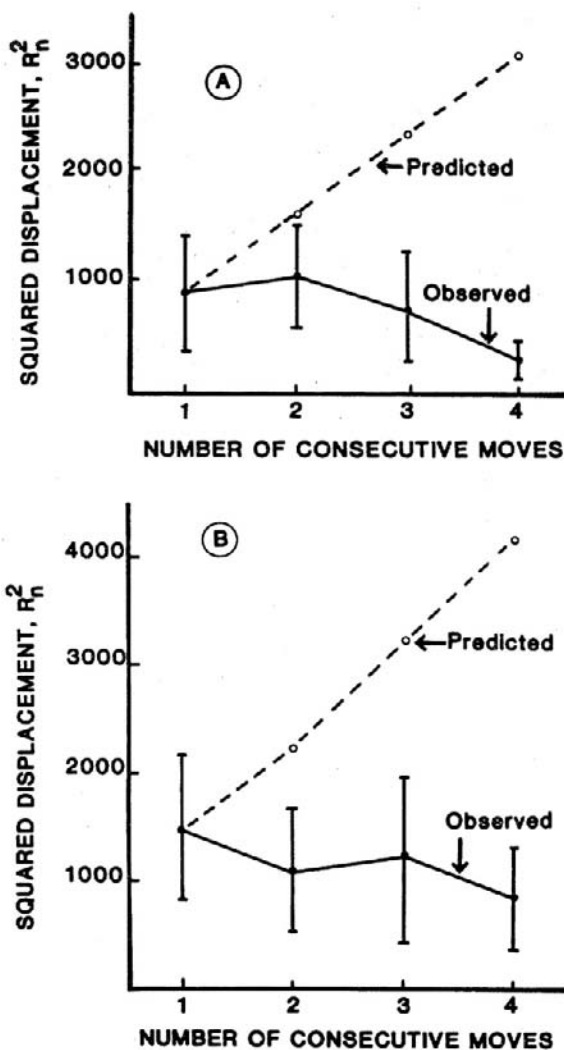


**FIG. 10.6** Diagrammatic representation of interactions between southern pine beetle and fire in the southeastern coniferous forest. Successional transitions extend from left to right; dotted arrows indicate direction of movement. Fire is a regular feature of the generally dry uplands, but moves into generally moist lowlands where drought or southern pine beetle create favorable conditions for combustion. Southern pine beetle is a regular feature of both forests, but is most abundant where pines occur at high density and stress levels. Fire is necessary for regeneration of pines, especially following succession to hardwoods if fire return is delayed. From Schowalter et al. (1981a) with permission from the Entomological Society of America.

helped to explain variable successional trajectories, depending on disturbance severity and relative survival of early and late successional species. However, Blatt et al. (2001) presented the only model that currently addresses the contribution of animals to the successional process. The variety of successional pathways determined by unique combinations of interacting initial and subsequent conditions may favor models that apply chaos theory.

### III. PALEOECOLOGY

Paleoecology provides a context for understanding the development of extant interactions and community structures. Although most paleoecological study has focused on biogeographical patterns (e.g., Price 1997), fossils can also reveal much about prehistoric species interactions and community structure (Boucot 1990, Boucot and Poinar 2010, Labandeira 1998, Labandeira and Sepkoski 1993, Poinar and Poinar 1999) and even the consequences of prehistoric changes in climate (Curran et al. 2008, Wilf and Labandeira 1999, Wilf et al. 2001) and disturbances (Labandeira et al. 2002). Similar morphological features of fossil and extant organisms imply similar functions and associated behaviors (Boucot 1990,



**FIG. 10.7** Displacement of individual grasshopper communities (A with, and B without, the unusually common *Phoetaliotes nebrascensis*) from initial ordination positions after one to four “moves” (1–4 yrs), as observed on study sites at the Konza Prairie Long Term Ecological Research Site in Kansas, U.S., 1982–1986 and as predicted by the correlated random walk model. Vertical lines represent 95% confidence limits. From E. Evans (1988) with permission from John Wiley & Sons.

Boucot and Poinar 2010, Poinar 1993, Scott and Taylor 1983), which helps to explain fossil records as well as to understand long term patterns of community change.

The fossil record contains abundant evidence of functions and behaviors that are similar to those currently observed. For example, haustellate mouthparts of proto-Hemiptera suggest an early appearance of feeding on plant sap (Labandeira and Sepkoski 1993, Scott and Taylor 1983). A fossil termite bug, *Termitaradus protera*, in Mexican amber, has the same morphological modifications as its extant congeners for surviving in termite colonies, and therefore can be assumed to have had similar interactions with termites (Poinar



1993). The dental structure of Upper Carboniferous amphibians suggests that most were predaceous, and many were insectivorous (Scott and Taylor 1983). Poinar et al. (2007) documented an example of chemical defense by a soldier beetle that was preserved in Burmese amber, at least 100 million yrs old.

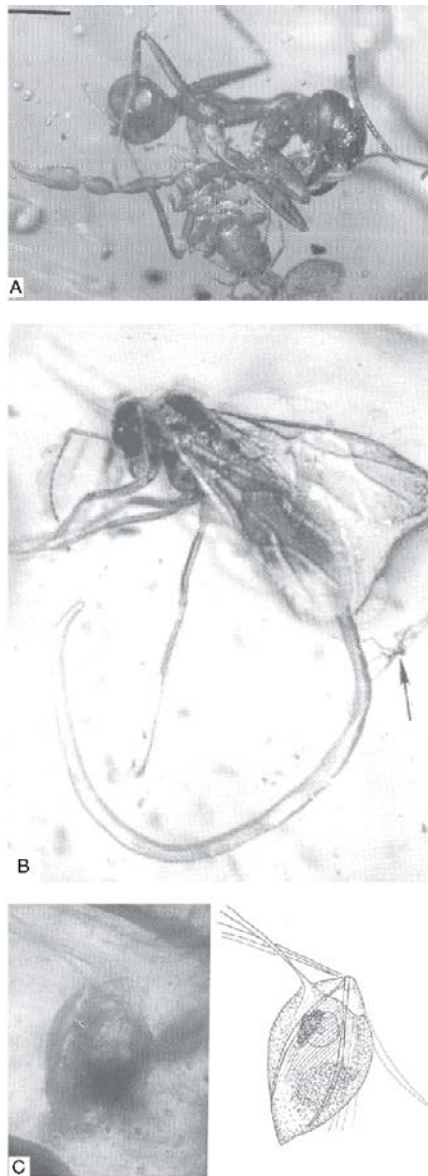
Evidence of consistent species roles suggests that host selection behaviors and other species associations within communities have been conserved over time, supporting the **Behavioral Fixity Hypothesis** (Boucot 1990, Poinar 1993, Poinar and Poinar 1999). The association of potentially interacting taxa in the same deposits and anatomical evidence of interaction are common. For example, evidence of wood boring, perhaps by ancestral beetles, can be found as early as the Upper Carboniferous (Scott and Taylor 1983). The presence of bark beetle galleries and termite nests, complete with fecal pellets, in fossil conifers from the early- to mid-Tertiary demonstrates the long evolutionary history of association between these insects and conifers (Boucot 1990, Labandeira et al. 2001). Some vertebrate coprolites from the Upper Carboniferous contain arthropod fragments (Scott and Taylor 1983). The presence of fig wasps (Agaonidae) in Dominican amber suggests co-occurrence of fig trees (Poinar 1993). Many fossil leaves from as early as the Upper Carboniferous show evidence of herbivory similar to that produced by modern insects (Boucot 1990, Currano et al. 2008, Labandeira 1998, 2002, Scott and Taylor 1983). Gut contents from arthropods in Upper Carboniferous coal deposits indicate herbivorous, fungivorous or detritivorous diets for most early arthropods (Labandeira 1998, Scott and Taylor 1983). Fossil dinosaur dung contains evidence of use by dung beetles (Poinar and Poinar 2007). Dinosaur bones often show evidence of feeding by necrophilous species (Poinar and Poinar 2007).

Demonstrated interaction between pairs or groups of particular species is uncommon (Boucot and Poinar 2010) but provides the most convincing evidence of behavioral constancy (Fig. 10.8). Evidence of competition is particularly difficult to identify in fossil remains. Poinar and Poinar (2007) suggested that herbivorous insects probably competed with herbivorous dinosaurs for plant resources, especially during prehistoric insect outbreaks.

The co-occurrence of species that interacted trophically is most likely to be preserved. Boucot (1990) reported a unique example of an extant insect species associated with extant genera in an Upper Miocene deposit in Iceland. The hickory aphid, *Longistigma caryae*, occurred in the same deposit as fossil leaves of *Carya* (or *Juglans*), *Fagus*, *Platanus*, and *Acer*. This aphid species survives on the same tree genera in eastern North America, providing strong evidence for long-term association between this insect and its hosts.

Mermithid nematodes that parasitize chironomid midges, typically castrating males and causing diagnostic changes in antennal morphology, are relatively common in Baltic and Dominican amber. Embedded male chironomids show both the altered antennal morphology and the nematode emerging at the time of host death (Boucot 1990, Poinar 1993). Parasitic mites frequently are found attached to their hosts in amber. Phoretic mites associated with their beetle or fly hosts are relatively rare (Boucot and Poinar 2010), but have been found in Dominican amber (Poinar 1993). Similarly, staphylinid beetles commensal in termite nests have been found with their termite hosts in Dominican amber (Poinar 1993).

Microbial pathogens are more difficult to detect in fossil material. Poinar and Poinar (2005) reported the inclusion of cytoplasmic polyhedrosis virus and trypanosomatids in an adult ceratopogonid biting fly and nuclear polyhedrosis virus in an adult phlebotomid



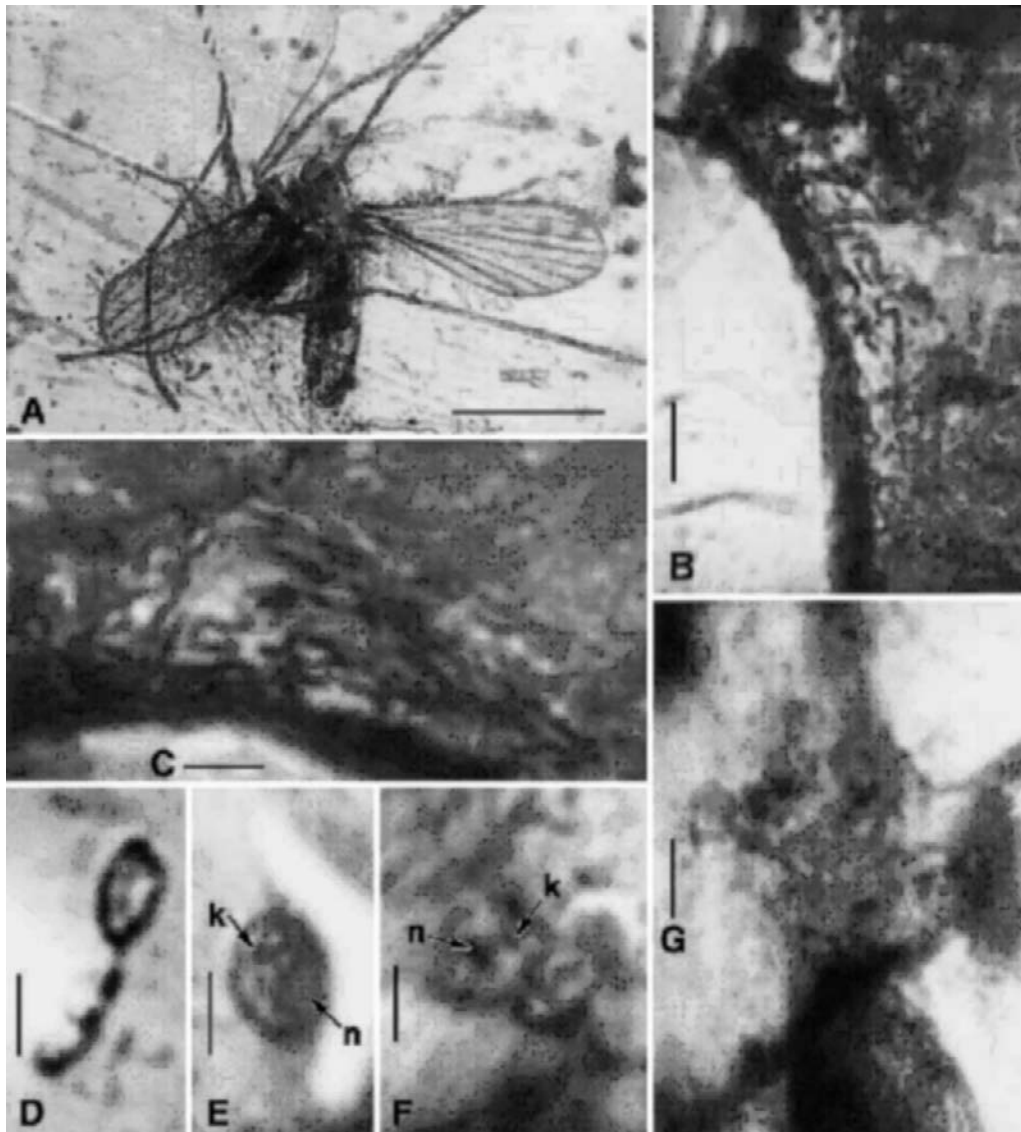
**FIG. 10.8** Fossil evidence of early interactions involving insects. A) Competitive or predaceous interaction between an ant, *Azteca alpha*, and a pseudoscorpion in Dominican amber, the ant clutching a pincher of the pseudoscorpion in its mandibles. B) A nematode, *Heydenius formicinus*, emerging from an ant, *Prenolepis henschei*, in Baltic amber; arrow points to oak trichome, indicating habitat association similar to that of extant ants of this genus. C) A protist, *Burmanymphus cretacea*, from the gut of a cockroach in Cretaceous Burmese amber; arrow indicates possible wood particle. Line drawing on right is to clarify flagella and other structures. This protist is related to mutualistic gut flagellates occurring in extant *Cryptocercus* cockroaches. A) from Poinar (2001) with permission from John Wiley & Sons, B) from Poinar (2002) © Cambridge Journals, reproduced with permission, C) Reprinted from Poinar, (2009), with permission from Elsevier.

sand fly from early Cretaceous Burmese amber, as well as several types of fungal thalli on an adult mosquito and fungal growth on a fungus gnat in Dominican amber. These fossils represent the earliest evidence of microbial infections in arthropods. Apparently, insect polyhedrosis viruses were present 100 million years ago, and those infecting biting insects may have evolved into related insect-vectored, vertebrate pathogens (Poinar and Poinar 2005).

A few examples of demonstrated mutualistic interactions are preserved in the fossil record (Boucot and Poinar 2010, Labandeira 1998, 2002). Scott and Taylor (1983) noted that spores of Upper Carboniferous plants had a resistant sporoderm capable of surviving passage through animal guts, suggesting that herbivores may have served as agents of spore dispersal. An Upper Carboniferous arthropod, *Arthropleura armata*, was found with pollen grains of a medullosan seed fern attached along its posterior edge at the base of its legs. This species could have been an early pollinator of these seed ferns, whose pollen was too large for wind transport. Furthermore, some Upper Carboniferous plants produced glandular hairs that might have been an early type of nectary to attract pollinators (Scott and Taylor 1983). An Early Cretaceous adult termite, *Kalotermes sp.*, in Burmese amber contained a variety of gut microbes, including specialized protists (Trichomonada, Hypermastigida and Oxymonada) that have mutualistic associations with modern lower termites (Boucot and Poinar 2010). Two Early Cretaceous cockroaches in Burmese amber contained protists related to mutualistic flagellates found in extant *Cryptocercus* cockroaches and lower termites (Fig. 10.8c, Boucot and Poinar 2010, Poinar 2009). These two examples represent the earliest known record of mutualism between protists and terrestrial animals. A winged queen *Brachymyrmex* ant in Dominican amber was carrying a scale insect in its mandibles (Poinar and Poinar 1994), transporting a honeydew source to its new nest site, a mutualism that persists today.

Complex, multi-species interactions are indicated by the preservation of insects which contain vectored pathogens and vertebrate blood. (Poinar 2005, Poinar and Poinar 2004b, Poinar and Telford 2005). Fossils in Dominican amber indicate the transmission of avian malaria by mosquitoes as early as the mid-Tertiary and support suggestions that some forms of primate malaria evolved in the Americas. Fossils in Burmese amber from the early Cretaceous include a female ceratopogonid midge with malarial parasites in its abdominal cavity (Poinar and Telford 2005) and a female phlebotomine sand fly, containing nucleated reptilian blood cells that were infected with leishmanial trypanosomatids, as well as leishmanial trypanosomatids in the proboscis and midgut (Fig. 10.9) (Poinar and Poinar 2004a, b). Insects apparently vectored major reptilian diseases as early as 100 million years ago, suggesting that novel, insect-vectored diseases in naïve populations of dinosaurs could have contributed to dinosaur decline and vulnerability to eventual extinction (Poinar and Poinar 2007).

Fossil data permit limited comparison of diversity and species interactions between taxonomically distinct fossil and extant communities (see also Chapter 9). Insect diversity has increased at a rate of about 1.5 families per million years since the Devonian; the rise of angiosperms during the Cretaceous Period contributed to diversification within families but did not increase the rate of diversification at the family level (Labandeira and Sepkoski 1993). Arthropod diversity was high in the communities recorded in Upper Carboniferous coal deposits and in Dominican and Mexican ambers (Poinar 1993, Poinar and Poinar 1999, Scott and Taylor 1983). Similar associations, as discussed above, indicate that virtually all types of interactions represented by extant communities (e.g.,



**FIG. 10.9** Stages in the development of *Paleoleishmania proterus* n. gen., n. sp. A) Burmese amber sand fly containing stages of *Paleoleishmania proterus* n. gen., n. sp. Bar = 540  $\mu\text{m}$ . B) promastigotes in the abdominal midgut of the fossil sand fly. Bar = 10  $\mu\text{m}$ . C) detail of promastigotes in the abdominal midgut of the fossil sand fly. Bar = 5  $\mu\text{m}$ . D) pear-shaped promastigote with nucleus and kinetoplast. Bar = 6.3  $\mu\text{m}$ . E) a single amastigote in the proboscis of the fossil sand fly. n = nucleus, k = kinetoplast. Bar = 2.2  $\mu\text{m}$ . F) two amastigotes in the proboscis of the fossil sand fly. n = nucleus, k = kinetoplast. Bar = 2  $\mu\text{m}$ . G) group of amastigotes in the proboscis of the fossil sand fly. Bar = 5  $\mu\text{m}$ . Reprinted from Poinar and Poinar, (2004a), with permission from Elsevier.

herbivore–plant, arthropod–fungus, predator–prey, pollinator, wood-borer, detritivore, etc.) were established as early as the Upper Carboniferous.

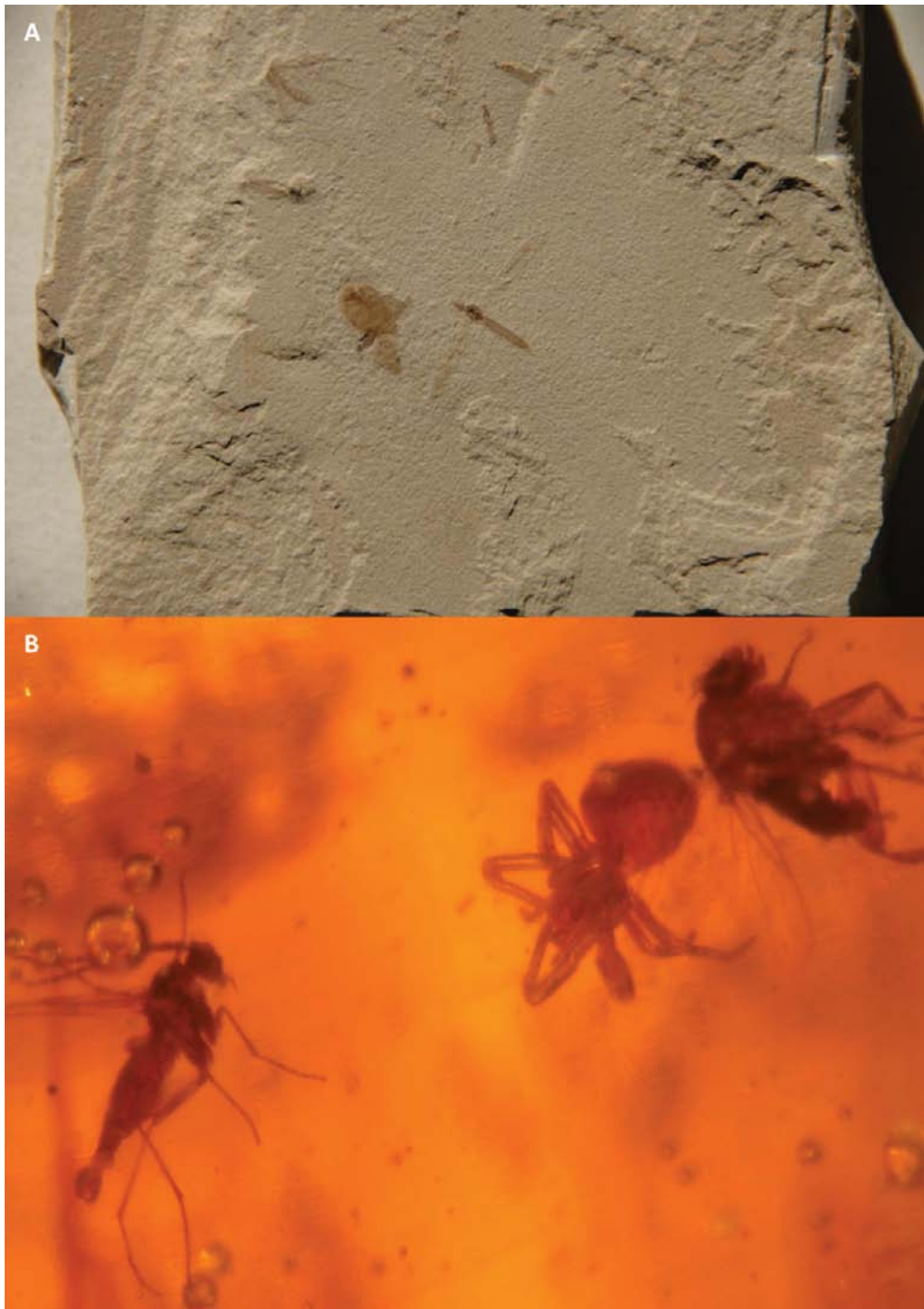
The Behavioral Fixity Hypothesis permits reconstruction of prehistoric communities, to the extent that organisms associated in coal, amber or other deposits represent prehistoric communities (e.g., Fig. 10.10) (Poinar 1993, Poinar and Poinar 1999). The Upper Carboniferous coal deposits represent a diverse, treefern-dominated, swamp ecosystem. The fossils in Dominican amber represent a tropical, evergreen, angiosperm rain forest. Some insect specimens indicate the presence of large, buttress-based, host trees, whereas other specimens indicate the presence of palms in forest openings (Poinar 1993, Poinar and Poinar 1999). The presence of fig wasps indicates that fig trees were present. Baltic amber contains a combination of warm temperate and subtropical groups, suggesting a number of possible community structures. The temperate elements could have originated at a higher elevation, or Baltic amber may have formed during a climate change from subtropical to temperate conditions (Poinar 1993). Diversity, food web structure and functional group organization were similar between these extinct communities and extant communities (Poinar 1993, Scott and Taylor 1983), suggesting that broad patterns of community structure are conserved through time, even as species composition changes (Poinar and Poinar 1999).

The fossil record can document changes in community structure at a site through time. The degree to which particular community types are continuous across discontinuities in the strata at a site indicates the consistency of environmental conditions and community structure (Boucot 1990, Labandeira et al. 2002). Boucot (1990) noted that, although a particular fossilized community (taxonomic association) rarely persists for long in a local stratigraphic section, communities typically recur over larger areas for  $10^6$ – $10^7$  yrs, indicating a high degree of stability within environmental constraints. Labandeira et al. (2002) compiled data for insect–plant associations spanning the Cretaceous–Tertiary boundary. They found that specialized (monophagous) associations almost disappeared at the boundary and have not recovered to Cretaceous levels, whereas generalized (polyphagous) associations have regained their Cretaceous abundances (Fig. 10.11). Wilf and Labandeira (1999) and Currano et al. (2008) reported that insect herbivore diversity and the intensity of herbivory increased sharply during the global warming interval from the late Paleocene to early Eocene.

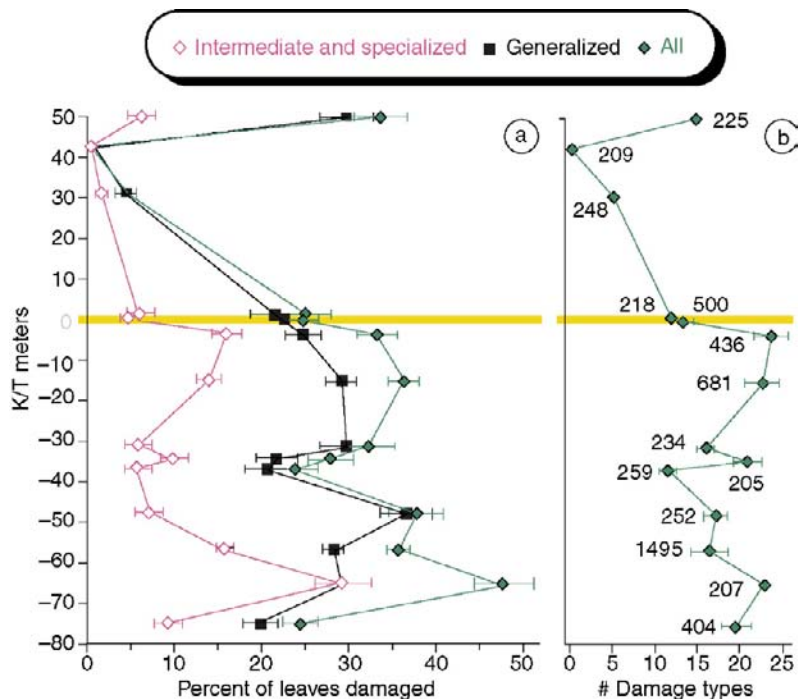
Pollen or other fossil records often indicate relatively rapid changes in the distribution of particular plant species and, presumably, of associated heterotrophs. For example, Gear and Huntley (1991) reported that dating of fossilized stumps of Scots pine, *Pinus sylvestris*, in northern Scotland indicated that pine forest expanded rapidly northward by 70–80 km about 4000 yrs ago, and persisted for about 400 yrs before retreating southward again, suggesting a 400 yr period of warmer climate and community change. However, they noted that even this remarkably rapid rate of species movement would be insufficient (by an order of magnitude) to accomplish the necessary change in range for survival under future climate change scenarios, especially if population spread were impeded by landscape fragmentation.

#### IV. DIVERSITY VS. STABILITY

The relationship between community diversity and stability remains a controversial issue (e.g., de Ruiter et al. 1995, Gonzalez and Loreau 2009, Grime 1997, Hooper and Vitousek 1997, Hooper et al. 2005, Schulze and Mooney 1993, Tilman et al. 1997, see Chapter 15). An early assumption that diversity conferred stability on communities and ecosystems



**FIG. 10.10** Fossil evidence of insect species associations. A) Tipulid and sciarid flies (Diptera) and a beetle (Coleoptera) in Eocene shale (Green River Formation, Utah). B) Sciarid and phorid flies (Diptera) and spider from a sample of Columbian amber containing > 12 species of insects (4 orders) and spiders.



**FIG. 10.11** (a) Frequency analysis (percentage) of insect damage for 14 stratigraphic horizons (with at least 200 specimens of identified dicot leaves) across the Cretaceous/Tertiary (K/T) boundary (orange bar) from the Williston Basin of southwestern North Dakota, United States. The horizontal scale is the percentage of leaves bearing insect damage (+1 S.D.). The green line represents combined damage types; the black line is generalized damage types only; the purple line is intermediate and specialized damage types. Because some individual leaves contain more than one damage type, the total percentage (green) is usually less than the sum of the two other data series. (b) Diversity analysis of insect damage, with raw data bootstrapped to 5,000 replicates. Vertical scale as in (a). The data labels show the number of leaves in each sample. Poor preservation is probably responsible for the lack of recovered insect damage around the 30- to 40-m interval. From Labandeira et al. (2002) with permission from the National Academy of Sciences.

was challenged, beginning in the 1970s, by modeling efforts that indicated increasing vulnerability to perturbation with system complexity (e.g., May 1973, 1981, Yodzis 1980). However, more recent studies have addressed the importance of diversity for maintaining ecosystem processes (e.g., de Ruiter et al. 1995, Fukami et al. 2001, Gonzalez and Loreau 2009, Tilman and Downing 1994, Tilman et al. 1997). Among these are studies of “pest” dynamics and their effects on community structure in diverse vs. simple communities (e.g., Jactel and Brockerhoff 2007).

Fundamental to our understanding of this relationship are definitions and measurements of diversity and stability (O’Neill 2001, see Chapter 15). As noted in Chapter 9, the variety of methods for measuring diversity has complicated the comparison of communities, including the assessment of community change. Should diversity be measured as species richness, functional group richness, or some diversity index using species or functional groups (de Ruiter et al. 1995, Grime 1997, Hooper and Vitousek 1997, Tilman and Downing 1994, Tilman et al. 1997)? Stability can be defined as reduced variability in system behavior. However, ecologists have disagreed over which variables are best to

measure stability. Stability has been shown to have multiple components, one representing the capacity to resist change, and the other representing the ability to recover following a change (e.g., succession): these two components indicate different degrees of stability for a given ecosystem (see below).

Traditionally, stability was measured by population and community ecologists as the constancy of species composition and community structure (e.g., Grime 1997, May 1973, 1983). Ecosystem ecologists have emphasized ecosystem processes such as primary productivity, energy flux and biogeochemical cycling, especially as variability changes during succession (e.g., de Ruiter et al. 1995, Kratz et al. 1995, E. Odum 1969, Tilman and Downing 1994). Species diversity may stabilize some variables but not others, or at one spatiotemporal scale but not another, leading to different conclusions. The extent to which diversity contributes to ecosystem integrity will be addressed in [Chapter 15](#).

### A. Components of Stability

Holling (1973) originally defined stability as the ability of a community to withstand disturbance with little change in structure, whereas resilience was defined as the capacity of the community to recover following perturbation. Webster et al. (1975) subsequently refined the definition of stability to incorporate both **resistance** to change and **resilience** following perturbation. Succession is an expression of resilience. However, the criteria for measuring stability remain elusive. What degree of change can be accommodated before resistance is breached? Does resilience require the recovery of a predisturbance community composition or of ecosystem functions that support a particular community type, and over what scale of space or time?

Webster et al. (1975) developed a functional model to evaluate the relative stability of ecosystems based on the lowest turnover rates, i.e., the longest time constraint, and damping factors (factors that reduce amplitude of fluctuation) in the system. The system has not fully recovered from displacement until the slowest component of the response has disappeared. They concluded that ecosystems with greater structure and amounts of resource storage were more resistant to disturbance, whereas ecosystems with greater turnover (e.g., via consumption and succession) were more resilient. From a community standpoint, resistance depends on the level of tolerance of the dominant species to characteristic disturbances or other environmental changes, e.g., through protected meristems or propagules, or resource storage; resilience is conferred by species with rapid recolonization and growth rates. Overall, temperate forests, with high biotic and abiotic storage and slow turnover, appear to be most resistant, but least resilient, to disturbance. Stream systems, with low biotic and abiotic storage and high turnover, appear to be least resistant, but most resilient. Resistance and resilience were found to be related inversely, with their relative contributions to stability in a given ecosystem being determined by the proportions of K- and r-specialists (see [Chapter 5](#)). Succession appears to represent a trend from more resilient to more resistant communities.

Resistance and resilience are affected by regional species abundance and distribution. Resistance can be compromised by fragmentation, which increases community exposure to external factors. For example, trees in interior forest communities are typically buffered from high temperatures and high wind speeds by surrounding trees, and they typically have less buttressing than open-grown trees. Fragmentation increases the proportion of trees that are exposed to high temperatures and wind speeds and thereby are more vulnerable to moisture stress or toppling (J. Chen et al. 1995, Franklin et al. 1992). Fragmentation also



interferes with the adapted abilities of species in the regional pool to recolonize disturbed sites. Species are adapted to levels of dispersal and colonization that are sufficient to maintain populations within the characteristic habitat matrix of the landscape. If the rate of patch turnover is increased through fragmentation, the colonization rates for many species may be insufficient to provide the necessary level of resilience for community recovery. Such changes in landscape condition may bias evaluation of community stability.

## B. Stability of Community Variables

A number of community variables can be examined from the standpoint of their variability with respect to diversity. Among these are species composition and food web structure. Simpler communities, in terms of their species composition and food web structure, often appear to be more stable than complex communities (e.g., May 1973, 1983). Boucot (1990) noted that simple marine communities in the fossil record continue across sedimentary discontinuities more often than do complex marine communities. Boucot (1990) also noted that particular taxonomic associations typically recur over larger areas for  $10^6$ – $10^7$  yrs, indicating a high degree of stability within environmental constraints. The variety of successional pathways leading to multiple endpoints (Horn 1981, Whittaker 1953) has indicated that many communities do not necessarily recover their predisturbance composition or food web structure, although some mechanisms lead to positive feedback between disturbance and community organization (Schowalter 1985, Schowalter et al. 1981a, Shugart et al. 1981).

Modeling approaches have led to contrasting conclusions. May (1973, 1983) and Yodzis (1980) reported that more complex communities were more vulnerable to disruption by perturbations in any particular species population because of their propagation through the network of interactions involving that species. However, de Ruiter et al. (1995) incorporated the patterning of interaction strengths in real communities and found that the simultaneous occurrence of strong top-down regulation of lower trophic levels and strong bottom-up regulation of higher trophic levels imposed stabilizing effects on interaction strengths. E. Evans (1988) found that grasshopper assemblages converged toward significantly greater similarity in structure following fire in a grassland ecosystem than was predicted by a random model. Fukami et al. (2001) modeled compartmentalized communities and demonstrated that increasing diversity increased similarity in composition among local communities and that greater similarity improved reliability of community structure and function.

A number of studies, especially in aquatic and grassland systems, have demonstrated that higher diversity permits compensatory responses in species composition (e.g., replacement of intolerant species by more tolerant species) that maintain ecosystem productivity, which underlies ecosystem structural and functional attributes (e.g., Gonzalez and Loreau 2009). Although Houlahan et al. (2007) reported that most studies of natural systems show positive covariances among species, rather than the negative covariances predicted by earlier compensatory dynamics models, Loreau and de Mazancourt (2008) and Gonzalez and Loreau (2009) argued that positive covariances could be consistent with compensatory dynamics when various populations in the community are inherently synchronized by strong environmental forcing and/or fluctuating abundance of a dominant species.

Diversity may dampen the spread of insects or pathogens that could threaten some species, hence disrupt community structure. For example, the diversity of pines and

hardwoods in the southern U.S. reduces spread of southern pine beetle, *Dendroctonus frontalis*, populations (Schowalter and Turchin 1993). Ostfeld and Keesing (2000) found that the number of human cases of lyme disease, caused by the tick-vectored spirochaete, *Borrelia burgdorferi*, declined with species richness of small mammals and lizards, but increased with species richness of ground-dwelling birds (Fig. 10.12). These data indicated that disease epidemiology may depend on the diversity of reservoir hosts, but disease incidence generally should decline with increasing dilution of reservoir hosts by non-hosts.

Alternatively, insects could be viewed as accelerating compensatory dynamics or providing the negative feedback that prevents unsustainable production by any particular plant species (see Chapter 15). By preferentially targeting stressed, especially dense, hosts, herbivorous insects would accelerate the replacement of intolerant species by more tolerant species, and thereby increase overall diversity.

To some extent, the lack of a clear correlation between diversity and stability of community variables may be an artifact of the duration of succession or the number of intermediate stages that can generate alternative pathways. More frequently disturbed communities may appear to be more stable than infrequently disturbed communities because a consistent group of species are selected by disturbance (e.g., J. Chase 2007), or because the ecological attributes of ruderal species favor rapid recovery, whereas longer time periods and more intervening factors affect recovery of tree species composition. Furthermore, if maximum species diversity occurs at intermediate levels of disturbance (the Intermediate Disturbance Hypothesis), then the lower species diversity of earlier and later successional communities is associated with both high and low stability, in terms of frequency and amplitude of departure from particular community structure.

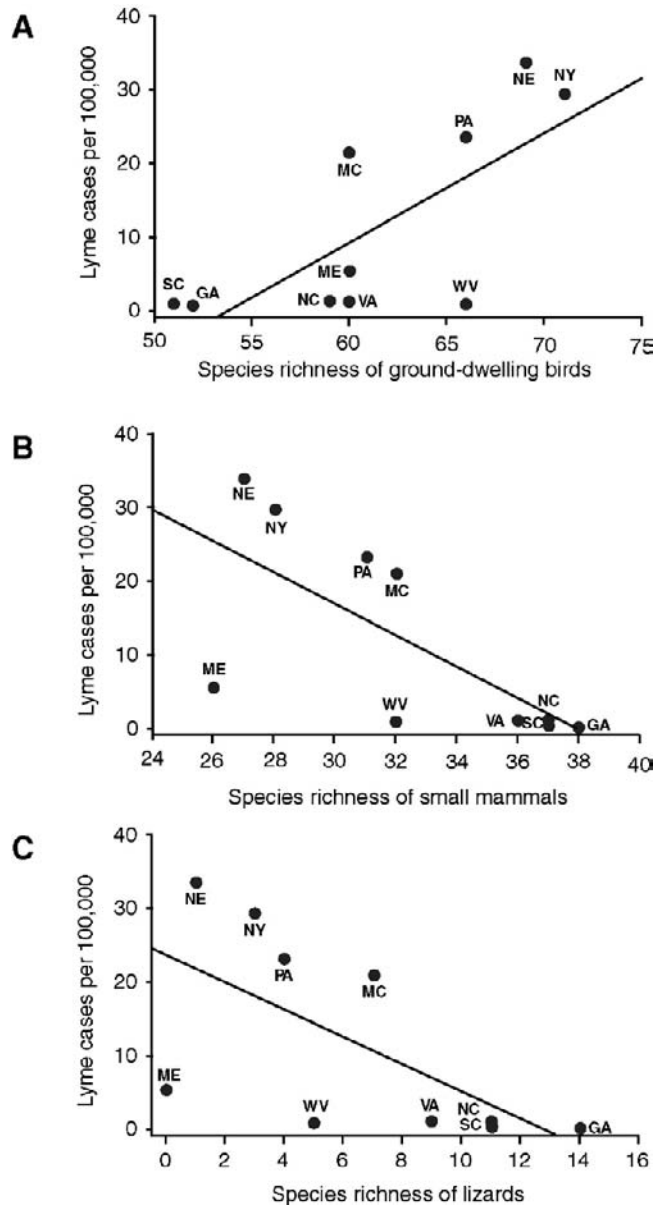
A major source of diversity is the variety of community types and the regional species pool maintained in a shifting landscape mosaic of patch types. Although the community of any particular site may appear unstable because of multiple factors interacting to affect its response to perturbation, the landscape pattern of local communities minimizes the distance between population sources and sinks and ensures proximity of colonists for species packing and assortment during site recovery. Even if the community in one patch does not recover to the same endpoint, that predisturbance endpoint is likely to appear in other patches.

## V. SUMMARY

Community structure changes over a range of time scales, from annual to decadal to millennial time periods. Temporal patterns of community organization and their sensitivity to environmental changes can indicate their stability to anthropogenic changes.

Community structure changes over short time periods as sizes of interacting populations respond to seasonal and annual variation in environmental conditions. Changes in resource quality, competition, and predation lead to population irruptions of some species and local extinction of others, thereby affecting their interactions with other species and leading to changes in community structure.

Ecological succession, the sequential stages of community development on newly exposed or disturbed sites, is one of the best documented ecological phenomena and has provided a unifying concept that integrates species life history strategies, population behavior, community dynamics and ecosystem processes. Early successional communities typically are dominated by relatively generalized ruderal species with high mobility and rapid reproductive rates. Later successional stages are increasingly dominated by species



**FIG. 10.12** Relationship between reported cases of human Lyme disease in 1996 and species richness of ground-dwelling birds A), small mammals B), and lizards C) in the eastern U.S. GA=Georgia, MC=Mid-Atlantic states, ME=Maine, NC=North Carolina, NE=New England states, NY=New York, PA=Pennsylvania, SC=South Carolina, VA=Virginia and WV=West Virginia. From Ostfeld and Keesing (2000) with permission from Johns Wiley & Sons.

that are more specialized, less mobile and have lower reproductive capacities. Although most studies of succession have focused on plants, insects show successional patterns that are associated with changes in vegetation, and the relatively rapid heterotrophic succession in decomposing wood and animal carcasses has contributed much to successional theory.

A number of factors influence successional pathways. Local substrate conditions can restrict initial colonists to those from the surrounding species pool that can become established on distinct substrates, such as serpentine, volcanic, or water-saturated soils. The composition of the initial community, including survivors of the previous disturbance and colonists, can affect the success of subsequent colonists. Subsequent disturbances and animal activity can affect successional pathways. Animals, including insects, create germination sites for colonists and suppress some host species, thereby facilitating, inhibiting, or reversing succession. In fact, animal activity often may account for vegetation changes that have been attributed to plant senescence.

Several models of succession have augmented the early view of succession as a process of facilitated community development, in which earlier stages create conditions that are more conducive to successive stages. In some cases, all the eventual dominants are present in the initial community, and succession reflects the differential development time and longevity among species, i.e., the tolerance model. Some successional stages are able to competitively exclude later colonists, the inhibition model. Succession may advance beyond such stages as a result of plant injury or death from subsequent disturbances or animal activity.

Paleoecological research indicates that species interactions and community structures have been relatively consistent over evolutionary time. However, the communities occupying particular sites have changed over these time periods as the environmental conditions of the site have changed. Recent research has provided important evidence for the evolutionary development of species interactions, including insect vectoring of vertebrate diseases.

The relationship between species or functional diversity and community or ecosystem stability has been highly controversial. Much of the discussion reflects different definitions of diversity and stability. Stability can be seen to have two major components, resistance to change and resilience following perturbation. Succession is an expression of resilience. Although much evidence indicates that the composition or structure of a particular community may not be replaced at a site, indicating instability at the local level, the structure and diversity of natural communities at a landscape scale may ensure that declining species are replaced by more tolerant species (compensatory dynamics) and that component communities are maintained within a shifting landscape mosaic, indicating stability at the landscape or regional level.

This page intentionally left blank

# ECOSYSTEM LEVEL

THE ECOSYSTEM LEVEL OF ORGANIZATION INTEGRATES species interactions and community structure with their responses to, and effects on, the abiotic environment. Interactions among organisms are the mechanism governing energy and nutrient fluxes through ecosystems. The rates and spatial patterns over which individual organisms and populations acquire and allocate energy and nutrients determine the rate and direction of these fluxes (see Chapters 4 and 8).

Communities vary in their ability to modify their abiotic environment. The relative abundance of various nutrient resources affects the efficiency with which they are cycled and retained within the ecosystem. Increasing biomass confers increased storage capacity and buffering against changes in resource availability. Community structure can also modify climatic conditions, by controlling albedo and hydric fluxes, thereby buffering individuals against changing environmental conditions.

A major issue at the ecosystem level is the extent to which communities are organized to maintain optimal conditions for the persistence of that community. Species interactions and community structures may represent adaptive attributes at the supra-organismal level that stabilize ecosystem properties near optimal levels for the various species. If so, anthropogenic interference with community organization (e.g., species redistribution, pest control, overgrazing, deforestation) may disrupt stabilizing mechanisms and contribute to ecosystem degradation.

Insects affect virtually all ecosystem properties, especially through their effects on vegetation, detritus and soils. Insects clearly affect primary productivity, hence the capture and flux of energy and nutrients. In fact, insects are the dominant pathway for energy and nutrient flow in many aquatic and terrestrial ecosystems. They affect vegetation density and porosity, hence albedo and the penetration of light, wind and precipitation, as well as the composition of plant species with varying resource demands. They affect the accumulation and decomposition of litter, and mixing and porosity of soil and litter, thereby affecting the fertility and moisture of the soil. Insects often influence disturbance frequency, succession and associated changes in efficiency of

---

ecosystem processes over time. Their small size and rapid, dramatic responses to environmental changes are ideal attributes for regulators of ecosystem processes, through positive and negative feedback mechanisms. Ironically, the effects of detritivores (largely ignored by insect ecologists) on decomposition have been emphasized by ecosystem ecologists, whereas effects of herbivorous insects (focus of insect ecologists) on ecosystem processes have been all but ignored by ecosystem ecologists until recently.

Chapter 11 summarizes key aspects of ecosystem structure and function, including energy flow, biogeochemical cycling and climate modification. Chapters 12–14 cover the variety of ways in which insects affect the structure and function of ecosystems. The varied effects of herbivores are addressed in Chapter 12. Although not often viewed from an ecosystem perspective, pollination and seed predation affect patterns of plant recruitment and primary production, as described in Chapter 13. The important effects of detritivores on organic matter turnover and soil development are the focus of Chapter 14. Finally, the potential roles of these organisms as regulators of ecosystem processes is explored in Chapter 15.

# Ecosystem Structure and Function

- I. Ecosystem Structure**
  - A. Physical Structure*
  - B. Trophic Structure*
  - C. Spatial Variability*
- II. Energy Flow**
  - A. Primary Productivity*
  - B. Secondary Productivity*
  - C. Energy Budgets*
- III. Biogeochemical Cycling**
  - A. Abiotic and Biotic Pools*
  - B. Major Cycles*
  - C. Factors Influencing Cycling Processes*
- IV. Climate Modification**
- V. Ecosystem Modeling**
- VI. Summary**

## Connecting ecosystem structure and function with global changes

Lindeman (1942) launched ecosystem research by demonstrating that the biotic and abiotic components of an aquatic ecosystem were connected inseparably by the exchange of energy and matter. Subsequent ecosystem research was largely site-specific, i.e., ecosystems were treated as ecological units with relatively discreet boundaries. Later, starting in the latter decades of the 20th century, ecosystems were compared in terms of their efficiency in retaining energy and nutrients, their ability to modify local abiotic conditions and their ability to resist or recover from disturbances.

The advent of landscape ecology and stream continuum concepts during the 1980s broadened the perspective of ecosystems to a mosaic of interconnected patches that shared a common regional species pool and exchanged individuals, energy and matter. Changes in the pattern of patch types could affect the distribution and exchange of energy and matter and alter local and regional climatic conditions. With growing public concern about effects of land-use change, climate change and invasive species, networks of long-term research sites, e.g., the U.S. Long-Term Ecological Research (LTER) Program and National Environmental Observatory Network (NEON) Program and worldwide FLUXNET, established platforms on which ecosystem responses to, and effects on, environmental changes and disturbances could be measured. Many of these sites have towers or construction cranes that permit access to

(Cont.)



the tops of forest canopies to facilitate measurement of interactions between the forest and atmosphere. New technology, such as high-resolution spectrophotometers, gas-exchange analyzers and instruments for measuring eddy-covariance, permit precise measurement of carbon and nutrient fluxes among biotic and abiotic components of ecosystems (Irvine et al. 2005, Porder et al. 2005, Treuhaft et al. 2004), while improved isotopic detection methods permit identification of sources of atmospheric gases (Aranibar et al. 2006).

The application of this technology to remote sensing techniques has revolutionized our ability to monitor changes in ecosystem conditions on a global scale. Researchers now can detect changes in local, regional and global net primary productivity (e.g., R. Waring and Running 1998, Yuan et al. 2007), net ecosystem productivity (Irvine et al. 2005, Misson et al. 2007, Treuhaft et al. 2004, D. Turner et al. 2005, Xiao et al. 2008), evapotranspiration rate (J. Zhang et al. 2009), foliage area, biomass and chemistry, especially water, lignin, nitrogen and, indirectly, phosphorus (Chambers et al. 2007, Porder et al. 2005) and drought or insect stress (Carter and Knapp 2001, Nansen et al. 2009, 2010) using hyperspectral reflectance signatures, such as from airborne visible and infrared imaging spectrometry (AVIRIS). Such data permit testing of cause-and-effect relationships between these ecosystem variables and global climate (e.g., Foley et al. 2003b, Juang et al. 2007).

We currently have an unprecedented ability to detect changes in ecosystem structure and function at local, regional and global scales. Results of large-scale studies are demonstrating ecosystem responses to, and effects on, changing climate, land use, invasive species, etc. For example, removal of overstory trees from a site greatly increases albedo and reduces the ability of the ecosystem to modify local precipitation and ameliorate the impact of torrential rain (Trenberth 1999), leading to dramatic increases in soil temperature, erosion and sedimentation of streams (e.g., J. Foley et al. 2003a). Removal of all trees or vegetation from a site exacerbates these effects (J. Foley et al. 2003b, Janssen et al. 2008). Although small-scale harvest and/or conversion of forests may appear to be relatively innocuous, extensive deforestation not only leads to regional warming and drying (Janssen et al. 2008, Juang et al. 2007, Meher-Homji 1991) but has effects far downstream in terms of the flooding of human communities and infilling of reservoirs (H. Guo et al. 2008). Furthermore, atmospheric turbulence that is generated by land cover change can increase the intensity of storms (Hossain et al. 2009, Kishtawal et al. 2010). Increasing frequency of extreme weather events is likely to have greater effects on species survival and ecosystem function, including loss of ecosystem ability to buffer climatic conditions, than will changes in average conditions (Breshears et al. 2005, Gutschick and BassiriRad 2010, Jentsch et al. 2007).

Insects have demonstrated capacity to modify environmental conditions. J.W. Moore (2006) described ways in which aquatic insects modify substrate and resource conditions. A number of herbivorous species are capable of dramatically altering vegetation structure and composition, which changes habitat conditions for associated organisms (e.g., C.G. Jones et al. 1994), often in response to ecosystem management practices (Raffa et al. 2008, see Chapter 2). This capacity of insects to alter anthropogenic design for ecosystems requires that their responses to, and effects on, ecosystem conditions be addressed in any environmental policies or management decisions.

## INTRODUCTION

TANSLEY (1935) COINED THE TERM “ECOSYSTEM” TO RECOGNIZE THE integration of the biotic community and its physical environment as a fundamental unit of ecology, within a hierarchy of physical systems that span the range from atom to universe. Shortly thereafter, Lindeman’s (1942) study of energy flow through an aquatic ecosystem introduced the modern concept of an ecosystem by demonstrating that exchange of energy and matter between biotic and abiotic pools makes a community inseparable from its environment. More recently, during the 1950s–1970s, concern over the fate of radioactive isotopes from nuclear fallout generated considerable research on biological control of elemental movement through ecosystems (Golley 1993). From the beginning, insects have been recognized as important distributors of energy and matter and as engineers of ecosystem conditions (Crossley and Howden 1961, Crossley and Witkamp 1964, Smalley 1960, Teal 1962, Witkamp and Crossley 1966). Recognition of anthropogenic effects on atmospheric conditions, especially contributions of greenhouse gas and pollutant concentrations to global warming, has renewed interest in how natural and altered communities control fluxes of energy and matter and modify abiotic conditions.

Delineation of ecosystem boundaries can be problematic. Ecosystems can be described at various scales. At one extreme, the diverse flora and fauna living on the backs of rain forest beetles (Gressitt et al. 1965, 1968) or the aquatic communities in water-holding plant structures (phytotelmata, Fig. 11.1) (B. Richardson et al. 2000a, b) constitute an ecosystem. At the other extreme, the interconnected terrestrial and marine ecosystems constitute a global ecosystem that has generated Earth’s soil and atmospheric conditions (Golley 1993, J. Lovelock 1988, Tansley 1935). Generally, ecosystems have been described at the level of the landscape patch or stream reach composed of a relatively distinct community type. However, increasing attention has been given to the interconnections among patches that compose a broader landscape-level or watershed-level ecosystem (e.g., Baxter et al. 2005, O’Neill 2001, Polis et al. 1997a, Vannote et al. 1980).

Ecosystems are characterized by their structure and function. Structure reflects the way in which the ecosystem is organized, e.g., species composition, distribution of energy and matter (biomass), and trophic or functional organization in space. Function reflects the exchanges of energy and matter among individuals and between the community and abiotic pools, and biological modification of abiotic conditions, including modification of soil and climate. This chapter describes the major structural and functional parameters of ecosystems in order to provide the basis for description of insect effects on these parameters in Chapters 12–14. Insects affect ecosystem structure and function in a number of ways and are primary pathways for energy and nutrient fluxes.

## I. ECOSYSTEM STRUCTURE

Ecosystem structure represents the various pools (both sources and sinks) of energy and matter and their relationships to each other, i.e., the directions of matter or information flow (e.g., Fig. 1.3). The size of these pools (i.e., their storage capacity) determines the buffering capacity of the system. Ecosystems can be compared on the basis of the sizes and relationships of various biotic and abiotic compartments for storage of energy and matter and on their trophic or functional group structure, biomass distribution, or spatial and temporal variability in structure.



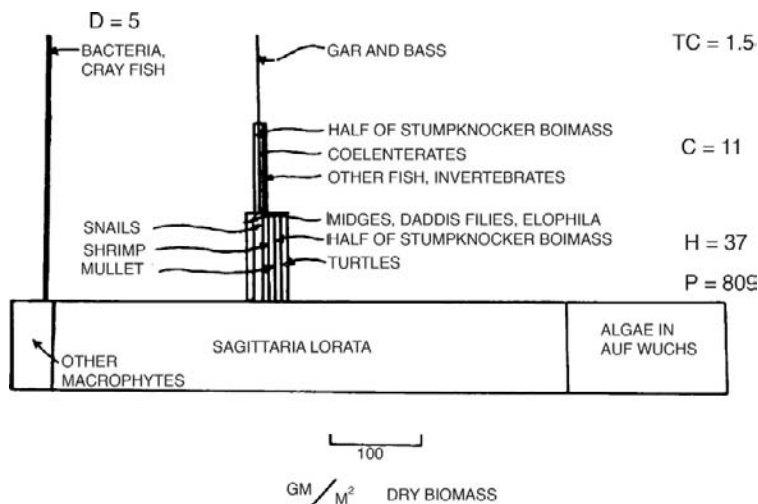
**FIG. 11.1** The community of aquatic organisms, including microflora and invertebrates, that develops in water-holding structures of plants, such as *Heliconia* flowers, represents a small-scale ecosystem with measurable inputs of energy and matter, species interactions that determine fluxes and cycling of energy and matter, and outputs of energy and matter.

## A. Physical Structure

Physical structure refers to the size and distribution of biotic and abiotic materials in the ecosystem. These variables determine direct and indirect interactions and pathways of energy and nutrient fluxes and the extent to which an ecosystem modifies climate.

The structure of some ecosystems, especially aquatic, tundra and desert systems, is dominated by abiotic materials, e.g., rocks, sediment, water or ice, that restrict the distribution and development of biotic material. The sparse biota is almost entirely exposed to changes in abiotic conditions and has relatively little capacity to modify environmental conditions.

At the other extreme, tropical and temperate rain forests are characterized by massive trees that are capable of considerable regulation of abiotic conditions, through buffering of variation in temperature, precipitation and windspeed, and extensive control of energy and nutrient exchange with abiotic pools (see below). Forest canopies shade the ground and reduce albedo, reducing diurnal and seasonal variation in temperature. Evapotranspiration directs moisture into the air, facilitating cooling, condensation and local recycling of precipitation (Trenberth 1999, Juang et al. 2007). The capacity of a forest to abate wind depends on tree structure, canopy density and wind speed. Tree structure (e.g., height, taper, rooting depth or other buttressing, wood density and branching pattern) affects sway frequency (oscillations per minute) and damping ratio (ability to return to resting position) when exposed to wind (J.R. Moore and Maguire 2005). Branch



**FIG. 11.2** Biomass pyramid for the Silver Springs ecosystem. P=primary producers, H=herbivores, C=predators, TC=top predators, D=decomposers. From H. Odum (1957) with permission from the Ecological Society of America.

and foliage density affect wind resistance. Much ecosystem energy and nutrient capital is stored in biotic pools, such as wood and litter, that are connected via food webs to buffer the ecosystem from changes in supply from abiotic pools.

## B. Trophic Structure

Trophic structure represents the various feeding levels in the community. Organisms generally can be classified as **autotrophs** (or primary producers), which synthesize organic compounds from abiotic pools, and **heterotrophs** (or secondary producers), including insects, which ultimately derive their energy and resources from autotrophs (Fig. 11.2).

Autotrophs are those organisms which are capable of fixing (acquiring and storing) inorganic resources in organic molecules. Photosynthetic plants, responsible for fixation of abiotic carbon into carbohydrates, are the primary sources of organic molecules. This chemical synthesis is powered by solar energy. Free-living and symbiotic nitrogen-fixing bacteria and cyanobacteria are an important means of converting inorganic N<sub>2</sub> into ammonia, the source of most of the nitrogen that is available to plants. Other chemoautotrophic bacteria oxidize ammonia into nitrite or nitrate (the form of nitrogen available to most green plants) or oxidize inorganic sulfur into organic compounds. Production of autotrophic tissues must be sufficient to compensate for the amounts consumed by heterotrophs.

Heterotrophs can be divided into several trophic levels depending on their source of food. Primary consumers (herbivores) eat plant tissues. Secondary consumers eat primary consumers, tertiary consumers eat secondary consumers, etc. Omnivores feed on more than one trophic level. Finally, reducers (including detritivores and decomposers) feed on dead plant and animal matter (Whittaker 1970). Detritivores fragment organic material and facilitate colonization by decomposers, which catabolize the organic compounds.

Each trophic level can be subdivided into functional groups, based on the way in which organisms gain or use resources (see Chapter 9). For example, autotrophs can be

subdivided into photosynthetic, nitrogen-fixing, nitrifying, and other functional groups. The photosynthetic functional group can be subdivided further into ruderal, competitive and stress-tolerant functional groups (e.g., Grime 1977), or into C-3 and C-4, nitrogen-accumulating, calcium accumulating, high-lignin or low-lignin functional groups, etc., to represent their different strategies for using resources and growing. Similarly, primary consumers can be subdivided into migratory grazers (e.g., many ungulates and grasshoppers), sedentary grazers (various leaf-chewing insects), leaf miners, gall-formers, sap-suckers, root feeders, parasitic plants, plant pathogens, etc., to reflect different modes for acquiring and affecting their plant resources.

The distribution of biomass in an ecosystem is an important indicator of its storage capacity, a characteristic that influences ecosystem stability (Webster et al. 1975, Chapter 15), particularly its ability to modify climate and buffer against extreme events (Jentsch et al. 2007). Harsh ecosystems, such as tundra and desert, restrict autotrophs to a relatively few, small plants with little biomass to store energy and matter. Dominant species are adapted to retain water, but water storage capacity is limited. By contrast, wetter ecosystems permit the development of large producers with greater storage capacity in their branch and root systems. Accumulated detritus represents an additional pool of stored organic matter that buffers the ecosystem from changes in resource availability. Tropical and other warm, humid ecosystems generally have relatively low detrital biomass, because of rapid decomposition and turnover. Stream and tidal ecosystems lose detrital material as a result of export in flowing water. Detritus is most likely to accumulate in cool, moist ecosystems, especially boreal forest and deep lakes, in which detritus decomposes slowly. The biomass of heterotrophs is relatively small in most terrestrial ecosystems, but may be larger than primary producer biomass in some aquatic ecosystems, as a result of high production and turnover by small biomass of algae (Whittaker 1970).

Trophic structure can be represented by numbers, mass (biomass), or energy content of organisms in each trophic level (Fig. 11.2). Such representations are called numbers pyramids, biomass pyramids, or energy pyramids (see Elton 1939) because the numbers, mass or energy content of organisms generally decrease at successively higher trophic levels. However, the form of these pyramids differs among ecosystems. Terrestrial ecosystems typically have large numbers or biomasses of primary producers that support progressively smaller numbers or biomasses of consumers. Many stream ecosystems are supported primarily by allochthonous material (detritus or prey entering from the adjacent terrestrial ecosystem) and have few primary producers (e.g., Cloe and Garman 1996, Oertli 1993, J.B. Wallace et al. 1997, Wipfli 1997). Numbers pyramids for terrestrial ecosystems may be inverted because individual plants can support numerous invertebrate consumers. Biomass pyramids for some aquatic ecosystems are inverted because a small biomass of plankton, with a high rate of reproduction and turnover, can support a larger biomass of organisms with low rates of turnover at higher trophic levels (Whittaker 1970).

### C. Spatial Variability

At one time, the ecosystem was considered to be the interacting community and abiotic conditions of a site. This view gradually has expanded to incorporate the spatial pattern of interacting component communities at a landscape or watershed level (see Chapter 9). Patches within a landscape or watershed are integrated by disturbance dynamics and they interact through the movement of organisms, energy and matter (see Chapter 7). For example, the **Stream Continuum Concept** (Vannote et al. 1980) integrates the various

stream sections that mutually influence each other. Downstream reaches are influenced by inputs from upstream, but upstream reaches are influenced by organisms returning materials from downstream (e.g., Pringle 1997, Wipfli et al. 2007). The structure of stream segments determines connectivity and may provide predator-free refugia for some species (Covich et al. 2009). Soils represent substantial storage of carbon and nutrients in some patches but may contain little carbon and nutrients in adjacent patches connected by water flux. Riparian zones (floodplains) connect terrestrial and aquatic ecosystems. Periodic flooding and emerging arthropods move sediments and nutrients from the aquatic system to the terrestrial system; runoff, falling litter and terrestrial arthropods move sediments and nutrients from the terrestrial to the aquatic system (Baxter et al. 2005, Cloe and Garman 1996, Wipfli 1997). The structure of riparian and upslope vegetation influences the interception and flow of precipitation (rain and snow) and sediment moving downhill into streams (H. Guo et al. 2008, Post and Jones 2001).

The structure of ecosystems at a stream continuum or landscape scale may have important consequences for recovery from disturbances, by affecting the proximity of population sources and sinks. Patches representing various stages of recovery from disturbance provide the sources of energy and matter (including colonists) for succession in disturbed patches. Important members of some trophic levels, especially migratory herbivores, birds, and anadromous fish, are often concentrated seasonally at particular locations along migratory routes. Social insects may forage long distances from their colonies, integrating patches through pollination, seed dispersal or other interactions. Such aggregations add spatial complexity to trophic structure.

## II. ENERGY FLOW

Life represents a balance between the tendency to increase entropy (Second Law of Thermodynamics) and the decreased entropy, through continuous energy inputs, necessary to concentrate resources for growth and reproduction. Most energy for life on Earth ultimately comes from solar radiation, which powers the chemical storage of energy through photosynthesis, though additional inputs come from chemical conversion by chemoautotrophs, e.g., in undersea volcanic vents. Given the First and Second Laws of Thermodynamics, the energy flowing through ecosystems, including resources harvested for human use, can be no greater, and typically is much less, than the amount of energy stored in carbohydrates.

Organisms have been compared to thermodynamic machines powered by the energy of carbohydrates to generate maximum power output, in terms of work and progeny (Lotka 1925, H. Odum and Pinkerton 1955, Wiegert 1968). Just as organisms can be studied in terms of their energy acquisition, allocation, and energetic efficiency (Chapter 4), so ecosystems can be studied in these terms (E. Odum 1969, H. Odum and Pinkerton 1955). Energy acquired from the sun powers the chemical synthesis of carbohydrates, which represent storage of potential energy that then is channeled through various trophic pathways, each with its own power output, and eventually is dissipated completely as heat through the combined respiration of the community (Lindeman 1942, E. Odum 1969, H. Odum and Pinkerton 1955).

The study of ecosystem energetics was pioneered by Lindeman (1942), whose model of energy flow in a lacustrine ecosystem ushered in the modern concept of the ecosystem as a thermodynamic machine. Lindeman noted that the distinction between the community of living organisms and the non-living environment is obscured by the gradual death of living

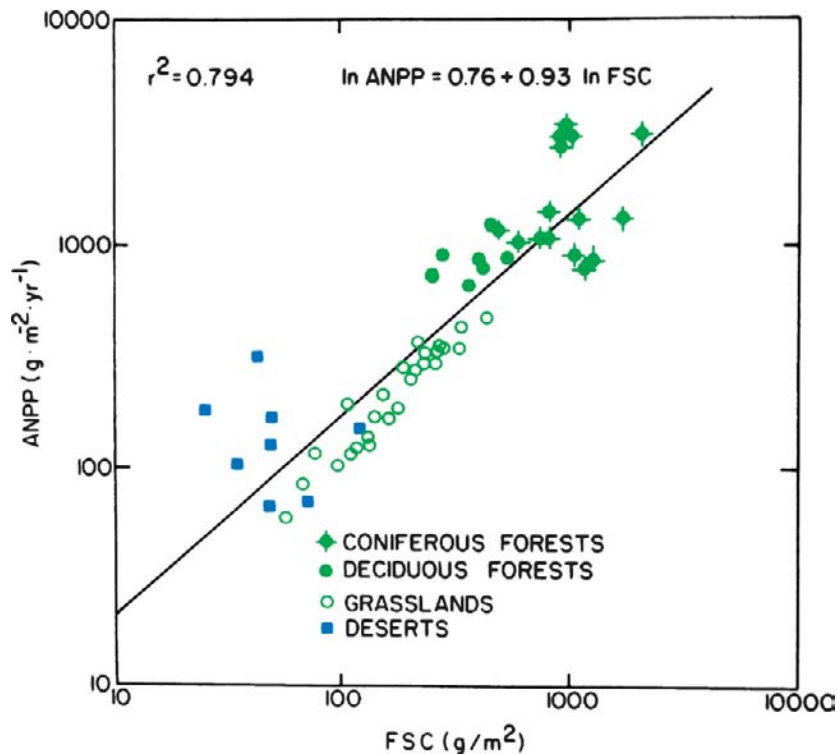
organisms and conversion of their tissues into abiotic nutrients that are reincorporated into living tissues.

The rate at which available energy is transformed into organic matter is called productivity. This energy transformation at each trophic level (as well as by each organism) represents the storage of potential energy that fuels metabolic processes and power output at each trophic level. Energy flow reflects the transfer of energy for productivity by all trophic levels.

### A. Primary Productivity

Primary productivity is the rate of conversion of solar energy into plant matter. The total rate of solar energy conversion into carbohydrates (total photosynthesis) is **gross primary productivity**. However, a portion of gross primary productivity must be expended by the plant through the metabolic processes that are necessary for maintenance, growth and reproduction, and is lost as heat through respiration. The net rate at which energy is stored as plant biomass is **net primary productivity**. The energy stored in net primary production (NPP) becomes available to heterotrophs.

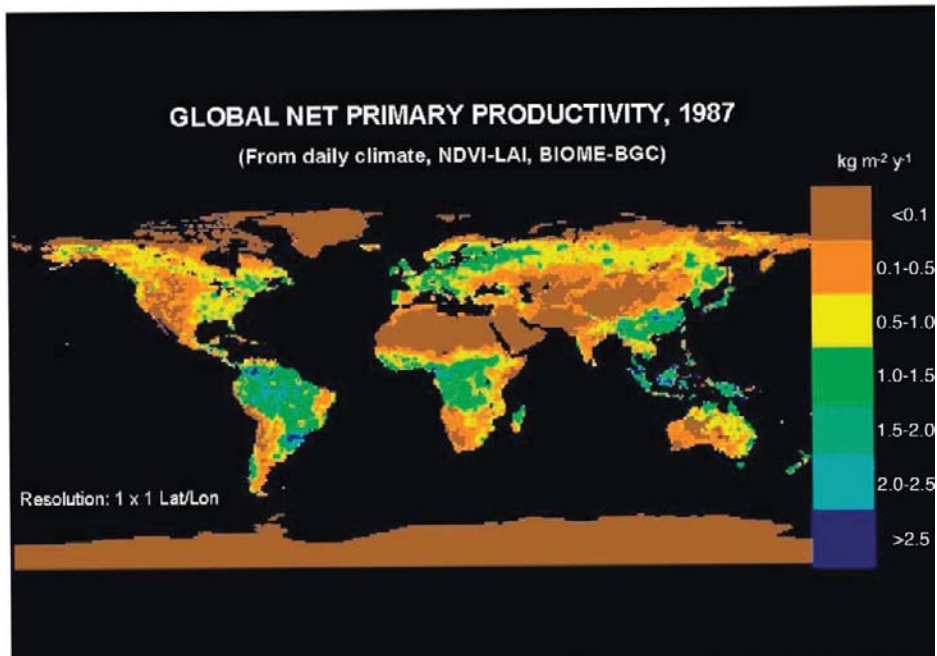
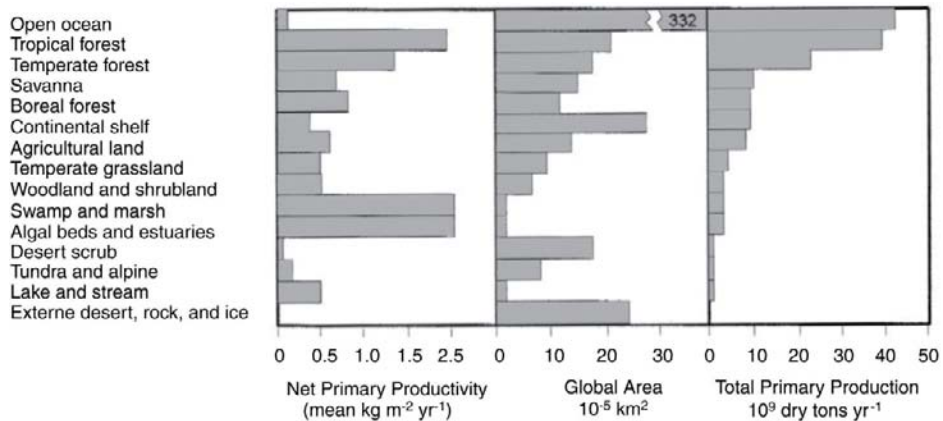
Primary productivity, turnover, and standing crop biomass are governed by a number of factors that differ among successional stages and between terrestrial and aquatic ecosystems. NPP is correlated with foliar standing crop biomass (Fig. 11.3). Hence, reduction



**FIG. 11.3** Relationship between above-ground net primary production (ANPP) and peak foliar standing crop (FSC) for forest, grassland and desert ecosystems. From W. Webb et al. (1983) with permission from the Ecological Society of America.

of foliar standing crop biomass by herbivores can affect NPP. Often, only above-ground NPP is measured, although below-ground production typically exceeds this in grassland and desert ecosystems (W. Webb et al. 1983). Among major terrestrial biomes, total (above-ground + below-ground) NPP ranges from  $< 200 \text{ g m}^{-2} \text{ yr}^{-1}$  in tundra and deserts to  $2000 \text{ g m}^{-2} \text{ yr}^{-1}$  in tropical forests, swamps and marshes, and estuaries (Fig. 11.4) (S. Brown and Lugo 1982, Waide et al. 1999, W. Webb et al. 1983, Whittaker 1970).

Photosynthetic rates and NPP are sensitive to environmental conditions. Photosynthetic rate and NPP increase with precipitation up to a point, after which they decline, due



**FIG. 11.4** Net primary production, total area, and contribution to global net primary production of the major biomes (top, data from Whittaker 1970); global calculation of total NPP using the Light Use Efficiency Model and biweekly time-integrated Normalized Difference Vegetation Index (NDVI) values for 1987. From R. Waring and Running (1998).



to low light levels associated with cloudiness and reduced nutrient availability associated with saturated soils (Schoor et al. 2001). These rates also increase with temperature, up to a point at which water loss causes stomatal closure (Whittaker 1970).

Photosynthetically-active radiation (PAR) occurs within the range 400–700 nm. The energy content of NPP divided by the supply of short-wave radiation, on an annual basis, provides a measure of photosynthetic efficiency (W. Webb et al. 1983). This efficiency generally is low, ranging from 0.065% to 1.4% for ecosystems with low to high productivities, respectively (Sims and Singh 1978, Whittaker 1970).

Photosynthetically-active radiation can be limited as a result of latitude, topography, cloud cover, or dense vegetation, which restrict the penetration of short-wave radiation. Terborgh (1985) discussed the significance of differences in tree geometries among forest biomes. Boreal tree crowns are tall and narrow to maximize their interception of lateral exposure to sunlight filtered through a greater thickness of atmosphere, whereas tropical tree crowns are umbrella-shaped to maximize interception of sunlight filtered through a thinner layer of atmosphere directly overhead. Solar penetration through tropical tree canopies, but not boreal tree canopies, is sufficient for development of multiple layers of understory plants.

The relationship between precipitation and potential evapotranspiration (PET) is an important factor affecting photosynthesis. Water limitation can result from insufficient soil water and/or precipitation, relative to evapotranspiration. Plants respond to water deficits by closing stomata, thereby reducing  $O_2$  and  $CO_2$  exchange with the atmosphere. Plants subject to frequent water deficits must solve the problem of acquiring  $CO_2$ , when stomatal opening facilitates water loss. Many desert species and tropical epiphytes are able to take up and store  $CO_2$  as malate at night (when water loss is minimal) through crassulacean acid metabolism (CAM), then carboxylate the malate (to pyruvate) and re-fix the  $CO_2$  through normal photosynthesis during the day (K. Winter and Smith 1996, Woolhouse 1981). Although CAM plants require high light levels to provide the energy for fixing the  $CO_2$  twice (Woolhouse 1981), desert plants often have high photosynthetic efficiencies relative to foliage biomass (W. Webb et al. 1983).

Air circulation is necessary to replenish  $CO_2$  within the uptake zone neighboring the leaf surface. Although atmospheric concentrations of  $CO_2$  may appear adequate, high rates of photosynthesis, especially in still air, can deplete  $CO_2$  in the boundary area around the leaf, thus reducing photosynthetic efficiency.

Ruderal plants in terrestrial ecosystems and phytoplankton in aquatic ecosystems typically have high turnover rates (short life spans) and high rates of net primary production per gram biomass, because resources are relatively non-limiting, and the plants are composed primarily of photosynthetic tissues. Net primary production by all vegetation is low, however, because of the small biomass available for photosynthesis. By contrast, later successional plant species have low turnover rates (long life spans) and lower rates of net primary production per gram, because shading reduces photosynthetic efficiency, and large portions of biomass that become necessary for support and access to sunlight are non-photosynthetic but still respire, e.g., wood and roots (e.g., Gutschick 1999).

Typically, the NPP that is consumed by herbivores on an annual basis is low, an observation that prompted Hairston et al. (1960) to conclude that herbivores are not resource limited and must be controlled by predators. However, early studies of energy content of plant material involved measurement of change in enthalpy (heat of combustion) rather than free energy (Wiegert 1968). We now know that the energy initially stored as carbohydrates is incorporated, through a number of metabolic pathways, into a

variety of compounds that vary widely in their digestibility by herbivores. The energy stored in plant compounds often costs more to digest than the free energy it provides (see Chapters 3 and 4). Many of these herbivore-detering compounds require energy expenditure by the plant, reducing the free energy available for growth and reproduction (e.g., Coley 1986). The methods used to measure herbivory often overestimate consumption but underestimate the turnover of NPP (Risley and Crossley 1993, Schowalter and Lowman 1999, see Chapter 12).

## B. Secondary Productivity

Net primary production provides the energy for all heterotrophic activity. Consumers capture the energy stored within the organic molecules of their food sources. Therefore, each trophic level acquires the energy represented by the biomass consumed from the lower trophic level. The rate of conversion of NPP into heterotroph tissues is **secondary productivity**. As with primary productivity, we can distinguish the total rate of energy consumption by secondary producers (gross secondary productivity) from the rate of energy incorporation into consumer tissues (net secondary productivity) after expenditure of energy through respiration. Secondary productivity is limited by the amount of net primary production, because only the net energy stored in plant matter is available for consumers, secondary producers cannot consume more matter than is available, and energy is lost during each transfer between trophic levels.

Not all food energy removed by consumers is ingested. Consumer feeding often is wasteful. Scraps of food are dropped, or damaged plant parts are abscised (Faeth et al. 1981, Risley and Crossley 1993), making this material available to reducers. Of the energy contained in ingested material, some is not assimilable and is egested, becoming available to reducers. A portion of assimilated energy must be used to support metabolic work, e.g., for maintenance, food acquisition, and various other activities, and is lost through respiration (see Chapter 4). The remainder is available for growth and reproduction (secondary production).

Secondary production can vary widely among heterotrophs and ecosystems. Herbivores generally have lower efficiencies of food conversion (ingestion/GPP < 10%) than do predators (< 15%) because the chemical composition of animal food is more digestible than is plant food (Whittaker 1970). Heterotherms have higher efficiencies than do homeotherms because of the greater respiratory losses associated with maintaining constant body temperature (Golley 1968, see also Chapter 4). Therefore, ecosystems dominated by invertebrates or heterothermic vertebrates (e.g., most freshwater aquatic ecosystems that are dominated by insects and fish) will have higher rates of secondary production, relative to net primary production, than will ecosystems with greater representation of homeothermic vertebrates. The annual secondary production by aquatic macroinvertebrates in streams averages 1–1000 g dry mass m<sup>-2</sup>, with the highest rates in streams dominated by filter feeders (Huryn and Wallace 2000).

Eventually, all plant and animal matter enters the detrital pool as organisms die. The energy in detritus then becomes available to reducers (detritivores and decomposers). Detritivores fragment detritus and inoculate homogenized material with microbial decomposers during gut passage. Detrital material consists primarily of lignin and cellulose, but detritivores often improve their efficiency of energy assimilation by association with gut microorganisms or by reingestion of feces (coprophagy) following microbial decay of cellulose and lignin and concentration of nitrogen and other nutrients (e.g., Breznak and Brune 1994).

### C. Energy Budgets

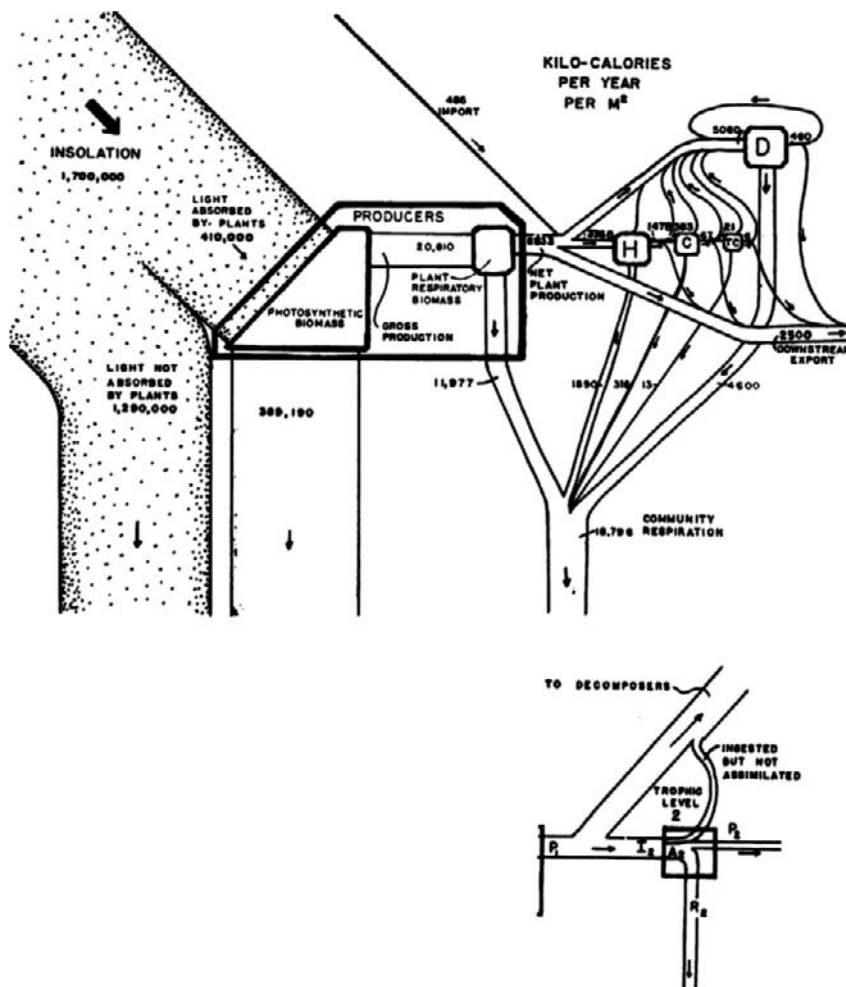
Energy budgets can be developed from measurements of available solar energy, primary productivity, secondary productivity, decomposition, and respiration. Comparison of budgets and conversion efficiencies among ecosystems can indicate factors which affect energy flow and contributions to global energy budget. Development of energy budgets for agricultural ecosystems can be used to evaluate the efficiency of human resource production.

Lindeman (1942) was the first to demonstrate that ecosystem function can be represented by energy flow through a trophic pyramid or food web. He accounted for the energy that was stored in each trophic level, transferred between each pair of trophic levels, and lost through respiration. H. Odum (1957) and Teal (1957, 1962) calculated energy storage and rates of energy flow among trophic levels in several aquatic and wetland ecosystems (Fig. 11.5). E. Odum and Smalley (1959) and Smalley (1960) calculated energy flow through consumer populations. The International Biological Programme (IBP) focused attention on the energy budgets of various ecosystems (e.g., Bormann and Likens 1979, Misra 1968, E. Odum 1969, Petruszewicz 1967, Sims and Singh 1978), including energy flow through insect populations (Kaczmarek and Wasilewski 1977, McNeill and Lawton 1970, Reichle and Crossley 1967).

More recently, the energy budgets of agricultural ecosystems have been evaluated from the standpoint of energetic efficiency and sustainability. Whereas the energy that is available to natural communities comes from the sun, additional energy inputs are necessary to maintain agricultural productivity. These include energy from fossil fuels (used to produce fertilizers and pesticides and to power machinery) and from human and animal labor (Bayliss-Smith 1990, Schroll 1994). These additional inputs of energy have been difficult to quantify (Bayliss-Smith 1990). Although the amount and value of food production is well-known, the efficiency of food production (energy content of food produced per unit of energy input) is poorly known but critical to sustainability and economic development (Patnaik and Ramakrishnan 1989). Promotion of predaceous insects to control pests, as an alternative to energy-expensive pesticides, and of soil organisms (including insects) to reduce loss of soil organic matter, as an alternative to fertilizers, has been proposed as a means to increase efficiency of agricultural production (Elliott et al. 1984, Ostrom et al. 1997, see Chapter 16).

Costanza et al. (1997), Daily (1997), N. Myers (1996) and H. Odum (1996) attempted to account for all the energy used to produce and maintain the ecosystem services that support human culture. In addition to the market and energy value of current ecosystem resources, energy was expended in the past to produce those resources. The energy inputs, over time, that produced biomass must be included in the energy budget of the system. When forests are harvested, the energy or resources that are derived from the timber can be replaced only by cumulative inputs of solar energy to replace the harvested biomass. Additional energy is expended for transportation of resources to population centers and development of societal infrastructures. Solar energy also generates tides and evaporates the water necessary for maintenance of intertidal and terrestrial ecosystems and their resources.

H. Odum (1996) proposed the term, **emergy**, to denote the total amount of energy used to produce resources and cultural infrastructures. Costanza et al. (1997), Daily (1997) and H. Odum (1996) noted that ecosystems provide a variety of “free” services (see Chapter 16), such as filtration of air and water, pollination, and fertilization of floodplains. These services are provided by energy derived from the sun and from topographic gradients and must be replaced at the cost of fossil fuel expenditure when these services are lost as a result of environmental degradation (e.g., channelization and impoundment of streams).



**FIG. 11.5** Energy flow (kcal m<sup>-2</sup> yr<sup>-1</sup>) in the Silver Springs ecosystem. H=herbivores, C=predators, TC=top predators, D=decomposers. From H. Odum (1957) with permission from the Ecological Society of America.

The sustainability of systems based on ecosystem resources thus depends on the energy derived from the ecosystem relative to the total energy required to produce the resources. Consequently, many small-scale subsistence agricultural systems are far more efficient and sustainable than are larger scale, industrial agricultural systems that could not be sustained without massive inputs from non-renewable energy sources. Unfortunately, these more sustainable agroecosystems may not provide sufficient production to feed the growing human population.

### III. BIOGEOCHEMICAL CYCLING

Organisms use the energy available to them as currency, to acquire, concentrate and organize chemical resources for growth and reproduction (Sturner and Elser 2002, see Chapter 4). Even sedentary organisms living in or on their material resources must expend energy

to acquire resources against chemical gradients or to make these resources useable (e.g., through oxidation and reduction reactions necessary for digestion and assimilation). Energy gains must be greater than energy expenditures, or resource acquisition, growth and reproduction cannot be maintained.

Energy and matter are transferred from one trophic level to the next through consumption, but whereas energy is dissipated ultimately as heat, matter is conserved and reused. Conservation and reuse of nutrients within the ecosystem buffer organisms against resource limitation and also contribute to ecosystem stability. The efficiency with which limiting elements are recycled varies among ecosystems. Biogeochemical cycling results from fluxes among biotic and abiotic storage pools.

Biogeochemical cycling occurs over a range of spatial and temporal scales. Cycling occurs within ecosystems as a result of trophic transfers and recycling of biotic materials made available through decomposition. Rapid cycling by microbial components is coupled with slower cycling by larger, longer-lived organisms within ecosystems. Nutrients that are exported from one ecosystem become inputs for another. Detritus washed into streams during storms is the primary source of nutrients for many stream ecosystems. Nutrients moving downstream are major sources for estuarine and marine ecosystems. Nutrients lost to marine sediments are returned to terrestrial pools through geologic uplifting. Materials stored in these long-term abiotic pools become available for extant ecosystems through weathering and erosion. The pathways and rates of nutrient movement can be described by ecological stoichiometry (Sterner and Elser 2002).

## A. Abiotic and Biotic Pools

The sources of all elemental nutrients necessary for life are abiotic pools, the atmosphere, oceans, and sediments. The atmosphere is the primary source of nitrogen, carbon (as carbon dioxide) and water for terrestrial ecosystems. Sediments are a major pool of carbon (as calcium carbonate), as well as the primary source of mineral elements, e.g., phosphorus, sulfur and cations such as sodium, potassium, calcium, and magnesium released through chemical weathering. The ocean is the primary source of water, but also is a major source of carbon (from carbonates) for marine organisms and of cations that enter the atmosphere when storm winds lift water and dissolved minerals from the ocean surface.

Resources from abiotic pools are not available to all organisms, but must be transformed (fixed) into biologically useful compounds by autotrophic organisms. Photosynthetic plants acquire water and atmospheric or dissolved carbon dioxide to synthesize carbohydrates, which then are stored in biomass (see above). Nitrogen-fixing bacteria and cyanobacteria acquire atmospheric or dissolved  $N_2$  and convert it into ammonia, which they and some plants can incorporate directly into amino acids and nucleic acids. Nitrifying bacteria oxidize ammonia into nitrate, the form of nitrogen that is available to most plants, and nitrite. These autotrophs also acquire other essential nutrients in dissolved form. The living and dead biomass of these organisms represents the pool of energy and nutrients available to heterotrophs.

The size of biotic pools represents storage capacity that buffers the organisms representing these pools against reduced availability of nutrients from abiotic sources. Larger organisms have a greater capacity to store energy and nutrients for use during periods of limited resource availability than do smaller organisms. Many plants can mobilize stored nutrients from tubers, rhizomes, or woody tissues in order to maintain their metabolic activity during unfavorable periods. Similarly, larger animals can store more energy, such

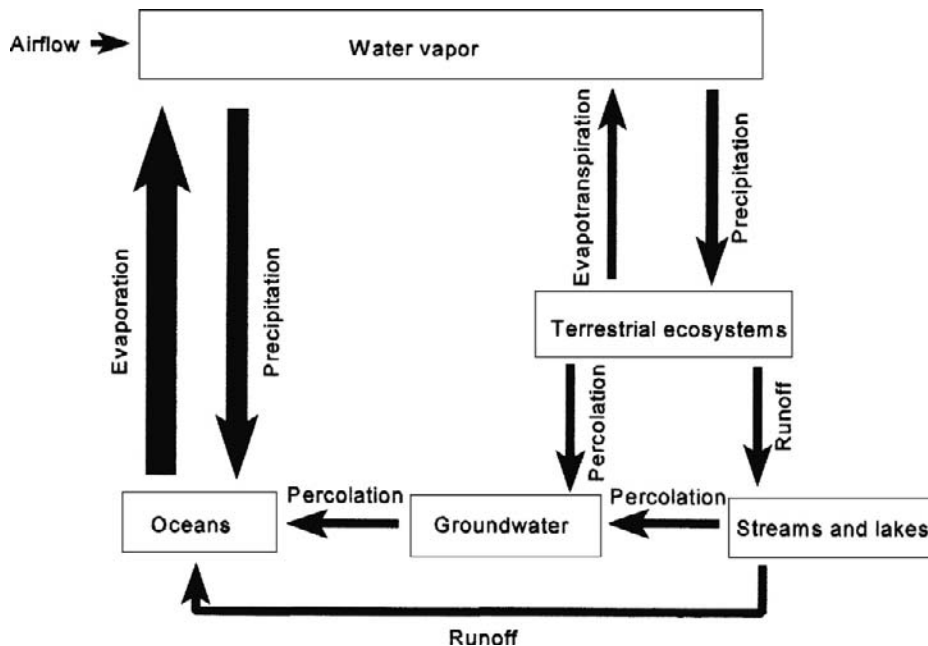
as in the fat body of insects, and can retrieve nutrients from muscle or other tissues during periods of inadequate resource acquisition. Detritus represents a major pool of organic compounds. The nutrients from detritus become available to organisms through decomposition. Ecosystems with greater nutrient storage in living or dead biomass tend to be more resistant to certain environmental changes than are ecosystems with more limited storage capacity (Webster et al. 1975).

## B. Major Cycles

The biota modifies chemical fluxes. In the absence of biota, the rate and direction of chemical fluxes would be controlled solely by the physical and chemical factors determining exchanges between abiotic pools. Chemicals would be retained at a site only to the extent that chelation or concentration gradients restricted their leaching or diffusion. Exposed nutrients would continue to move with wind or water (erosion). Biotic uptake and storage of chemical resources creates a biotic pool that alters the rates of exchange among abiotic pools and restricts the movement of nutrients across chemical and topographic gradients. For example, the uptake and storage of atmospheric  $\text{CO}_2$  by plants (including long-term storage in fossil biomass, i.e., coal, oil and gas), and the uptake and storage of calcium carbonate by marine animals (and deposition in marine sediments) control concentration gradients of  $\text{CO}_2$  available for exchange between the atmosphere and the ocean (Keeling et al. 1995, Sarmiento and Le Quéré 1996). Conversely, fossil fuel combustion, deforestation, desertification, and destruction of coral reefs is reducing  $\text{CO}_2$  uptake by biota and releasing  $\text{CO}_2$  from biotic storage, thereby increasing levels of  $\text{CO}_2$  that are available globally for exchange between the atmosphere and ocean. Biotic uptake of various sedimentary nutrients retards their transport from higher elevations back to marine sediments.

Consumers, including insects, affect the rate at which nutrients are acquired and stored (see Chapters 12–14). Consumption reduces the biomass of the lower trophic level, thereby affecting nutrient uptake and storage at that trophic level, and moves nutrients from consumed biomass into biomass at the higher trophic level (through secondary production) or into the detritus (through secretion and excretion) where nutrients become available to detritivores, soil microorganisms, or are exported via water flow to aquatic food webs. Insects themselves can constitute significant pools of nutrients, and their dispersal can represent significant redistribution (Whiles et al. 2001). Carlton and Goldman (1984) and Menninger et al. (2008) found that large numbers of ants and emergent periodical cicadas, respectively, falling into aquatic ecosystems provided sufficient pulses of carbon and nitrogen to stimulate aquatic productivity and respiration. Nutrients are recycled through decomposition of dead plant and animal biomass, which releases simple organic compounds or elements into solution for reacquisition by autotrophs.

Some nutrients are lost during trophic transfers. Carbon is lost (exported) from ecosystems as  $\text{CO}_2$  during respiration. Gaseous or dissolved  $\text{CO}_2$  remains available to organisms in the atmosphere and oceanic pools. Organic biomass can be blown or washed away. Soluble nutrients are exported as water percolates through the ecosystem and enters streams. The efficiency with which nutrients are retained within an ecosystem reflects their relative availability. Nutrients such as nitrogen and phosphorus often are limiting, and tend to be cycled and retained in biomass more efficiently than are nutrients that are more consistently available, such as potassium and calcium. The following four examples exemplify the processes involved in biogeochemical cycling.



**FIG. 11.6** The hydrologic cycle. Net evaporation over the oceans is the source of water vapor carried inland by air currents. Water precipitated into terrestrial ecosystems eventually is returned to the ocean.

### 1. Hydrologic Cycle

Water availability, as discussed in Chapters 2 and 9, is one of the most important factors affecting the distribution of terrestrial organisms. Many organisms are modified to optimize their water balances in arid ecosystems, e.g., through their adaptations for acquiring and retaining water (Chapter 2). The amount of water available to plants is a primary factor in photosynthesis and ecosystem energetics (see above). Water absorbs solar energy, with little change in temperature, thereby buffering humid ecosystems against large changes in temperature. At the same time, water use by organisms significantly affects its passage through terrestrial ecosystems.

The primary source of water for terrestrial ecosystems is water vapor from evaporation over the oceans (Fig. 11.6). The availability of water to terrestrial ecosystems is controlled by a variety of factors, including the rate of evaporation, the direction of prevailing winds, atmospheric and topographic factors that affect convection and precipitation, temperature, relative humidity, and soil texture. Water enters terrestrial ecosystems as precipitation and condensation, and as subsurface flow and groundwater derived from precipitation or condensation at higher elevations. Condensation may be a major avenue for the input of water to arid ecosystems. Many plants in arid regions are adapted to acquire water through condensation. Some desert insects also acquire water through condensation on specialized hairs or body parts (R. Chapman 1982). Vegetation intercepts up to 50% of precipitation, depending on crown structure and plant surface area (G. Parker 1983). Most intercepted water evaporates. The remainder penetrates the vegetation as throughfall (water dripping from foliage) and stemflow (water funneled to stems).

Vegetation takes up water primarily from the soil, using some in the synthesis of carbohydrates. Vascular plants conduct water upward and transpire much of it through the

stomata. Evapotranspiration is the major mechanism for maintaining the upward capillary flow of water from the soil to the canopy and is controlled primarily by atmospheric vapor pressure deficit and solar radiation (J. Wallace and McJannet 2010). This active evaporative process greatly increases the amount of water that moves back into the atmosphere, rather than flowing downslope, and can significantly increase levels of atmospheric moisture and condensation for precipitation at a particular site, as discussed below.

Vegetation stores large amounts of water intra- and extracellularly and controls the flux of water through the soil and into the atmosphere. Accumulation of organic material increases the capacity of the soil to store water and further reduces downslope flow. Soil water storage mediates the acquisition of other nutrients by plants in dissolved form. Food passage through arthropods and earthworms, together with materials secreted by soil microflora, bind soil particles together, forming soil aggregates (Hendrix et al. 1990, Setälä et al. 1996). These aggregates increase the water and nutrient storage capacity of the soil and reduce erodibility. Burrowing organisms increase the porosity and water storage capacity of soil and decomposing wood, e.g., earthworms and wood borers (e.g., Eldridge 1994). Macropore flow increases the rate and depth of water infiltration.

Some organisms also control the movement of water in streams. Swamp and marsh vegetation restricts water flow in low gradient ecosystems. Trees falling into stream channels impede water flow. Similarly, beaver dams impede water flow and store water in ponds. However, water eventually evaporates or reaches the ocean, completing the cycle.

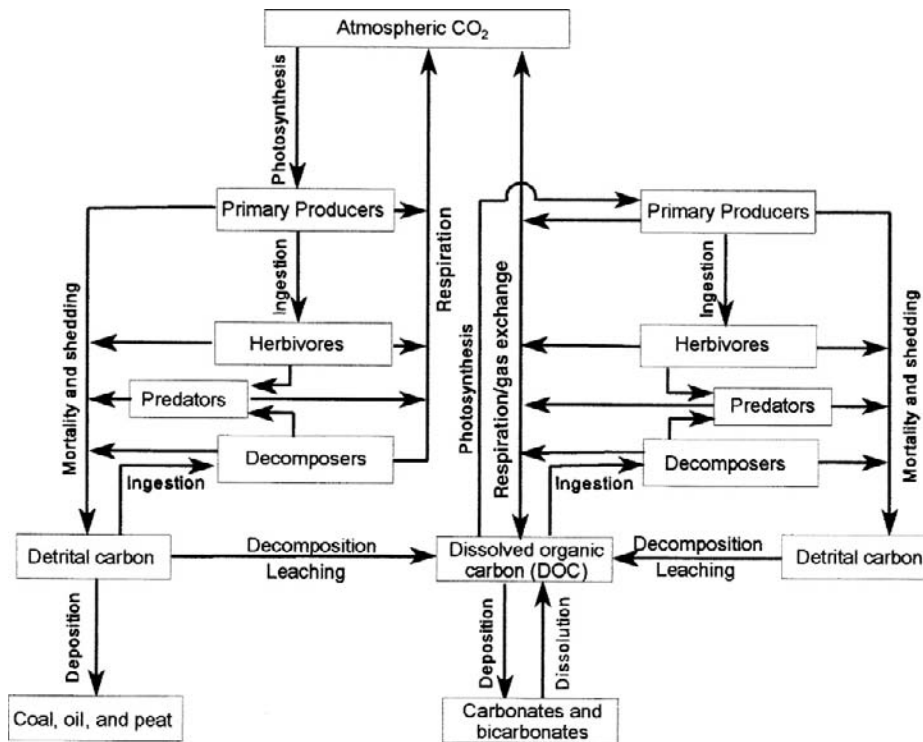
## 2. Carbon Cycle

The carbon cycle (Fig. 11.7) is particularly important because of its intimate association with energy flow, via the transfer of chemical energy in carbohydrates, through ecosystems. Carbon is stored globally as atmospheric carbon dioxide and as sedimentary and dissolved carbonates (principally calcium carbonate). The atmosphere and ocean mediate the global cycling of carbon among terrestrial and aquatic ecosystems. The exchange of carbon between the atmosphere and dissolved or precipitated carbonates is controlled by temperature, carbonate concentration, salinity, and biological uptake that affects concentration gradients (Keeling et al. 1995, Sarmiento and Le Quéré 1996).

Carbon enters ecosystems primarily as a result of photosynthetic fixation of  $\text{CO}_2$  in carbohydrates. The chemical energy stored in carbohydrates is used to synthesize all the organic molecules used by plants and animals. Carbon enters many aquatic ecosystems, especially those with limited photosynthesis, primarily as allochthonous inputs of exported terrestrial materials (e.g., terrestrial organisms captured by aquatic animals, detritus, and dissolved organic material entering with runoff or leachate). Carbon is transferred among trophic levels through consumption, converted into an astounding diversity of compounds for a variety of uses, and eventually is returned to the atmosphere as  $\text{CO}_2$  from respiration, especially during decomposition of dead organic material, thereby completing the cycle. However, loss of carbon from an ecosystem is minimized by rapid acquisition and immobilization of soluble and fine particulate carbon by soil organisms and aquatic filter feeders, from which carbon becomes available for transfer within soil and aquatic food webs (de Ruiter et al., 1995, J.B. Wallace and Hutchens 2000).

However, some carbon compounds (especially complex polyphenols, e.g., lignin) decompose very slowly, if at all, and are stored for long periods as soil organic matter, peat, coal, or oil. Humic compounds are phenolic polymers that are resistant to chemical



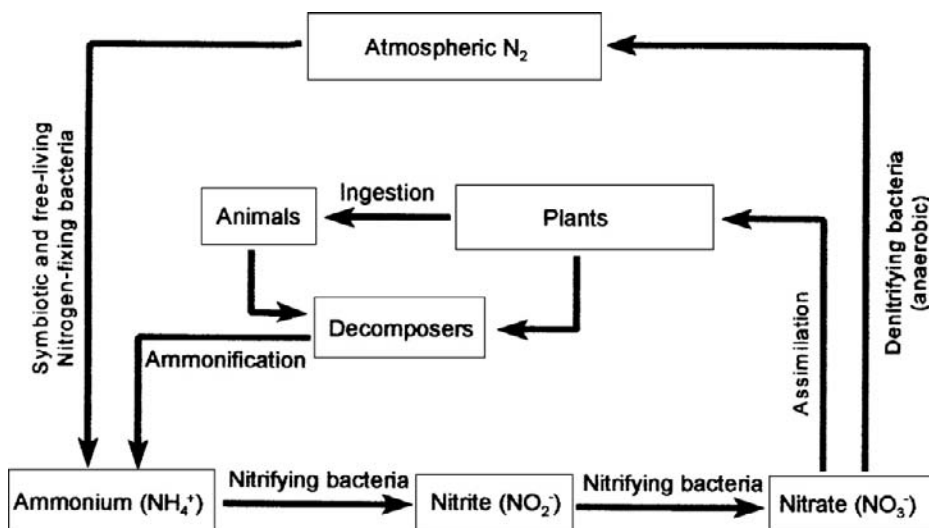


**FIG. 11.7** The global carbon cycle. The atmosphere is the primary source of carbon for terrestrial ecosystems (left), whereas dissolved carbonates and bicarbonates are the primary source of carbon for marine ecosystems (right). Exchange of carbon between atmosphere, hydrosphere and geosphere is regulated largely by biotic uptake and deposition.

decomposition and constitute long-term carbon storage in terrestrial soils. These compounds contribute to the capacity of the soil to hold water and nutrients, because of their large surface area and numerous binding sites. Plants produce organic acids that are secreted into the soil through their roots. These acids facilitate the extraction of mineral nutrients from soil exchange sites, maintain ionic balance (with mineral cations), reduce soil pH, and often inhibit the decomposition of organic matter. Similarly, peat accumulates in bogs, where the low pH inhibits decomposition, and may eventually be buried, contributing to formation of coal or oil. Coal and oil represent long term storage of accumulated organic matter that decomposed incompletely as a result of burial, anaerobic conditions, and high pressure. The carbon removed from the atmosphere by these fossil plants is now reentering the atmosphere rapidly, as a result of fossil fuel combustion, leading to increased atmospheric concentrations of CO<sub>2</sub>.

### 3. Nitrogen Cycle

Nitrogen is a critical element for the synthesis of proteins and nucleic acids, but is available in only limited amounts in most ecosystems. The atmosphere is the reservoir of elemental nitrogen, making nitrogen an example of a nutrient with an atmospheric cycle (Fig. 11.8). Most organisms cannot use gaseous nitrogen or many other nitrogen compounds. In fact, some common nitrogen compounds are toxic in small amounts to most organisms (e.g., ammonia). Nitrogen cycling is mediated by several groups of



**FIG. 11.8** The nitrogen cycle. Bacteria are the primary organisms responsible for transforming elemental nitrogen into forms available for assimilation by plants. Note that the return of nitrogen to the atmospheric pool occurs almost exclusively under anaerobic conditions.

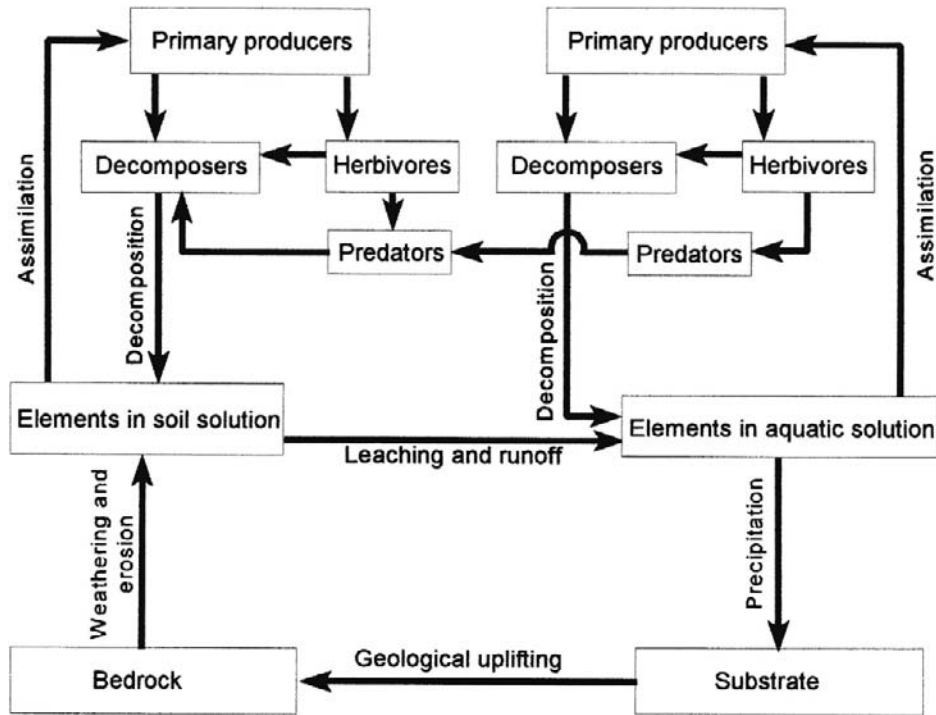
microorganisms that transform toxic or unavailable forms of nitrogen into biologically useful compounds.

Gaseous  $N_2$  from the atmosphere becomes available to organisms through fixation in ammonia, primarily by nitrogen-fixing bacteria and cyanobacteria. These organisms are key components of most ecosystems, but are particularly important in ecosystems that are subject to periodic massive losses of nitrogen, such as through fire. Ammonium compounds also are produced by lightning and volcanic eruptions. Many early successional plants, especially in fire-dominated ecosystems, have symbiotic association with nitrogen-fixing bacteria present in root nodules. These plants can use the ammonia produced by the associated bacteria, but most plants require nitrate ( $NO_3^-$ ) as their source of nitrogen.

Nitrifying bacteria oxidize ammonia to nitrite ( $NO_2^-$ ) and nitrate, which then is available to plants for the synthesis of amino acids and nucleic acids, and transferred to higher trophic levels through consumption. The nitrogen compounds in dead organic matter are decomposed to ammonium by ammonifying bacteria. T.E. Wood et al. (2009) demonstrated that experimental addition of leaf litter to tropical forest floor increased leaf litter production and litter nitrogen content by 92% and 156%, respectively, within 4–5 mos.

Organic nitrogen enters aquatic ecosystems as exported terrestrial organisms, detritus, or runoff and leachate solutions. Nitrogen in freshwater ecosystems is transferred among trophic levels through consumption, eventually reaching marine ecosystems.

Under anaerobic conditions, which occur naturally and as a result of anthropogenic eutrophication or soil compaction, anaerobic denitrifying bacteria convert nitrate to gaseous nitrogen, which is lost to the atmosphere, thereby completing the cycle. However, nitrogen loss is minimized by soil organisms that aerate the soil through excavation and by the rapid acquisition and immobilization of soluble nitrogen by soil microorganisms



**FIG. 11.9** Sedimentary cycle. Phosphorus and other non-gaseous nutrients precipitate from solution and are stored largely in sediments of marine origin. These nutrients become available to terrestrial ecosystems primarily through chemical weathering of uplifted sediments.

and aquatic filter feeders, from which nitrogen becomes available to plants and to soil and aquatic food webs.

#### 4. Sedimentary Cycles

Many nutrients, including phosphorus and mineral cations, are available only from sedimentary sources. These nutrients are cycled in similar ways, as exemplified by phosphorus (Fig. 11.9). Phosphorus is biologically important in molecules that mediate energy exchange during metabolic processes (ATP and ADP) and in phospholipids. Like nitrogen, it is available to organisms only in certain forms and is in limiting supply in most ecosystems. Phosphorus and mineral cations become available to terrestrial ecosystems as a result of chemical weathering or erosion of geologically uplifted, phosphate-bearing sediments.

Phosphate enters an ecosystem from weathered bedrock and moves among terrestrial ecosystems through materials washed downslope or filtered from the air. Phosphorus is highly reactive, but available to plants only as phosphate, which often is bound to soil particles. Plants extract phosphorus (and mineral cations) from cation exchange and sorption sites on soil particles and from soil solution. Phosphorus then is synthesized into biological molecules and transferred to higher trophic levels through consumption; it eventually is returned to the soil as dead organic matter and is decomposed. Phosphorus enters aquatic ecosystems largely in particulate forms that have been exported from terrestrial ecosystems. It is transferred between aquatic trophic levels through consumption, eventually being deposited in deep ocean sediments, completing the cycle. Phosphorus loss is minimized

by soil organisms and aquatic filter feeders that rapidly acquire and immobilize soluble phosphorus and make it available for plant uptake and exchange among soil and aquatic organisms.

### C. Factors Influencing Cycling Processes

A number of factors alter the rates and pathways of biogeochemical fluxes. Variation in fluxes reflects the chemical properties and source of the nutrient, interactions with other cycles, and the composition of the community, especially the presence of specialized organisms that control particular fluxes. Hence, changes in community composition which result from disturbance and recovery alter the rates and pathways of these fluxes.

The chemical properties of various elements and compounds, especially their solubility and susceptibility to pH changes, as well as their biological uses, affect cycling behavior. Some elements, such as Na and K, form compounds that are readily soluble over normal ranges of pH. These elements generally have high rates of input to ecosystems via precipitation, but also high rates of export via runoff and leaching. Other elements, such as Ca and Mg, form compounds that are not as soluble over usual ranges of pH and have lower rates of input and export. Elements such as nitrogen and phosphorus are necessary for all organisms, relatively limiting, and generally conserved within organisms. For example, deciduous trees typically resorb nitrogen from senescing foliage prior to leaf fall (Gutschick 1999, Marschner 1995). Sodium has no known function in plants, and is not retained in plant tissues, but is required by animals for osmotic balance and for muscle and nerve function. Consequently, it is conserved tightly by these organisms. In fact, animals often seek mineral sources of sodium (e.g., Seastedt and Crossley 1981b). Many decay fungi accumulate sodium (Cromack et al. 1975, Schowalter et al. 1998), despite the absence of any apparent use in fungal metabolism, perhaps to attract animal vectors of fungal spores.

Biogeochemical cycles interact with each other in complex ways (Daufresne and Loreau 2001, Elser and Urabe 1999, Rastetter et al. 1997, Sterner and Elser 2002). For example, precipitation affects decomposition and carbon storage in soils (Schuur et al. 2001). Some plants respond to increased atmospheric CO<sub>2</sub> by reducing stomatal opening, thereby acquiring sufficient CO<sub>2</sub> while reducing water loss. Hence, the increased size of the atmospheric pool of CO<sub>2</sub> may alter transpiration, permitting some plant species to colonize more arid habitats. Nitrogen subsidies, either from anthropogenic atmospheric deposition or as pulses of biogenic inputs (e.g., Carlton and Goldman 1984) can stimulate photosynthesis and primary production, but depress decomposition and mineralization (Throop et al. 2004, Treseder 2008, G. Waring and Cobb 1992), with varying effects on herbivory (Kytö et al. 1996, G. Waring and Cobb 1992, see Chapter 3). Similarly, the calcium cycle interacts with the cycles of several other elements. Calcium carbonate generally accumulates in arid soils as soil water evaporates. Acidic precipitation, such as that resulting from industrial emission of nitrous oxides and sulfur dioxide into the atmosphere, dissolves and leaches calcium carbonate from soils and sediments. Soils with high content of calcium carbonate are relatively buffered against pH change, whereas those depleted of calcium carbonate become acidic, increasing the export (through leaching) of other cations as well.

Some biogeochemical fluxes are controlled by particular organisms. The nitrogen cycle depends on several groups of microorganisms that control the transformation of nitrogen among various forms that available or unavailable to other organisms (see above).

Soil biota secrete substances that bind soil particles into aggregates that facilitate retention of soil water and nutrients. Some plants (e.g., the western redcedar, *Thuja plicata*, and dogwoods, *Cornus* spp.) accumulate calcium in their tissues (Kiilsgaard et al. 1987) and generally increase the pH and buffering capacity of surrounding soils. Their presence or absence thereby affects the retention of other nutrients, as well. Oaks, *Quercus* spp., and spruces, *Picea* spp., emit large amounts of carbon as volatile isoprene that affects the oxidation potential of the atmosphere (Lerdau et al. 1997).

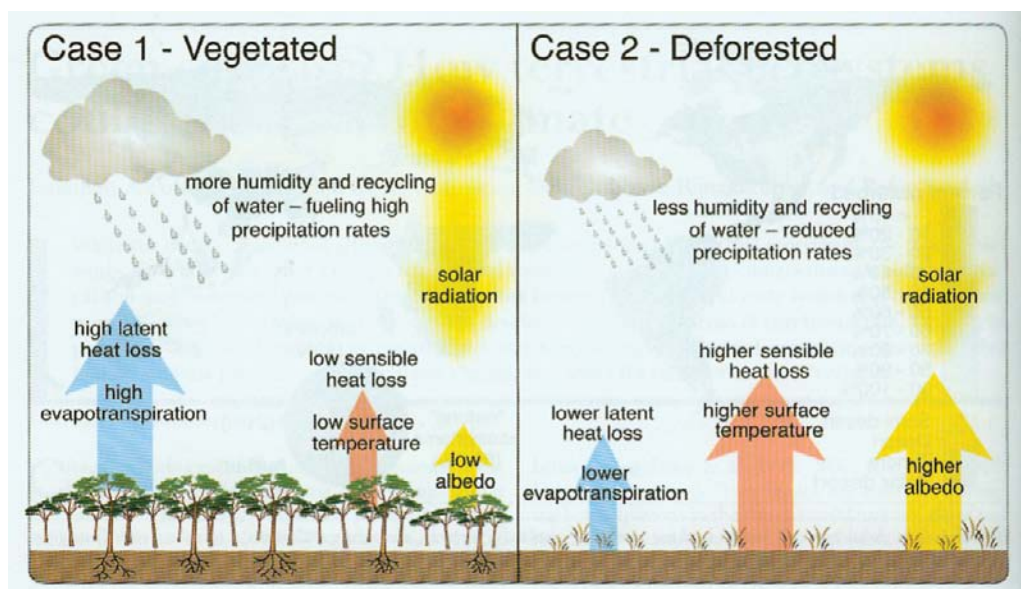
The changes in community composition which follow a disturbance or occur during succession affect the rates and pathways of biogeochemical fluxes. Early successional communities are frequently inefficient, because of limited competition for resources by the small biomass, and early successional species have little selective pressure to retain nutrients. For example, the early successional tropical tree, *Cecropia* spp., has large, thin leaves that transpire water more rapidly than do the smaller, more sclerotized leaves of later successional species. Although later successional communities are not always efficient, declining resource supply relative to growing biomass promotes the efficient retention of nutrients within the ecosystem (E. Odum 1969, Schowalter 1981).

Agricultural and silvicultural systems are relatively inefficient, largely because communities which are composed of a single, or few, plant species cannot acquire or retain all available forms of matter effectively. Furthermore, the diversity of organisms in natural systems may increase per capita resource acquisition or provide overall resistance to herbivores and pathogens (Cardinale et al. 2002, A. Hunter and Arssen 1988). Nitrogen fixation often is controlled by non-commercial species, such as symbiotic nitrogen-fixing lichens, herbs and shrubs, or structures, such as large decomposing woody litter, that are suppressed or eliminated by management activities. Necessary nitrogen then must be supplied anthropogenically, often in excess amounts that leach into groundwater and streams, resulting in eutrophication and hypoxia of aquatic ecosystems. Exotic species also can alter nutrient cycling processes. Liu and Zou (2002) reported that invasion of tropical pastures and wet forest in Puerto Rico by exotic earthworms significantly increased decomposition rates.

#### IV. CLIMATE MODIFICATION

Although most previous ecology texts have emphasized the effect of climate on survival, population growth, and distribution of organisms (see Chapters 2, 6 and 7), some communities are capable of significant modification of local and regional climatic conditions, perhaps influencing global climatic gradients (T. Chase et al. 1996, J. Foley et al. 2003a, Juang et al. 2007, G. Parker 1995, Pielke and Vidale 1995). Climate modification largely reflects the capacity of vegetation to shade and protect the soil surface, abate airflow, and control water fluxes (Fig. 11.10). Isoprene emission by some plant species apparently increases the tolerance of leaves to high temperatures and also affects the oxidation potential of the atmosphere (Lerdau et al. 1997). Biomes and successional stages vary widely in their ability to modify climate.

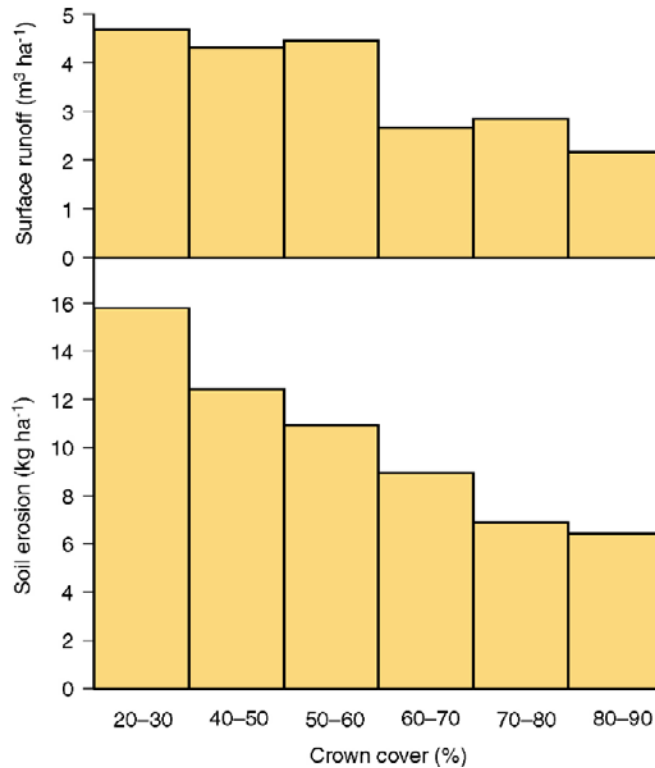
When vegetation development or moisture is limited, as in deserts, the soil surface is exposed fully to sunlight and contains insufficient water to restrict temperature change (T. Lewis 1998). The reflectivity of the soil surface (albedo) determines the absorption of solar energy and heat. Soils with high organic content have lower albedo (0.10) than does desert sand (0.30) (Monteith 1973). Albedo also declines with increasing soil



**FIG. 11.10** Diagrammatic representation of the effects of vegetation on climate and atmospheric variables. The capacity of vegetation to modify climate depends on vegetation density and vertical height and complexity. From J. Foley et al. (2003a) with permission of the Ecological Society of America.

water content. In the absence of vegetation cover, surface temperatures can reach 60–70 °C during the day (e.g., Seastedt and Crossley 1981a) but fall rapidly at night as a result of long-wavelength (infrared) radiation from the surface. Exposure to high wind speeds dries soil and moves soil particles into the atmosphere. Soil desiccation reduces the infiltration of precipitation, leading to greater runoff and erosion. These altered soil characteristics increase albedo, surface heating and advective flux of moist air, leading to increased surface warming and drying (J. Foley et al. 2003a).

Vegetation modifies local climatic conditions in several ways. Even the thin (3 mm) biological crusts, composed of cyanobacteria, green algae, lichens and mosses, on the surface of soils in arid and semi-arid regions are capable of modifying surface conditions and reducing erosion (Belnap and Gillette 1998). During the day, vegetation shades the surface of the ground, reducing its temperature (T. Lewis 1998). Vegetation also absorbs solar radiation to drive photosynthesis and evapotranspiration (G. Parker 1995), further cooling the near-surface boundary zone (see below). At night, vegetation absorbs re-radiated infrared energy from the ground, maintaining warmer nocturnal temperatures, compared to non-vegetated areas. As a result, vegetation reduces variation in diurnal and annual temperature ranges. Vegetation also intercepts precipitation and reduces the impact of rain drops on the soil surface, although this effect depends on rainfall volume and droplet size (Calder 2001). Vegetation also impedes the downslope movement of water, thereby reducing erosion and loss of soil. Soil organic matter retains water, increasing the capacity of the soil to hold moisture, reducing temperature change. Resistance to airflow by vegetation reduces wind speeds and increases turbulence, contributing to deposition of airborne particles and aerosols and generating convection, which in turn increases local

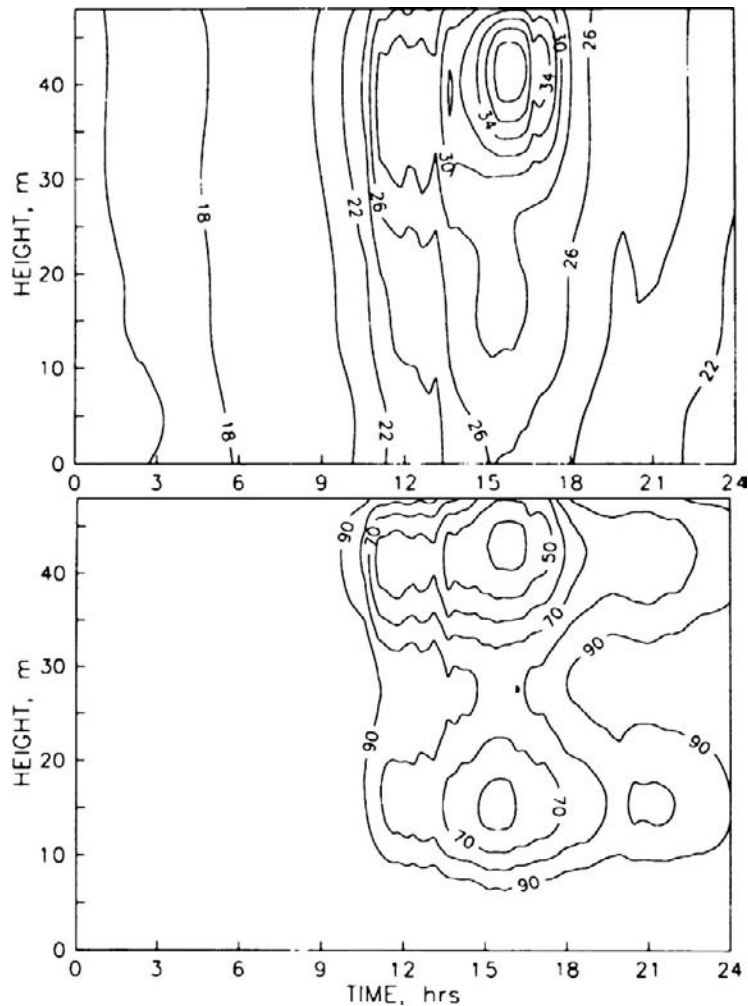


**FIG. 11.11** Effect of canopy cover on average runoff and soil erosion, based on 41 runoff-producing storms totaling 1128 mm in northern Thailand. Data from Ruangpanit (1985).

precipitation. Exposure of individual organisms to damaging or lethal wind speeds is reduced as a result of buffering by surrounding individuals.

The degree of climate modification depends on vegetation height, density and “roughness” (the degree of unevenness of canopy topography). Albedo is inversely related to vegetation height and roughness, declining from 0.25 for vegetation < 1.0 m in height to 0.10 for vegetation > 30 m height, and generally reaches its lowest values for vegetation with an uneven canopy surface, e.g., tropical forest, and highest values in vegetation with a smooth canopy surface, e.g., agricultural crops (Monteith 1973). Canopy surface roughness creates turbulence in air flow, contributing to surface cooling by wind (sensible heat loss) and evapotranspiration (latent heat loss) (J. Foley et al. 2003a, Juang et al. 2007).

Sparse vegetation has a lower capacity to modify temperature, water flux and wind speed than does dense vegetation. Shorter vegetation traps less radiation between multiple layers of leaves and stems and modifies climatic conditions within a shorter column of air, compared to taller vegetation. Tall, multi-canopied forests have the greatest capacity to modify local and regional climate, because the stratified layers of foliage and dense understory successively trap filtered sunlight, intercept precipitation and through-fall, contribute to evapotranspiration, and impede airflow in the deepest column of air. G. Parker (1995) demonstrated that rising temperatures during midday had the greatest effect in upper canopy levels in a temperate forest (Fig. 11.12). Temperature at heights



**FIG. 11.12** Height-time profiles of air temperature and relative humidity in mixed-hardwood forest in Maryland. Temperature contours are 2°C; relative humidity contours are 10% intervals. Nocturnal temperature gradients are weak, but a hot spot develops in the upper canopy in mid-afternoon. Humidity declined in the upper canopy in mid-afternoon, coincident with peak temperatures, and was near saturation (> 95%) outside the marked contours. From G. Parker (1995).

between 40 and 50 m ranged from 16°C at night to 38°C during mid-afternoon (a diurnal fluctuation of 22°C); relative humidity in this canopy zone declined from > 95% at night to 50% during mid-afternoon (G. Parker 1995). Below 10 m, the temperature fluctuation was only 10°C, and relative humidity was constant at > 95%. Windsor (1990) and Madigovsky (2004) reported similar gradients in the canopy environment of lowland tropical forests.

Vegetation can control local and regional precipitation patterns to a significant extent through evapotranspiration. Surface cooling by vegetation lowers the altitude at which moisture condenses, while vegetation-generated evapotranspiration, turbulence and latent heat flux combine to elevate moist air to the height of condensation, increasing local precipitation (Janssen et al. 2008, Juang et al. 2007, Trenberth 1999). Higher rates of local



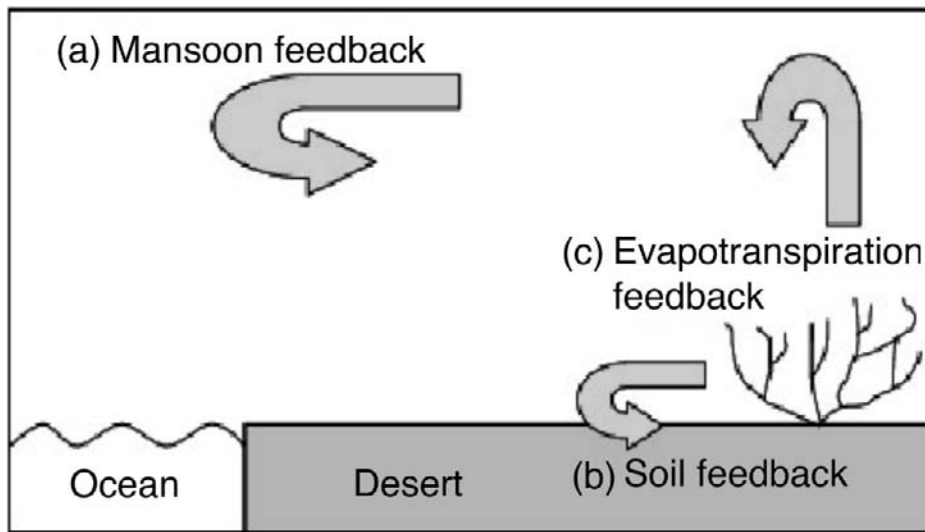


**FIG. 11.13** Deforestation in Panama. Removal of tropical rain forest cover has exposed soil to solar heating and severe erosion, leading to continued ecosystem deterioration and, potentially, to altered regional temperature and precipitation patterns.

recycling (>20%) occur where rates of evapotranspiration and convective flux are high and advective moisture flux is low (Trenberth 1999). As much as 30% of precipitation in tropical rainforests in the Amazon basin is generated locally by evapotranspiration (Salati 1987, Trenberth 1999).

Insects and other organisms (including humans) alter vegetation and soil structure (Fig. 11.13) and thereby affect biotic control of local and regional climate (see Chapters 12–14). Deforestation or desertification reduce evapotranspirative cooling, exacerbating the effect of increased albedo, thereby increasing surface temperatures and reducing precipitation and relative humidity (J. Foley et al. 2003a, b, Janssen et al. 2008, Juang et al. 2007, T. Lewis 1998, Salati 1987, Trenberth 1999). Costa and Foley (2000) calculated a net warming of 1–2°C in tropical regions as a result of deforestation, an effect that would exacerbate the warming due to increased atmospheric CO<sub>2</sub>. Forest fragmentation increases wind fetch and the penetration of air from surrounding crop or pasture zones into the fragmented remnants (J. Chen et al. 1995). Belnap and Gillette (1998) found that trampling of the brittle biological crusts on desert soils by livestock greatly increased the effect of wind on soil loss. Increased deposition of airborne particulates reduces exposure to photosynthetically active radiation.

Deforestation and desertification initiate positive feedback between climate and vegetation change. Holocene warming led to northward advance of the boreal forest, which lowered albedo and contributed to continued warming of the ecotone (J. Foley et al. 1994). Schlesinger et al. (1990) reported that desertification in southwestern North America resulted in a destabilizing positive feedback, whereby initial vegetation removal caused surface warming and drying that stressed and killed adjacent vegetation, leading



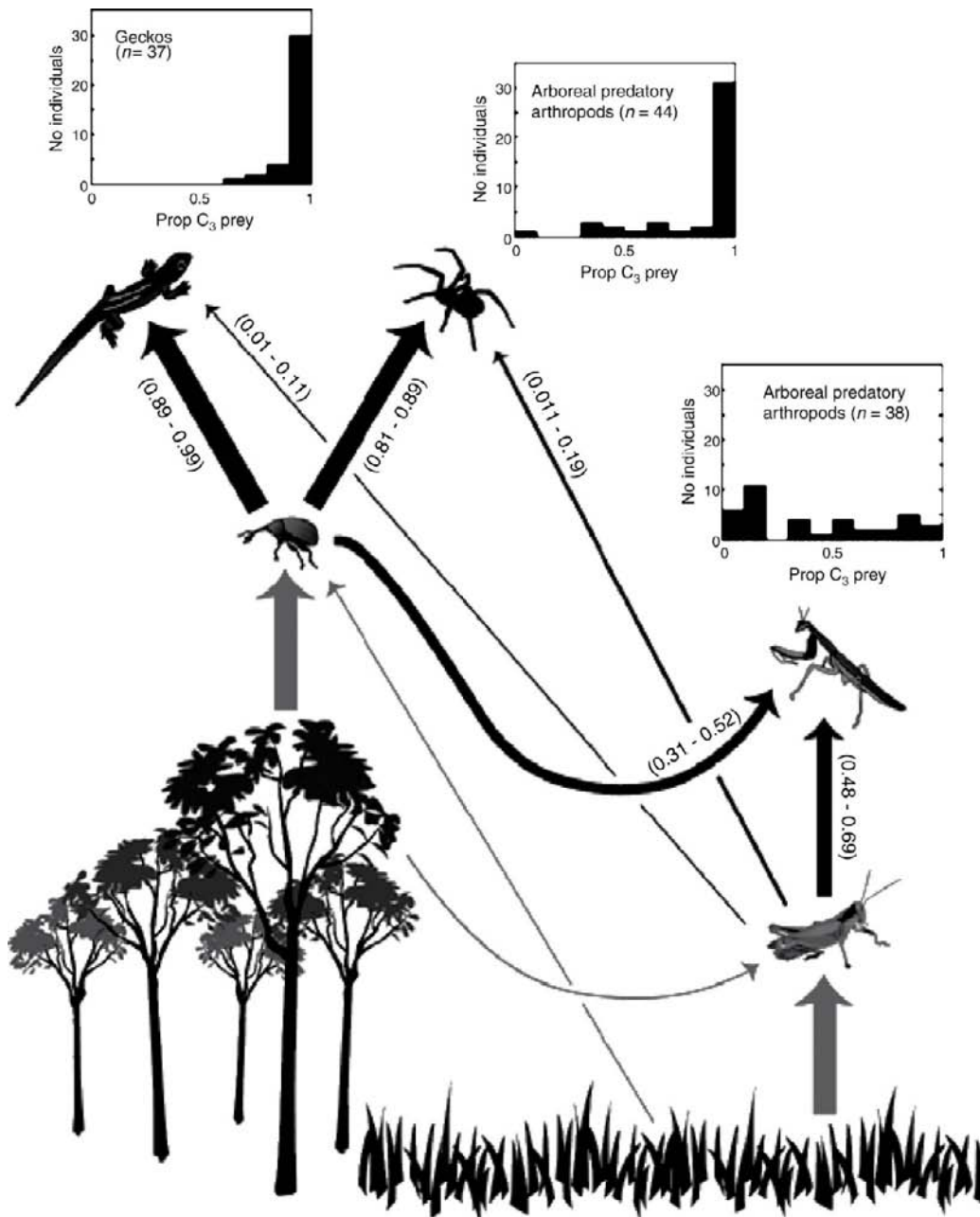
**FIG. 11.14** Three feedbacks by which semiarid vegetation contributes to positive feedback on growth conditions in sub-Saharan Africa. a) The monsoon feedback results from reduced surface albedo that modifies monsoon circulation, b) the soil feedback reflects increased soil water availability associated with vegetation, and c) the evapotranspiration feedback results from increased evapotranspiration in vegetated areas, which increases atmospheric humidity and precipitation of the area. From Janssen et al. (2008) with permission from the authors and John Wiley & Sons.

to an advancing arc of desertified land. Similar processes contribute to the desertification of Sub-Saharan Africa (Fig. 11.14, J. Foley et al. 2003b, Janssen et al. 2008). The effects of similar, large-scale vegetation changes resulting from insect outbreaks on regional climatic conditions have not been evaluated, although Classen et al. (2005) reported that increased soil temperature and moisture caused by manipulated levels of herbivory were of sufficient magnitude to drive changes in ecosystem processes. K. Clark et al. (2010) and Kurz et al. (2008) reported that outbreaks significantly reduced net ecosystem productivity and transformed forests from carbon sinks to carbon sources, potentially contributing to further climate change.

## V. ECOSYSTEM MODELING

Modeling has become a useful tool for testing hypotheses concerning the behavior and self regulation of complex systems (e.g., Camilo and Willig 1995, B. Patten 1995, Ulanowicz 1995) and for predicting ecosystem responses to environmental changes, as well as ecosystem contributions to environmental change, especially carbon flux (e.g., Rastetter et al. 1991, Sarmiento and Le Quéré 1996). The logistical difficulty of measuring and manipulating all ecosystem components and processes for experimental purposes has placed greater emphasis on modeling to simulate experimental conditions and to identify critical components and processes for further study.

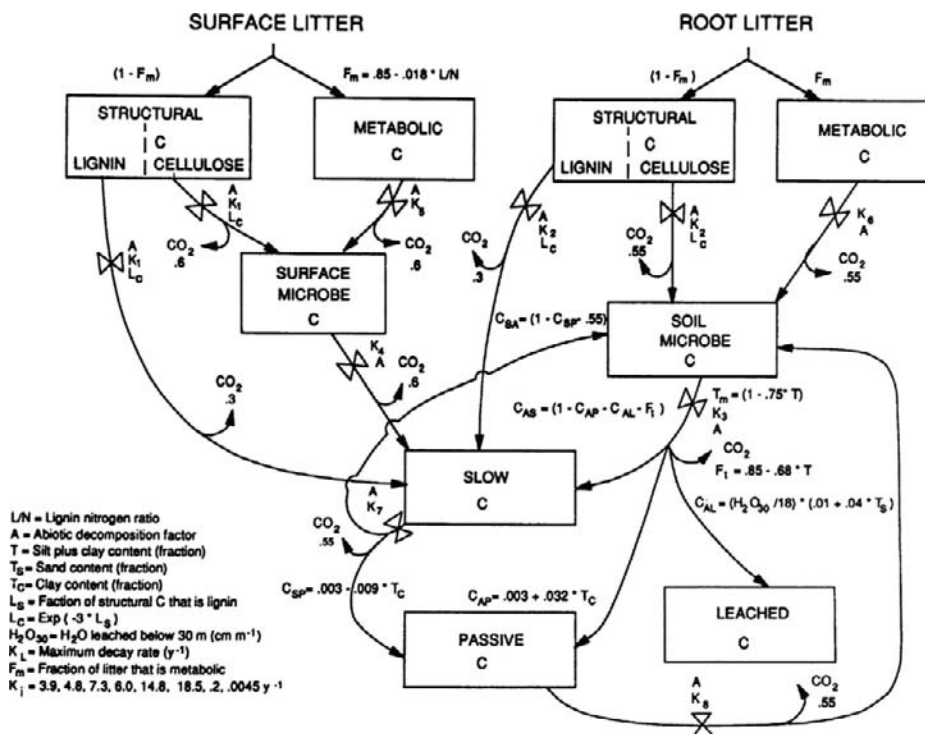
Modeling at the ecosystem level necessarily starts with conceptual models of linkages among components and reflects the individual modeler's perception of the importance



**FIG. 11.15** Diagram of interaction strengths linking canopy and understory food webs in a savanna ecosystem in central Kenya. Values in parentheses represent the range of three mean dietary proportions of  $C_3$ -feeding prey for each link based on  $\delta^{13}C$  trophic discrimination factors (on  $\Delta^{13}C$ ). Links between predators and prey (black lines) are proportional in width to the mean proportion of diet constituted by that link. Histograms illustrate the proportion of  $C_3$ -feeding prey in the diets of individual predators. The width of the links between prey and plants (grey lines) reflect estimated, not calculated, diet proportions. From R. Pringle and Fox-Dobbs (2008) with permission from John Wiley & Sons.

of particular components and interactions (e.g., Figs. 1.3, 11.6–11.9). Models differ in the degree to which species are distinguished in individual submodels or combined into functional group submodels (de Ruiter et al. 1995, Naeem 1998, Polis 1991b, Reagan et al. 1996) and to which light, water, and nutrient availability are integrated simultaneously with changes in ecosystem structure and composition (e.g., R. Waring and Running 1998). Obviously, conceptualizing the integration of the many thousands of species and other components in a given ecosystem is virtually impossible. On the other hand, some global-scale models distinguish the biota only at the community level, if at all. The degree to which individual species are distinguished influences the representation of the variety of interactions and feedbacks that, in turn, influence ecosystem parameters (Naeem 1998, Polis 1991b, Reagan et al. 1996). Similarly, models which are based on a limited set of variables in order to predict a single type of output (e.g., carbon flux) may fail to account for the effects of other variables (e.g., effects of limiting nutrients, such as nitrogen, on carbon flux) (R. Waring and Running 1998). More general models require simplifying assumptions to expand their application and may lose accuracy as a consequence.

After the conceptual organization of the model has been determined, interaction strengths are quantified (Figs. 11.15, 11.16), based on available data, or subjected to sensitivity analysis to identify the range of values that represent observed interaction (e.g., Benke and Wallace



**FIG. 11.16** Detail of carbon fluxes in the soil organic carbon submodel of the CENTURY ecosystem model. This model can be coupled to the nitrogen submodel. From Parton et al. (1993) courtesy of the American Geophysical Union.

1997, Dambacher et al. 2002, de Ruiter et al. 1995, Parton et al. 1993 R. Pringle and Fox-Dobbs 2008, Rastetter et al. 1991, 1997, Running and Gower 1991). Direct and indirect interactions can be represented in transition matrix form, e.g.,

$$\begin{array}{cccccccc}
 & \mathbf{N}_1 & \mathbf{N}_2 & \mathbf{N}_3 & \mathbf{N}_4 & \cdot & \cdot & \mathbf{N}_j \\
 \mathbf{N}_1 & \alpha_{11} & \alpha_{21} & \alpha_{31} & \alpha_{41} & \cdot & \cdot & \alpha_{i1} \\
 \mathbf{N}_2 & \alpha_{12} & \alpha_{22} & \alpha_{32} & \alpha_{42} & \cdot & \cdot & \alpha_{i2} \\
 \mathbf{N}_3 & \alpha_{13} & \alpha_{23} & \alpha_{33} & \alpha_{43} & \cdot & \cdot & \alpha_{i3} \\
 \mathbf{N}_4 & \alpha_{14} & \alpha_{24} & \alpha_{34} & \alpha_{44} & \cdot & \cdot & \alpha_{i4} \\
 \cdot & \cdot & \cdot & \cdot & \cdot & \cdot & \cdot & \cdot \\
 \cdot & \cdot & \cdot & \cdot & \cdot & \cdot & \cdot & \cdot \\
 \mathbf{N}_j & \alpha_{1j} & \alpha_{2j} & \alpha_{3j} & \alpha_{4j} & \cdot & \cdot & \alpha_{ij}
 \end{array}$$

where  $\mathbf{N}_j$  is the  $j$ th ecosystem component, and  $\alpha_{ij}$  is the relative effect (direct + indirect) of  $\mathbf{N}_j$  on  $\mathbf{N}_i$ . When  $\mathbf{N}_i = \mathbf{N}_j$ ,  $\alpha_{ij}$  represents intrinsic (intraspecific) effects on numbers or mass. Differential equations of the general form:

$$\mathbf{N}_{i(t+1)} = \mathbf{N}_{it} + \sum (\alpha_{ij} \mathbf{N}_{jt}) \quad (11.1)$$

are used to calculate the transitional states of each component as input conditions change. Note the application of this inclusive equation to equations for growth of individual populations and interacting species in [Chapters 6 and 8](#). Components must be linked so that changes in the number, mass, or energy or nutrient content of one component have appropriate effects on the numbers, masses, or energy or nutrient contents of other components. Models focused on species emphasize the fluxes of energy or matter through food webs. By contrast, models focused on energy or matter pools emphasize fluxes of energy and matter among pools, but may include important species that affect flux rates.

Ecosystem models are sensitive to effects of indirect interactions. The availability of nutrients and directions of fluxes indirectly affect all organisms. For example, a direct predator–prey interaction reduces prey abundance and directs energy and nutrients through that predator, thereby indirectly affecting the resources available for other organisms, as well as the interactions between that prey and its competitors, hosts, and other predators (see [Chapter 8](#)). Ultimately, the indirect effects of this interaction can affect primary production, canopy cover and resource availability in ways that determine climate, substrate and resource conditions for the entire ecosystem. Non-trophic interactions are difficult to recognize and measure (Dambacher et al. 1999, 2002, O’Neill 2001); quantitative data are available for relatively few potential indirect interactions. Accordingly, the complexity of indirect, as well as direct, interactions is difficult to model, but has important implications for how ecosystems respond to environmental changes (see [Chapter 15](#)).

A number of models have been developed to predict the fluxes of energy or key elements, especially carbon or nitrogen, through ecosystems. However, as noted above, interactions among various cycles (e.g., nitrogen and carbon cycles integrated through biomolecules, carbon and calcium cycles integrated in carbonates, or nitrogen and calcium

cycles integrated through soil pH change) may confound predictions which are based on individual resources.

Comprehensive ecosystem models that integrate energy, carbon, water and nutrient fluxes include FOREST-BGC/BIOME-BGC (Running and Gower 1991) and CENTURY (e.g., Fig. 11.16, Parton et al. 1993, Throop et al. 2004), which have been modified to represent a variety of ecosystem types. These models are useful for predicting global biogeochemical processes because they integrate common ecosystem processes in a logical framework, have minimum requirements for detail of inputs for ecosystem characteristics, and account for the mass balances of multiple nutrients moving through interacting plants, detritus, decomposers and abiotic pools. This ecological stoichiometry (Daufresne and Loreau 2001, Sterner and Elser 2002) provides a tool for evaluating consequences of changes in mass balances among multiple elements as a result of changes in environmental conditions or community interactions. The effects of insects and other invertebrates have rarely been incorporated in these, or other, existing ecosystem models. Throop et al. (2004) used the CENTURY model to predict the effects of atmospheric nitrogen deposition and herbivory on C and N fluxes and found that herbivory depressed plant and soil C storage and N mineralization. Most often, insects are combined as “insects” or “arthropods”, thereby losing valuable information about this diverse group, species of which can respond dramatically and differentially to environmental change and have major effects on ecosystem properties (Chapters 2, 6, 12–14).

## VI. SUMMARY

An ecosystem represents the integration of the biotic community and the abiotic environment. The capacity of the community to modify its environment depends on its structure and the degree to which it controls energy flow, biogeochemical cycling and climatic conditions.

The structure of an ecosystem reflects the organization of various abiotic and biotic pools that exchange energy and matter. Abiotic pools are the atmosphere, oceans and sediments, which represent the sources of energy and matter for biotic use. Biotic pools are the various organisms (individuals, species populations, functional groups, or trophic levels) in the community. Autotrophs (or primary producers) are those organisms that can acquire resources from abiotic pools. Heterotrophs (or secondary producers) are those organisms that must acquire their resources from other organisms. Energy and matter storage in these pools can be represented as pyramids of productivity, numbers or biomass.

The energy that is available to ecosystems comes primarily from solar radiation, which is captured and stored in carbohydrates by primary producers (autotrophs) through the process of photosynthesis. The total rate of energy capture (gross primary productivity) depends on exposure to sunlight, availability of water, and biomass. Some of the energy from gross primary production is expended through plant respiration. The remaining net primary production is stored as plant biomass and is the source of energy and matter for heterotrophs. Primary heterotrophs (herbivores) feed on autotrophs, whereas secondary heterotrophs (predators) feed on other heterotrophs. Consumption transfers the energy that is stored in consumed biomass to the higher trophic level, with some lost as egestion and consumer respiration. Generally, < 10% of the energy available at each trophic level is converted into biomass at the next higher trophic level, although predators generally have a higher efficiency of conversion than do herbivores. Energy remaining in organisms at the time of death becomes available to decomposers that release the remaining energy through respiration.

Energy is the currency with which organisms acquire and concentrate the material resources necessary for growth and reproduction. Material resources often are available in limited supply, favoring mechanisms that facilitate their retention and reuse within the ecosystem. Biogeochemical cycling represents the processes whereby material resources, including water, carbon, nitrogen and mineral elements, are acquired from abiotic pools and exchanged indefinitely among trophic levels, with eventual return to abiotic pools. The efficiency with which these materials are recycled and conserved, rather than lost to abiotic pools, buffers an ecosystem against resource depletion and reduced productivity. Hence, ecosystems become organized in ways that maximize the capture and storage of resources among organisms. Resources egested or excreted during trophic transfers, as well as via dead organisms, become available to decomposers that rapidly acquire and store the nutrients from organic matter. Nutrients released by decomposers become available for exchange among soil and aquatic organisms and for plant uptake. Microorganisms are particularly instrumental in making nitrogen available for plant uptake, with different specialists fixing atmospheric nitrogen as ammonia, converting ammonia to nitrate, and organic nitrogen to ammonia. Volatilization by fire and denitrification by anaerobic bacteria complete the cycle by returning elemental nitrogen to the atmosphere.

Ecosystems also modify their local and regional climatic conditions. The degree to which vegetation reduces soil warming, evaporation, erosion, and wind speed depends on its density and vertical architecture. Insects and other organisms affect vegetation structure, hence canopy–atmosphere interactions. Tall, multi-canopied forests are the most effective at modifying surface temperatures, relative humidities, and wind speed, thereby ameliorating local and regional fluctuations in temperature, wind speed, and precipitation.

Models have become important tools for synthesizing complex, and often incomplete, data for prediction of ecosystem responses to, and effects on, global environmental changes. Ecosystem models differ in structure and degree of simplification. The effects of insects on a variety of ecosystem parameters have been largely ignored in ecosystem models.

# Herbivory

## I. Types and Patterns of Herbivory

- A. *Herbivore Functional Groups*
- B. *Measurement of Herbivory*
- C. *Spatial and Temporal Patterns of Herbivory*

## II. Effects of Herbivory

- A. *Plant Productivity, Survival and Growth Form*
- B. *Community Dynamics*
- C. *Water and Nutrient Fluxes*
- D. *Effects on Climate and Disturbance Regime*

## III. Summary

### The complexity of herbivore effects on ecosystem structure and function

Although the effects of herbivores on primary production are obvious and well-known, herbivores have complex effects on community structure, biogeochemical processes and climate that may affect long-term ecosystem productivity and other functions. Among the best illustrations of this complexity is a series of studies in northern Arizona, which include long-term manipulation of a stem-boring moth, *Dioryctria albovitella*, and pinyon needle scale, *Matsucoccus acalyptus*, on insect-resistant and susceptible piñon pines, *Pinus edulis*, in a semi-arid woodland (J. Brown et al. 2001).

In two of the earliest studies to demonstrate a range of plant responses to herbivory, Paige and Whitham (1987) and Maschinski and Whitham (1989) found that the effects of grazing depended on the interaction of timing and intensity of grazing, and availability of water or nutrients. Under conditions of adequate water or nutrient supply, naturally-growing plants were capable of substantially overcompensating for herbivory. However, when water or nutrients were insufficient for compensation, herbivory reduced plant production.

Subsequent studies addressed herbivore effects on community dynamics. K. Christensen and Whitham (1991) found that moth feeding on stems and cones reduced cone production and reduced seed dispersal by birds. Birds avoided entire stands of trees with reduced cone production, even though individual insect-resistant trees produced substantial numbers of cones. These data indicated the importance of masting to ensure sufficient cone production to attract seed dispersers. Concurrently, Gehring and Whitham (1991, 1995) showed that folivory significantly reduced mycorrhizal colonization and growth on stressed but not on unstressed trees, thus demonstrating the importance of plant stress to folivore effects on below-ground processes. Whitham et al. (2003, 2006) and Shuster et al. (2006) developed a model of “extended phenotype” that showed how heritable traits that control interactions among organisms and

(cont.)



their effects on community and ecosystem dynamics could lead to evolution at community and ecosystem levels.

Effects on biogeochemical processes were demonstrated by S. Chapman et al. (2003, 2006) and Classen et al. (2007a, b). Herbivory by both moth and scale insect were shown to affect litter quality, mineralization rate and soil microbial abundance and activity. Herbivory increased nitrogen concentration in piñon pine litterfall but reduced microbial biomass. The direction of nutrient release changed with time, i.e., net nitrogen immobilization one year and net mineralization a second year, perhaps reflecting alternating periods of nitrogen mineralization and leaching. These effects were strongly mediated by seasonal rainfall. However, Schweitzer et al. (2005) found that herbivory on *Populus* decelerated decomposition rate, but the effect depended on plant genotype.

The effects of herbivore activity on local climate were demonstrated by Classen et al. (2005). Scale insects reduced the leaf area index of susceptible trees (by 39%) and increased soil temperature (by 26%) and moisture (by 35%), whereas moths had no effect on these variables. However, both insects reduced canopy interception, by 51% (scale insect) and 29% (moth). The magnitude of change in soil temperature and moisture resulting from feeding by scale insects was similar to global change scenarios and sufficient to drive ecosystem processes. The larger size of moth-susceptible trees may buffer them from effects on microclimate, despite changes in crown architecture. This study showed that herbivores are capable of influencing local climate, potentially modifying climate control of ecosystem processes.

## INTRODUCTION

HERBIVORY IS THE RATE OF CONSUMPTION BY ANIMALS OF ANY PLANT parts, including foliage, stems, roots, flowers, fruits or seeds. Direct effects of insects on plant reproductive parts are addressed in Chapter 13. Herbivory is a key ecosystem process that reduces biomass and density of plants or plant materials, transfers mass and nutrients to the soil or water column, and affects habitat and resource conditions for other organisms. Insects are the primary herbivores in many ecosystems, and their effect on primary production can equal or exceed that of more conspicuous vertebrate grazers (e.g., A. Andersen and Lonsdale 1990, Gandar 1982, A. Sinclair 1975, Weisser and Siemann 2004, Wiegert and Evans 1967).

Loss of plant material through herbivory generally is negligible, or at least inconspicuous, but periodic outbreaks of herbivores have a well-known capacity to reduce growth and survival of host species by as much as 100% and to alter vegetation structure over large areas. A key aspect of herbivory is its variation in intensity among plant species, reflecting biochemical interactions between the herbivore and the various host and non-host species that comprise the vegetation (see Chapter 3).

The effects of herbivory on ecosystem variables depend on the type of herbivore and pattern of consumption, as well as its intensity and the scale at which it is measured (B. Brown and Allen 1989, Mauricio et al. 1993). Measurement and comparison of herbivory and its effects among ecosystems and environmental conditions remain problematic, due to a lack of standardized techniques for measuring or manipulating intensity. Few studies have assessed the effects of herbivory on ecosystem processes other than primary production. Nevertheless, accumulating evidence indicates that the effects of herbivory on ecosystem processes, including upon primary production, are complex, and long-term compensatory effects may at least partially offset short-term effects. As a result, ecosystem management practices that exacerbate or suppress herbivory may be counterproductive.

## I. TYPES AND PATTERNS OF HERBIVORY

### A. Herbivore Functional Groups

Herbivorous insects that have similar means of exploiting plant parts for food can be classified into feeding guilds or functional groups. Groups of plant-feeders include **grazers** that chew foliage, stems, flowers, pollen, seeds and roots, **miners** and **borers** that feed between plant surfaces, **gall-formers** that reside and feed within the plant and induce the production of abnormal growth reactions by plant tissues, **sap-suckers** that siphon plant fluids, and **seed predators** and **frugivores** that consume the reproductive parts of plants (Romoser and Stoffalano 1998). Some species, such as seed predators, seedling-eaters, and tree-killing bark beetles, are true plant predators, but most herbivores function as plant parasites because they normally do not kill their hosts, but instead feed on the living plant without causing death (Price 1980). These different modes of consumption affect plants in different ways. For example, **folivores** (species that chew foliage) directly reduce the area of photosynthetic tissue, whereas **sap-sucking** insects affect the flow of fluids and nutrients within the plant, and **root-feeders** reduce plant capacity to acquire nutrients or remain upright.

Folivory is the best studied aspect of herbivory. In fact, the term herbivory often is used even when folivory alone is measured, because loss of foliage is the most obvious and easily-quantified aspect of herbivory. The loss of leaf area can be used to indicate the effect of herbivory. In contrast, other herbivores, such as sap-suckers or root-borers cause less conspicuous losses that are more difficult to measure. None-the-less, Schowalter et al. (1981c) reported that the calculated loss of photosynthates to sap-suckers greatly exceeded measured foliage loss to folivores in an early successional deciduous forest. Sap-suckers and root-feeders also may have long term effects, e.g., through disease transmission or altered rates of nutrient acquisition or growth (J. Smith and Schowalter 2001).

### B. Measurement of Herbivory

Effects of herbivory on ecosystem processes are determined by temporal and spatial variability in the magnitude of consumption. Clearly, evaluating the effects of herbivory requires robust methods for measuring it, as well as for measuring primary productivity and other ecosystem processes. Measurement of herbivory can be difficult, especially for underground plant parts and forest canopies, and has not been standardized. Several methods commonly used to measure herbivory have been compared by Filip et al. (1995), Landsberg (1989) and Lowman (1984).

The simplest and most widely used technique is the measurement of feeding rate by individual herbivores and extrapolation to feeding rate by a population. This technique provides relatively accurate rates of consumption, and can be used to estimate per capita feeding rate for sap-suckers as well as folivores (e.g., Gandar 1982, Schowalter et al. 1981c, B. Stadler and Müller 1996). Insect folivores typically consume 50–150% of their dry body mass per day (Blumer and Diemer 1996, Reichle and Crossley 1967, Reichle et al. 1973, Schowalter et al. 1981c).

Rates of sap and root consumption are difficult to measure, but a few studies have provided limited information. For example, honeydew production by individual sap-sucking insects can be used as an estimate of their consumption rates. Stadler and Müller (1996) and Stadler et al. (1998) reported that individual spruce aphids, *Cinara* spp., produced from 0.1 mg honeydew per day for 1<sup>st</sup> instars to 1 mg per day for adults, depending on the aphid species,

season, and nutritional status of the host. Schowalter et al. (1981c) compiled consumption data from studies of eight herb- and tree-feeding aphids (Auclair 1958, 1959, 1965, Banks and Macaulay 1964, Banks and Nixon 1959, M. Day and Irzykiewicz 1953, M. Llewellyn 1972, Mittler 1958, 1970, Mittler and Sylvester 1961, Van Hook et al. 1980, M. Watson and Nixon 1953), a leafhopper (M. Day and McKinnon 1951) and a spittlebug (Wiegert 1964) that yielded an average consumption rate of 2.5 mg dry sap mg<sup>-1</sup> dry insect da<sup>-1</sup>.

Several factors affect the rate of sap consumption. P. Andersen et al. (1992) found that the feeding rate of a leafhopper was related to xylem chemistry and fluid tension. Feeding rates generally increased with amino acid concentrations and decreased with xylem tension, ceasing above tensions of 2.1 Mpa when plants were water stressed. Stadler and Müller (1996) reported that aphids feeding on poor quality hosts with yellowing needles produced twice the amount of honeydew as did aphids feeding on high quality hosts during shoot expansion, but this difference disappeared by the end of shoot expansion. Banks and Nixon (1958) reported that aphids tended by ants approximately doubled their rates of ingestion and egestion.

Measurement of individual consumption rate has only limited utility for extrapolation to effects on plant growth, because more plant material may be lost, or not produced, than actually consumed, as a consequence of wasteful feeding or mortality of meristems (e.g., Blumer and Diemer 1996, Gandar 1982). For example, Schowalter (1989) reported that feeding on Douglas-fir, *Pseudotsuga menziesii*, buds by a budmoth, *Zeiraphera hesperiana*, caused an overall loss of < 1% of foliage standing crop, but the resulting bud mortality caused a 13% reduction in production of shoots and new foliage.

Herbivory can be estimated as the amount of frass collected per unit time (Fig. 12.1), adjusted for assimilation efficiency (Chapter 4). This measure is sensitive to conditions that affect frass collection, such as precipitation. Hence, frass generally must be collected prior to rainfall events. Mizutani and Hijii (2001) measured the effect of precipitation on frass collection in conifer and deciduous broadleaved forests in central Japan and calculated correction factors for frass distintegration due to precipitation. Such methods enhance the use of frass collection for estimation of herbivory.

Herz et al. (2007) described a method for estimating foliage harvest by leaf-cutting ants, *Atta columbica*. These insects harvest foliage for maintenance of fungal gardens in underground chambers and discard exhausted substrate in refuse piles outside the nest. Herz et al. (2007) found that the number of refuse particles deposited per day was tightly correlated with the number of harvested foliage fragments, for nests of different sizes. The number of particles, adjusted for average foliage fragment area or mass, provided an estimate of the annual rates of harvest.

Percentage of leaf area that is missing can be measured at discrete times throughout the growing season. This percentage can be estimated visually but is sensitive to observer bias (Landsberg 1989). Alternatively, leaf area of foliage samples is measured, then re-measured after holes and missing edges have been reconstructed (e.g., Filip et al. 1995, H. Odum and Ruiz-Reyes 1970, Reichle et al. 1973, Schowalter et al. 1981c). Reconstruction originally was accomplished using tape or paper cutouts. More recently, computer software has become available to reconstruct leaf outlines and fill in missing portions (Hargrove 1988). Neither method accounts for expansion of holes as leaves expand, for compensatory growth (to replace lost tissues), for completely consumed or prematurely abscised foliage, for foliage loss due to high winds, nor for herbivory by sap-suckers (Faeth et al. 1981, Hargrove 1988, Lowman, 1984; Reichle et al. 1973, Risley and Crossley, 1993, Stiling et al. 1991).



**FIG. 12.1** Insect herbivore feces collected on understory vegetation in cypress-tupelo swamp in southern Louisiana, U.S.

The most accurate method for measuring loss to folivores is a detailed life table analysis of marked leaves at different stages of growth (Aide 1993, Filip et al. 1995, Hargrove 1988, Lowman 1984). Continual monitoring can account for consumption at different stages of growth or plant development, with consequent differences in degree of hole expansion, compensatory growth, and complete consumption or loss of damaged leaves (Lowman 1984, Risley and Crossley 1993). Estimates of herbivory based on such long-term monitoring often are 3–5 times the estimates based on discrete measurement of leaf area loss (Lowman 1984, 1995). Filip et al. (1995) compared continual and discrete measurements of herbivory for 12 tree species in a tropical deciduous forest in Mexico. Continual measurement provided estimates that were 1–5 times higher than those based on discrete sampling. On average, measurements from the two techniques differed by a factor of 2. Broadleaved plants are more amenable to this technique than are needle-leaved plants.

Several methods have also been used to measure effects of herbivory on plants or ecosystem processes. A vast literature is available on the effects of herbivory on growth of individual plants or plant populations (e.g., Crawley 1983, Huntly 1991). However, most studies have focused on effects of above-ground herbivores on above-ground plant parts. Few studies have addressed root-feeding insects or root responses to herbivory (M.D. Hunter 2001a, Morón-Ríos et al. 1997b, J. Smith and Schowalter 2001, D. Strong et al. 1995). J. Smith and Schowalter (2001) and D. Strong et al. (1995) found that roots can

take at least a year to recover from herbivory, indicating that short-term experiments may be inadequate to estimate the effects of feeding on roots.

Remote sensing techniques are being developed to measure effects of herbivory, as well as various plant stressors, on a variety of plant species, from grasses to conifers and deciduous trees (Carter and Knapp 2001). In all cases, stress was expressed as a reflectance increase at wavelengths near 700 nm. This optical response can be explained by a general tendency for stress to reduce chlorophyll concentrations in foliage. Nansen et al. (2009) reported that experimental wheat stem sawfly, *Cephus cinctus*, infestation was detectable as significantly reduced reflectance at 725 nm. Normalized difference vegetation index (NDVI) and photochemical reflectance index (PRI) decreased in response to sawfly infestation, whereas stress index (SI) increased. Nansen et al. (2010) evaluated effects of severe, moderate or no drought stress or spider mite, *Tetranychus urticae*, infestation in cereal crops. They found a particularly strong response to drought (but not spider mite) stress at 706 nm and a significant response to spider mites, as well as drought stress, at 440 nm.

At the ecosystem level, a number of studies have compared ecosystem processes between sites that were naturally infested, or not infested, during population irruptions. Such comparison confounds herbivore effects with environmental gradients that may be responsible for the discontinuous pattern of herbivory (Chapter 7). Hurlbert (1984) discussed the importance of independent, geographically intermixed, replicate plots for the comparison of treatment effects. This requires manipulation of herbivore abundances in replicate plots to evaluate effects on ecosystem parameters.

Experimental manipulation of herbivore numbers has been accomplished, especially on short vegetation (e.g., Kimmins 1972, McNaughton 1979, Morón-Ríos et al. 1997a, Schowalter et al. 1991, Seastedt 1985, Seastedt et al. 1983, S. Williamson et al. 1989), but clearly is difficult in mature forests. The most common method for manipulation is chemical suppression (e.g., V.K. Brown et al. 1987, 1988, D. Gibson et al. 1990, Louda and Rodman 1996, Seastedt et al. 1983). However, insecticides can provide a source of limiting nutrients that may affect plant growth. Carbaryl, for example, contains nitrogen, frequently limiting and likely to stimulate plant growth. Furthermore, measuring resulting differences in herbivore abundance between treatments may be difficult. Herbivore abundance also can be manipulated using enclosures or exclosures (e.g., Schowalter et al. 1991, S. Williamson et al. 1989), but augmenting herbivore abundance often is difficult (I. Baldwin 1990, Crawley 1983, Schowalter et al. 1991) and may require rearing facilities to produce sufficient herbivore numbers. Cages constructed of fencing or mesh screening can exclude or contain experimental densities of herbivores (e.g., Fonte and Schowalter 2005, McNaughton 1985, Palmisano and Fox 1997). Mesh screening should be installed in a manner that does not restrict air movement or precipitation and thereby alter growing conditions within the cage.

An alternative option has been to simulate herbivory by clipping or pruning plants or by punching holes in leaves (e.g., Honkanen et al. 1994). This method avoids the problems of manipulating herbivore abundance but may fail to represent important aspects of herbivory, other than physical damage, that influence its effects (e.g., I. Baldwin 1990, Crawley 1983, Lyytikäinen-Saarenmaa 1999). For example, herbivore saliva may stimulate the growth of some plant species (M. Dyer et al. 1995), and natural patterns of consumption and frass deposition affect litter condition, decomposition and nutrient supply (Christenson et al. 2002, Frost and Hunter 2004, 2007, 2008b, Hik and Jefferies 1990, Lovett and Ruesink 1995, B. Stadler et al. 1998, Zlotin and Khodashova 1980). Lyytikäinen-Saarenmaa

(1999) reported that artificial defoliation of Scots pine, *Pinus sylvestris*, saplings caused greater growth reduction than did comparable herbivory by sawflies, *Diprion pini* and *Neodiprion sertifer*, in May–June, whereas the opposite trend was seen for trees subjected to treatments in July–August.

The choice of technique for measuring herbivory and its effects depends on several considerations. The method of measurement must be accurate, efficient, and consistent with the objectives of the study. Measurement of percentage leaf area missing at a point in time is an appropriate measure of the effect of herbivory on canopy porosity, photosynthetic capacity, and canopy–soil or canopy–atmosphere interactions, but it does not represent the rate of consumption or removal of plant material. Access to some plant parts is difficult, precluding continuous monitoring. Hence, limited data are available for herbivory on roots or in forest canopies. Simulating herbivory by removing plant parts or punching holes in leaves fails to represent some important effects of herbivory, such as salivary toxins or stimulants or flux of canopy material to litter as feces, but does overcome the difficulty of manipulating abundances of herbivore species.

Similarly, the choice of response variables depends on objectives. Most studies have examined only the effects of herbivory on above-ground primary production, consistent with emphasis on foliage and fruit production. However, herbivores feeding above ground affect root production and rhizosphere processes, as well (Gehring and Whitham 1991, 1995, Holland et al. 1996, Rodgers et al. 1995, J. Smith and Schowalter 2001). Effects on some fluxes, such as dissolved organic carbon in honeydew, are difficult to measure (B. Stadler et al. 1998). Some effects, such as compensatory growth and altered community structure, may not become apparent for long time periods following herbivore outbreaks (Alfaro and Shepherd 1991, Wickman 1980), requiring long-term measurement.

### C. Spatial and Temporal Patterns of Herbivory

All plant species support characteristic assemblages of insect herbivores, although some host a greater diversity of herbivores and exhibit higher levels of herbivory than do others (e.g., Coley and Aide 1991, de la Cruz and Dirzo 1987). Some plants tolerate continuous, high levels of herbivory, whereas other species show negligible loss of plant material (S. Carpenter and Kitchell 1984, Lowman and Heatwole 1992, McNaughton 1979, Schowalter and Ganio 2003), and some plant species suffer mortality at lower levels of herbivory than do others. Herbivory typically is concentrated on the most nutritious or least defended plants and plant parts (Chapter 3, Aide and Zimmerman 1990).

The consequences of herbivory vary significantly, not just among plant–herbivore interactions, but also as a result of different spatial and temporal factors (Huntly 1991, Maschinski and Whitham 1989). For example, water or nutrient limitation and ecosystem fragmentation can significantly affect the ability of the host plant to respond to herbivory (e.g., Chapin et al. 1987, Kolb et al. 1999, Maschinski and Whitham 1989, W. Webb 1978). The timing of herbivory in relation to plant development and the intervals between attacks also have important effects on ecosystem processes (Hik and Jefferies 1990).

Herbivory usually is expressed as daily or annual rates of consumption and ranges from negligible to several times the standing crop biomass of foliage (Table 12.1), depending on ecosystem type, environmental conditions, and regrowth capacity of the vegetation (Lowman 1995, Schowalter and Lowman 1999). Herbivory for particular plant species can be integrated at the ecosystem level by weighting rates for each plant species by its biomass

**TABLE 12.1** Herbivory measured in temperate and tropical ecosystems (including understory).

Location	Ecosystem type	Level of grazing	Technique*	Source
<b>Tropical</b>				
Costa Rica	Tropical forest	7.5% (new leaves)	1	N. Stanton (1975)
	Tropical evergreen forest	30% (old)	1	N. Stanton (1975)
Panama	Tropical evergreen forest	13%	1	Wint (1983)
Panama (BCI)	Tropical evergreen forest	8% (6% insects; 1–2% vertebrates)	1, 2	Leigh and Smythe (1978)
		15%	1, 2	Leigh and Windsor (1982)
Puerto Rico	Understory only	21% (but up to 190%)	3	Coley (1983)
	Tropical evergreen forest	7.8%	1	H. Odum and Ruíz-Reyes (1970)
		5.5–16.1%	1	Benedict (1976)
Mexico	Tropical deciduous forest	2–6%	1	Schowalter (1994)
		2–13%	1	Schowalter and Ganio (1999)
		7–9%	1	Filip et al. (1995)
Venezuela	Tropical deciduous forest	17%	3	Filip et al. (1995)
Venezuela	Understory only	0.1–2.2%	1	Golley (1977)
New Guinea	Tropical evergreen forest	9%–12%	1	Wint (1983)
Australia	Montane or cloud forest	26%	3	Lowman (1984)
	Warm temperate forest	22%	3	Lowman (1984)
	Subtropical forest	14.6%	3	Lowman (1984)
Cameroon	Tropical evergreen forest	8–12%	3	Lowman et al. (1993)

Location	Ecosystem type	Level of grazing	Technique*	Source
Tanzania	Tropical grassland	14–38% (4–8% insect; 8–34% vertebrates)	4	A. Sinclair (1975)
South Africa	Tropical savanna	38% (14% insect; 24% vertebrates)	4	Gandar (1982)
<b>Temperate</b>				
North America	Deciduous forest	2–10%	1	Reichle et al. (1973)
		1–5%	1	Schowalter et al. (1981c)
	Herbaceous sere	3%	4	Crossley and Howden (1961)
	Coniferous forest	<1%	1	Schowalter (1989)
		1–6%	1	Schowalter (1995)
Australia	Grassland	5–15%	1	Detling (1987)
	Evergreen forest	15–300%	3	Lowman and Heatwole (1992)
		Dry forest	5–44%	1
			3–6%	2
Europe	Deciduous forest	7–10%	1	Nielsen (1978)
	Alpine grassland	19–30%	1	Blumer and Diemer (1996)

\*1 = Leaf area missing, 2 = litter or frass collection, 3 = turnover of marked foliage, 4 = individual consumption rates.

Expanded from Lowman (1995)



or leaf area. When the preferred hosts are dominant plant species, loss of plant parts can be dramatic and conspicuous, especially if these species are slow to replace lost parts (B. Brown and Ewel 1987). For example, defoliation of evergreen forests may be visible for months, whereas deciduous forests and grasslands are adapted for periodic replacement of foliage and typically will replace lost foliage quickly. Eucalypt forests are characterized by chronically high rates of herbivory (Fox and Morrow 1992). Some species lose more than 300% of their foliage standing crop annually, based on life table studies of marked leaves (Lowman and Heatwole 1992).

Comparison of herbivory among ecosystem types (Table 12.1) indicates considerable variation. The studies in Table 12.1 reflect the range of measurement techniques described above. Most are short-term snapshots of folivory, often for only a few plant species, do not provide information on herbivory by sap-suckers or root-feeders, and do not address any deviation in environmental conditions, plant chemistry, or herbivore densities from long-term means during the period of study. Long-term studies using standardized techniques are necessary for meaningful comparison of herbivory rates.

Cebrián and Duarte (1994) compiled data from a number of aquatic and terrestrial ecosystems and found a significant relationship between the percentage of plant material consumed by herbivores and the rate of primary production. Herbivory ranged from negligible to more than 50% of photosynthetic biomass removed daily. Rates were greatest in some phytoplankton communities where herbivores consumed the entire daily production, and were least in some forests where herbivores removed less than 1% of production. Insects are the primary herbivores in forest ecosystems (Janzen 1981, Wiegert and Evans 1967) and account for 11–73% of total herbivory in grasslands, where native vertebrate herbivores remove an additional 15–33% of production (Detling 1987, Gandar 1982, A. Sinclair 1975). Temperate deciduous forests and tropical evergreen forests show similar annual losses of 3–20%, based on discrete sampling of leaf area loss (Coley and Aide 1991, Landsberg and Ohmart 1989, H. Odum and Ruíz-Reyes 1970, Schowalter and Ganio 1999, Schowalter et al. 1986, Van Bael et al. 2004). Aquatic ecosystems, evergreen forests and grasslands, which replace lost photosynthetic tissue continuously, often lose several times their standing crop biomass to herbivores annually, based on loss of marked foliage or on herbivore exclusion (Carpenter and Kitchell 1984, Cebrián and Duarte 1994, Crawley 1983, Landsberg 1989, Lowman and Heatwole 1992, McNaughton 1979).

In addition to the conspicuous loss of photosynthetic tissues, terrestrial plants lose additional material to sap-suckers and root-feeders. Schowalter et al. (1981c) compiled data on rates of sap consumption, and estimated a turnover of 5–23% of foliage standing crop biomass through sap-sucking herbivores, in addition to 1–2% turnover through folivores, in a temperate deciduous forest. J. Smith and Schowalter (2001) found that shoot-feeding aphids, *Cinara pseudotsugae*, significantly reduced root tissue density and growth in Douglas-fir, and that at least one year was required for recovery after feeding ceased. V.K. Brown and Gange (1991) and Morón-Ríos et al. (1997a) reported that root-feeding insects can reduce primary production of grasses by 30–50%.

Factors that promote herbivore population growth, e.g., abundant and susceptible hosts, also increase herbivory (see Chapters 6 and 8). Proportional losses of foliage to folivores generally are higher in less diverse ecosystems, compared to more diverse ecosystems (Jactel and Brockerhoff 2007, Kareiva 1983), but the intensity of herbivory also depends on the particular species composition of the vegetation (R. Moore and Francis 1991, R. Moore et al. 1991). B. Brown and Ewel (1987) demonstrated that ecosystem-level foliage losses per unit ground area were similar among four tropical ecosystems that

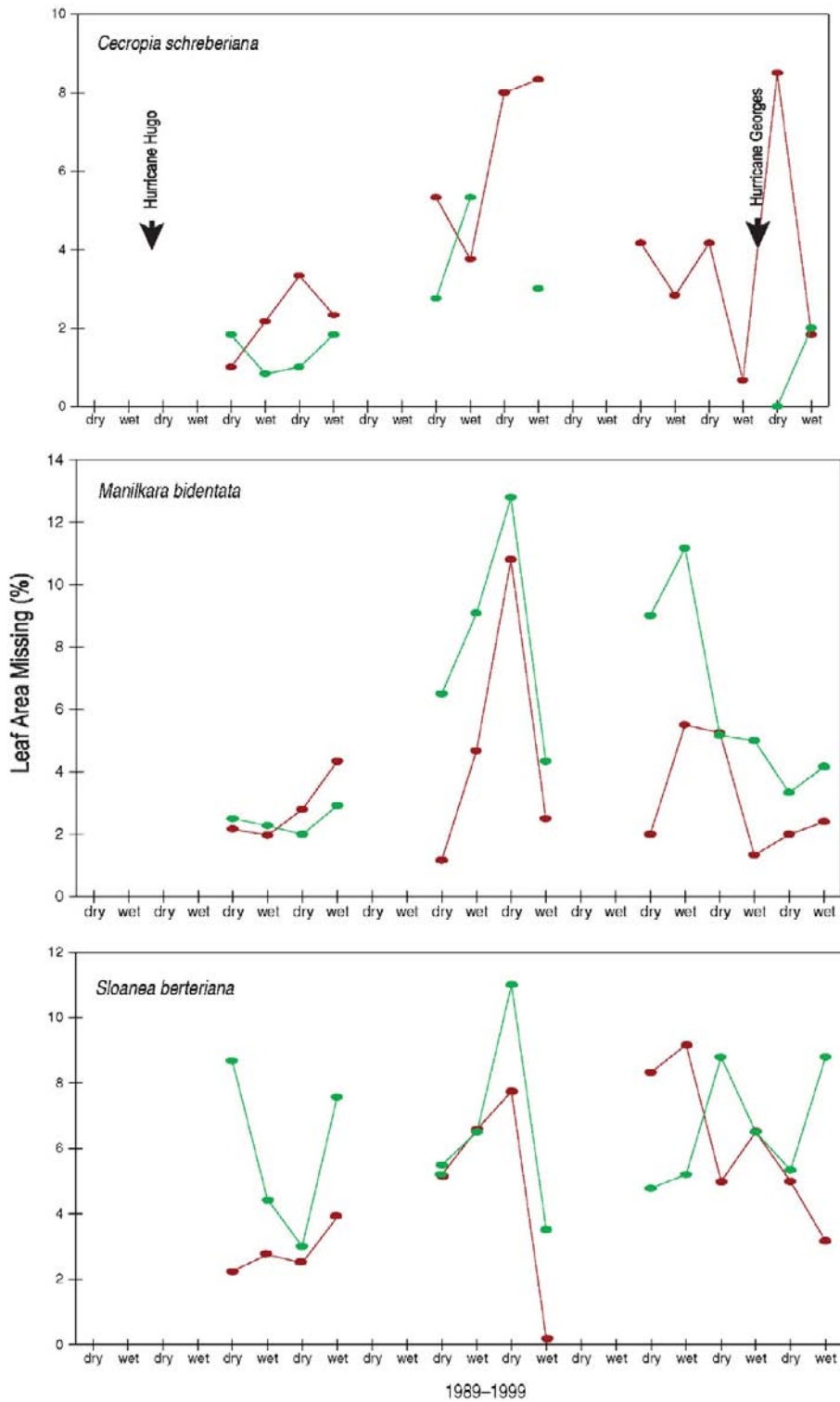
varied in vegetation diversity, but the proportional loss of foliage standing crop was highest in the less diverse ecosystems. Nevertheless, rare plant species in diverse ecosystems can suffer intense herbivory, especially under conditions that increase their apparency or acceptability (B. Brown and Ewel 1987, Schowalter and Ganio 1999). C. Fonseca (1994) reported that an Amazonian myrmecophytic canopy tree showed 10-fold greater foliage losses when ants were experimentally removed than when ants were present.

Disturbances alter rates of herbivory. Droughts and storms are well-known triggers for elevated herbivore populations (Mattson and Haack 1987, Van Bael et al. 2004, see Chapters 2 and 6) and consequent herbivory. Harvesting a forest also can affect rate and pattern of herbivory. Urbas et al. (2007) found that colonies of a leaf-cutting ant, *Atta cephalotes*, at forest edges removed nearly twice the amount of foliage from their foraging area as did colonies in interior forest (14% vs. 8%). The higher level of herbivory reflected significantly smaller foraging areas for edge, compared to interior, colonies (0.9 vs. 2.3 ha colony<sup>-1</sup> yr<sup>-1</sup>) and perhaps greater productivity of pioneer tree species at the edges.

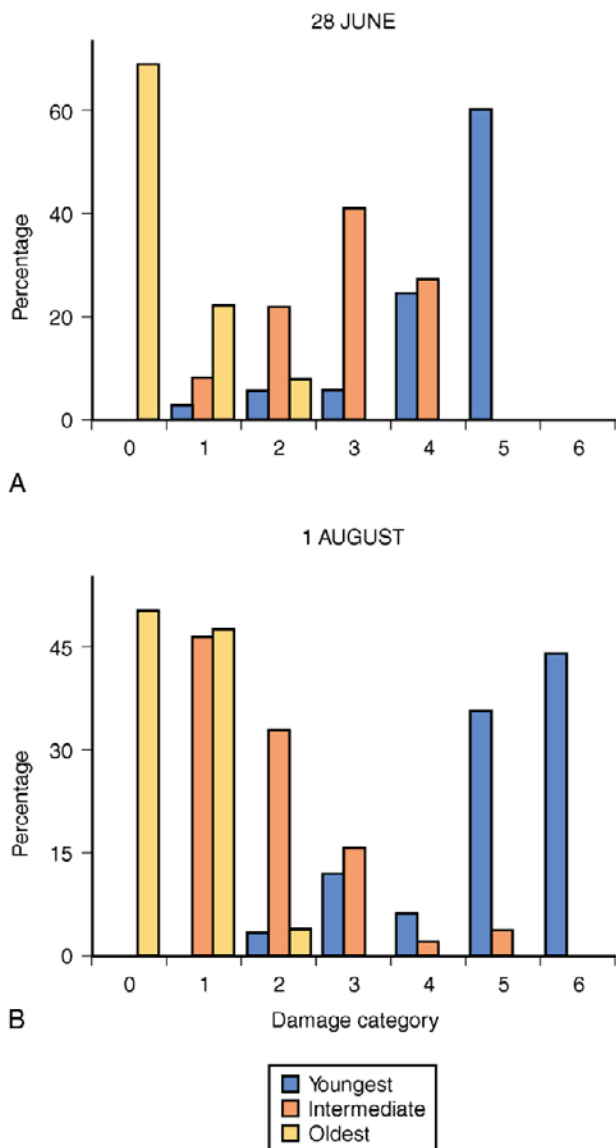
Seasonal and annual changes in herbivore abundance affect patterns and rates of herbivory, but the relationship may not be linear, depending on variation in per capita rates of consumption or wasteful feeding with increasing population density (Crawley 1983, B. Stadler et al. 1998). Herbivory in temperate forests typically is concentrated in the spring, during leaf expansion (Feeny 1970, M.D. Hunter 1987). M.D. Hunter (1992) reported that over 95% of total defoliation on *Quercus robur* in Europe occurs between budburst in April and the beginning of June. Although some herbivorous insects prefer mature foliage (Cates 1980, Sandlin and Willig 1993, Volney et al. 1983), most defoliation events are associated with young foliage (Coley 1980, M.D. Hunter 1992, R. Jackson et al. 1999, Lowman 1985). Herbivory also is highly seasonal in tropical ecosystems. Tropical plants produce new foliage over a more protracted period than do temperate plants, but many produce new foliage in response to seasonal variation in precipitation (Aide 1992, Coley and Aide 1991, Lowman 1992, Ribeiro et al. 1994). Young foliage may be grazed more extensively than older foliage in tropical rainforests (Coley and Aide 1991, Lowman 1984, 1992). Schowalter and Ganio (1999) reported significantly greater rates of leaf area loss during the “wet” season than during the “dry” season in a tropical rain forest in Puerto Rico (Fig. 12.2). However, seasonal peaks of leaf expansion and herbivory are broader in tropical ecosystems than in temperate ecosystems.

Few studies have addressed long-term changes in herbivore abundances or herbivory as a result of environmental changes (see Chapter 6). However, disturbances often induce elevated rates of herbivory at a site. Periods of elevated herbivory frequently are associated with drought (Mattson and Haack 1987, Van Bael et al. 2004, Chapter 6). Although herbivore outbreaks are typically associated with temperate forests, Van Bael et al. (2004) documented a general outbreak by several lepidopteran species on multiple tree and liana species during an El Niño-induced drought in Panama. Torres (1992) reported outbreaks of several lepidopteran species on understory forbs and vines following Hurricane Hugo in Puerto Rico. These studies suggest that outbreaks may be common but less conspicuous in tropical forests. Other disturbances that injure plants also may increase herbivory, especially by root feeders and stem borers (e.g., T. Paine and Baker 1993, Witcosky et al. 1986).

Changes in vegetation which are associated with disturbance or recovery affect temporal patterns of herbivory. Bach (1990) reported that intensity of herbivory declined during succession in dune vegetation in Michigan (Fig. 12.3). Coley (1980, 1982, 1983), Coley and Aide (1991), and Lowman and Box (1983) found that rapidly-growing, early successional



**FIG. 12.2** Effects of tree species, hurricane disturbance, and seasonal cycles on leaf area missing in a tropical rain forest in Puerto Rico, as affected by two hurricanes (1989 and 1998) and a drought (1994–95). *Cecropia* is an early successional tree; *Manilkara* and *Sloanea* are late successional trees. Green lines represent intact forest (lightly disturbed); red lines represent treefall gaps.



**FIG. 12.3** Herbivore damage to plants in young, intermediate and old successional sites in sand dune vegetation in Michigan in June (A) and August (B) 1988. Percentages are averages for leaves on upper and lower canopy branches by damage category: 0=0% damage, 1=1–5%, 2=6–25%, 3=26–50%, 4=51–75%, 5=76–100%, and 6=no leaves remaining. From Bach (1990) with permission from the Ecological Society of America.

tree species showed higher rates of herbivory than did slow-growing, late successional trees. Schowalter (1995), Schowalter and Ganio (1999, 2003) and Schowalter and Crossley (1988) compared canopy herbivore abundances and folivory in replicated disturbed (harvest or hurricane) and undisturbed patches of temperate deciduous, temperate coniferous and tropical evergreen forests. In all three forest types, disturbance resulted in greatly increased abundances of sap-suckers and somewhat increased abundances of folivores

on abundant, rapidly-growing early successional plant species. The shift in biomass dominance from folivores to sap-suckers following disturbance resulted in an elevated flux of primary production as soluble photosynthates, relative to fragmented foliage and feces. Schowalter et al. (1981c) calculated that loss of photosynthate to sap-suckers increased from 5% of foliage standing crop in undisturbed forest to 20–23% of foliage standing crop during the first two years following clearcutting, compared to relatively consistent losses of 1–2% to folivores. Torres (1992) reported a sequence of defoliator outbreaks on early successional herbs and shrubs during several months following Hurricane Hugo in Puerto Rico. As each plant species became dominant at a site, severe defoliation facilitated its replacement by other plant species. Continued measurement of herbivory over long time periods will be necessary to relate changes in the intensity of herbivory to environmental changes and to effects on ecosystem processes.

## II. EFFECTS OF HERBIVORY

Herbivory affects a variety of ecosystem properties, primarily through differential changes in survival, productivity, and growth form among plant species. Herbivory is not evenly distributed among plant species or over time. Rather, some species are subject to greater herbivory than are others, and relative herbivory among plant species varies with environmental conditions (e.g., Coley 1980, Coley and Aide 1991, Crawley 1983, Schowalter and Ganio 1999, see [Chapter 3](#)). These differential effects on host conditions alter vegetation structure, energy flow and biogeochemical cycling, and often predispose the ecosystem to characteristic disturbances.

The observed severity of herbivore effects in agroecosystems and some native ecosystems has led to a widespread perception of herbivory as a disturbance (see [Chapter 2](#)). This perception raises a number of issues. How can a normal trophic process also be a disturbance? At what level does herbivory become a disturbance; e.g., do the normally low levels of 5–20% loss of NPP constitute disturbance? Although debate may continue over whether or not herbivory is a disturbance (Veblen et al. 1994, P. White and Pickett 1985), rather than simply an ecosystem process (Schowalter 1985, Schowalter and Lowman 1999, Willig and McGinley 1999), herbivory can dramatically alter ecosystem structure and function over large areas.

### A. Plant Productivity, Survival and Growth Form

Traditionally, herbivory has been viewed solely as a process that reduces primary production. As described above, herbivory can remove several times the standing crop of foliage, alter plant growth form, or kill all plants of selected species over large areas during severe outbreaks. However, several recent studies indicate that herbivory has more complex effects. The degree to which herbivory affects plant survival, productivity and growth form depends on the plant parts affected, plant condition, including the stage of plant development, and the intensity of herbivory.

Different herbivore species and functional groups, e.g., folivores, sap-suckers, shoot-borers and root-feeders, determine which plant parts are affected. Folivores and leaf miners reduce foliage surface area and photosynthetic capacity, thereby limiting the ability of the plant to produce and accumulate photosynthates for growth and maintenance (R. Doyle et al. 2002). In addition to direct consumption of foliage, much non-consumed foliage is lost, due to wasteful feeding by folivores (Risley and Crossley 1993) and induction

of leaf abscission by leaf miners (Faeth et al. 1981, Stiling et al. 1991). Sap-suckers and gall-formers siphon photosynthates from the plant's vascular system and reduce plant ability to accumulate resources for growth and maintenance. Shoot-borers and bud-feeders damage meristems and growing shoots, thereby altering plant growth rate and form (A. Martínez et al. 2009). Root-feeders reduce plant ability to acquire water and nutrients and weaken plant support (Blossey and Hunt-Joshi 2003). Reduced accumulation of energy often reduces flowering, pollination or seed production (Quesada et al. 1995, Simard and Payette 2005), often completely precluding reproduction (V.K. Brown et al. 1987, Crawley 1989). For example, M. Parker (1985) and Wisdom et al. (1989) reported that flower production by composite shrubs, *Gutierrezia microcephala*, was reduced as much as 80% as a consequence of grazing by the grasshopper, *Hesperotettix viridis*. Many sap-suckers and shoot-and root-feeders also transmit or facilitate the growth of plant pathogens, including viruses, bacteria, fungi and nematodes (e.g., C.G. Jones 1984). Alternatively, folivory may induce resistance to subsequent infection by plant pathogens (Hatcher et al. 1995).

Plant condition is affected by developmental stage and environmental conditions and determines herbivore population dynamics (see Chapters 3 and 6) and plant capacity to compensate for herbivory. Low or moderate levels of herbivory often increase photosynthesis and stimulate plant productivity (e.g., E. Ayres et al. 2007, Belovsky and Slade 2000, Carpenter and Kitchell 1984, Carpenter et al. 1985, C. Carroll and Hoffman 1980, Detling 1987, 1988, Dungan et al. 2007, M. Dyer et al. 1993, Kolb et al. 1999, Lowman 1982, McNaughton 1979, 1993a, Pedigo et al. 1986, Trumble et al. 1993, S. Williamson et al. 1989), whereas severe herbivory usually results in mortality or decreased fitness (Detling 1987, 1988, Marquis 1984, S. Williamson et al. 1989). Healthy plants can replace lost foliage, resulting in higher annual primary production, although standing crop biomass of plants typically is reduced.

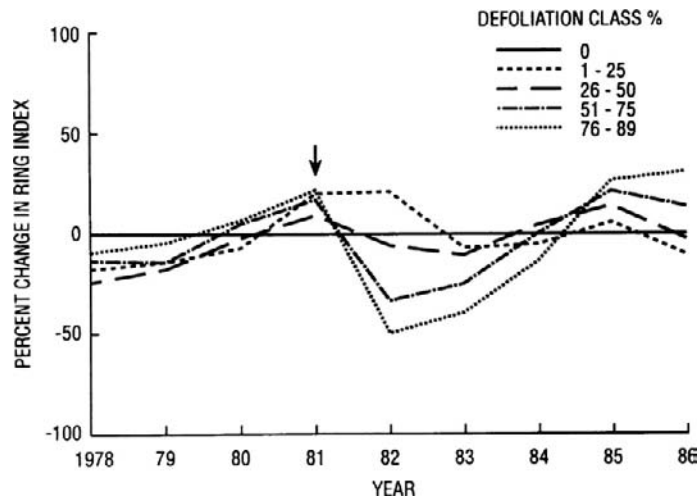
Kolb et al. (1999) experimentally evaluated a number of factors that potentially influence the effect of defoliation by the western spruce budworm, *Choristoneura occidentalis*, on the physiology and growth of potted Douglas-fir seedlings. They demonstrated that seedling biomass decreased, but photosynthetic rate, stomatal conductance, foliar concentrations of N, Ca and Mg, and soil water potential increased with increasing intensity of herbivory. Increased photosynthesis and reduced water stress may improve tree survival in environments where water stress has a more serious negative effect on survival than does defoliation. Pearson et al. (2003) evaluated factors that influenced growth and mortality of six species of pioneer trees, in forest gaps of different sizes in Panama. They found that herbivory varied from 2% to 10% overall, with *Croton bilbergianus* showing levels of 5–30%. Most species showed a trend of increasing leaf area loss with increasing gap size, but the fastest growing species did not have the highest levels of herbivory. The variation in growth rate and mortality of these plant species could not be explained by foliage losses to herbivores, but was strongly influenced by a trade-off between maximum growth in the wet season and ability to survive seasonal drought, particularly in small gaps.

The rapid replacement of primary production lost to herbivores in many aquatic systems is well-known (Carpenter and Kitchell 1984, 1987, 1988, Carpenter et al. 1985, J. Wallace and O'Hop 1985). J. Wallace and O'Hop (1985) reported that new leaves of waterlilies, *Nuphar luteum*, disappeared within three weeks as a result of grazing by the leaf beetle, *Pyrrhalta nymphaeae*. A high rate of leaf production was necessary to maintain macrophyte biomass. R. Doyle et al. (2002) concluded that 10–30% foliage removal reduced maximum daily photosynthesis by 30–40%, relative to controls, to levels

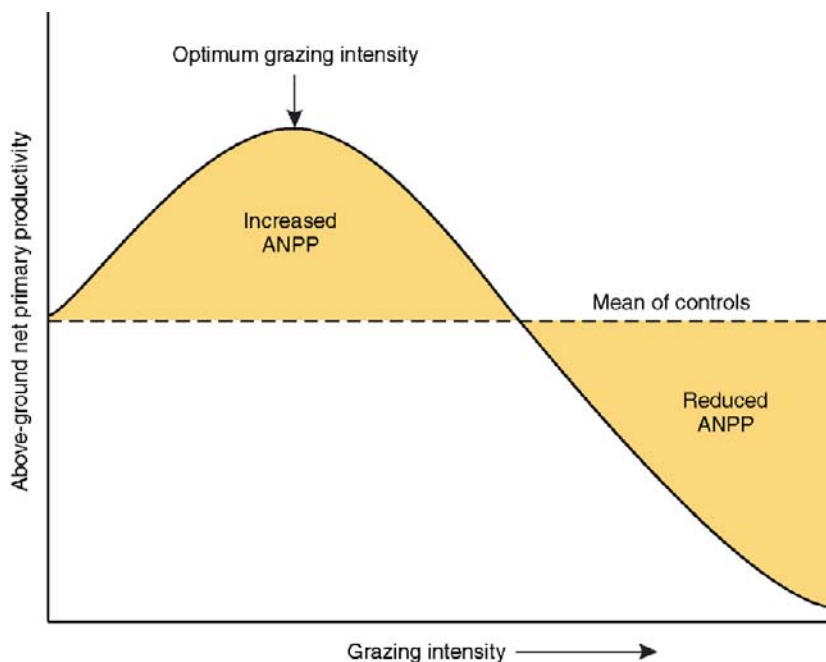
just adequate to balance respiration; 70–90% foliage removal reduced maximum daily photosynthesis by 60%, to levels less than necessary to balance respiration, making the survival of these plants unlikely.

Trumble et al. (1993) reviewed literature which demonstrated that compensatory growth (replacement of consumed tissues) following low-to-moderate levels of herbivory is a widespread response by terrestrial plants, as well. Increased productivity of grazed grasses, compared to ungrazed grasses, has been demonstrated experimentally in a variety of grassland ecosystems (Belovsky and Slade 2000, Detling 1987, 1988, McNaughton 1979, 1986, 1993a, Seastedt 1985, S. Williamson et al. 1989), but growth enhancement may depend on the presence of herbivore feces (I. Baldwin 1990, Christenson et al. 2002, Frost and Hunter 2007, Hik and Jefferies 1990) or other herbivore products (I. Baldwin 1990). M. Dyer et al. (1995) demonstrated that crop and midgut extracts present in grasshopper regurgitants during feeding stimulate coleoptile growth in grasses, but saliva may not stimulate growth of all plant species (Detling et al. 1980). Wickman (1980) and Alfaro and Shepherd (1991) reported that short-term growth losses by defoliated conifers were followed by several years, or even decades, of growth rates that exceeded pre-defoliation rates (Fig. 12.4). Romme et al. (1986) found that annual wood production in some pine forests in western North America reached or exceeded pre-attack levels within 10–15 years following mountain pine beetle, *Dendroctonus ponderosae*, outbreaks.

Detling (1987, 1988), M. Dyer et al. (1993, 1995), McNaughton (1979, 1986, 1993a) and Paige and Whitham (1987) have argued that herbivory may benefit some plants, to the extent that species that are adapted to replace consumed tissues often disappear in the absence of grazing. The net primary productivity of some grasslands declines when grazing is precluded, due to smothering of shoots as standing dead material accumulates (Kinyamario and Imbamba 1992, Knapp and Seastedt 1986, McNaughton 1979). D. Inouye (1982) reported that herbivory by several insect and mammalian herbivores had a variety of positive and negative effects on fitness of a thistle, *Jurinea mollis*.



**FIG. 12.4** Changes in ring width indices for Douglas-fir defoliated at different intensities by the Douglas-fir tussock moth, *Orgyia pseudotsugata*, in 1981 (arrow). The horizontal line at 0% represents ring width index for non-defoliated trees. From R. Alfaro and Shepherd (1991) with permission from the Society of American Foresters.



**FIG. 12.5** Relationship between intensity of herbivory and net primary production. Net primary production often peaks at low-to-moderate intensities of herbivory, supporting the grazing optimization hypothesis. From S. Williamson et al. (1989) with permission from the Society for Range Management.

These observations generated the **herbivore optimization hypothesis** (Fig. 12.5), or **overcompensation hypothesis**, which states that primary production is maximized at low-to-moderate levels of herbivory (Carpenter and Kitchell 1984, Mattson and Addy 1975, McNaughton 1979, Pedigo et al. 1986). This hypothesis is widely recognized among aquatic ecologists as the basis for inverted biomass pyramids (Carpenter and Kitchell 1984, 1987, 1988, Carpenter et al. 1985). Its application to terrestrial systems has been challenged (e.g., Belsky 1986, E. Painter and Belsky 1993, D. Patten 1993) but has been supported by experimental tests for both insect and vertebrate herbivores in grassland (Belovsky and Slade 2000, Detling 1987, M. Dyer et al. 1993, McNaughton 1979, 1993b, Seastedt 1985), salt marsh (Hik and Jefferies 1990), forest (Dungan et al. 2007, Feeley and Terborgh 2005, Lovett and Tobiesen 1993, Schowalter et al. 1991), and even agricultural (Pedigo et al. 1986), ecosystems.

Compensatory growth probably depends on environmental conditions, the availability and balances of limiting nutrients, the timing of herbivory, and plant adaptation to herbivory (de Mazancourt et al. 1998, Loreau 1995, Trlica and Rittenhouse 1993, S. Williamson et al. 1989). C. Lovelock et al. (1999) demonstrated that  $\text{CO}_2$  enrichment did not enhance compensation by a tropical legume, *Copaifera aromatica*, compared to compensation under ambient atmospheric  $\text{CO}_2$ , following artificial defoliation in Panama. Rastetter et al. (1997) used a multi-element model to demonstrate that the response of a plant to  $\text{CO}_2$  enrichment could be constrained by nitrogen limitation. De Mazancourt et al. (1998) and Loreau (1995) used a theoretical model to study conditions under which grazing optimization could occur. They found that grazing optimization required that moderate herbivory

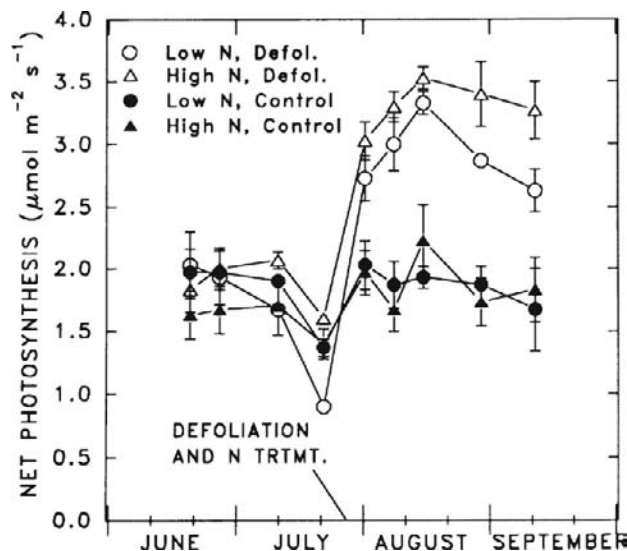


decreased nutrient losses from the system. They concluded that grazing optimization is most likely to occur in ecosystems with large losses of limiting nutrients during decomposition or where herbivores import nutrients from outside the ecosystem.

Plants often are able to compensate for herbivory in the spring, when conditions favor plant productivity, but become less able to compensate later in the season (Akiyama et al. 1984, Hik and Jefferies 1990, Thompson and Gardner 1996). Grasshoppers, *Aulocara elliotti*, did not significantly reduce standing crop of blue grama grass, *Bouteloua gracilis*, when feeding occurred early in the growing season but significantly reduced standing crop when feeding occurred later in southwestern New Mexico, U.S. (Thompson and Gardner 1996).

M. Dyer et al. (1991) reported that grazing-adapted and non-grazing-adapted clones of an African  $C_4$  grass, *Panicum coloratum*, differed significantly in their responses to herbivory by grasshoppers. After 12 weeks of grazing, the grazing-adapted plants showed a 39% greater photosynthetic rate and 26% greater biomass, compared to the non-grazing-adapted plants. Lovett and Tobiessen (1993) found that experimental defoliation resulted in elevated photosynthetic rates of red oak, *Quercus rubra*, seedlings grown under conditions of low and high nitrogen availability, but that seedlings in the high nitrogen treatment were able to maintain high photosynthetic rates for a longer time (Fig. 12.6). Vanni and Layne (1997) reported that consumer-mediated nutrient cycling strongly affected phytoplankton production and community dynamics in lakes.

Honkanen et al. (1994) artificially damaged needles or buds of Scots pine. Damage to buds increased shoot growth. Damage to needles either stimulated or suppressed shoot growth, depending on the degree and timing of damage and the position of the shoot relative to damaged shoots. Growth was significantly reduced by loss of 100%, but not 50%, of needles and was significantly reduced on shoots that were located above damaged shoots, especially late in the season. Shoots located below damaged shoots showed increased growth. Honkanen et al. (1994) suggested that these differing effects of injury



**FIG. 12.6** Mean net photosynthetic rate in old leaves from plants subjected to four combinations of nitrogen fertilization and defoliation intensity. Defoliation and fertilization treatments began July 26. From Lovett and Tobiessen (1993) with permission from Oxford University Press.

indicated an important effect of physiological status of the damaged part, i.e., whether it was a sink (bud) or source (needle) for resources.

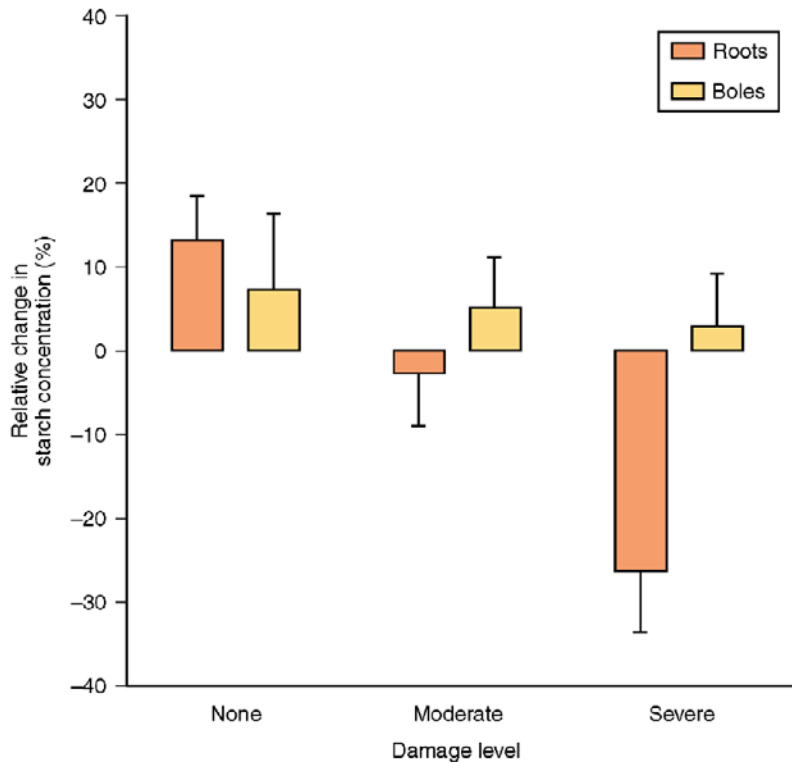
Morón-Ríos et al. (1997a) reported that below-ground herbivory by root-feeding scarab beetle larvae, *Phyllophaga* sp., prevented compensatory growth in response to above-ground grazing. Furthermore, salivary toxins or plant pathogens injected into plants by some sap-sucking species can cause necrosis of plant tissues (C.G. Jones 1984, Miles 1972, Raven 1983, Skarmoutsos and Millar 1982), accumulation of honeydew on foliage can promote the growth of pathogenic fungi and limit photosynthesis (Dik and van Pelt 1993), and some leaf miners induce premature abscission (Chabot and Hicks 1982, Faeth et al. 1981, Pritchard and James 1984a, b, Stiling et al. 1991), thereby exacerbating the direct effects of herbivory. However, foliage injury can induce resistance to subsequent herbivory or infection by plant pathogens (Hatcher et al. 1995, M.D. Hunter 1987, Karban and Baldwin 1997, see Chapters 3 and 8)

Although primary productivity may be increased by low-to-moderate intensities of grazing, some plant tissues may be sacrificed by plant allocation of resources to replace lost foliage. Morrow and LaMarche (1978) and Fox and Morrow (1992) reported that incremental growth of *Eucalyptus* stems treated with insecticide was 2–3 times greater than that of unsprayed stems.

Root growth and starch reserves are affected significantly by above-ground, as well as below-ground, herbivory. Morón-Ríos et al. (1997a) noted that root-feeders reduced root-to-shoot ratios by 40% and live-to-dead above-ground biomass ratio by 45% through tiller mortality, apparently reducing plant capacity to acquire sufficient nutrients for shoot production. Rodgers et al. (1995) observed that starch concentrations in roots were related inversely to the level of mechanical damage to shoots of a tropical tree, *Cedrela odorata* (Fig. 12.7). Gehring and Whitham (1991, 1995) reported that folivory on piñon pine adversely affected mycorrhizal fungi, perhaps through reduced carbohydrate supply to roots. However, Holland et al. (1996) reported that grasshopper grazing on maize increased carbon allocation to the roots. McNaughton (1979, 1993a) and van der Maarel and Titlyanova (1989) concluded that sufficient shoot biomass to maintain root function is critical to plant ability to compensate for losses to herbivores.

Levels of herbivory that exceed plant ability to compensate lead to growth reduction, stress, and mortality. Seedlings are particularly vulnerable to herbivores because of their limited resource storage capacity, and they may be unable to replace tissues lost to herbivores (P. Hulme 1994, Wisdom et al. 1989). D. Clark and Clark (1985) reported that survival of tropical tree seedlings was highly correlated with the percentage of original leaf area present one month after germination and with the number of leaves present at seven months of age. Continued grazing during periods of reduced plant productivity generally exacerbates stress. Resource-limited plants are more likely to succumb to herbivores than are plants with optimal resources (Belovsky and Slade 2000, Lovett and Tobiessen 1993). Plant species that are most stressed by adverse conditions suffer severe mortality to herbivores (e.g., Crawley 1983, E. Painter and Belsky 1993, Schowalter and Lowman 1999). Wright et al. (1986) found that Douglas-fir beetle, *Dendroctonus pseudotsugae*, and fir engraver beetle, *Scolytus ventralis*, preferentially colonized Douglas-fir trees that had lost > 90% of foliage to the Douglas-fir tussock moth, although larval survival was greater in non-defoliated than in defoliated trees. However, Kolb et al. (1999) demonstrated that intense defoliation could reduce moisture stress during dry periods (see above).

Herbivory by exotic species may cause more severe or more frequent reduction in productivity and survival, in part because plant defenses may be less effective against newly



**FIG. 12.7** Effect of intensity of artificial herbivory (to simulate terminal shoot damage by a lepidopteran, *Hypsipyla grandella*) on mean relative change (+ standard error) in starch concentrations (percent of initial level) in roots and lower boles of a neotropical hardwood, *Cedrela odorata*, in Costa Rica. In the moderate treatment, 0.2–0.3 cm of terminal shoot was excised; in the severe treatment, 0.5–0.6 cm of terminal was excised. Data represent five sampling dates over a 12 day period beginning 18 days after treatment. From Rodgers et al. (1995) with permission from the Association of Tropical Biologists.

associated herbivores. The most serious effects of herbivory, however, result from artificially high intensities of grazing by livestock or game (Oesterheld et al. 1992, D. Patten 1993). Whereas grazing by native herbivores is typically seasonal, and grasses have sufficient time to replace lost tissues before grazing resumes, grazing by exotic species may be more continuous, allowing insufficient time for recovery (McNaughton 1993a, Oesterheld and McNaughton 1988, 1991, Oesterheld et al. 1992).

Herbivory also can alter plant architecture, potentially influencing future growth and susceptibility to herbivores. Gall-formers deform expanding foliage and shoots. Repeated piercing during feeding-site selection by sap-sucking species also can cause deformation of foliage and shoots (Miles 1972, Raven 1983). Shoot-borers and bud-feeders kill developing shoots and induce growth of lateral shoots (D. Clark and Clark 1985, Nielsen 1978, Reichle et al. 1973, Zlotin and Khodashova 1980). Severe or repeated herbivory of this type often slows or truncates vertical growth and promotes proliferation of lateral branches (A. Martínez et al. 2009). Gange and Brown (1989) reported that herbivory increased variation in plant size. Morón-Ríos et al. (1997a) found that both above- and below-ground herbivory alter shoot-to-root ratios. Suppression of height or root growth

restricts the ability of the plant to acquire resources and often leads to plant death. However, pruning also can stimulate growth and seed production (e.g., D. Inouye 1982) or improve water and nutrient balance (e.g., Kolb et al. 1999, W. Webb 1978).

## B. Community Dynamics

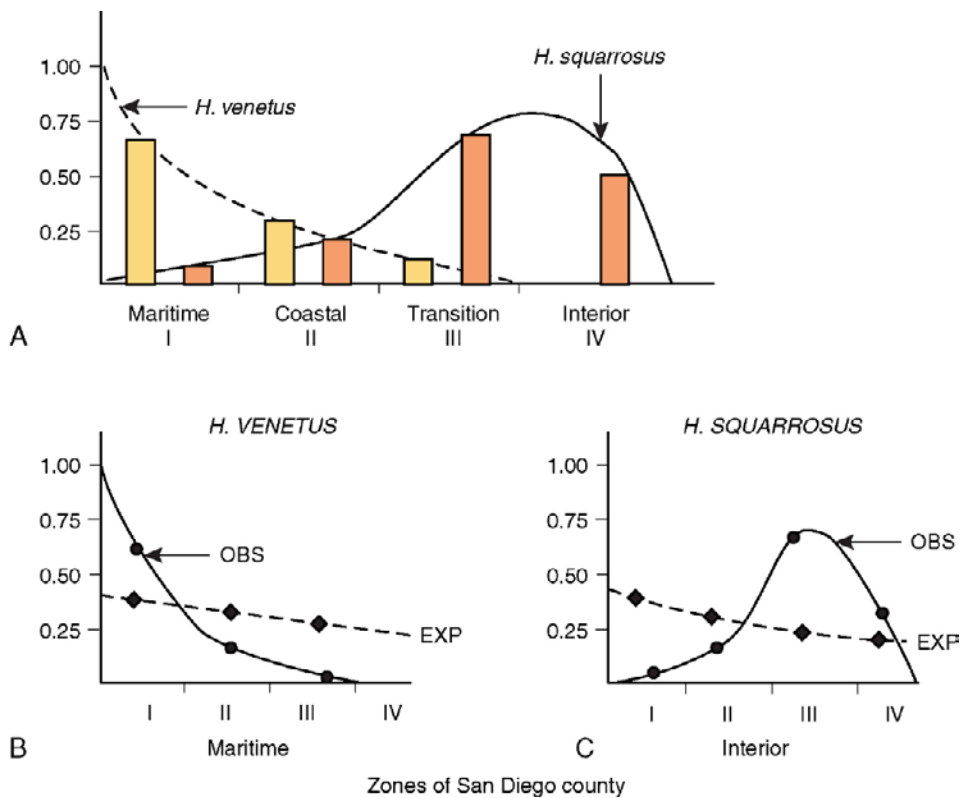
Differential herbivory among plants and plant species in an ecosystem affects both the distribution of individuals of a particular plant species and the opportunities for growth of plant species which are resistant to or tolerant of herbivory. The intensity of herbivory determines its effects on plant communities. Low-to-moderate intensities that prevail most of the time generally ensure a slow turnover of plant parts or individual plants. High intensities, during outbreaks or as a result of management, can reduce the abundance of preferred species dramatically and alter vegetation structure and composition rapidly. On the other hand, D. Inouye (1982) and Paige and Whitham (1987) demonstrated that herbivory can increase seed production.

Overgrazing by domestic livestock has initiated the desertification of arid grasslands (by reducing vegetation cover, causing soil desiccation) in many parts of the globe (e.g., Schlesinger et al. 1990). Herbivory by exotic insect species (but rarely native species) is capable of eliminating plant species that are unable to compensate (McClure 1991, Orwig et al. 2002).

Patterns of herbivory often explain the observed geographic or habitat distributions of plant species (Bishop 2002, Crawley 1983, 1989, Fine et al. 2004, Huntly 1991, Louda et al. 1990a, Schowalter and Lowman 1999). Herbivory has a variety of positive and negative effects on plant growth and fitness, even for a particular plant species (Inouye 1982, see above). Herbivory can prevent successful establishment or continued growth, especially during the vulnerable seedling stage (J. G. Bishop 2002, D. Clark and Clark 1985, P. Hulme 1994, Wisdom et al. 1989). Louda et al. (1990a) reported that patterns of herbivory on two species of goldenbushes, *Happlopappus* spp., explained the significant difference between the expected and observed distributions of these species across an environmental gradient from maritime to interior ecosystems in southern California (Fig. 12.8). Louda and Rodman (1996) found that chronic herbivory by insects was concentrated on bittercress, *Cardamine cordifolia*, growing in sunny habitats, which largely explained the observed restriction of this plant species to shaded habitats.

Fine et al. (2004) used reciprocal transplants of clay- and white sand-specialist forest plant species and herbivore exclosures in a lowland Amazonian site in Peru to evaluate the effect of herbivores on plant survival in each habitat type. They found that the clay specialists grew significantly faster than the white sand specialists on both soil types when protected from herbivores. However, when unprotected from herbivores, clay specialists dominated clay forests, and white sand specialists dominated white sand forests, demonstrating an important role of herbivores in plant distribution.

Herbivory on dominant plant species can promote the persistence of associated plant species. Sousa et al. (2003) found that predation by a scolytid beetle, *Coccotrypes rhizophorae*, on seedlings of the mangrove, *Rhizophora mangle*, prevented establishment of *R. mangle* in lightning-generated gaps, which permitted a shade-intolerant species, *Laguncularia racemosa*, to co-dominate the mangrove community on the Caribbean coast of Panama. McEvoy et al. (1991) documented changes in plant community structure that resulted from herbivore-induced mortality to the exotic ragwort, *Senecio jacobaeae*, in western Oregon. Ragwort standing crop declined from  $> 700 \text{ g m}^{-2}$  (representing 90% of



**FIG. 12.8** Herbivore effects on plant species distribution. A) Gradients in observed frequencies of two goldenbushes, *Happlopappus venetus* (yellow) and *H. squarrosus* (orange), from maritime to interior montane sites in San Diego County, California. B and C) Observed frequency accounting for herbivore effects (solid lines) compared to potential distribution in the absence of herbivory (dashed line), based on several measures of performance of control plants when insects were excluded. From Louda et al. (1990a).

total standing crop of vegetation) to  $0.25 \text{ g m}^{-2}$  over a 2 yr period following the release of the ragwort flea beetle, *Longitarsus jacobaeae*. Grasses responded rapidly to declining ragwort abundance, followed by forbs, resulting in a relatively constant vegetation standing crop over the eight yrs of measurement.

Belle-Isle and Kneeshaw (2007) compared effects of spruce budworm, *Choristoneura fumiferana*, outbreaks, clearcutting with protection of advance regeneration and soil, and precommercial thinning on boreal forest dynamics. They found that budworm-generated canopy openings had greater diversity of saplings and trees and larger perimeter/area ratios than did harvested openings, suggesting that the rate of stand recovery and influence by the surrounding forest should be greater in budworm-generated openings. Yorks et al. (2003) reported that eastern hemlock, *Tsuga canadensis*, mortality designed to simulate hemlock woolly adelgid, *Adelges tsugae*, infestation doubled the percentage cover of understorey plant species within three years.

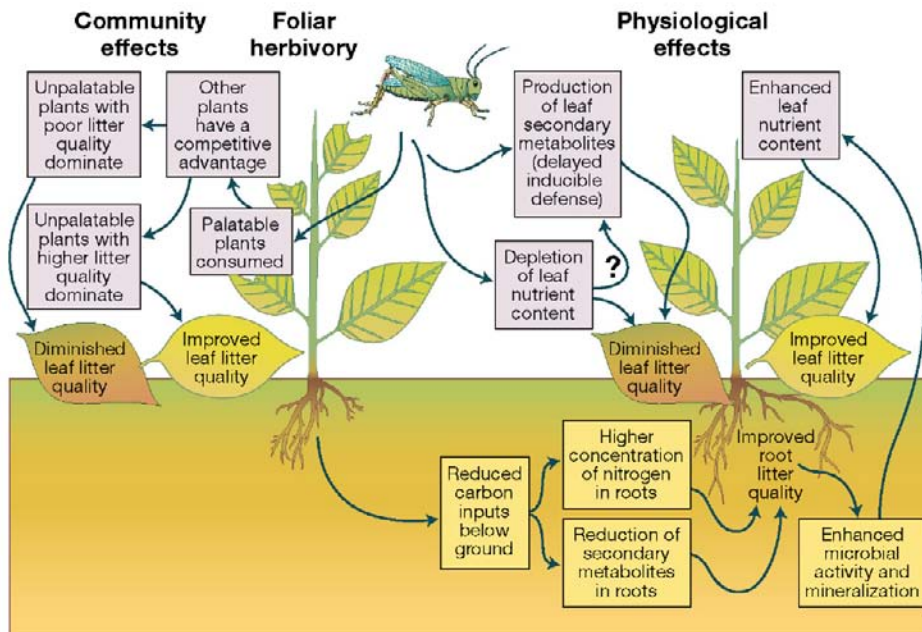
Herbivory often facilitates successional transitions (see Chapter 10). Selective herbivory among plant species suppresses those on which herbivory is focused and provides space and other resources to others, resulting in altered plant community composition (e.g.,

Davidson 1993, McEvoy et al. 1991, Schowalter 1981, Schowalter et al. 1986). V.K. Brown and Gange (1989), V.K. Brown et al. (1988) and D. Gibson et al. (1990) reported that chemically-reduced above-ground herbivory resulted in lower plant species richness after two years, whereas V.K. Brown and Gange (1989) found that reduced below-ground herbivory resulted in higher plant species richness, largely reflecting differential intensities of herbivory among various grass and forb species. V. Anderson and Briske (1995) simulated herbivory by livestock in a transplant garden containing mid-seral and late-seral grass species to test alternative hypotheses, that 1) mid-seral species have greater tolerance to herbivory or 2) herbivory is focused on late-seral species, to explain species replacement in intensively grazed grasslands in the southern U.S. They found that late-seral species had greater competitive ability, and equivalent or higher tolerance to herbivory, indicating that selective herbivory on the late-successional species is the primary mechanism for reversal of succession, i.e., return to dominance by mid-seral species under intense grazing pressure. Conversely, Bach (1990), Coley (1980, 1982, 1983), Coley and Aide (1991), and Lowman and Box (1983) reported that intensities of herbivory by insects were higher in earlier than in later successional stages. Schowalter et al. (1981a) suggested that the southern pine beetle is instrumental in advancing succession in the absence of fire, by selectively killing early successional pines, thereby favoring their replacement by later successional hardwoods (Fig. 10.6).

Davidson (1993) compiled data that indicated that herbivores may retard or reverse succession during early seres but advance succession during later seres. She suggested that herbivory is concentrated on the relatively less defended, but grazing tolerant, mid-successional grasses, forbs and pioneer trees (see Bach 1990). Environmental conditions may affect this trend. For example, succession from pioneer pine forest to late successional fir forest in western North America can be retarded or advanced, depending primarily on moisture availability and condition of the dominant vegetation. Under conditions of adequate moisture (riparian corridors and high elevations), mountain pine beetle advances succession by facilitating the replacement of host pines by the more shade-tolerant, fire-intolerant, understory firs. However, limited moisture and short fire return intervals at lower elevations favor pine dominance. In the absence of fire during drought periods, herbivory by several defoliators and bark beetles is concentrated on the understory firs, truncating (or reversing) succession. Fire fueled by fir mortality also leads to eventual regeneration of pine forest. Similarly, each plant species that became dominant during succession following Hurricane Hugo in Puerto Rico induced elevated herbivory that facilitated its demise and replacement (Torres 1992). The direction of succession then depends on which plant species are present and their responses to environmental conditions.

Changes in plant condition, community composition and structure affect habitat and food for other animals and microorganisms. Changes in nutritional quality or abundance of particular foliage, fruit or seed resources affect the abundances of animals that use those resources. Animals that require or prefer nesting cavities in dead trees may be promoted by tree mortality resulting from herbivore outbreaks.

Grazing on above-ground plant parts can affect litter and rhizosphere processes in a variety of ways (Bardgett et al. 1998). Reduced foliar quality resulting from induced defenses or replacement of palatable by less palatable plant species can reduce the quality of detrital material (Fig. 12.9). Seastedt et al. (1988) reported that simulation of herbivore effects on throughfall (precipitation enriched with nutrients while passing over foliage) affected litter arthropod communities. Schowalter and Sabin (1991) found that three taxa of litter arthropods were significantly more abundant under experimentally defoliated

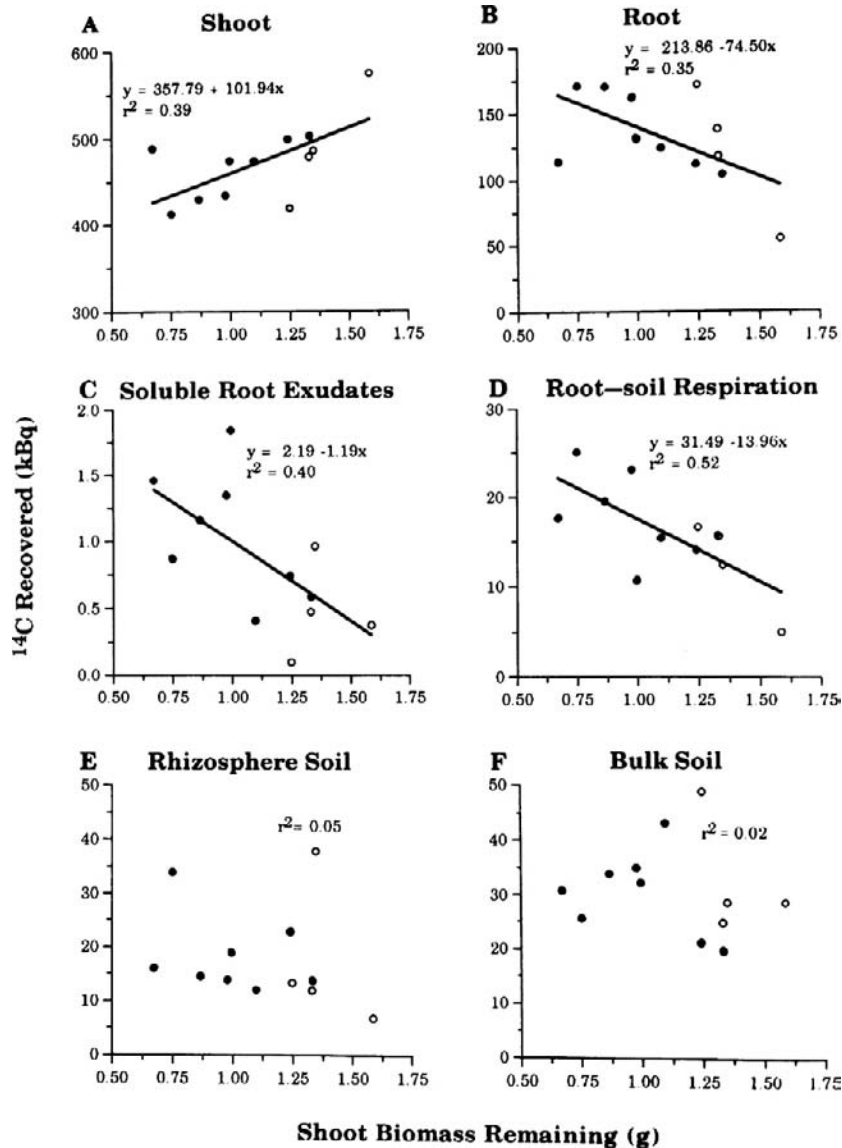


**FIG. 12.9** Effects of herbivory on host nutrient allocation and trophic interactions. Reprinted from, Bardgett et al. (1998), with permission from Elsevier.

( $\leq 20\%$  foliage eaten) Douglas-fir saplings, compared to non-defoliated saplings. B. Reynolds et al. (2003) experimentally evaluated effects of herbivore-derived litter components on litter invertebrates. They found that addition of herbivore feces increased abundances of Collembola and fungal- and bacterial-feeding nematodes; addition of throughfall increased abundances of fungal- and bacterial-feeding nematodes; litterfall exclusion reduced abundances of oribatid and prostigmatid mites. Altered carbon storage in roots (Filip et al. 1995, Holland et al. 1996) affects resources that are available for below-ground food webs (Fig. 12.10). Bardgett et al. (1997, 1998) reported that microbial biomass, nematode abundance and soil respiration rates were consistently reduced by removal of sheep grazing (Fig. 12.11). Gehring and Whitham (1991, 1995) documented a significant reduction in mycorrhizal activity on roots of piñon pines subject to defoliation by insects, compared to non-defoliated pines.

Insect herbivores or their products constitute highly nutritious resources for insectivores and other organisms. Caterpillars concentrate essential nutrients by several orders of magnitude over concentrations in foliage tissues (e.g., Schowalter and Crossley 1983). Abundances of insectivorous birds and mammals often increase in patches that are experiencing insect herbivore outbreaks (Barbosa and Wagner 1989, Koenig and Liebhold 2005). Arthropod tissues also represent concentrations of nutrients for decomposers (Schowalter and Crossley 1983, Seastedt and Tate 1981).

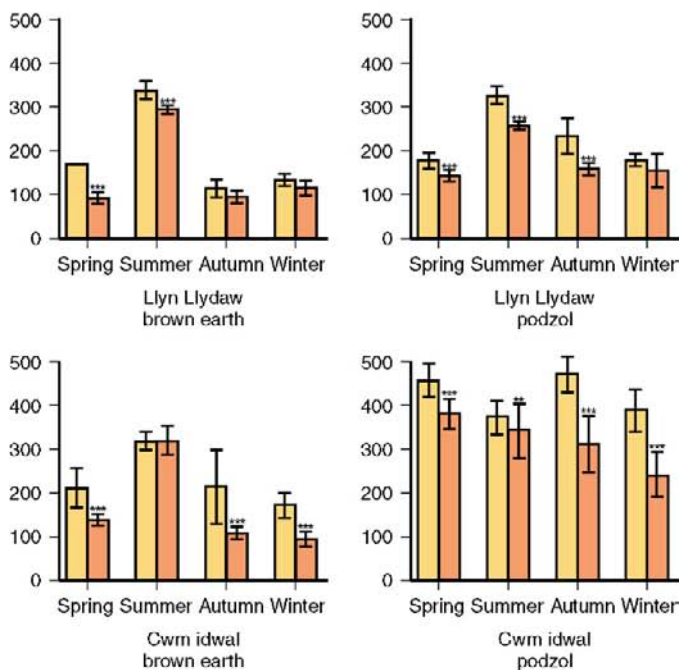
A variety of organisms utilize honeydew accumulation from aphids, scales and other plant-feeding Hemiptera. Ants, honey bees, *Apis mellifera*, hummingbirds, and other animals forage on the carbohydrate-rich honeydew (E. Edwards 1982). Stadler and Müller (1996) and Stadler et al. (1998) reported that the presence of honeydew significantly



**FIG. 12.10** Carbon allocation as a function of intensity of herbivory (measured as shoot biomass remaining) in A) shoots, B) roots, C) soluble root exudates, D) respiration from roots and soil, E) rhizosphere soil, and F) bulk soil. Data were normalized for differences in  $^{14}\text{CO}_2$  uptake; 1 kBq = 1000 disintegrations  $\text{sec}^{-1}$ . Shoot biomass was inversely related to leaf area removed by herbivores. Regression lines are shown where significant at  $P < 0.05$ . Open circles represent ungrazed plants, solid circles grazed plants. From Holland et al. (1996) with kind permission of the authors and Springer Science + Business Media.

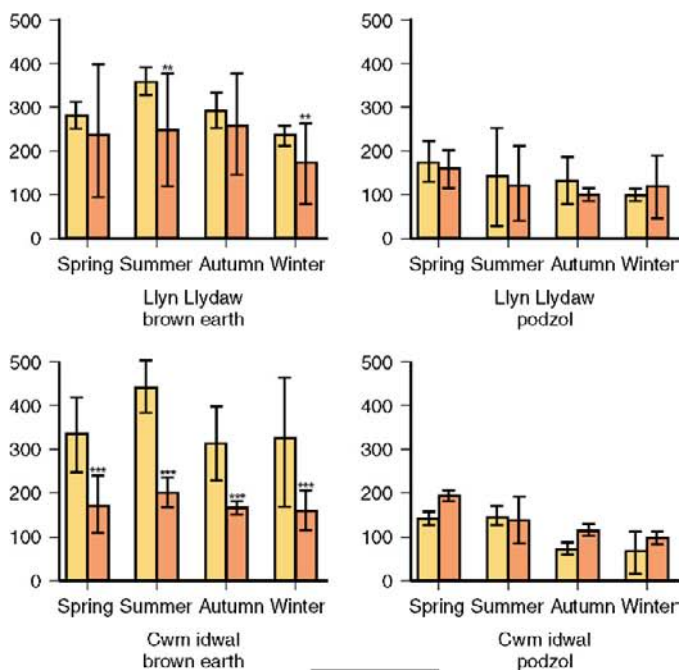


MICROBIAL BIOMASS  
(gCm<sup>-2</sup>)



A

NEMATODES  
(m<sup>-2</sup> x 10<sup>4</sup>)



B



increased the growth of a variety of epiphytic bacteria, yeasts and filamentous fungi on the surface of conifer needles, potentially affecting photosynthetic efficiency of underlying foliage.

### C. Water and Nutrient Fluxes

Relatively few studies have addressed effects of insect herbivores on biogeochemical cycling processes, despite herbivore effects on plant chemistry and the importance of vegetation and litter structure, and turnover of material between these pools, to biogeochemical cycling. Crossley and Howden (1961) pioneered the study of nutrient fluxes from vegetation through arthropod communities, and demonstrated that insect herbivores concentrate and accelerate cycling of some nutrients. Subsequent research has demonstrated that insect herbivores affect biogeochemical cycling in a number of ways, including altered vegetation composition and structure, direct transfer of material from plants to litter, and effects on litter quality and litter communities.

Nutrient fluxes are affected in part by the effects of herbivores on nutrient uptake and allocation patterns within plants. Frost and Hunter (2008a) used stable isotopes ( $^{13}\text{C}$  and  $^{15}\text{N}$ ) to explore effects of the white-marked tussock moth, *Orgyia leucostigma*, on red oak seedlings. They found that herbivory reduced carbon allocation to fine roots by 63%, with a corresponding increase in new carbon allocation to shoots, and reduced nitrogen allocation to fine roots by 39%, with increased storage in taproot and stem tissues. Recovery of  $^{13}\text{C}$  in soil pools was similar between treatments, indicating that exudation of carbon remains an actively regulated process. Changes in nutrient concentrations among plant tissues affect their rate of turnover. Crutsinger et al. (2008) reported that galled goldenrod, *Solidago altissima*, had lower litter mass and N mineralization than did ungalled plants. Schweitzer et al. (2005) also found that gall aphids, *Pemphigus betae*, reduced litter quality of *Populus* spp., and galled litter decomposed 34–40% slower than non-galled litter.

Altered vegetation structure or composition changes patterns of acquisition and turnover of various nutrients by the vegetation. For example, Kurz et al. (2008) found that widespread pine mortality during outbreaks of mountain pine beetle reduced carbon uptake and increased carbon emission from decaying trees. K. Clark et al. (2010) found similar results for defoliation by the gypsy moth, *Lymantria dispar*. In both studies, the change in net carbon flux converted the forest from a carbon sink to a carbon source. However, M. Brown et al. (2010) noted that forests that were recovering from mortality to mountain pine beetle continued to be growing-season carbon sinks, as a result of increased photosynthesis by remaining healthy trees and understory vegetation, whereas nearby harvested stands remained carbon sources ten years after harvest. Ritchie et al. (1998) reported that herbivory generally reduced the abundance of plant species with N-rich tissues, leading to replacement by plant species with lower N concentrations, in an oak savanna in the north central U.S. Similarly, insects (such as bark beetles) that affect the relative composition of Douglas-fir and western redcedar, *Thuja plicata*, in the northwestern U.S. also affect calcium dynamics and soil pH, i.e.,

**FIG. 12.11** Seasonal variation in microbial biomass and nematode abundance in grazed and ungrazed plots of two grassland types in Ireland. Vertical lines represent standard errors; \* =  $P < 0.05$ , \*\* =  $P < 0.01$ , \*\*\* =  $P < 0.001$ . Reprinted from, Bardgett et al. (1997), with permission from Elsevier.

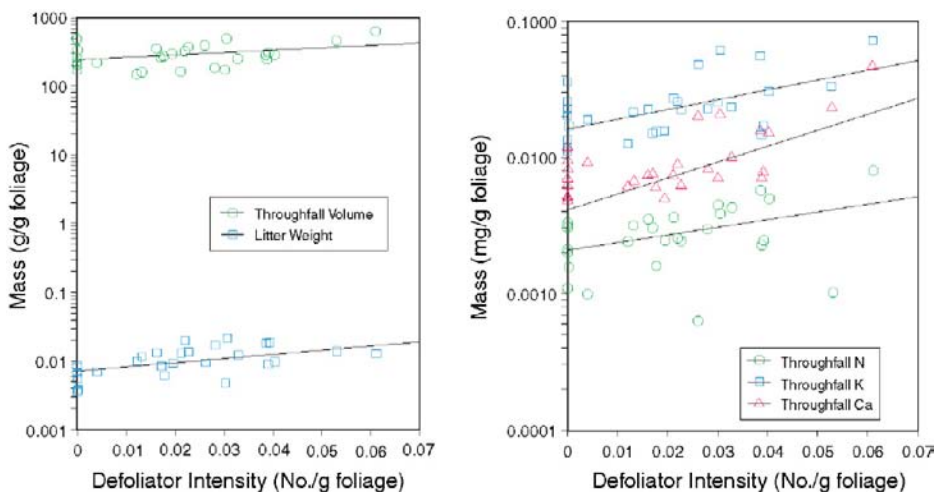
calcium accumulation and higher pH are found under western redcedar compared to Douglas-fir (e.g., Kiilsgaard et al. 1987).

Reduced metabolic demands by pruned, defoliated or killed plants reduces their water and nutrient uptake (Ford and Vose 2007, W. Webb 1978), and potentially contributes to plant survival during drought periods (Kolb et al. 1999). Ford and Vose (2007) estimated that the mortality of eastern hemlock to hemlock woolly adelgid would decrease annual transpiration by 10% and winter–spring transpiration by 30%, leading to increased stream-water discharge. W. Webb and Karchesy (1977) reported that defoliation by the Douglas-fir tussock moth reduced host starch content proportional to the intensity of defoliation. Reallocation of carbon by plants, as a result of herbivory, alters carbon cycling and energy flux.

Herbivory affects biogeochemical cycling directly, by changing the timing, amount, and form of nutrients that are transferred from plants to litter or soil. In the absence of herbivory, litter accumulation may be highly seasonal (i.e., concentrated at the onset of cold or dry conditions) and have low nutrient concentrations, especially of nitrogen or other nutrients that are resorbed from senescing foliage (Gutschick 1999, Marschner 1995). Herbivory generally increases the amount and nutrient content of litter inputs during the growing season, by transferring nutrients in fragmented plant material, insect tissues, and insect feces (Fonte and Schowalter 2005, Hollinger et al. 1986, le Mellec et al. 2009, Schowalter et al. 1991, Stadler et al. 2006).

Insect tissues and feces have higher concentrations of nutrients, especially N, that control litter decomposition than does senescent leaf litter (Effler et al. 2006, Frost and Hunter 2004, 2007, 2008b, M.D. Hunter et al. 2003, Schowalter and Crossley 1983). Hollinger (1986) reported that during an outbreak of the California oak moth, *Phryganidia californica*, fluxes of nitrogen and phosphorus from trees to the ground more than doubled, and feces and insect remains accounted for 60–70% of the total nitrogen and phosphorus fluxes. J.R. Grace (1986) found a similar increase in nitrogen flux, from 31 kg N ha<sup>-1</sup> in non-defoliated forest to 52 kg N ha<sup>-1</sup> in forest that had been defoliated by gypsy moth in Pennsylvania, U.S. Folivory also increases the flux of nutrients in the form of through-fall (precipitation enriched with nutrients as it percolates through the canopy). Through-fall nutrient fluxes that flow from the canopy to the litter are controlled strongly by foliage area, exposed surfaces resulting from herbivory, and amount of precipitation (Lovett et al. 1996). M.D. Hunter et al. (2003), Kimmins (1972), Schowalter et al. (1991), Seastedt et al. (1983), and Stachurski and Zimka (1984) have shown that herbivory greatly increases the leaching of nutrients from chewed foliage (Fig. 12.12). Stadler et al. (2006) added that hemlock woolly adelgid, *Adelges tsugae*, infestation increased dissolved organic carbon by 25%, dissolved organic nitrogen by 29% and potassium by 39%, but decreased dissolved inorganic nitrogen by 40%, in throughfall from eastern hemlock, *Tsuga canadensis*, compared to uninfested trees. However, in ecosystems with high annual precipitation, herbivore-induced nutrient turnover may be masked by nutrient inputs via precipitation (Schowalter et al. 1991).

The contribution of honeydew to nutrient cycling has been a subject of considerable interest. Stadler and Müller (1996) and Stadler et al. (1998) documented significant amounts of dissolved organic carbon in aphid honeydew. Most of the honeydew in their studies was immobilized quickly by phylloplane microorganisms before reaching the ground. Owen (1978) and Owen and Wiegert (1976) suggested that the trisaccharide, melezitose, in aphid honeydew provides a rich, labile carbohydrate resource for free-living, nitrogen-fixing soil bacteria. Petelle (1980) subsequently demonstrated that fructose, also abundant in aphid honeydew, increased nitrogen fixation 9 times more than



**FIG. 12.12** Folivore effects on throughfall, litterfall and fluxes of N, K and Ca from young Douglas-fir during the feeding period, April–June, in western Oregon. Reprinted from, Schowalter et al. (1991), with permission from Elsevier.

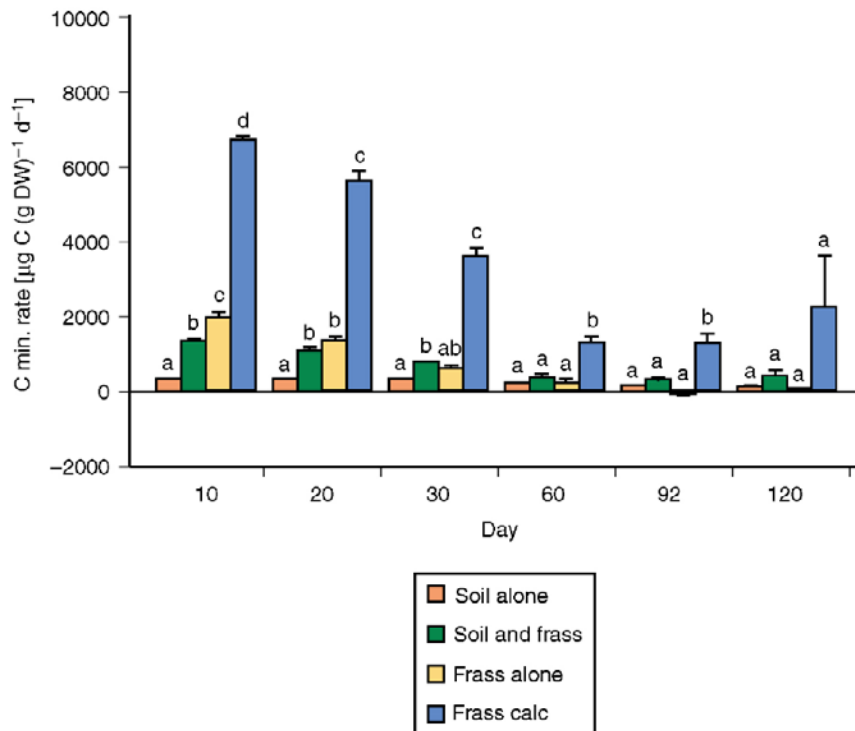
did melezitose. However, Grier and Vogt (1990) found that chemical removal of aphids increased available soil nitrogen, nitrogen mineralization rates, net primary production and nitrogen uptake by red alder, *Alnus rubra*. These data, together with those of Lovett and Ruesink (1995) and Stadler et al. (2001), indicate that nutrients mobilized by folivores and sap-suckers may be immobilized rapidly by soil microorganisms.

Several studies have experimentally addressed the effect of herbivore-derived inputs on decomposition, soil nutrient fluxes, and nutrient uptake by plants. Throughfall, senescent foliage, fresh foliage fragments lost via herbivory (greenfall), and herbivore feces differ in the amount and form of nitrogen and carbon compounds they contain, as well as in the degree of microbial pre-conditioning. Fonte and Schowalter (2004) demonstrated that fresh foliage of four tropical tree species in Puerto Rico had higher nitrogen concentration and decomposed significantly more rapidly than did senescent foliage from the same tree species. Zlotin and Khodashova (1980) reported that herbivore feces decomposed more rapidly than did raw plant material. M.D. Hunter et al. (2003) found that deposition of folivore feces explained 62% of the variation in soil nitrate availability.

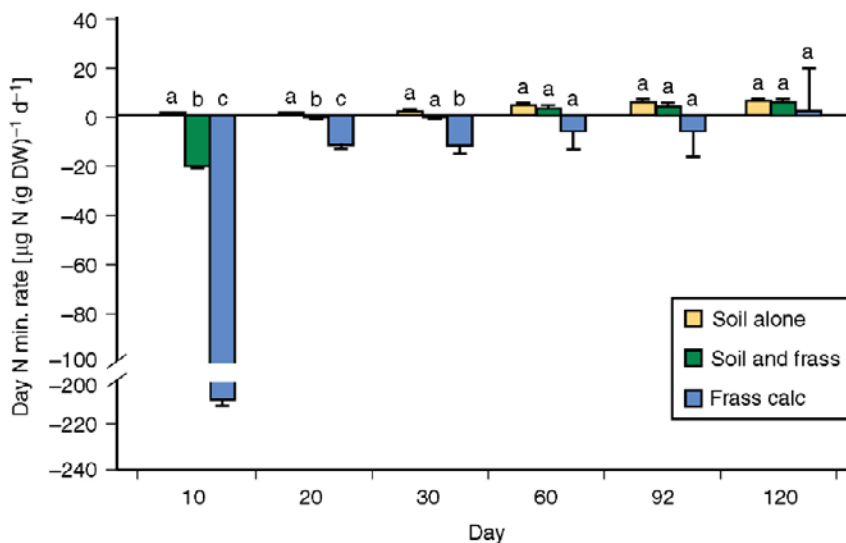
However, changes in nutrient content and defenses induced by herbivory affect the quality of litter for decomposers in complex ways (e.g., S. Chapman et al. 2003, 2006, Coley and Barone 1996, M.D. Hunter et al. 2003, Kurokawa and Nakashizuka 2008, le Mellec et al. 2009). S. Chapman et al. (2006) proposed that herbivory on evergreen trees commonly results in premature leaf abscission, higher litter quality and accelerated decomposition, whereas herbivory on deciduous trees is more likely to result in production of induced defenses and decelerated decomposition. Although induced defenses may inhibit decomposition (R. Stout 1989), rapid leaching in wet ecosystems may minimize their effect on decomposition (Ardón and Pringle 2008). As noted above, Schweitzer et al. (2005) found that herbivory reduced the decomposition rate of litter. The amount of nitrogen flux relative to background levels also may determine the direction of herbivore effect on decomposition. Treseder (2008) conducted a meta-analysis of nitrogen subsidy studies and found that increased nitrogen flux does not necessarily increase decomposition rate.

Results depend on the responses of soil microbes to increased nitrogen supply. Microbial activity may increase in response to nitrogen subsidy when background levels of nitrogen are low, but decrease in response to subsidy when background levels are high.

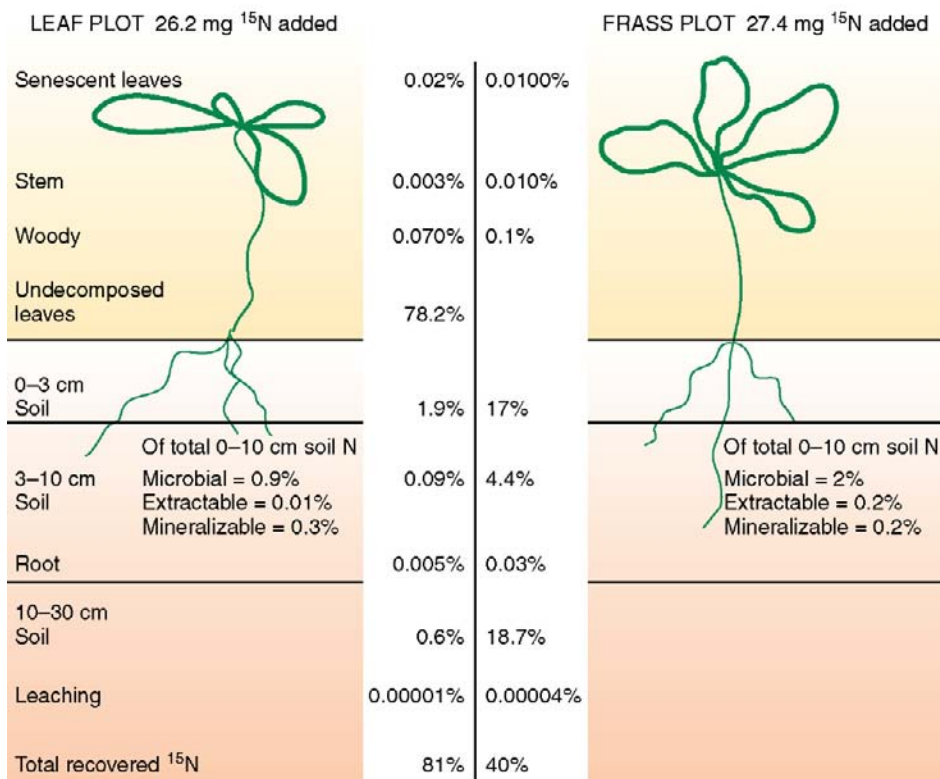
Lovett and Ruesink (1995) reported that gypsy moth feces contained much labile carbon and nitrogen but that microbial growth, stimulated by labile carbon (Fig. 12.13), was sufficient to immobilize all the available nitrogen (Fig. 12.14). In a subsequent experiment, Christenson et al. (2002) added  $^{15}\text{N}$ -labeled leaf litter or gypsy moth feces to experimental plots, in which a red oak seedling had been planted, to evaluate pathways of nitrogen flux (Fig. 12.15). They found that gypsy moth feces significantly increased the concentration of  $^{15}\text{N}$  in total and mineralizable nitrogen pools in surface and subsurface soils, with 40% of the recovered  $^{15}\text{N}$  incorporated in soil. The red oak seedlings in plots with feces addition had significantly higher  $^{15}\text{N}$  concentrations in green leaves, stems and roots. By comparison, 80% of the  $^{15}\text{N}$  in plots with added leaf litter remained in undecomposed leaves. Differences in the amounts of  $^{15}\text{N}$  recovered between the two treatments might reflect unmeasured gas fluxes or leaching of dissolved organic nitrogen. Alternatively, increased C/N ratio in frass (le Mellec et al. 2009) may stimulate microbial immobilization of nitrogen. Frost and Hunter (2007) demonstrated, using  $^{15}\text{N}$ , that herbivore feces are



**FIG. 12.13** Mean carbon mineralization rate ( $\text{CO}_2$  evolution) in soil alone, soil + gypsy moth frass, frass alone, and frass in soil + frass (calculated by subtracting mean net C mineralization in soil alone from that in the soil + frass and expressing the rate per gram dry weight of frass). Vertical lines are standard errors. Within a sample date, bars under the same letter are not significant at  $P < 0.05$ . From Lovett and Ruesink (1995) with kind permission of Springer Science + Business Media.



**FIG. 12.14** Mean potential net nitrogen mineralization rate (extractable  $\text{NH}_4^+ + \text{NO}_3^-$ ) in soil alone, soil + gypsy moth frass, frass alone, and frass in soil + frass (see Fig. 12.13 for calculation of frass contribution). From Lovett and Ruesink (1995) with kind permission from Springer-Verlag + Business Media.



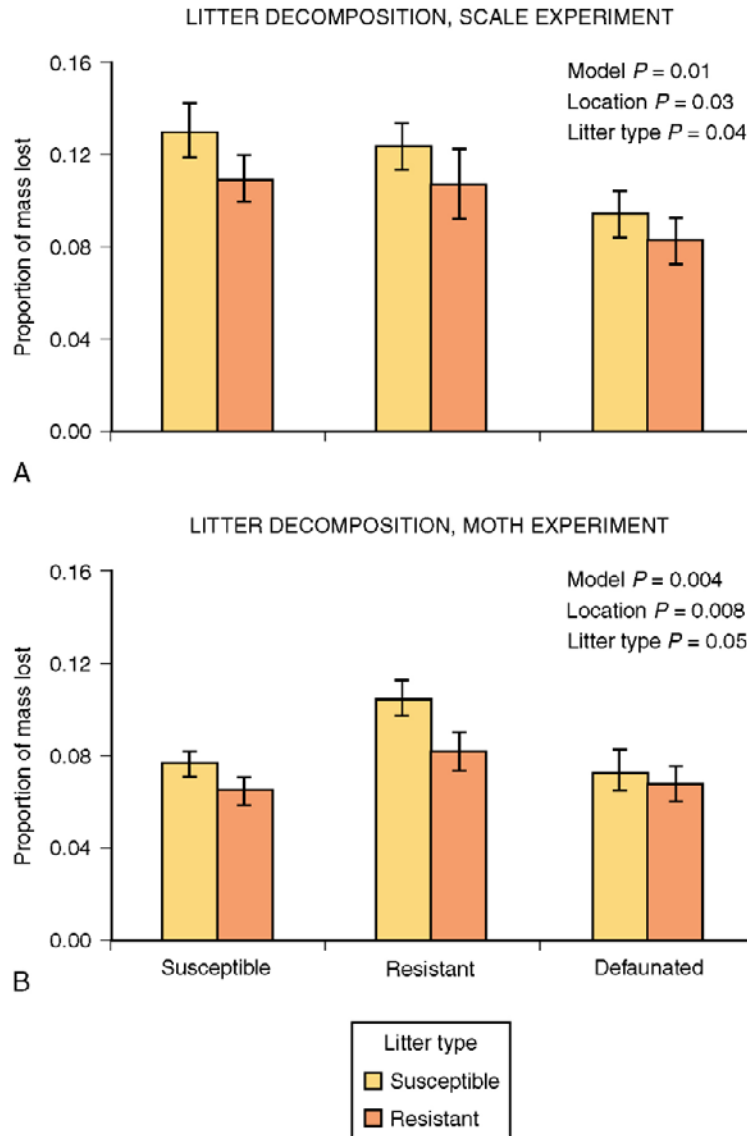
**FIG. 12.15** Percent recovery of  $^{15}\text{N}$  from various fractions, relative to the total amount added to plots as insect feces in June or as leaves at the time of leaf senescence in November. From Christenson et al. (2002) with permission from Elsevier.

rapidly decomposed, and some of the feces-N became available for plant uptake, and even incorporation into subsequent defoliators.

Belovsky and Slade (2000) reported that grasshoppers, *Melanoplus sanguinipes*, accelerated nitrogen cycling by increasing the abundance and decomposition rate of grass litter. Increased grasshopper density increased plant productivity up to 18%, especially by plants that are better competitors when nitrogen is more available, but high grasshopper densities depressed primary productivity. Cobb et al. (2006) found that hemlock woolly adelgid significantly increased the decomposition rate of hemlock litter in infested stands, compared to uninfested stands, largely as a result of increased soil moisture in infested stands. However, Stadler et al. (2006) found that adelgids increased foliar N, compared to uninfested foliage, which probably affected decomposition rate.

S. Chapman et al. (2003) used a unique long-term herbivore exclusion experiment in Arizona, U.S., to evaluate the effects of folivores and sap-suckers on foliage chemistry and decomposition. The shoot moth, *Dioryctria albovittella*, feeds on the shoots and cones of mature piñon pines, *Pinus edulis*, whereas the scale insect, *Matsucoccus acalyptus*, feeds only on needles of juvenile trees. Exclusion of both herbivores from experimental trees permitted comparison of susceptible, infested and uninfested, and resistant trees. Foliage litter chemistry was similar for resistant and susceptible uninfested trees, but both had significantly lower nitrogen concentrations than did the foliage litter of susceptible infested trees for both insect species, demonstrating that the insects were responsible for the increased nitrogen in litter. Furthermore, phosphorus concentration was significantly higher (by 50%) in litter from trees that were infested with scale insects, compared to resistant and susceptible uninfested trees. The scale insect, but not the moth, significantly increased the rate of litterfall from infested trees, relative to resistant and susceptible uninfested trees. Litter from resistant and susceptible infested trees was placed under each treatment type (Fig. 12.16). As expected, litter from susceptible, infested trees for both insects decomposed significantly more rapidly than did litter from resistant trees. For the scale insect treatments, both resistant and susceptible litter decomposed more rapidly under resistant and susceptible infested trees, compared to susceptible uninfested trees, perhaps because of higher throughfall, soil moisture and soil temperature that were indirect effects of herbivory by scales. Litter from infested trees decomposed more rapidly under infested trees than did resistant litter under resistant trees. For moth treatments, both litter types decomposed more rapidly under resistant trees than under susceptible infested or uninfested trees; litter from infested trees did not decompose more rapidly under infested trees than did resistant litter under resistant trees, for unknown reasons. However, because litter from moth-infested trees was of higher quality and decomposed more rapidly across all treatments, compared to resistant litter, higher rates of decomposition might be observed over longer time periods. Classen et al. (2007a, b) subsequently found that differences in decomposition and mineralization of litter from susceptible and resistant trees reflected increased litter N and increased soil moisture resulting from herbivory, as mediated by seasonal changes in soil/litter microbial abundance and activity. Madritch et al. (2007) found similar results for decomposition of litter from aspen, *Populus tremuloides*, genotypes vs. gypsy moth and forest tent caterpillar, *Malacosoma disstria*, frass.

The shift in biomass dominance from folivores to sap-suckers following disturbance in temperate and tropical forests (Schowalter 1995, Schowalter and Ganio 1999, Schowalter et al. 1981c) indicates an accompanying shift in the predominant flux of nutrients. Dominance by folivores in undisturbed forests should transfer nutrients primarily as throughfall (enhanced by leaching from chewed foliage) and fragmented plant parts, whereas



**FIG. 12.16** Increased decomposition resulting from herbivore-induced changes in litter quality. Litter from susceptible or resistant piñon pines was placed under susceptible, resistant or experimentally defaunated trees.  $N=20$  for all treatments; vertical lines are standard errors. P values are given for main effects by 2-way ANOVA. The two litter types did not differ within any location, but did differ across all three locations. From S. Chapman et al. (2003) with permission from the Ecological Society of America.

dominance by sap-suckers in early successional communities should transfer nutrients predominantly as a labile carbohydrate solution that stimulates microbial growth and immobilization of accompanying nutrients. Holland (1995) reported that soil microbial biomass peaked at intermediate levels of herbivory in no-tillage agricultural systems, perhaps because moderate intensities of herbivory increased the root exudates that fuel microbial production (Fig. 12.9) (Holland et al. 1996).



Herbivory also mediates fluxes of nutrients among plants. Carbon and nitrogen exuded from roots to support mycorrhizal and soil microbial activity often become available to neighboring plants. E. Ayres et al. (2007) used  $^{15}\text{N}$  to demonstrate that herbivory by above-ground (but not below-ground) herbivores increased below-ground flux of N from white clover, *Trifolium repens*, to perennial ryegrass, *Lolium perenne*, 5-fold in laboratory microcosms. Growth of *L. perenne* was not affected in any of the treatments. However, given that primary production in terrestrial ecosystems is frequently N-limited, they suggested that such transfer of below-ground N among plants could alter competitive interactions and plant community structure.

Herbivory has the capacity to alter nutrient cycling processes at the landscape or watershed level. Although most studies have addressed herbivore effects during outbreaks, non-outbreak levels of herbivory can significantly affect fluxes (M.D. Hunter et al. 2003). MacDonald et al. (1992) attributed elevated nitrate concentrations in soil solution in hardwood forests in Michigan, U.S., to defoliation by the forest tent caterpillar. Swank et al. (1981) reported that defoliation of hardwood forests by the fall cankerworm, *Alsophila pomataria*, in the southern Appalachian Mountains in North Carolina, U.S., increased nitrate export via soil leaching and streamflow. Eshleman et al. (1998) and J. Webb et al. (1995) documented increased nitrate export in streams draining hardwood forests defoliated by the gypsy moth in the mid-Appalachian Mountains in Pennsylvania, Virginia and West Virginia. However, Bormann and Likens (1979) reported no increase in nitrate export resulting from saddled prominent caterpillar, *Heterocampa guttivitta*, in the northern Appalachian Mountains in New Hampshire. Differences in results between these studies might reflect elevated nitrogen inputs throughout the northern Appalachians during the 1970s or different retention mechanisms among northern and southern study sites (e.g., Treseder 2008). Although most of the nitrogen consumed by folivores is retained by the ecosystem (Lovett and Ruesink 1995, Frost and Hunter 2007, 2008b), even small increases in stream export of nitrate can alter water quality and leaching of nutrient cations such as Ca or toxic cations such as Al (Lovett et al. 2002).

## D. Effects on Climate and Disturbance Regime

Herbivore-induced changes in vegetation structure probably affect soil temperature, relative humidity, erosion, soil moisture and soil fertility (see Chapter 11). Reduced foliage surface area reduces the interception of precipitation and evapotranspiration (G. Parker 1983). Changes in litter accumulation can affect ecosystem vulnerability or sensitivity to some disturbances, especially fire. However, relatively few studies have demonstrated herbivore effects on these variables.

Herbivory increases vegetation porosity (Fig. 12.17) and the penetration of light, precipitation, and wind to the understory and soil surface. Canopy opening greatly affects abiotic conditions in the understory (Chazdon and Fetcher 1984, Denslow 1995, Fernandez and Fetcher 1991). Increased soil warming due to penetration of sunlight may be offset to some extent by increased penetration of precipitation to the ground. Schowalter et al. (1991) reported that a 20% loss of Douglas-fir foliage by a folivore, *Lophocampa argentata*, doubled the amount of water reaching the soil surface. Classen et al. (2005) reported that herbivory by scale insects increased soil moisture 35% at the primary rooting depth of 15–30 cm and increased maximum soil temperature by an average 5°C at 5 cm depth under piñon pines with scale insects, compared to resistant trees or trees with scales removed (Fig. 12.18). Classen et al. (2007a) concluded that the mechanism by which

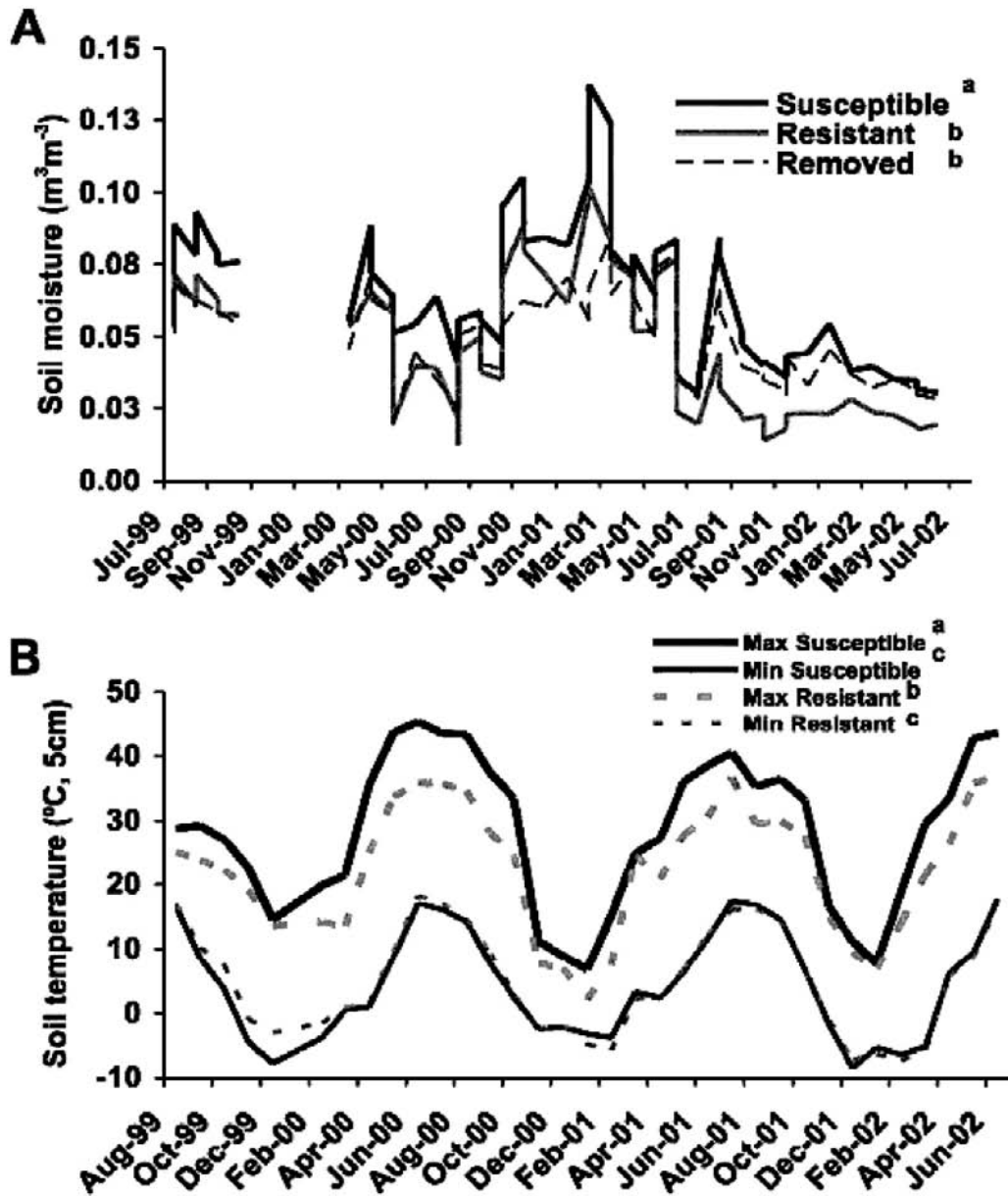


**FIG. 12.17** Increased canopy porosity resulting from herbivory. Holes chewed by folivorous insects in the large leaves of *Cecropia* reduce interception of light, water and airflow by the canopy and increase penetration to lower strata and the forest floor.

herbivory affected litter mass loss and nutrient dynamics in this woodland system was through change in canopy cover and consequent change in litter microclimate. Increased accumulation of litter resulting from herbivory in forest ecosystems may contribute to soil water retention.

Canopy opening over large areas by herbivores could affect regional climate. Although most studies of effects of canopy opening on climate have focused on anthropogenic canopy removal (see Chapter 11), herbivory may have similar effects, e.g., increased soil surface temperature, reduced evapotranspiration, and consequent regional warming and drying (J. Foley et al. 2003a, Salati 1987).

Herbivory can increase or decrease the likelihood or severity of future disturbances. Herbivory in grasslands reduces the amount of standing dead material (Knapp and Seastedt 1986), thus potentially reducing the severity of fire but increasing soil exposure to desiccation and exacerbating the effects of drought. However, reduced foliage surface area may reduce water demand and mitigate the effects of drought (Kolb et al. 1999). Herbivory in forests increases fuel accumulation in the form of fine and coarse litter material, thereby increasing the likelihood and severity of fire, especially in arid forests where litter decomposes slowly and lightning strikes are frequent (McCullough et al. 1998, Schowalter 1985). Bebi et al. (2003) concluded that spruce, *Picea engelmannii*, mortality to spruce beetle, *Dendroctonus rufipennis*, in Colorado, U.S., did not increase the occurrence of subsequent fires. Péch (1993) found similar results for balsam fir, *Abies balsamea*,



**FIG. 12.18** Effect of herbivory by scale insects, *Matsucoccus acalyptus*, on soil moisture (A) and temperature (B) in a piñon-juniper woodland in northern Arizona during Aug 1999–Jun 2002. Treatments included trees that were susceptible or resistant to the scale or susceptible but with scales removed. Different letters indicate significant differences, using contrasts. From Classen et al. (2005) with permission from the Soil Science Society of America.

mortality to the spruce budworm, *C. fumiferana*, in eastern Canada. The absence of subsequent fire in these cases may have reflected the rapid decomposition of spruce and fir litter (Bebi et al. 2003, Péché 1993). Alternatively, outbreaks that increase the amount and distribution of fine litter materials may increase the probability of low intensity fire

and reduce the probability of catastrophic fire. Outbreaks that result in tree mortality and increased abundance of ladder fuels may contribute to catastrophic fire. Jenkins et al. (2008) concluded that the effect of bark beetles on fire is complex. Fuel accumulation alone had less effect on fire than did changes in stand structure. Although we might expect tree mortality to increase the likelihood of catastrophic crown fire, the decreased continuity of crown fuels could slow fire spread through the canopy, but increased wind penetration could speed fire spread in the more open understory.

As with fire, few experimental studies have addressed effects of insect outbreaks on storm disturbance. Vegetation structure, especially height, density and “roughness”, affects wind speed (Gardiner et al. 2005). Vertical height and density determine the degree to which vegetation impedes near-surface winds. Greater height (especially of woody vegetation) and density confer greater wind resistance. Insect outbreaks that open the canopy should increase penetration of high wind speeds and the probability of treefall, but also should reduce the wind resistance of defoliated trees. J. R. Moore and Maguire (2005) found that pruning at least 80% of the canopy was necessary to reduce wind stress significantly. However, trees with greater exposure to wind typically have greater root development and wind-firmness (Tamasi et al. 2005). Taylor and MacLean (2009) reported that wind-related tree mortality following spruce budworm defoliation in eastern Canada was related to the severity of the outbreak. Tree mortality during storms peaked 11–15 years after outbreak, due to greater exposure of surviving trees to wind.

### III. SUMMARY

Herbivory, the feeding on living plant parts by animals, is a key ecosystem process that has widely recognized effects on primary production and on vegetation structure and composition. The effect of herbivory depends on herbivore feeding type and intensity. Different types of herbivory affect different tissues and the production, translocation and accumulation of photosynthates to varying degrees.

A number of methods have been used to measure the intensity and effects of herbivory. The most common method for measuring intensity has been estimation of consumption rates by individual herbivores and extrapolation to population size. This method can be used to measure consumption by sap-sucking herbivores as well as folivores. A second method is measurement, by various means, of missing plant biomass. This method does not account for completely consumed (and unobserved) parts or for compensatory growth. Measurement of turnover of marked plant parts is the most accurate, but labor-intensive, method for estimating herbivory. Estimates of herbivory can differ by 2-5 times among methods, making standardization a key for comparison among ecosystems. Evaluating the effect of herbivory requires measurement of a variety of plant and ecosystem responses, not simply plant growth or productivity.

The intensity of herbivory varies widely, but a trend is apparent among ecosystem types. Herbivory generally is lowest (< 2% reduction in primary production) in some forests and highest (most primary production consumed daily) in aquatic ecosystems. Insects are the primary herbivores in forest ecosystems and may account for the bulk of herbivory in grasslands, even though vertebrate grazers are more conspicuous.

Herbivory has well-known effects on the survival, productivity and growth form of individual plants. However, the traditional view of herbivory as a negative effect on plants is being replaced by a view that recognizes the more complex effects of variable intensity and timing. Moderate intensities of herbivory often stimulate production, through

compensatory growth, and flowering, thereby increasing fitness. A given intensity of herbivory can have different effects at different times during the growing season or under different environmental conditions. Herbivory can affect the growth form of plants by terminating shoot growth and initiating branching and by affecting shoot-to-root ratios. Changes in survival, productivity and growth of individual plant species affect vegetation structure and community dynamics. Herbivores often determine the geographic or habitat patterns of occurrence of plant species and facilitate successional transitions.

An increasing number of studies have addressed the effects of insect herbivores on biogeochemical cycling or other abiotic conditions. Herbivores affect, often dramatically, the turnover of plant nutrients to litter as plant fragments, feces and animal tissues and nutrients leached from chewed surfaces. Folivory alters the seasonal patterns of nutrient fluxes by transferring material prior to plant resorption of nutrients from senescing parts. Sap-sucking insects transfer copious amounts of labile carbohydrates (as honeydew) that stimulate growth and nutrient uptake by microbes. Herbivory also can affect climate and the likelihood and intensity of future disturbances. Reducing vegetation cover greatly affects the penetration of light, precipitation and wind to the understory and soil, affecting soil warming and water content, relative humidity, erosion, transpiration, etc. Reduced vegetation biomass or litter accumulation affects the abundance of fuel to support fire and affects soil water-holding capacity and vegetation demand for water during drought. Therefore, herbivory can influence the stability of an ecosystem substantially (Chapter 15).

# Pollination, Seed Predation and Seed Dispersal

## I. Types and Patterns of Pollination

- A. *Pollinator Functional Groups*
- B. *Measurement of Pollination*
- C. *Spatial and Temporal Patterns of Pollination*

## II. Effects of Pollination

## III. Types and Patterns of Seed Predation and Dispersal

- A. *Seed Predator and Disperser Functional Groups*
- B. *Measurement of Seed Predation and Dispersal*
- C. *Spatial and Temporal Patterns of Seed Predation and Dispersal*

## IV. Effects of Seed Predation and Dispersal

## V. Summary

### Consequences of pollinator decline

Pollination is among the most visible and important ecosystem services and is necessary for reproduction of 60–70% of all plant species and 35% of global crop production (A. Klein et al. 2007, Kremen et al. 2007, Losey and Vaughan 2006). Pollination of agricultural crops by honey bees, *Apis mellifera*, is worth US\$117 billion per year globally (Costanza et al. 1997) and \$8 billion per year in the U.S. (Isaacs et al. 2009). This economic importance of insect pollinators, especially honey bees, has led to widespread transport and introduction of honey bees to most regions of the globe. Recently, however, dramatic declines in pollinator abundances has generated concern for the maintenance of pollination services (Biesmeijer et al. 2006, Cox-Foster et al. 2007, Genersch 2010). The threat is 3-fold.

First, of major concern in North America is the mysterious honey bee colony collapse disorder (CCD) that has resulted in loss of 50–90% of hives in the U.S. (Cox-Foster et al. 2007). The disorder is indicated by unexplained absence of live or dead adult workers in or near hives, despite abundant brood, honey and pollen (Cox-Foster et al. 2007, R. Johnson et al. 2009). Explanations have ranged from increased exposure to pesticides, to undetected diseases, to disorientation and other stresses during the transportation of hives among agricultural regions. Claudianos et al. (2006) and Weinstock et al. (2006) reported that the honey bee genome contains

(Cont.)

substantially fewer genes for immunity or xenobiotic detoxifying enzymes, compared to other known insect genomes, explaining the greater honey bee sensitivity to pesticides. R. Johnson et al. (2009) conducted micro-array analysis of CCD and non-CCD bees and found no elevated expression of pesticide-response genes and inconclusive patterns of expression for immune genes. However, an abundance of unusual ribosomal RNA fragments, consistent with infection by picorna-like viruses, suggested that reduced protein synthesis resulting from ribosomal damage would leave bees more vulnerable to multiple additional stresses, such as pesticides or pathogens. The parasitic mite, *Varroa destructor*, is known to suppress the bee's immune system and may be acting in concert with emerging diseases to cause CCD (Genersch 2010).

Second, the abundance of native pollinators has declined in many areas, especially in agricultural regions. Many plant species, including crop species in some areas, depend primarily on native specialist pollinators, which are more efficient than is the more generalist honey bee. Native pollinators, where protected, are capable of providing full pollination service and compensating for decline or absence of honey bees (Kremen et al. 2002, Ricketts 2004). However, the abundances of native pollinators are threatened by a combination of habitat destruction (Holzschuh et al. 2007, A. Klein et al. 2003, Kremen 2005, Ricketts 2004, Taki et al. 2007, N. Williams and Kremen 2007) and competition from widely introduced honey bee populations (Aizen and Feinsinger 1994).

Finally, agricultural intensification and habitat fragmentation have isolated pollinator habitats from the crops that must be pollinated. Pollination services by native bees are positively related to the area of natural habitat in the vicinity of agricultural crops (Kremen et al. 2004, Ricketts 2004, N. Williams and Kremen 2007). Balvanera et al. (2005) found that increasingly intensive conventional agriculture resulted in loss of 60% of native bee pollinators, reduced abundances of the most functionally-important pollinators, 60–80% loss of pollination function and reduced evenness in functional structure, compared to organic agriculture within a conserved forest matrix. Wild colonies of honey bees also typically inhabit forests and suffer from forest fragmentation (e.g., Crane 1999).

A decline in pollination service clearly threatens adequate crop production for an increasingly demanding human population. However, survival of other plant species that require insect pollinators for out-crossing also may be threatened (Biesmeijer et al. 2006).

## INTRODUCTION

**INSECTS AFFECT PLANT REPRODUCTION AND ASSOCIATED PROCESSES** in a variety of ways. Direct and indirect effects of herbivores on plant production and allocation of resources to reproduction were described in [Chapter 12](#). Pollination, seed predation and seed dispersal are major processes by which insects (and other animals) affect plant reproduction and distribution. Pollinators control fertilization and reproductive rates for many plant species, especially in the tropics. In fact, some plant species depend on pollinators for successful reproduction and may disappear if their pollinators become rare or extinct (Powell and Powell 1987, Steffan-Dewenter and Tschardtke 1999). Seed predators consume seeds and thereby reduce plant reproductive efficiency, but they often move seeds to new locations and thereby contribute to plant dispersal. Many plant species depend on seed dispersers for successful movement of seeds to new habitats and may be vulnerable to disappearance of their dispersers (O'Dowd and Hay 1980, Schupp 1988, Temple 1977). Pollinators and seed predators play important roles in seed production, seedling recruitment and plant demography.

Insects are the major agents of pollination, seed predation or seed dispersal in many ecosystems (Bawa 1990, Degen and Roubik 2004, Sallabanks and Courtney 1992). For example, Momose et al. (1998b) noted that for 270 plant species in a lowland dipterocarp

forest in Sarawak, Malaysia, social bees were the primary pollinators for 44%, beetles for 24%, solitary bees for 19%, and birds and bats for 6% of these species. Pollination and seed dispersal are among the most intricate mutualisms between animals and plants, and they have been studied widely from the perspective of co-evolution. Nevertheless, few studies have evaluated the effects of pollinators, seed predators and seed dispersers on ecosystem processes, despite their importance to seedling recruitment and vegetation dynamics. Different functional groups of pollinators and seed-feeders affect seedling recruitment and vegetation dynamics in different ways.

## I. TYPES AND PATTERNS OF POLLINATION

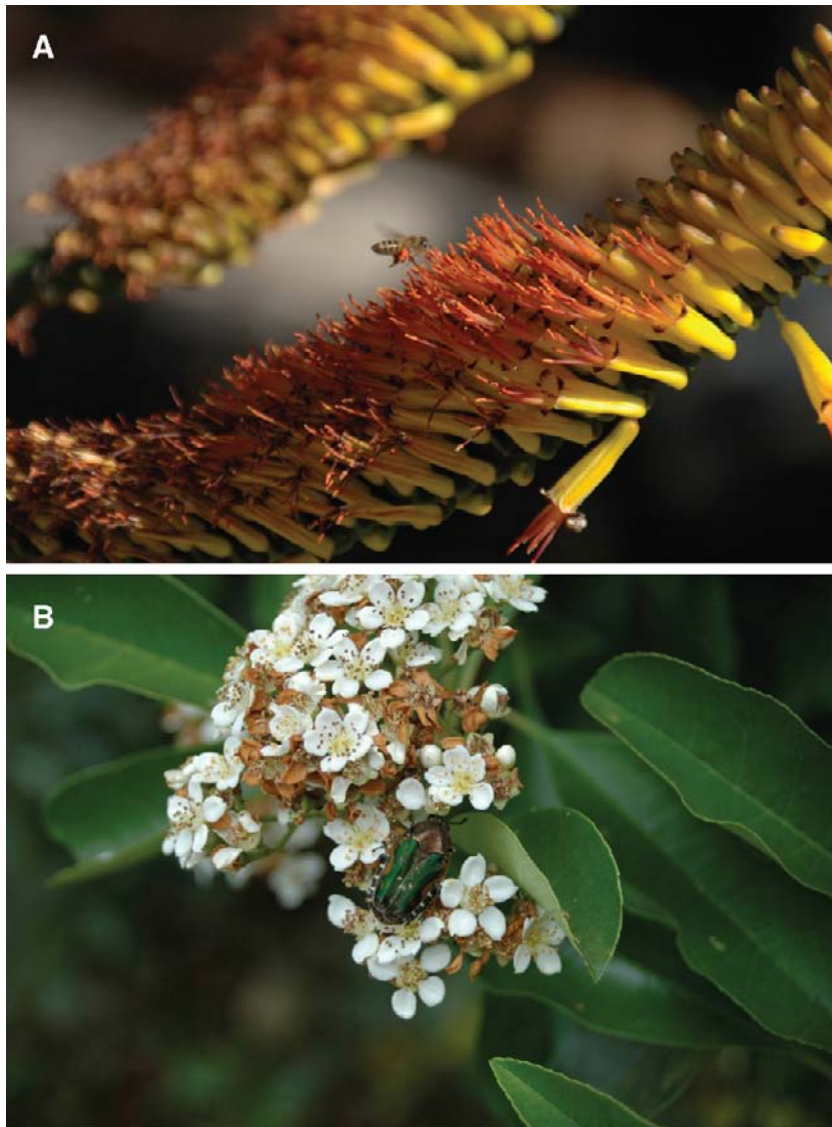
Plants exhibit a diversity of reproductive mechanisms. Many reproduce vegetatively, but this mechanism is limited largely to local reproduction. Genetic heterozygosity and colonization ability are increased by out-crossing. Although many plant species are capable of self-fertilization, a large percentage (a vast majority in some ecosystems) is self-incompatible, and many are dioecious (e.g., 20–30% of tropical tree species), with male and female floral structures separated among individual plants to preclude inbreeding (Bawa 1990, Momose et al. 1998a). Mechanisms for transporting pollen between individuals becomes increasingly critical for reproduction with increasing separation of male and female structures and increasing isolation of individual plants (Ghazoul and McLeish 2001, Regal 1982, Ricketts et al. 2008, Steffen-Dewenter and Tschardt 1999).

Several mechanisms move pollen among flowering individuals. Pollen can be transferred between plants through both abiotic and biotic mechanisms (Regal 1982). Pollen is transported abiotically by wind. Biotic transport involves insects, birds and bats (Fig. 13.1). Insects are the major pollinators for a vast majority of plant species in the tropics (Bawa 1990), but the proportion of wind-pollinated plants increases toward the poles, reaching 80–100% at northernmost latitudes (Regal 1982). These mechanisms provide varying degrees of fertilization efficiency, depending on ecosystem conditions.

### A. Pollinator Functional Groups

Functional groups of pollinators may be more or less restricted to groups of plants based on floral or habitat characteristics (Bawa 1990). A large number of pollinators are **generalists** with respect to plant species. This functional group includes honey bees and many beetles, flies, thrips, etc. that forage on any floral resources available. **Specialist** pollinators exploit particular floral characteristics that may exclude other pollinators. For example, nocturnally flowering plants with large flowers attract primarily bats, whereas plants with small flowers attract primarily moths. Long, bright red flowers attract birds but are largely unattractive to insects (S. Johnson and Bond 1994). Such flowers often are narrow to hinder entry by bees and other insect pollinators (Heinrich 1979), but nonetheless may be pollinated by some insects (Roubik 1989). **Pollen-feeders** feed primarily on pollen (e.g., beetles and thrips) and are likely to transport pollen acquired during feeding, whereas others are primarily **nectar-feeders** (e.g., beetles, butterflies, moths, and flies) and transport pollen more coincidentally. In fact, many nectar-feeders avoid the reproductive organs, often by perforating the base of the flower to reach the nectar, e.g., nectar thieves (Dedej and Delaplane 2004), or, in the case of ants, may reduce pollen viability (Peakall et al. 1987). **Bees**, especially *Apis* spp., primarily feed on pollen and nectar. Functional groupings also reflect their sensitivity and attraction to floral odors (Chittka and Raine 2006). For example, **dung-, fungus- and carrion-feeding flies and beetles** are the primary



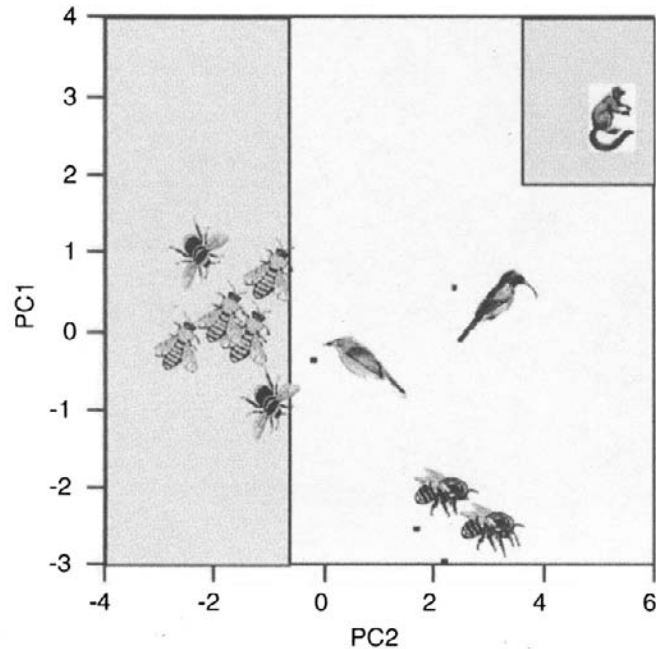


**FIG. 13.1** Examples of pollinators. A) honey bee, *Apis mellifera scutellata*, Hluhluwe National Park, South Africa. Note the pollen basket (corbicula) filled with red pollen. B) scarab beetle, Fushan Experimental Forest, Taiwan.

pollinators of plants that emit dung or carrion odors (Appanah 1990, Norman and Clayton 1986, Norman et al. 1992).

Ants frequently exploit floral resources but have little importance as pollinators. Peakall et al. (1987) suggested that antibiotic secretions produced by most ants, to inhibit infection by entomophagous fungi in a subterranean habitat, also inhibit the germination of pollen. Ants lacking these secretions are known to function as pollinators.

Pollinator functional groups also have been distinguished on the basis of habitat preferences, such as vegetation stratum (Fig. 13.2). Appanah (1990) distinguished four groups



**FIG. 13.2** Principle components analysis for pollinator partitioning by 11 species of Colleae (Bignoniaceae) trees in Madagascar, based on variation in flower size (PC1, 54% of variation among species) and phenology (PC2, 26% of variation). Timing was strongly negatively correlated with flowering height on trees. Icons represent pollinator groups. Shading indicates that, with the exception of a potentially lemur-pollinated species, trees pollinated by understory pollinators (small and medium-sized bees) are on the left, and trees pollinated by canopy pollinators are on the right. From Zjhra (2008) with kind permission of Springer Science + Business Media.

of plant–pollinator associations in a tropical lowland dipterocarp forest in Malaysia. The **forest floor stratum** was characterized by low visibility and limited airflow. Floral rewards were small, reflecting low productivity of light-limited plants and low energy requirements of associated pollinators, and flowering times were extended, thereby increasing the probability of pollination by infrequent visitors. The plant–pollinator association of this stratum was dominated largely by non-selective, low-energetic beetles, midges and other flies. These pollinators were attracted over short distances by strong olfactory cues, often resembling dung or carrion, which have limited effective range. The **understory stratum** shared many of the environmental features of the forest floor. Plants in this stratum also offered limited visual cues and floral rewards and were pollinated by non-specific trapliners, i.e., species that revisit particular plants along an established circuit (e.g., trigonid bees, solitary wasps and butterflies). The **overstory stratum** was characterized by brightly-colored flowers, held above the canopy to attract pollinators over a wide area, and brief, highly synchronized flowering within plant species. Dominant pollinators were *Apis dorsata*, and

trapliners such as carpenter bees, birds and bats. Dipterocarps in the genera *Shorea*, *Hopea* and *Dipterocarpus* formed a separate association characterized by tiny flowers with limited nectar rewards and nocturnal flowering. Thrips and other tiny, flower-feeding insects were the primary pollinators. By contrast, Sakai et al. (1999) observed that beetles (chrysomelids and curculionids), rather than thrips, were the primary pollinators of these tree species in Sarawak. Finally, some plant species representing various canopy positions were **cauliflorous**, i.e., they produced flowers along the trunk or main branches. These flowers typically were large, or small and clumped, pale colored, odiferous, and produced during a brief, highly synchronized period. Pollinators included understory and overstory insects, birds and bats. Momose et al. (1998b) noted that long-distance pollinators tended to be less common in Malaysian forests than in Neotropical forests.

Roubik (1993) examined the availability of floral resources from different canopy strata in tropical forests in Panama. Results indicated that the apparent fidelity of pollinator species to particular canopy strata reflected their preferences for particular floral resources. Most pollinator species were attracted to their preferred floral resources regardless of their location in the canopy.

In deciduous forests, understory flowering may be concentrated prior to completion of canopy closure, when solar exposure and photosynthesis are maximal (Kudo et al. 2008). However, flowering time may vary widely, depending on the end of adverse seasonal conditions. Understory plants flowering after canopy closure show reduced flowering and fruiting rates as a result of declining light level.

## B. Measurement of Pollination

Pollination efficiency reflects the probability that pollen reaches a conspecific flower. A number of factors influence the efficiency of pollen transport between conspecific reproductive structures. The mechanism of pollen transport, proximity of conspecific plants, pollinator attraction to floral structures, adaptations for carrying pollen, fidelity, and thermodynamic constraints determine the probability that a flower will receive conspecific pollen.

Several methods have been used to measure pollinator activity and pollination efficiency. Observations of the type and frequency of floral visitors can provide a measure of pollinator activity (Aizen and Feinsinger 1994, Ghazoul and McLeish 2001, Sakai et al. 1999, Steffan-Dewenter and Tschardt 1999, Steffan-Dewenter et al. 2001). Interception traps also can be used to collect insects that visit particular flowers (S. Johnson et al. 2004). The number of fertilized seeds per flower provides a measure of pollination for self-incompatible species (Steffan-Dewenter et al. 2001, S. Johnson et al. 2004). Kohn and Casper (1992) used electrophoresis to identify seeds containing alleles that did not occur in neighboring plants. G. White et al. (2002) used DNA marker techniques to measure pollen transfer among trees, *Swietenia humilis*, in isolated fragments of tropical forest in Honduras. Recently, Brosi et al. (2009) used stable isotopic ratios to evaluate stingless bee foraging patterns in a fragmented tropical forest landscape. Although this method was sufficient to distinguish bees foraging in pastures vs. forest, and demonstrated significant relationships between foraging pattern and landscape structure, it could not indicate the proportion of food obtained in different habitats.

Wind pollination is highly inefficient. The probability of successful pollen transfer by wind decreases as the cube of distance between plants (Moldenke 1976). However, plant investment in individual pollen grains is negligible, so large numbers can be produced, increasing the cumulative probability that some will land on conspecific reproductive

structures. Directed transport of pollen by animal pollinators increases efficiency to the extent that the pollinator visits a conspecific flower before the pollen is lost or contaminated with pollen from other plant species. Hence, animal-pollinated plant species may invest energy and nutrients in adaptations to improve the fidelity of the pollinator. These adaptations include nectar rewards to attract pollinators, floral and aromatic advertisements, floral structures that restrict the diversity of pollinators visiting the flowers, synchronized flowering among conspecific individuals, and divergence in time of flowering among plant species to reduce pollen contamination (Chittka and Raine 2006, Heinrich 1979).

Nectar rewards must be sufficient to compensate the pollinator for the foraging effort. For example, Petanidou and Vokou (1990) reported that pollen of wind-pollinated plants provided lower energy content than did pollen of insect-pollinated plants in Mediterranean ecosystems. A greater nectar return is necessary to attract bees during cooler periods, when energy allocation to thermoregulation is high, compared to warmer periods (Heinrich 1979). Heinrich (1979) noted that pollinator fidelity reflects offsetting adaptations. Plants invest the minimum amount of energy that is necessary to reward pollinators, but pollinators quickly learn to concentrate on flowers offering the greatest rewards (Chittka et al. 1997). Individual plants in aggregations could attract bees and be pollinated even if they produced no nectar, provided that their neighbors produced nectar. The non-producers should be able to invest more energy in growth and seed production. However, if these “cheaters” became too common, pollinators might switch to competing plant species that offered greater food rewards (Feinsinger 1983). Theis and Raguso (2005) reported that some plant species dramatically reduce floral scent emission rates following pollination, thereby communicating prior visitation, and honey bees were three times more likely to visit unpollinated than pollinated flowers. Some Australian orchids apparently produce chemical signals that are similar to ant and wasp mating pheromones and exploit the male ants and wasps that pollinate these orchids while attempting to copulate with the orchid (Peakall and Beattie 1996).

A. Lewis (1993) suggested that floral characteristics may reflect advantages accruing to the plant when pollinators must make a substantial investment in learning to handle a flower, thereby becoming facultative specialists. Plant investment in attractants and rewards for pollinators represents an evolutionary trade-off between growth and reproduction (Heinrich 1979) and may affect the ability of light- or resource-limited species to attract pollinators. On the other hand, pollinator choice among floral resources that vary in quality represents a trade-off between investment in recognition of high-quality resources and accuracy of discrimination (Chittka and Raine 2006).

The effects of pollination on plant seedling recruitment and ecosystem processes have been measured less frequently. Effects on seed production can be measured as the number of seeds produced when pollinators have access or are excluded from flowers (S. Johnson et al. 2004, Norman and Clayton 1986, Norman et al. 1992, Steffan-Dewenter and Tscharrnke 1999, Steffan-Dewenter et al. 2001). Pollinator effects on ecosystem processes should reflect their direct influence on plant reproduction and indirect influence on vegetation dynamics.

### C. Spatial and Temporal Patterns of Pollination

Pollination by insects is more prevalent in some types of ecosystems than in others. Pollination by animals is more common in angiosperm-dominated ecosystems than in gymnosperm-dominated ecosystems, but pollination by wind is energetically efficient for dominant species in grasslands and temperate forests.

The regularity with which conspecific plants occur in close proximity to each other largely determines their pollination mechanism. Long-lived species that dominate relatively simple ecosystems, i.e., grasslands and temperate forests, are pollinated primarily by wind. These plant species do not require efficient pollination or frequent reproduction to ensure population survival. Energetically inexpensive transport of pollen by wind provides sufficient pollination (and successful reproduction) so that energy need not be diverted to production of expensive nectar rewards and floral displays to advertise availability.

Directed transport of pollen by animals is critical to the reproduction of plant species that are short-lived, sparsely distributed, or occur in habitats with restricted airflow (Appanah 1990, Moldenke 1979, Regal 1982, Somanathan et al. 2004). In contrast to long-lived plants, short-lived plants have limited opportunities for future reproduction and, therefore, tend to depend on more efficient pollination to ensure seed production. Sparsely distributed plants and plants in areas of limited airflow cannot rely on the inefficient transport of pollen by wind between distant or inaccessible individuals. Such species include early successional plants dominating ephemeral communities, widely-spaced plants in harsh environments (e.g., deserts), scattered forbs in grasslands, subdominant trees, shrubs and herbs in temperate forests, and all, or most, plant species in tropical forests (S. Johnson et al. 2004, Momose et al. 1998b, Regal 1982). Regal (1982) reported that fewer than 6% of desert shrub species are wind pollinated. All of the 270 plant species in a lowland dipterocarp forest in Sarawak, Malaysia, were animal pollinated, 90% by insects (Momose et al. 1998b). Bawa (1990) reviewed studies that demonstrated long-distance pollen flow and out-crossing for tropical canopy trees, but a high degree of inbreeding for many tropical herbs and shrubs.

Insects and other animal pollinators can transport pollen over considerable distances. Kohn and Casper (1992) documented gene flow among bee-pollinated buffalo gourds, *Cucurbita foetidissima*, over distances up to 0.7 km in New Mexico, U.S. Somanathan et al. (2004) reported that carpenter bees, *Xylocopa tenuiscapa*, pollinated Neotropical trees, *Heterophragma quadriloculare*, that were isolated from pollen sources by as much as 330 m, permitting reproduction by spatially isolated trees. G. White et al. (2002) identified sources of pollen reaching isolated *S. humilis* trees and forest fragments in Honduras. Substantial proportions of pollen were transported over distances from 1.5 km to more than 4.5 km between fragments. By contrast, a Neotropical shrub, *Lasiosiphon eriocephalus*, pollinated by a weakly-flying nitidulid beetle, may be particularly vulnerable to isolation or fragmentation (Somanathan et al. 2004). Duncan et al. (2004) reported that out-crossed conspecific pollen receipt on flowers declined significantly with increasing plant isolation over distances of 50 m, even though a constant rate of heterospecific pollen deposition indicated that visitation by pollinators was not reduced. These results likely reflect increased pollinator switching among floral species as distance increases (Chittka et al. 1997).

Roubik (1989) reviewed studies that distinguished seasonal patterns of pollinator activity. Primary pollinators typically were most active during periods of peak flowering. Heithaus (1979) reported that megachilid and anthophorid bees were most active during the dry season in Costa Rica, halictid bees during both wet and dry seasons, and andrenid and colletid bees during the wet season or during both seasons. Social pollinators (e.g., apid bees) require a sequence of floral resources throughout the year to support long-lived colonies, and visit a succession of flowering plant species, whereas more ephemeral, solitary species with short life spans can be relatively more specialized on seasonal floral resources (S. Corbet 1997, Roubik 1989).

## II. EFFECTS OF POLLINATION

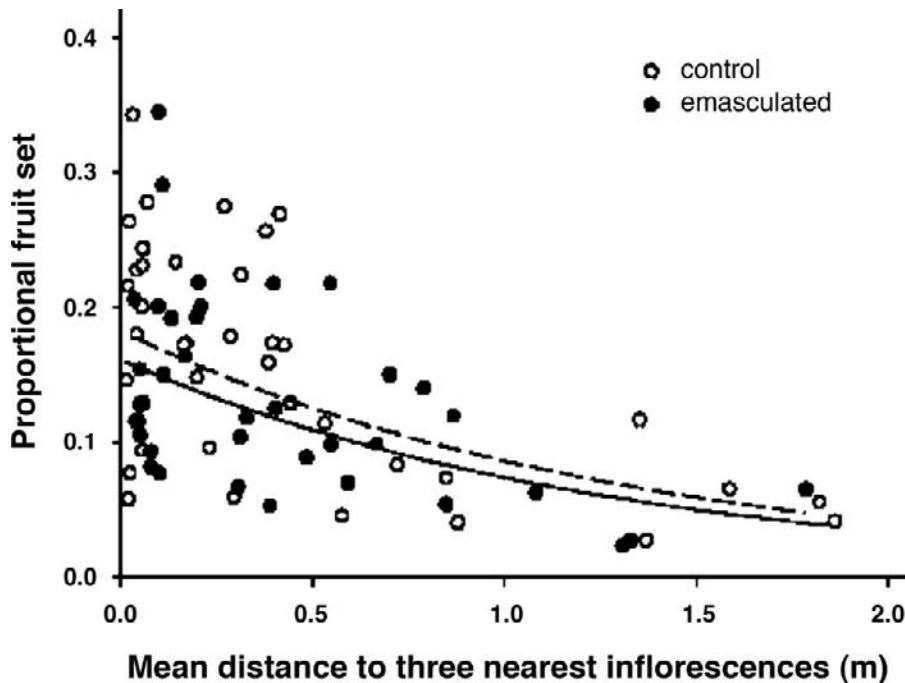
Pollination contributes to the genetic recombination and survival of plant species in heterogeneous environments. Many plants can reproduce vegetatively or by self-fertilization, but these mechanisms are not conducive to long distance colonization or genetic recombination. Species survival and adaptation to changing environmental conditions requires out-crossing and environmental selection among diverse genotypes. Some long-lived perennials may endure adverse conditions and persist by vegetative reproduction until conditions favor out-crossing and seedling recruitment. Such windows of opportunity are unpredictable, requiring annual investment in flower and seed production (Archer and Pyke 1991).

Pollinator-facilitated reproduction is a key factor maintaining populations of ephemeral or sparsely-distributed plant species. Obligate out-crossing plant species that depend on insect or vertebrate pollinators for pollination are vulnerable to loss of these mutualists. Maintenance of rare plant species or restoration of declining species depends to a large extent on the protection or enhancement of associated pollinators (Archer and Pyke 1991, S. Corbet 1997). Norman and Clayton (1986) and Norman et al. (1992) found that pawpaws, *Asimina* spp., in Florida, U.S., depended on beetle and fly pollinators that were attracted to yeasty floral odors. Self-pollinated flowers occasionally produced fruits, but only seeds from cross-pollinated flowers germinated.

The efficiency of pollination by insects is strongly affected by flower size or attractiveness and plant spacing (Brys et al. 2008, Dauber et al. 2010). Mustajärvi et al. (2001) reported that bumble bees, *Bombus* spp., preferred larger populations of *Lychnis viscaria*, but visitation rates were higher in sparse populations, where the large flowers of this plant were more visible. Momose et al. (1998a) found that pollination by thrips and consequent fruit and seed development of a small (< 8 m height) tree species, *Popowia pisocarpa*, in Sarawak declined dramatically when distances between trees exceeded 5 m. Brys et al. (2008) demonstrated that pollination efficiency, pollen transport and fruit set for 13 populations of a European orchid, *Listera ovata*, increased with local population size up to 30–40 flowering plants, above which pollination efficiency and plant reproduction declined again. Changes in pollinator abundances and pollination efficiency affect plant population dynamics and persistence in communities. Environmental changes that increase the distance between conspecific plants may threaten their survival, as shown in the following examples.

Steffan-Dewenter and Tschardtke (1999) examined the effects of plant isolation on pollination and seed production in replicate grasslands surrounded by intensively managed farmland. They established small experimental patches of two grassland species, *Sinapsis arvensis* and *Raphanus sativus*, at increasing distances from the grassland boundaries and found that the number and diversity of bees visiting flowers, and seed production, declined with increasing isolation. Number of seeds per plant was reduced by 50% at 260 m from the nearest grassland for *R. sativus* and at 1000 m for *S. arvensis*. Brys et al. (2008) also reported decline in pollination over short distances of separation among conspecific flowering plants (Fig. 13.3). Ricketts et al. (2008) conducted a meta-analysis of isolation studies and concluded that the distance at which native pollinator visitation rate declines to 50% of maximum is 590 m in tropical ecosystems and 1300 m in temperate ecosystems (Fig. 13.4).

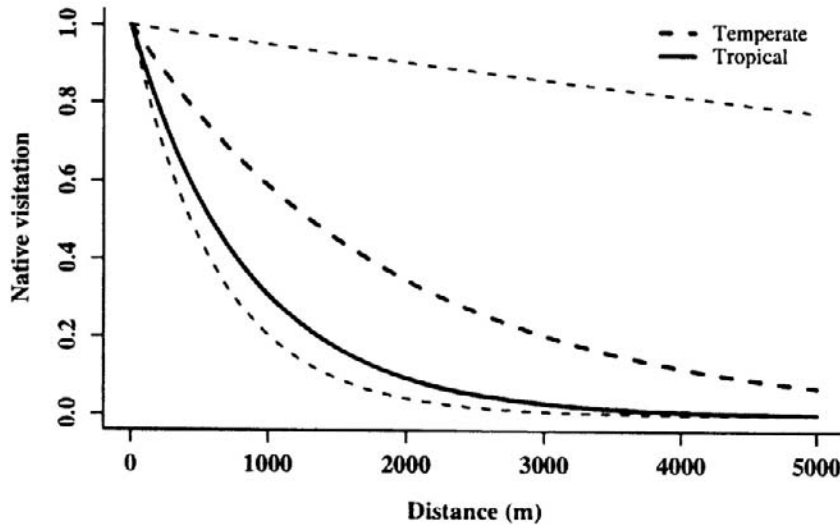
Changes in pollinator abundance, such as those resulting from ecosystem fragmentation, can affect plant reproduction and gene flow (Bawa 1990, Didham et al. 1996). Powell and Powell (1987) compared the attraction of male euglossine bees to floral chemical baits in forest fragments in Brazil. Abundance and species composition did not differ among



**FIG. 13.3** Effect of local plant density (mean distance to the three nearest flowering plants) on proportional fruit set in emasculated plants (filled circle, solid regression line) and control plants (open circle, dashed regression line) within a large *Listera ovata* population ( $N = 1524$ ). The emasculation treatment indicated the effect of distance on cross-fertilization. From Brys et al. (2008) with permission from John Wiley & Sons.

sites prior to fragmentation. However, after fragmentation, visitation rates for most species were correlated to fragment size, and the bee species trapped in clearings differed from those trapped in forests (Fig. 13.5). Powell and Powell (1987) concluded that the reduced abundance and activity of particular pollinators in fragmented forests threatened the viability of their orchid hosts. Aizen and Feinsinger (1994) compared pollinator visitation among replicated blocks containing continuous forest and large (>2.2 ha) and small (<1 ha) fragments, in subtropical dry forest in northwestern Argentina. The diversity and visitation frequency of native pollinators decreased significantly, and the visitation frequency of exotic honey bees, *A. mellifera*, increased significantly, with decreasing fragment size (Fig. 13.6). Fragments supported fewer bee species than did continuous forests. Although honey bees from the surrounding agricultural matrix replaced most of the lost visitation by native pollinators, some plant species could be threatened by loss or reduced specificity of pollinators.

Although much research has demonstrated the critical role of adequate pollination for reproduction by many plant species, as described above, virtually none has addressed the effects of pollinators on plant community structure and the dependent web of direct and indirect interactions. Differential reproductive success among plant species affects vegetation dynamics. Therefore, pollinator choices among floral resources that vary in nutritional quality could affect vegetation dynamics and community structure (Quesada et al. 2009). For example, rewardless orchids might appear to have a disadvantage in attracting

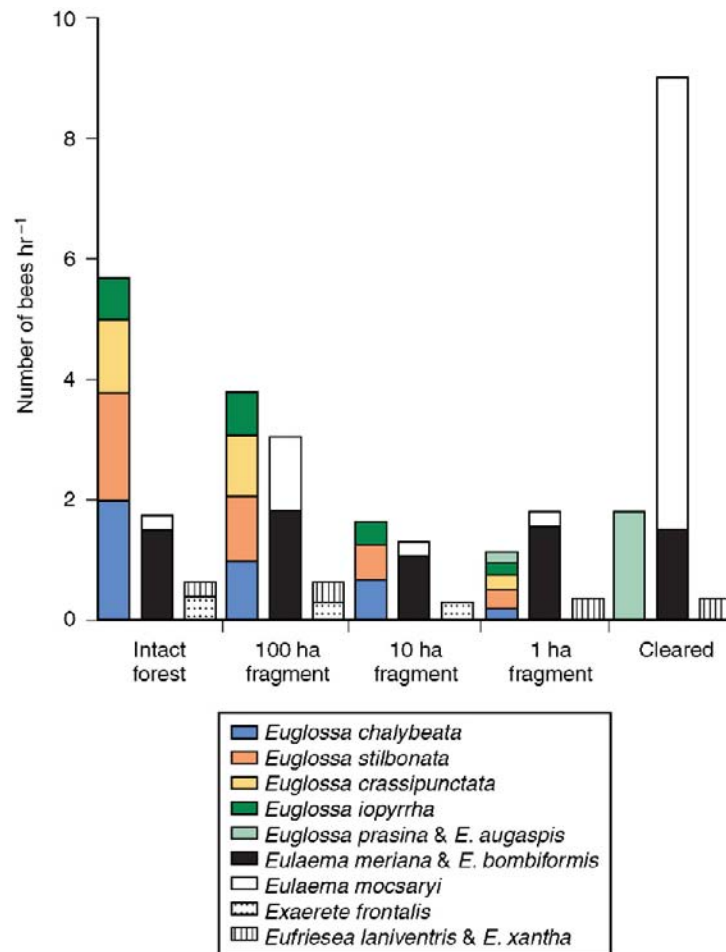


**FIG. 13.4** Relationship between plant distance from population sources and the rate of native pollinator visitation in temperate and tropical ecosystems. Shaded area represents 90% confidence interval for tropical studies ( $n=11$ ); light dashed lines represent 90% confidence interval for temperate studies ( $n=11$ ). Distances at which native pollinator visitation drops to 50% of maximum is 590 m for tropical systems and 1300 m for temperate systems. From Ricketts et al. (2008) with permission from John Wiley & Sons.

pollinators. Galizia et al. (2005) compared the visual and olfactory floral cues of a rewardless orchid, *Orchis israelitica*, and its lily model, *Bellevalia flexuosa*. The orchid displayed visual, but not olfactory, mimicry. Nevertheless, bees readily switched between the two plant species, indicating the dominance of visual stimuli in short-range floral choice. However, Chittka et al. (1997) reported that foraging bumble bees, *Bombus* spp., were more likely to switch to a different floral species after a short visit, indicative of low nectar reward, than after a long visit or when the floral species was rare. Overall, bees remained faithful to a particular species as long as rewards were sufficient and plants were close together, but switched when rewards were low or plants were not encountered at close range. Gumbert et al. (1999) found that rare plant species provided more distinct floral signals, which, combined with greater reward, would compensate pollinators for greater travel distances (Heinrich and Raven 1972). Burkle and Irwin (2009, 2010) experimentally increased nitrogen availability to subalpine plant assemblages to evaluate the effects on pollinator visitation rates. They found that pollinator visitation rate was unaffected by this bottom-up enrichment. Pollinators distributed their visitation evenly among floral resources, regardless of nitrogen treatment.

Although these studies have indicated considerable switching among floral resources by generalist pollinators, many plants compete for pollinators and may suffer from pollen limitation (Knight et al. 2005b, R.J. Mitchell et al. 2009, Quesada et al. 2009). Pollen limitation is significantly positively related to plant species richness, making the most diverse communities most vulnerable to species decline and replacement as a result of reproductive failure (Quesada et al. 2009, Vamosi et al. 2006). Changes in the relative abundances of specialist and generalist pollinators would influence vegetation structure and composition. Reduced abundances of specialist pollinators, in particular, are likely





**FIG. 13.5** Rates of visitation by male euglossine bees at chemical baits in intact forest, forest fragments of varying size (100 ha, 10 ha and 1 ha), and recently deforested (500 ha). Modified from Powell and Powell (1987) with permission from the Association for Tropical Biology.

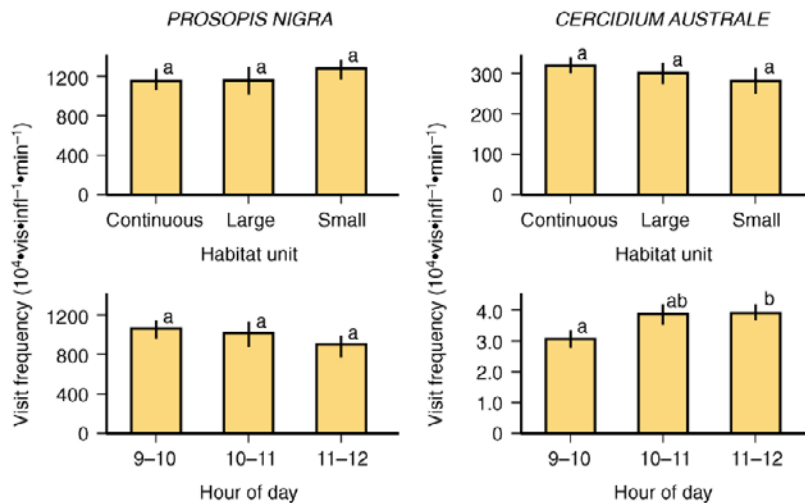
to threaten the survival of some plant species and result in shifts in plant community composition.

Pollination also contributes to the production of fruits and seeds that support associated food webs. Many animal species depend on fruit and seed production, at least seasonally (see below). Hence, pollination of fruiting plants has consequences not only for plant reproduction, but also for the survival of frugivores and seed predators (Bawa 1990).

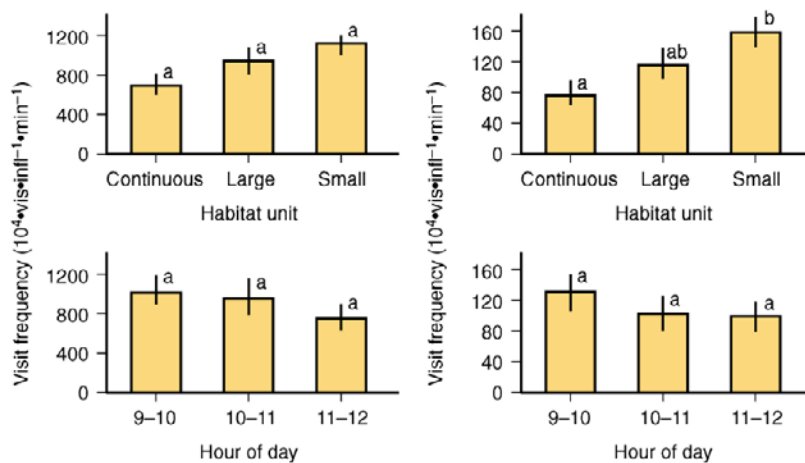
Pollinators can affect ecosystem energy and nutrient fluxes through transport of energy- and nutrient-rich nectar and pollen. Roubik (1989) calculated the effects of social bees

**FIG. 13.6** Rates of visitation by all pollinating insects, exotic honey bees, *Apis mellifera*, alone, and native pollinators alone on flowers of two plant species by treatment (continuous forest, and large (2.2 ha) and small (1 ha) fragments) and by time of day in Argentina. Vertical lines represent standard errors; bars under the same letter do not differ at  $P < 0.05$ . From Aizen and Feinsinger (1994) with permission from the Ecological Society of America.

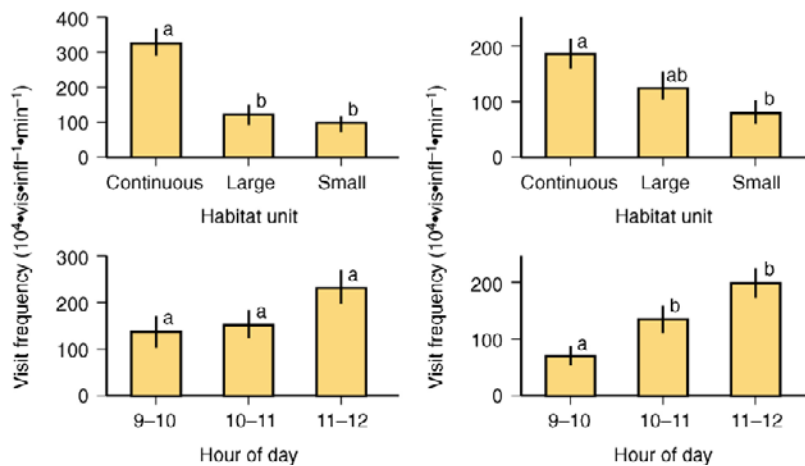
ALL INSECTS



A. MELLIFERA



ALL BUT A. MELLIFERA



on energy and nitrogen budgets of tropical forests in Central America. He estimated that 600 colonies  $\text{km}^{-2}$  harvested  $1.4 \times 10^7 \text{kJ yr}^{-1}$  and disposed of an equivalent energy value represented by dead bees scattered on the ground within a few dozen meters of each nest. This value exceeded estimates of energy fixed annually by primary producers, indicating that the energetics of flowering are greatly underestimated (Roubik 1989). The 600 colonies also distributed about 1800 kg trash (pupal exuviae and feces)  $\text{ha}^{-1} \text{yr}^{-1}$ . At 4% nitrogen content, this represents a flux of 72 kg  $\text{ha}^{-1} \text{yr}^{-1}$  or about 1% of above-ground nitrogen in biomass. Pollinator effects on community structure also should affect ecosystem processes. These effects warrant further study.

### III. TYPES AND PATTERNS OF SEED PREDATION AND DISPERSAL

The fate of seeds is critical to plant reproduction. A variety of animals feeds exclusively or facultatively on fruits or seeds, limiting potential germination and seedling recruitment. Many animals, especially frugivores, facilitate seed dispersal. Dispersal of seeds is necessary for colonization of new habitats, and for escape from high mortality near parent plants, but relatively few studies have measured the advantages of seed dispersal to plant fitness (Howe and Smallwood 1982). In contrast to pollination, effective seed dispersal relies less on disperser specialization than on movement to suitable habitat (Wheelwright and Orians 1982). These mechanisms confer varying degrees of dispersal efficiency and advantages for seedling growth, depending on ecosystem conditions.

#### A. Seed Predator and Disperser Functional Groups

Fruits and seeds are highly nutritive food resources, as a consequence of plant provision of resources for germination and, often, attraction of dispersal agents. A wide variety of animals feeds on fruits or seeds. For example, Turgeon et al. (1994) reported that more than 400 species of insects, representing seven orders, feed on conifer cones and/or seeds. Some species are obligate fruit- or seed-feeders, whereas others feed primarily on other resources but exploit fruits and/or seeds when available.

Seed dispersal can be accomplished through both abiotic and biotic mechanisms. Abiotic dispersal involves wind and water; biotic dispersal involves autogenic mechanisms, such as explosive fruits, and various animal agents, including insects, fish, reptiles, birds and mammals. Dispersal by animals is typically a consequence of frugivory or seed predation, but some species acquire seeds or spores through external attachment by various kinds of clinging devices, e.g., sticky material or barbed spines. Seeds of a majority of plant species are dispersed by animals in many ecosystems (Howe and Smallwood 1982).

Seed predator and seed disperser functional groups can be distinguished on the basis of consumption of fruits or seeds vs. transport of seeds. **Frugivores** feed on fleshy fruits and may terminate fruit or seed development (Sallabanks and Courtney 1992), but many vertebrate frugivores (including fish, reptiles, birds and mammals) consume entire fruits and disperse seeds that are adapted to survive passage through the digestive tract (Correa et al. 2007, Crawley 1989, de Souza-Stevauz et al. 1994, M. Horn 1997, Sallabanks and Courtney 1992, Temple 1977). **Seed predators** include a number of insect, bird and rodent species that consume seeds where found. Some seed predators eat the entire seed, e.g., vertebrates and ants, but others penetrate the seed coat and consume only the endosperm, e.g., seed bugs (Lygaeidae and Coreidae) and weevils (Curculionidae) or develop and feed within the seed, e.g., seed wasps (Torymidae) and seed maggots (Anthomyiidae)

(J. Brown et al. 1979, Crawley 1989, Honek et al. 2009, Louda et al. 1990b, Schowalter 1993, Turgeon et al. 1994). **Seed cachers** eat some seeds and move others from their original location to storage locations. Although ants and rodents are best known for caching seeds (J. Brown et al. 1979), at least one carabid beetle, *Synuchus impunctatus*, caches seeds of *Melampyrum* in hiding places after consuming the caruncle at the end of the seed (Manley 1971). **Seed vectors** include primarily vertebrates that carry seeds that are adapted to stick to fur or feathers. Insects are generally too small to transport seeds in this way, but they often transmit the spores of microorganisms adapted to adhere to insect exoskeletons or pass through insect digestive systems.

These functional groups can be subdivided on the basis of pre- or post-dispersal seed predation, seed size, etc. Pre-dispersal frugivores and seed predators feed on the concentrated fruits and seeds developing on the parent plant, whereas post-dispersal frugivores and seed predators must locate scattered fruits and seeds that have fallen to the ground. Rodents and birds typically exploit larger seeds than do insects, and species within taxonomic groups also partition seeds on the basis of size (e.g., J. Brown et al. 1979, Davidson et al. 1984, Whitford 1978). Vertebrates are more likely to disperse seeds from consumed fruits than are insects, which (due to their small size) typically feed on portions of fruits and on or in seeds. However, dung beetles and ants may be important secondary dispersers, redistributing seeds from animal dung (Andresen 2002, Martínez-Mota et al. 2004). Insects, especially ants, are more likely to disperse small seeds, particularly of plant species adapted for dispersal by ants (myrmecochory).

## B. Measurement of Seed Predation and Dispersal

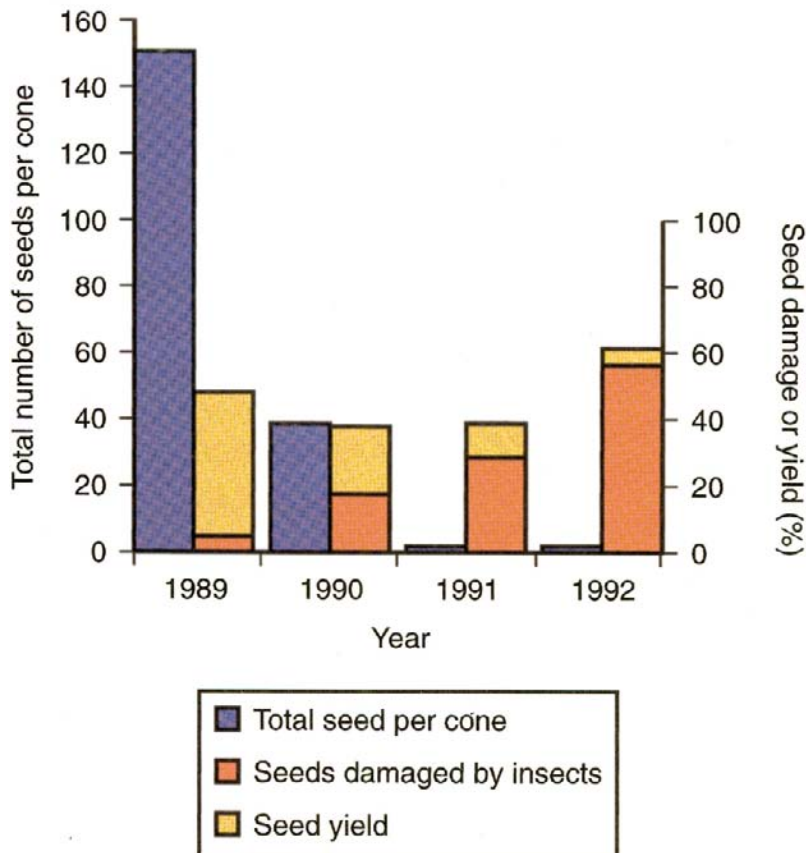
A number of factors influence rates of seed predation and dispersal. The extent of seed mortality, mechanism of seed transport, distance moved from the parent plant, attraction of particular dispersal agents, and thermodynamic constraints determine the probability that seeds will survive and be moved to suitable or distant locations. Pollinators and seed predators can have opposing effects on seed production. Steffan-Dewenter et al. (2001) reported that pollinator activity decreased, but seed predation increased, on experimental *Centaurea jacea* plants with distance from semi-natural habitats in an agricultural landscape in Germany.

Several methods have been used to measure seed predation and dispersal. Pre-dispersal seed predation can be measured by marking fruits and/or seeds on the plant and observing their fate, using a life table approach (see Chapter 5). Mature fruits and seeds can be collected for emergence of seed predators (Steffan-Dewenter et al. 2001) or dissected or radiographed for identity and number of internal seed predators or evidence of endosperm digestion by Hemiptera (e.g., Schowalter 1993). Seed piercing Hemiptera may leave detectable pectinases or stylet sheaths on the seed coat of consumed seeds (Campbell and Shea 1990). Post-dispersal seed predation can be measured by placing marked seeds on the ground and measuring their rate of disappearance (C. Chapman and Chapman 1996, Côté et al. 2005, Heithaus 1981, Honek et al. 2009, O'Dowd and Hay 1980, Schupp 1988). Marked seeds (e.g., with stable isotopes) can be identified in caches or fecal material for assessment of seed dispersal rate (e.g., O'Dowd and Hay 1980).

Seed predators are capable of consuming or destroying virtually the entire production of viable seed of a given plant species in some years (Coe and Coe 1987, Ehrlén 1996, Honek et al. 2009, Horvitz et al. 2005, Robertson et al. 1990, Schowalter 1993, Turgeon et al. 1994). The intensity of seed predation depends to a large extent on seed availability.

Seed predators focus on the largest or most concentrated seed resources (Ehrlén 1996). During years of poor seed production, most or all seeds may be consumed, whereas during years of abundant seed production, predator satiation enables many seeds to survive (Schowalter 1993, Turgeon et al. 1994). Long-lived plant species only need to produce a few offspring over time to balance mortality. Hence, many tree species produce abundant seed only once every several years. Years of abundant seed production are known as mast years. Poor seed production during the intervening years reduces seed predator populations and increases efficiency of seed production during mast years (Fig. 13.7).

Insects are generally more important pre-dispersal seed predators than are vertebrates, but vertebrates are more important post-dispersal seed predators (Crawley 1989, Davidson et al. 1984, Louda et al. 1990b, Schupp 1988). Pre-dispersal seed predators greatly reduce seed production efficiency and reduce the number of seeds available for post-dispersal seed predators and dispersal. K. Christensen and Whitham (1991) reported that seed-dispersing birds avoided foraging in piñon pine trees in which the stem- and cone-boring moth, *Dioryctria albovitella*, had inhibited cone development and increased cone mortality. At the same time, frugivores and post-dispersal seed predators consume colonized seeds and can significantly reduce populations of pre-dispersal seed predators

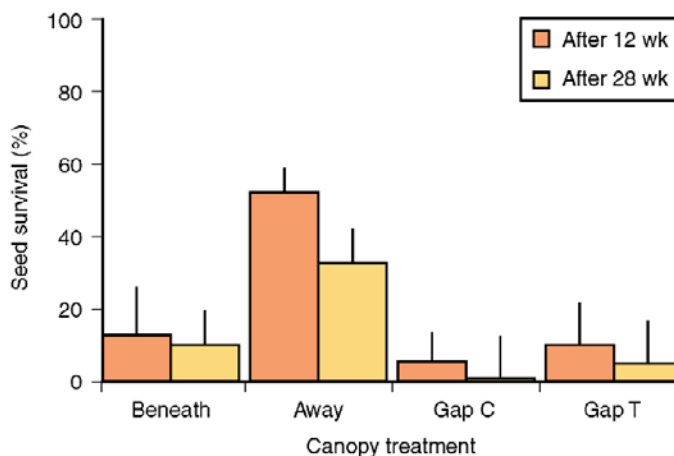


**FIG. 13.7** Relationship between total seed produced, seed loss to insects, and seed yield in a Douglas-fir seed orchard in western Oregon. Data from Schowalter (1993).

(Coe and Coe 1987, Herrera 1989). Sallabanks and Courtney (1992) suggested that seed predators and dispersers often may exert opposing selection pressures on temporal and spatial patterns of fruit and seed production.

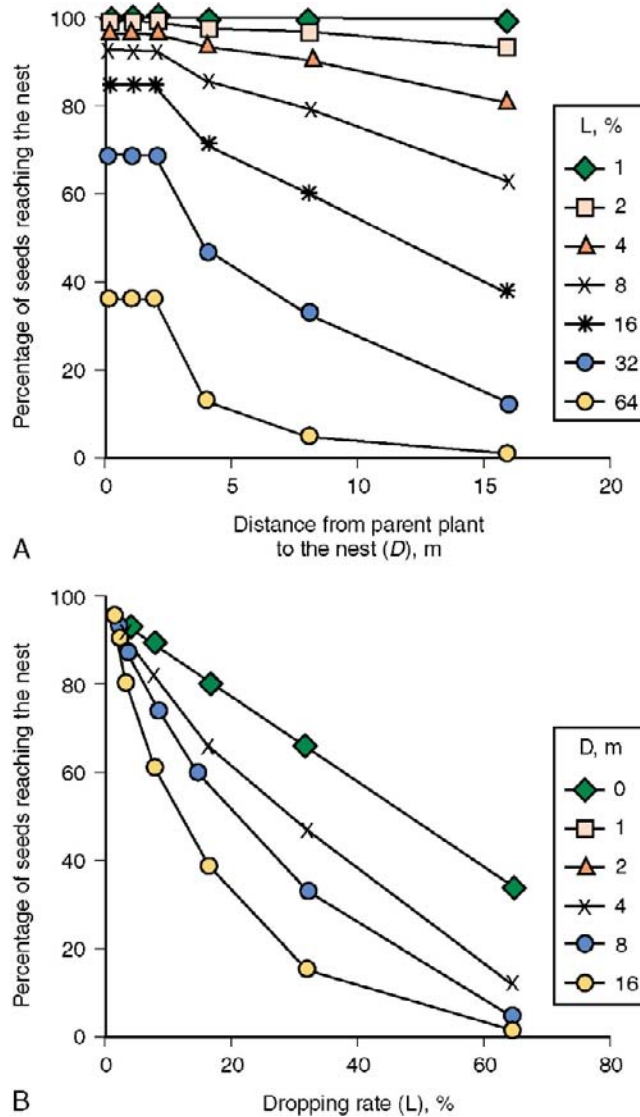
Seed dispersal is an important mechanism for plant colonization of new sites. However, dispersal also may increase seed and seedling survival. Schupp (1988) reported that vertebrate seed predators limited seed survival under the parent tree to 15% of marked seeds, but that dispersal distances of only 5 m significantly increased seed survival to nearly 40% over a seven month period (Fig. 13.8). C. Chapman and Chapman (1996) compared fruit and seed disappearance and survival of seeds remaining under the parent canopy for six tree species in a tropical forest in Uganda. Three of the six species showed higher rates of seed removal at locations away from the parent canopy, compared to locations under the parent canopy, whereas the other three species showed no difference in seed removal between locations. However, for two of the latter species, survival of transplanted seedlings was much higher under conspecific canopies than at locations away from conspecifics, but subsequent herbivory tended to be higher on seedlings under conspecific trees. Fruits not harvested by dispersers typically rot on the ground, destroying the seeds within (Asquith et al. 1999, Janzen and Martin 1982). Ants often play a critical role in seedling survival and germination by foraging on fruit, cleaning seeds, and dispersing them to ant nests (Oliveira et al. 1995, Passos and Oliveira 2003). Seeds not cleaned by ants succumb to decay. These results indicate that seed dispersal to suitable sites represents various trade-offs. Nevertheless, the efficiency with which seeds reach favorable sites is critical to plant population dynamics.

Seeds transported by wind or water often have low dispersal efficiency, for which plants must compensate by producing large numbers of seeds. Animals are presumed to be more efficient dispersal agents, but this may not always be accurate. Seeds dropped from animal vectors are no more likely to land on suitable germination sites than are seeds deposited by wind or water, unless animal dens or habitats provide suitable germination sites. However, the direction of animal movement is more variable than that of wind or water.



**FIG. 13.8** Survival of *Faramaea occidentalis* seeds beneath fruiting parent trees (Beneath), away from parent trees (Away; 5 m from crown perimeter of nearest fruiting adult), and within the canopy (Gap C) and trunk (Gap T) zones of treefall gaps on Barro Colorado, Panama. Survival of seed was significantly ( $P < 0.05$ ) higher 5 m from parent trees than beneath parent trees or in treefall gaps. Data from Schupp (1988).

Birds, in particular, quickly cover large areas, but local seed redistribution by ants also can significantly affect plant demographics (Gorb and Gorb 2003, O' Dowd and Hay 1980). A number of plant species are specifically adapted for seed dispersal by animals. Myrmecochorous species produce a lipid-rich elaiosome to attract ants, which move seeds variable distances, depending on whether the elaiosome is removed prior to or during transport or at the nest (Fig. 13.9, Gorb and Gorb 2003). Some species with large seeds or thick seed



**FIG. 13.9** Relationship between seed number transported to ant nests and distance from the parent plant to the nest, for given diaspore dropping rates (A) and relationship between seed number transported to nests and dropping rate of diaspores, for given distances from the nest (B). From Gorb and Gorb (2003) with kind permission of Springer Science + Business Media.



**FIG. 13.10** Dung beetles represent secondary dispersers of seeds in vertebrate dung.

coats may show reduced dispersal or germination ability where movement by animals or seed scarification are prevented (Culver and Beattie 1980, Oberrath and Böhning-Gaese 2002, Temple 1977). However, many seeds are dispersed more passively by various animals, including secondary dispersers such as dung beetles that redistribute frugivore dung (Fig. 13.10).

Seed storage underground by ants and rodents may move seeds to sites that have better soil conditions or reduce vulnerability to further predation. A number of studies have demonstrated that seedlings germinating in ant nests are larger and have higher survival rates than do seedlings emerging elsewhere (A. Andersen 1988, Bennett and Krebs 1987, Culver and Beattie 1980, Rissing 1986, D. Wagner 1997). Ant nests may or may not enrich surrounding soils (Horvitz and Schemske 1986, Westoby et al. 1991, see Chapter 14). Soil from ant nests often has significantly higher concentrations of nitrate, ammonium, phosphorus and water and higher nitrogen mineralization rates than does soil away from nests (A. Andersen 1988, Culver and Beattie 1983, Herzog et al. 1976, Lesica and Konnowski 1998, D. Wagner 1997, D. Wagner et al. 1997). On the other hand, Rice and Westoby (1986), L. Hughes (1990), and Gorb and Gorb (2003) found that myrmecochorous plants do not necessarily show distribution patterns that are associated with soil fertility or with ant nests. Gorb and Gorb (2003) found that foraging *Formica polyctena* transported myrmecochorous seeds to territorial borders after removing the elaiosome, thereby distributing seeds widely, but non-myrmecochorous seeds were transported to nests, where they remained, leading to increased competition among plants that grew on the mound.

Plants may benefit from seed deposition at suitable depths for germination or protection from intense predation by vertebrates (Cowling et al. 1994). Shea et al. (1979) found that



germination of serotinous seeds of several legume species, in Western Australia, was enhanced by seed redistribution by ants to depths that were heated sufficiently, but protected from higher surface temperatures, during high intensity autumn fires. O'Dowd and Hay (1980) reported that transport of diaspores of *Datura discolor* by ants, to nests averaging only 2.3 m from the nearest plant, reduced seed predation by desert rodents from 25–43% of seeds in dishes under parent plants to <1% of seeds in dishes near ant nests. Heithaus (1981) found that when seed dispersal by ants was experimentally prevented, rodents removed 70–84% of *Asarum canadense* and *Sanguinaria canadensis* seeds, compared to 13–43% of seeds lost when ants were present. Furthermore, laboratory experiments demonstrated that rodents located buried seeds less frequently than seeds on the surface and consumed buried seeds less often when elaiosomes were removed, as done by ants. L. Hughes (1990) reported that changes in nest structure, indicated by relocation of nest entrances, may provide refuges for seeds remaining in abandoned portions of nests and reduce seedling competition by preventing long-term concentration of seeds in localized sections of nests.

### C. Spatial and Temporal Patterns of Seed Predation and Dispersal

Few studies have compared seed predation and dispersal among ecosystems. Different agents dominate these processes in different ecosystems (Moll and McKenzie 1994). For example, dominant plant species in temperate, especially arid, ecosystems frequently have wind-dispersed seed, whereas plant species on oceanic islands often are water-dispersed (Howe and Smallwood 1982). Howe and Smallwood (1982) concluded that consistently windy ecosystems promote wind-driven dispersal, whereas more mesic conditions promote animal-driven dispersal. Old World deserts have relatively few (< 5%) animal-dispersed plant species (Howe and Smallwood 1982). More than 60% of temperate and tropical forest plant species are dispersed by animals (Howe and Smallwood 1982). A variety of large vertebrate herbivores are important frugivores and seed dispersers in temperate and tropical ecosystems (e.g., Janzen and Martin 1982). Fruits and seeds in seasonally-flooded tropical forests often are dispersed by fish during periods of inundation (de Souza-Stevaux et al. 1994, M. Horn 1997, Howe and Smallwood 1982). Bats and primates are more important frugivores and seed dispersers in tropical forests than in temperate ecosystems. Insects are ubiquitous frugivores and seed predators, but they may be more important dispersers in grassland and desert ecosystems, where transport to ant nests may be critical to protection of seeds from vertebrate seed predators, from competition, and from fire (e.g., Louda et al. 1990b, Rice and Westoby 1986).

Rice and Westoby (1986), Rissing (1986) and Westoby et al. (1991) discussed a number of factors that potentially affect differences in the incidence of ant-dispersed seeds among biogeographic regions. Myrmecochory appears to be more prevalent in Australia and South Africa than in other regions. One hypothesis is that smaller plants (characteristic of arid biomes) generally are more likely to be ant-dispersed than are larger plants. A second hypothesis is that the relatively infertile soils of Australia and South Africa preclude nutrient allocation to fruit production, forcing plants to adapt to seed dispersal by ants rather than vertebrates. Finally, Australia and South Africa lack the large harvester ants, e.g., *Pogonomyrmex* spp., *Messor* spp. and *Veromessor* spp., that are common in arid regions of North America and Eurasia. These ants consume relatively large seeds, limiting the value of an elaiosome as a food reward for seed dispersal.

Within biomes, disturbance affects patterns of seed predation and dispersal. Côté et al. (2005) reported that invertebrate predation on black spruce, *Picea mariana*, seeds was highest in recently burned sites, compared to undisturbed sites. On the other hand, Farwig et al. (2006) found that vertebrate frugivore abundances and dispersal of *Prunus africana* seeds were 1.5 times higher in disturbed areas than in forest in western Kenya.

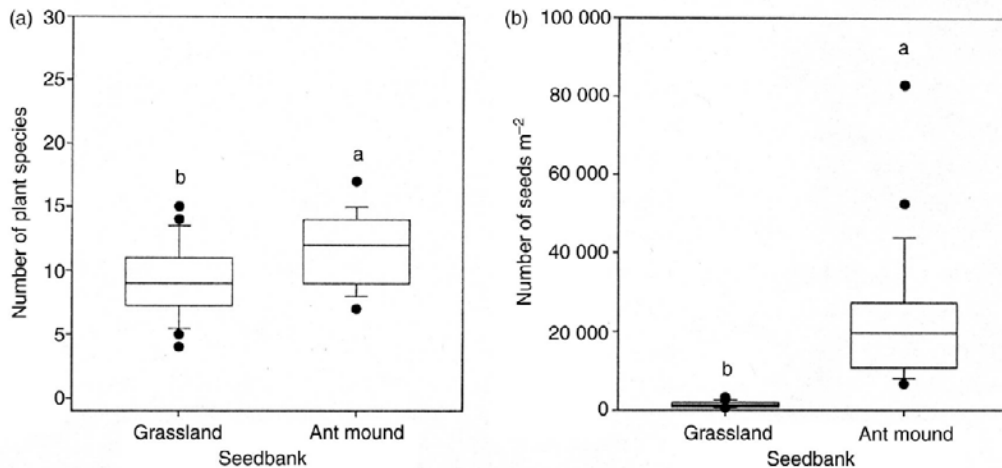
#### IV. EFFECTS OF SEED PREDATION AND DISPERSAL

Seed predators and dispersers influence plant population dynamics and community structure by affecting both seed survival and seedling recruitment. Robertson et al. (1990) reported that pre-dispersal seed predation rates varied widely among mangrove species at study sites in northeastern Australia. Three species (*Ceriops australis*, *Ceriops tagal* and *Rhizophora apiculata*) had fewer than 10% of seeds damaged by insects, whereas six species (*Avicennia marina*, *Bruguiera gymnorrhiza*, *Bruguiera parviflora*, *Heritiera littoralis*, *Xylocarpus australasicus* and *Xylocarpus granatum*) consistently had more than 40% of seeds damaged. These mangrove species also showed variation in more than survival and growth rates (height and diameter) of seedlings from insect-damaged seeds. Ehrlén (1996) reported a significant positive correlation between the change in population growth rate and the reproductive value of seeds, as reduced by seed predation, indicating that survival of seeds and seedlings is the most important aspect of seed predator effects on plant population growth.

Post-dispersal seed predators similarly affect the survival and growth of seeds and seedlings. Côté et al. (2005) suggested that higher predation on black spruce seeds at recently burned sites may delay spruce regeneration on these sites. Seeds selected for storage in ant nests or refuse piles often show increased survival and seedling growth, relative to seeds in control sites (A. Andersen 1988, Culver and Beattie 1980, L. Hughes 1990, Rising 1986). Enhanced seedling growth on ant nests may reflect the higher nutrient concentrations (A. Andersen 1988, Culver and Beattie 1983, Herzog et al. 1976, D. Wagner 1997, D. Wagner et al. 1997, but see Rice and Westoby 1986) or greater water-holding capacity (Jonkman 1978, D. Wagner 1997) of ant nests.

The composition and seed preferences of the frugivore-granivore community affects plant community development (O. Lewis and Gripenberg 2008, M. Schütz et al. 2008). M. Schütz et al. (2008) found that ants, *Formica exsecta*, altered vegetation structure around nests in alpine grasslands. Mound seed banks contained 15 times more seeds, 8 times more seeds of myrmecochorous plant species, and higher species richness than did samples from surrounding grassland. However, graminoids dominated the edges of nest mounds, whereas legumes, shrubs and myrmecochorous species dominated transect points at increasing distance from mound edges (Fig. 13.11). R. Inouye et al. (1980) reported that exclusion of granivorous rodents or ants altered densities and community composition of annual plant species (Table 13.1). Rodents preyed selectively on large-seeded species (e.g., *Erodium* spp. and *Lotus humistratus*). In plots from which rodents were excluded, these species increased to dominate vegetative biomass and replace small-seeded plant species, especially *Euphorbia polycarpa*. Ants preyed most intensively on the most abundant plant species (*Filago californica*). When ants were excluded, this small-seeded composite became numerically dominant and reduced species diversity.

Many plant species have become dependent on animal mutualists for seed-dispersal. Seed and seedling survival for some species depends on distance from parent plants, under which seed predation may be concentrated (O'Dowd and Hay 1980, Schupp 1988). As found by Powell and Powell (1987) and Steffan-Dewenter and Tschamntke (1999) for



**FIG. 13.11** Seed bank composition in soil samples from *Formica exsecta* mounds and surrounding alpine grassland in Switzerland. Box plots indicate median, 25<sup>th</sup> and 75<sup>th</sup> percentiles, black lines are 10<sup>th</sup> and 90<sup>th</sup> percentiles, and filled circles are all values below 10<sup>th</sup> and above 90<sup>th</sup> percentiles. Different letters indicate significant differences ( $P < 0.05$ ). From M. Schütz et al. (2008) with permission from the authors and John Wiley & Sons.

pollinators (see above), decline in abundance of seed dispersal agents may threaten persistence of some plant species.

Plant species that are adapted for dispersal by vertebrates often have hardened seed coats to survive gut passage and may require scarification during passage through the digestive systems before germination is possible. Temple (1977) noted the coincidence between the age (300–400 years) of the last naturally-regenerated tambalacoque trees, *Sideroxylon sessiliflorum* (= *Calvaria major*), and the disappearance of the dodo in 1680 on the South Pacific island of Mauritius. When *S. sessiliflorum* seeds were force-fed to turkeys (approximately the size of the dodo), the seed coats were sufficiently abraded during gut passage to permit germination, demonstrating a potential role of the dodo in dispersal and survival of this once dominant tree. Although the primacy of the dodo's role in *S. sessiliflorum* survival has been challenged (e.g., Witmer and Cheke 1991), it appears that *S. sessiliflorum* and other plant species have suffered from disappearance of seed-dispersing animals from Mauritius.

Janzen and Martin (1982) suggested that a number of Neotropical plants may show reduced seed dispersal as a result of the Pleistocene extinction of the large mammalian fauna that likely fed on their fruits and dispersed seeds. Many large-fruited species experience high seed mortality in fruits rotting under trees in the absence of effective dispersal (Asquith et al. 1999, Janzen and Martin 1982, Oliveira et al. 1995). Disappearance of native ant seed dispersers as a result of habitat fragmentation or competition from invasive ant species (e.g., A. Suarez et al. 1998) similarly may threaten the survival of ant-dispersed plant species. On the other hand, seed dispersers have been shown to facilitate the spread of some exotic plant species (J.M.B. Smith 1989).

The effects of seed predation and dispersal on nutrient cycling or other ecosystem processes have not been studied. However, these organisms affect the movement of nutrients in fruits and seeds. By dispersing fruits and seeds, frugivores, in particular, remove the large energy and nutrient pools in fruits from under parent trees and distribute these over

**TABLE 13.1** Effects of removal of ants, rodents, or both on densities of certain annual plant species, all plants, plant biomass and two measures of species diversity. Values given are ratios of treatment to control (+ Rodents + Ants) means. Numbers in parentheses are mean values for unthinned plots except for plant biomass and the two measures of diversity, which are for control plots. Statistical analysis was by ANOVA;

	+Rodents +Ants	+Rodents -Ants	-Rodents +Ants	-Rodents -Ants	Effects of removal of		
					Rodents	Ants	
<b>Initial Census 29 January 1977</b>							
1. Large plants	1.00 (35.8)	0.98	2.08	2.35	increase**	NS	
2. Small plants	1.00 (292.5)	3.30	3.32	3.17	NS	increase**	
<b>Final Census 2 April 1977</b>							
3. <i>Erodium cicutarium</i> (seed mass = 1.6 mg)	1.00 (1.8)	1.83	7.03	16.11	increase**	NS	
4. <i>E. texanum</i> (seed mass = 1.6 mg)	1.00 (0.6)	0.88	2.07	0.78	increase*	NS	
5. <i>Euphorbia polycarpa</i> (seed mass = 0.2 mg)	1.00 (0.6)	2.00	0.14	0.29	decrease*	NS	
6. <i>Filago californica</i> (seed mass = 0.04 mg)	1.00 (142.1)	1.90	1.43	2.59	NS	increase*	
7. <i>Lotus humistratus</i> (seed mass = 1.5 mg)	1.00 (11.4)	1.14	2.43	5.22	increase**	NS	
8. All plants	1.00 (209.6)	1.35	1.34	1.94	increase*	increase**	
9. Dry mass (all species)	1.00 (5.8)	1.07	2.09	2.17	increase**	NS	
10. Species diversity (H')	1.00 (2.78)	0.73	0.99	0.89	NS	decrease*	
11. Species evenness (E)	1.00 (0.53)	0.77	1.99	1.04	NS	decrease*	

\*=significant at  $P < 0.05$  ;

\*\*=significant at  $P < 0.01$

NS = not significant.

Reproduced from R. Inouye et al. (1980) with permission from the Ecological Society of America.

a large area. Furthermore, as described for herbivores, seed predators and dispersers affect the spatial distribution of various plant species that differentially control nutrient fluxes.

## V. SUMMARY

Insects are the major agents of pollination, seed predation or seed dispersal in many ecosystems. Although few studies have evaluated the effects of pollinators, seed predators and seed dispersers on ecosystem processes, these organisms often are critical to seedling recruitment and vegetation dynamics that affect other ecosystem processes.

Pollination is an important means of increasing genetic heterogeneity and improving plant fitness. Pollination can be accomplished by abiotic (wind) or biotic (insects, birds and bats) agents. Wind pollination is inefficient but sufficiently effective for species that dominate temperate ecosystems. However, animal agents increase pollination efficiency for more isolated plants and are critical to the survival of many plant species that typically occur as widely scattered individuals, especially in deserts and tropical forests. Pollinator functional groups can be distinguished on the basis of their degree of specialization on particular floral resources.

Seed predators often consume the entire reproductive effort of host plants. Pre-dispersal seed predators typically focus on concentrated seed resources on the parent plants, whereas post-dispersal seed predators must locate more scattered seed resources on the ground. Insects are more important pre-dispersal seed predators, but vertebrates are more important as post-dispersal seed predators in most ecosystems.

Seed dispersal is critical to plant species survival, both because new habitats can be colonized and because seed relocation often improves seed and seedling survival. Seeds can be dispersed by abiotic (wind and water) or biotic (insect and vertebrate) agents. Animals can increase dispersal efficiency by moving seeds to more suitable germination sites, especially if seeds are buried. Ants, in particular, can increase seed survival and seedling growth by relocating seeds to nests, where seeds are protected from further predation, from suboptimal surface conditions, and from competition with parent plants. Ant nests also may provide more suitable soil conditions for germination and growth. Some seeds require scarification of hard seed coats and must pass through vertebrate digestive systems before germination can occur.

Both pollination and seed dispersal affect plant population and community dynamics. Differential pollination, seed predation and seed dispersal efficiencies among plant species affect seedling recruitment and growth. Survival of some plant species depends on sufficient abundance of pollinators and/or seed dispersers. However, research should address the extent to which pollinators, seed predators and seed dispersers affect ecosystem processes.

# Decomposition and Pedogenesis

## I. Types and Patterns of Detritivory and Burrowing

- A. Detritivore and Burrower Functional Groups
- B. Measurement of Detritivory, Burrowing and Decomposition Rates
- C. Spatial and Temporal Patterns in Processing of Detritus and Soil

## II. Effects of Detritivory and Burrowing

- A. Decomposition and Mineralization
- B. Soil Structure, Fertility and Infiltration
- C. Primary Production and Vegetation Dynamics

## III. Summary

### Dung beetles and dung management in Australia

Detritivores tend to be particularly inconspicuous, small and concealed in soil and litter. However, they play a critical role in the decomposition of plant litter, carrion and dung and the release of nutrients for reuse by the community. Their importance to decomposition, as well as the intricacy of underlying community interactions, is demonstrated by efforts to manage dung accumulation in Australia following the introduction of cattle.

Dung beetles are instrumental in burying vertebrate dung within a few days and contributing to its decomposition. Individual species are relatively specific with regard to substrate conditions and host range of colonized dung (A. Davis 1996). When cattle were introduced to Australia, their dung accumulated in pastures, because there were no specialized dung beetles to consume it. Native dung beetles prefer the relatively dry, pelleted feces of marsupials and were effective in shredding and burying cattle dung only for a few weeks in spring and autumn (Tyndale-Biscoe 1994). Ferrar (1975) reported that experimentally marked cattle dung survived at least three months and sometimes more than a year. Dung accumulation smothered pasture vegetation cover and increased reproductive habitat for two hematophagous flies, the buffalo fly, *Haematobia irritans exigua*, and the bush fly, *Musca vetustissima*, which became serious pests of cattle and humans (Ferrar 1975, Tyndale-Biscoe and Vogt 1996).

Beginning in 1967, a number of African dung beetles were introduced into Australia to accelerate dung disintegration and nutrient turnover and to manage fly populations (R. Hughes et al. 1978). Initial introductions resulted in substantially increased dung disintegration and burial, from  $< 7\% \text{ wk}^{-1}$  at sites with only one exotic species to 30% at sites with five exotic species, but fluctuated from 0 to 70% depending on beetle abundance (Tyndale-Biscoe 1994). Suppression

(Cont.)

of fly reproduction occurred primarily through dung disturbance (R. Hughes et al. 1978), but the first exotic species were most active during the warm monsoon season and relatively ineffective earlier when bush flies first appear (A. Davis 1996, Tyndale-Biscoe and Vogt 1996). Subsequent research identified additional dung beetle species that could be active earlier (Ridsdill-Smith and Kirk 1985) and demonstrated the importance of phoretic mites, e.g., native *Macrocheles glaber* and exotic *Macrocheles peregrinus*, which prey on fly larvae in dung pads (J. Roth et al. 1988). Although we do not know all the consequences of these introductions, the mean abundances of native dung beetles have remained similar to their pre-introduction abundances (Tyndale-Biscoe and Vogt 1996). These studies demonstrate that detritivores are capable of dramatically reducing accumulation of organic litter and influencing community dynamics.

## INTRODUCTION

DECOMPOSITION IS THE BREAKDOWN OF DEAD ORGANIC MATTER THAT eventually results in release of CO<sub>2</sub>, other organic trace gases, water, mineral nutrients, and energy. Pedogenesis (soil development) largely reflects the activities of animals, including those involved in decomposition, that mix organic matter with mineral soil. These two processes contribute greatly to the capacity of a site to support primary production. Accumulated organic litter represents a major pool of energy, water and nutrients in many ecosystems. Carbon and other nutrients released through decomposition can be acquired by plants or microbes or returned to abiotic pools (see Chapter 11). Incorporation of decay-resistant organic matter and nutrients into soil increases its fertility, aeration and water-holding capacity. Release of CO<sub>2</sub>, CH<sub>4</sub> and other trace gases affects both atmospheric conditions and global climate.

Decomposition can be categorized into four component processes: **photo-oxidation**, the abiotic catabolism resulting from exposure to solar radiation; **leaching**, the loss of soluble materials as a result of percolation of water through material; **comminution**, the fragmentation of organic litter, largely as a result of detritivory; and **mineralization**, the catabolism of organic molecules by microorganisms. Vossbrinck et al. (1979) found that when arthropods and microbes were excluded, detritus lost only 5% of its mass, due entirely to leaching and/or photo-oxidation. A variety of arthropods are the primary detritivores in most ecosystems. The feeding and burrowing activities of many animals, including ants, termites and other arthropods, redistribute and mix soil and organic material. Burrowing also increases soil porosity, thereby increasing aeration and water-holding capacity.

The effects of arthropod detritivores and burrowers on decomposition and soil development have been the most widely-studied effects of arthropods on ecosystem processes (e.g., Ausmus 1977, Coleman et al. 2004, Crossley 1977, Eldridge 1993, 1994, Seastedt 1984, Swift 1977, Swift et al. 1979, Whitford 2000, Wotton et al. 1998). Arthropod detritivores and burrowers are relatively accessible and can be manipulated for experimental purposes. Their key contributions to decomposition and mineralization of litter (both fine or suspended organic matter and coarse woody debris) and pedogenesis have been demonstrated in virtually all ecosystems. Indeed, some aquatic and glacial ecosystems consist entirely of arthropod detritivores and associated microorganisms feeding on allochthonous detritus (J. Edwards and Sugg 1990, Oertli 1993, J. Wallace et al. 1992). The effects of detritivorous and fossorial species on decomposition and soil mixing depend on the size of the organism, its food source, type and rate of detritivory, the volume of displaced litter or soil, and type of saprophytic microorganisms that are inoculated into

litter. Although most studies have addressed the effects of detritivores and burrowers on soil processes, some have documented their effects on primary production.

## I. TYPES AND PATTERNS OF DETRITIVORY AND BURROWING

### A. Detritivore and Burrower Functional Groups

Functional groups of detritivorous and fossorial arthropods have been distinguished on the basis of their principal food source, mode of feeding and microhabitat preferences (e.g., J.C. Moore et al. 1988, J. Wallace et al. 1992). For example, functional groups can be distinguished on the basis of seasonal occurrence, habitats, and substrates (e.g., terrestrial vs. aquatic, animal vs. plant detritus, foliage vs. wood, arboreal vs. fossorial), or particular stages in the decomposition process (N. Anderson et al. 1984, C. Hawkins and MacMahon 1989, Schowalter and Sabin 1991, Schowalter et al. 1998, Seastedt 1984, Siepel and de Ruiter-Dijkman 1993, Tantawi et al. 1996, Tullis and Goff 1987, J. Wallace et al. 1992, Winchester 1997, Zhong and Schowalter 1989).

General functional groupings for detritivores are based on their effect on decomposition processes. **Coarse** and **fine comminuters** are instrumental in the fragmentation of litter material. Major taxa in terrestrial ecosystems include millipedes, earthworms, termites, and beetles (coarse) and mites, collembolans and various other small arthropods (fine). Many species are primarily **fungivores** or **bacteriovores** that fragment substrates while feeding on the surface microflora. Many fungivores and bacteriovores, including nematodes and protozoa, as well as arthropods, feed exclusively on microflora and affect the abundance and distribution of these decomposers (e.g., Santos et al. 1981). A number of species, including dung beetles, millipedes and termites, are **coprophages**, either feeding on feces of larger species or reingesting their own feces following microbial decay and enrichment (Cambefort 1991, Coe 1977, Dangerfield 1994, Holter 1979, Kohlmann 1991, McBrayer 1975).

In aquatic ecosystems **scrapers** (including mayflies, caddisflies, chironomid midges, and elmids beetles), that graze or scrape microflora from mineral and organic substrates, and **shredders** (including stoneflies, caddisflies, crane fly larvae, crayfish and shrimp), that chew or gouge large pieces of decomposing material, represent coarse comminuters; **gatherers** (including stoneflies, mayflies and copepods), that feed on fine particles of decomposing organic material deposited in streams, and **filterers** (mayflies, caddisflies, and black flies), that have specialized structures for sieving fine suspended organic material, represent fine comminuters (Cummins 1973, J. Wallace and Webster 1996, J. Wallace et al. 1992).

**Xylophages** are a diverse group of detritivores which are specialized to excavate and fragment woody litter. Aquatic xylophages include crane flies and elmids beetles. Terrestrial taxa include curculionid, buprestid, cerambycid and lyctid beetles, siricid wasps, carpenter ants, *Camponotus* spp., and termites (Fig. 14.1), with different species often specialized on particular wood species, sizes or stages of decay (see Chapter 10). Most of these species either feed on fungal-colonized wood or support mutualistic, internal or external fungi or bacteria that digest cellulose and enhance the nutritional quality of wood (e.g., Breznak and Brune 1994, Siepel and de Ruiter-Dijkman 1993, see Chapter 8).

**Carrion feeders** represent another specialized group that breaks down animal carcasses. Major taxa include staphylinid, sylphid, scarabaeid, and dermestid beetles, callophorid, muscid and sarcophagid flies, and various ants. Different species typically specialize on particular stages of decay (Figs. 10.4 and 10.5) and on particular animal groups, e.g., reptiles vs. mammals (E. Watson and Carlton 2003).





**FIG. 14.1** *Melanophila* sp. (Coleoptera: Buprestidae) larva in mine in phloem of recently killed Douglas-fir tree in western Oregon. The entire phloem volume of this tree has been fragmented and converted to frass packed behind mining larvae of this species, demonstrating detritivore capacity to reduce detrital biomass.

An important consequence of litter fragmentation by arthropods is an increased surface area for microbial colonization and decomposition. Microbes also are redistributed, either passively through transport of microbes acquired during feeding or dispersal or actively through inoculation of mutualistic associates, to fresh surfaces during feeding.

Many detritivores redistribute large amounts of soil or detritus during their foraging or feeding activities (e.g., Kohlmann 1991). However, non-detritivores also contribute to mixing of soil and organic matter. Fossorial functional groups can be distinguished on the basis of their food source, and mechanism and volume of soil/detrital mixing. **Subterranean nesters** burrow primarily for shelter. Vertebrates, e.g., squirrels, woodrats and coyotes, and many invertebrates, including crickets and solitary wasps, excavate tunnels of various sizes, typically depositing soil on the surface and introducing some organic detritus into nests. **Gatherers**, primarily social insects, actively concentrate organic substrates in colonies. Ants and termites redistribute large amounts of soil and organic matter during construction of extensive subterranean, surficial or arboreal nests (J. Anderson

1988, Haines 1978). Subterranean species concentrate organic matter in nests that have been excavated in soil, but many species bring fine soil particles to the surface and mix soil with organic matter in arboreal nests or foraging tunnels. These insects can affect a large volume of substrate (up to 1000 m<sup>3</sup>), especially as a result of restructuring and lateral movement of the colony (L. Hughes 1990, J. Moser 1963, Whitford et al. 1976). **Fossorial feeders**, such as gophers, moles, earthworms, mole crickets (Gryllotalpidae), and benthic invertebrates feed on subsurface resources (plant, animal or detrital substrates) as they burrow, constantly mixing mineral substrate and organic material in their wake.

## B. Measurement of Detritivory, Burrowing and Decomposition Rates

Evaluation of the effects of detritivory and burrowing on decomposition and soil mixing requires appropriate methods for measuring the rates of these processes. Several methods have been used to measure rates of leaf litter decomposition and soil mixing (Coleman et al. 2004). Measurement of wood decomposition presents special problems, including the long time-frame involved and the logistical difficulties of experimental placement and manipulation of large, heavy materials. Decomposition of large woody debris represents one of the longest ecological processes, often spanning centuries (Harmon et al. 1986). This process traditionally was studied by comparing mass of wood of estimated age to the mass that was expected for the estimated original volume, based on the particular tree species. However, decomposition of some wood components begins only after lag times of up to several years, decomposition of standing tree boles is much slower than fallen boles, and differences in chemistry and volume between bark and wood components affect overall decay rates (Harmon et al. 1986, Schowalter et al. 1998).

Detritivory can be measured by providing experimental substrates and measuring colonization and consumption rates. K. Johnson and Whitford (1975) measured the rate of termite feeding on an artificial carbohydrate source and natural substrates in a desert ecosystem. Edmonds and Eglitis (1989) and Zhong and Schowalter (1989) measured the rate of wood-borer colonization and excavation in freshly-cut tree boles. Dissection of wood samples is necessary for measurement of excavated volume for small insects. Radiography can be used to measure larger volumes, e.g., termite galleries.

Detritivory often has been estimated by multiplying the per capita feeding rate for each functional group by its abundance (N. Anderson et al. 1984, Cárcamo et al. 2000, Crossley et al. 1995, Dangerfield 1994). Cárcamo et al. (2000) estimated the consumption of conifer needle litter by the millipede, *Harpaphe haydeniana*, as about 90 mg g<sup>-1</sup> animal biomass da<sup>-1</sup>, a rate that could account for processing of 36% of annual litterfall. Laboratory conditions, however, might not represent the choices of substrates available under field conditions. For example, Dangerfield (1994) noted that laboratory studies might encourage coprophagy by millipedes by restricting the variety of available substrates, thereby over-representing this aspect of consumption. Mankowski et al. (1998) used both forced-feeding and choice tests to measure wood consumption by termites when a variety of substrate types was available or restricted.

Radioisotope movement from litter provided early data on decomposition rates (Witkamp 1971). Stable isotopes (e.g., <sup>13</sup>C, <sup>14</sup>C, and <sup>15</sup>N) are becoming widely used to measure fluxes of particular organic fractions (Ågren et al. 1996, Andreux et al. 1990, Horwath et al. 1996, Mayer et al. 1995, Šantrůčková et al. 2000, Spain and Le Feuvre 1997, Wedin et al. 1995). The most widely-used techniques for measuring decomposition rates in

terrestrial and aquatic ecosystems involve measurement of respiration rate, comparison of litterfall and litter standing crop, and measurement of mass loss (J. Anderson and Swift 1983, Bernhard-Reversat 1982, Seastedt 1984, Witkamp 1971, Woods and Raison 1982). These techniques tend to oversimplify representation of the decomposition process and consequently yield biased estimates of decay rate.

Respiration from litter or soil represents the entire heterotrophic community, as well as living roots. Most commonly, a chamber containing sodalime or a solution of NaOH is sealed over litter for a 24 hr period, and CO<sub>2</sub> efflux is measured as the weight gain of sodalime or volume of acid that is neutralized by NaOH (N. Edwards 1982). Comparison of respiration rates between plots with litter present and plots with litter removed provides a more accurate estimate of respiration rates from decomposing litter, but separation of litter from soil is difficult and often arbitrary (J. Anderson and Swift 1983, Woods and Raison 1982). More recently, gas chromatography and infra-red gas analysis (IRGA) have been used to measure CO<sub>2</sub> efflux (Nakadai et al. 1993, Parkinson 1981, Raich et al. 1990).

The ratio of litterfall mass to litter standing crop provides an estimate of the decay constant,  $k$ , when litter standing crop is constant (Olson 1963). A decay rate can be calculated if the rate of change in litter standing crop is known (Woods and Raison 1982). This technique also is limited by the difficulty of separating litter from underlying soil for mass measurement (J. Anderson and Swift 1983, Spain and Le Feuvre 1987, Woods and Raison 1982).

Weight loss of fine litter has been measured using tethered litter, litterbags, and litter boxes. Tethering allows litter to take a natural position in the litterbed and does not restrict detritivore activity or alter microclimate, but is subject to loss of fragmented material and the difficulty in separating litter in late stages of decay from surrounding litter and soil (N. Anderson et al. 1984, Birk 1979, Witkamp and Olson 1963, Woods and Raison 1982).

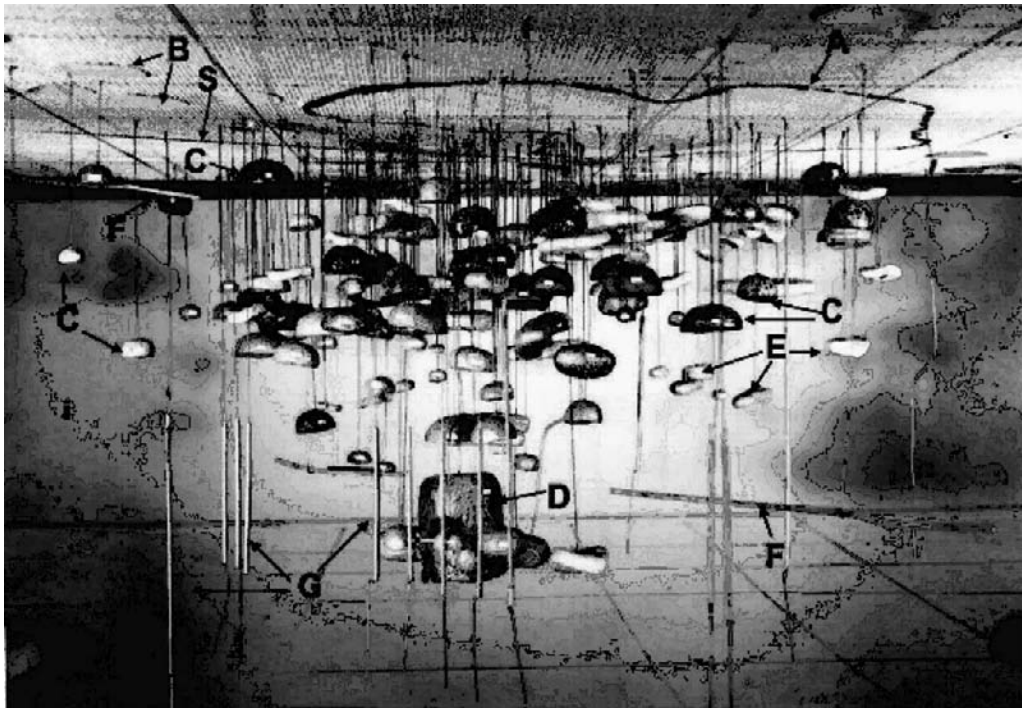
Litterbags provide a convenient means for studying litter decomposition (Crossley and Hoglund 1962, C. Edwards and Heath 1963). They retain selected litter material, and their mesh size can be used to selectively restrict entry by larger functional groups (e.g., C. Edwards and Heath 1963, D. Wise and Schaefer 1994). However, litterbags may alter litter microclimate and restrict detritivore activity, depending on litter conformation and mesh size. Moisture retention between flattened leaves apparently is independent of mesh size. Exclusion of larger detritivores by small mesh sizes has little effect, at least until litter has been preconditioned by microbial colonization (J. Anderson and Swift 1983, Macauley 1975, O'Connell and Manag e 1983, Spain and Le Feuvre 1987, Woods and Raison 1982). Exclusion of predators by small mesh sizes can significantly affect detritivore abundances and decomposition processes (M.D. Hunter et al. 2003). Large woody litter (e.g., tree boles) also can be enclosed in mesh cages for experimental restriction of colonization by xylophagous insects (Harmon et al. 1994, Zhong and Schowalter 1989). The potential interference with decomposition by small mesh sizes has been addressed in some studies by minimizing leaf overlap (and prolonged moisture retention) in larger litterbags, using small mesh on the bottom to retain litter fragments and large mesh on the top to maximize exchange of moisture and detritivores, and measuring decomposition over several years to account for differences due to changing environmental conditions (J. Anderson et al. 1983, Cromack and Monk 1975, Woods and Raison 1982, 1983). Despite their limitations, litterbags have been the simplest and most widely used method for measuring decomposition rates and probably provide reasonably accurate estimates (Seastedt 1984, Spain and Le Feuvre 1987, Woods and Raison 1982).

More recently, litter boxes have been designed to solve some of the problems associated with litterbags. Litter boxes can be inserted into the litter, with the open top providing unrestricted exchange of moisture and detritivores (Seastedt and Crossley 1983), or they can be used as laboratory microcosms to study effects of decomposers (Haimi and Huhta 1990, Huhta et al. 1991). Similar constructions can be incorporated into streams for assessment of detrital decomposition (March et al. 2001).

Abundances of detritivore functional groups can be manipulated directly to some extent by use of microcosms (Setälä and Huhta 1991, Setälä et al. 1996), selective biocides or other exclusion techniques (Crossley and Witkamp 1964, C. Edwards and Heath 1963, González and Seastedt 2001, E. Ingham et al. 1986, Macauley 1975, C. Pringle et al. 1999, Santos and Whitford 1981, Seastedt and Crossley 1983, J. Wallace et al. 1991, Zhong and Schowalter 1989) or by adding or simulating detritivores in new substrates (Barker 2008, González and Seastedt 2001, Progar et al. 2000). Naphthalene and chlordane in terrestrial studies (Crossley and Witkamp 1964, Santos and Whitford 1981, Seastedt and Crossley 1983, Whitford 1986) and methoxychlor or electric fields in aquatic studies (Pringle et al. 1999, J. Wallace et al. 1991) have been used to exclude arthropods. However, E. Ingham (1985) reviewed the use of selective biocides and concluded that none had effects limited to a particular target group, limiting their utility for evaluating effects of individual functional groups. Furthermore, Seastedt (1984) noted that biocides provide a carbon and, in some cases, nitrogen source that may alter the activity or composition of microflora. Mesh sizes of litterbags (see below) can be manipulated to exclude detritivores larger than particular sizes, but this technique often alters litter environment and may reduce fragmentation, regardless of faunal presence (Seastedt 1984).

Few experimental studies have compared effects of manipulated abundances of xylophagous insects on wood decomposition (Edmonds and Eglitis 1989, Progar et al. 2000, Zhong and Schowalter 1989). Some studies have compared species or functional group abundances in wood of estimated age or decay class, but such comparison ignores the effect of initial conditions on subsequent community development and decomposition rate. Prevailing weather conditions, the physical and chemical condition of the wood at the time of plant death, and prior colonization determine the species pools and establishment of potential colonists. Penetration of the bark and transmission by wood-boring insects generally facilitate microbial colonization of subcortical tissues (Ausmus 1977, Dowding 1984, Swift 1977). Käärik (1974) reported that wood previously colonized by mold fungi (Ascomycotina and Fungi Imperfecti) was less suitable for establishment by decay fungi (Basidiomycotina) than was uncolonized wood. Mankowski et al. (1998) reported that wood consumption by termites was affected by wood species and fungal preconditioning. Hence, experiments should be designed to evaluate the effects of species or functional groups on decomposition over long time periods using wood of standard size, composition and condition (e.g., Progar et al. 2000).

Assessing rates of burrowing and mixing of soil and litter is even more problematic. The nest structure of social insects has been revealed by pouring liquid latex, plaster or metal into nest entrances and excavating after solidification (Tschinkel 2004, 2005). Larger or deeper nests require excavation by construction equipment (J. Moser 1963, 2006, Tschinkel 1999, Whitford et al. 1976). Excavation can be extremely labor-intensive. Colonies of the leaf-cutting ant, *Atta texana*, can be 20–30 m in diameter, with as many as 170 chambers and vertical tunnels extending perhaps as deep as 32 m (Fig. 14.2, J. Moser 2006). The difficulty of separating litter from soil, except where fungal gardens are in discrete chambers, limits measurement of mixing. Tunneling through woody litter presents similar



**FIG. 14.2** Model of a Texas leaf-cutter ant, *Atta texana*, colony excavated in northern Louisiana, showing the funnel-shaped structure of the underground nest. A) edge of the excavated surface subsoil, B) feeder holes on the surface, C) fungus garden cavities, showing typical inverted hemispherical shape (black cavities are largely full of fungus), D) central cavity at bottom of nest, E) irregularly-shaped detritus cavities, F) horizontal tunnels, G) vertical tunnels, and S) south end of N-S line across ground surface of nest. From J. Moser (2006) with permission from the Entomological Society of America.

problems. Zhong and Schowalter (1989) dissected decomposing tree boles to assess the volume of wood excavated and/or mixed among bark, wood and fecal substrates.

### C. Spatial and Temporal Patterns in Processing of Detritus and Soil

All, or most, dead organic matter eventually is catabolized to  $\text{CO}_2$ , water and energy, reversing the process by which energy and matter were fixed in primary production. Some materials are decomposed more readily than are others, some processes release carbon primarily as methane, and some carbon enters long-term storage as humus, peat, coal or oil. Moisture, litter quality (especially lignin and nitrogen content) and oxygen supply are primary factors that affect decomposition mechanisms (Aerts 1997, Birk 1979, Cotrufo et al. 1998, Fogel and Cromack 1977, Fonte and Schowalter 2004, González and Seastedt 2001, Kurokawa and Nakashizuka 2008, Meentemeyer 1978, Progar et al. 2000, Seastedt 1984, Tian et al. 1995, Treseder 2008, Whitford et al. 1981). Decomposition rate generally increases with moisture content, but saturation with water inhibits decomposition, because of limited oxygen availability (Progar et al. 2000). Submerged litter is degraded primarily by aquatic gougers and scrapers that slowly fragment and digest consumed organic matter from the surface inward (N. Anderson et al. 1984). The decomposition rate also generally

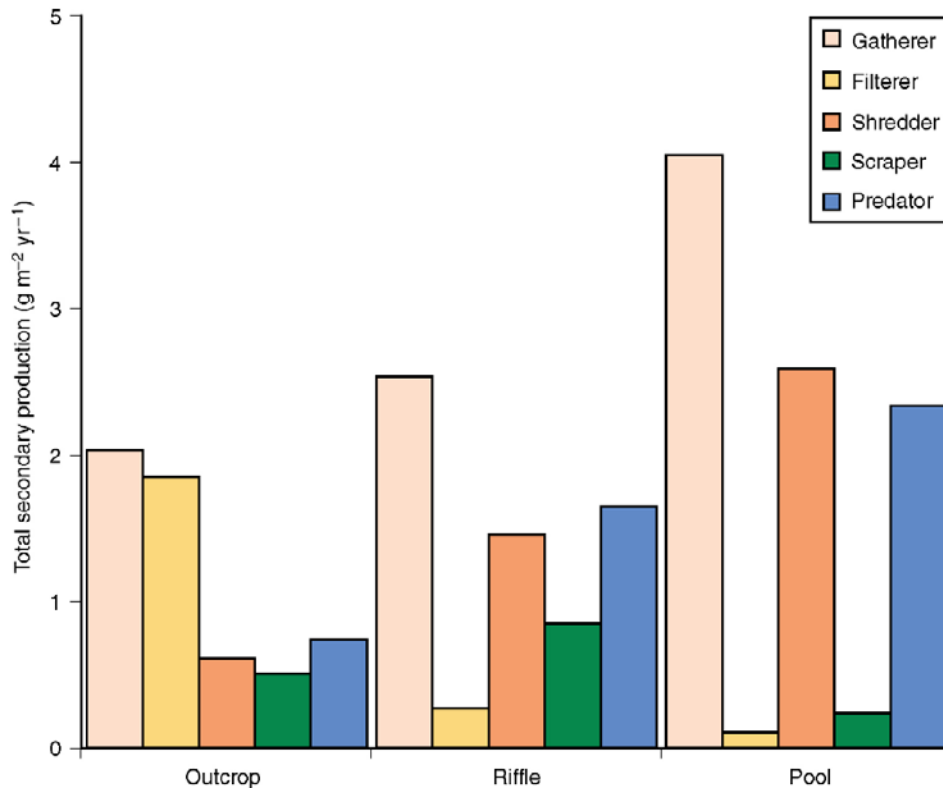
increases with nitrogen content and decreases with lignin content of the litter, but can be inhibited at low C/N ratios (Hobbie 2008, Knorr et al. 2005, Treseder 2008). Animal carion, except for bones, is readily digestible by many organisms and decomposes rapidly (Payne 1965), whereas plant materials, especially those composed largely of lignin and cellulose, can be decomposed only by relatively few species of fungi, bacteria, or protozoa and may require long time periods for complete decomposition (Harmon et al. 1986). Conifer litter tends to decompose more slowly than does angiosperm litter, because of its low nitrogen and high lignin content. Low soil or litter pH inhibits decomposition.

Decomposition processes differ among ecosystem types. Physical factors may predominate in xeric ecosystems, where decomposition of exposed litter reflects the catabolic effects of ultraviolet light. Decomposition resulting from biological processes is favored by warm, moist conditions. Hence, it is most rapid in wet tropical ecosystems, where litter disappears quickly, and slowest in desert, tundra and boreal ecosystems because of dry or cold conditions. González and Seastedt (2001) and Heneghan et al. (1999) compared decomposition of a common litter species between tropical and temperate ecosystems and demonstrated that the rate was consistently higher in the tropical wet forests. Nevertheless, decomposition may continue underground, or under snow in tundra and boreal regions, where temperature and moisture are adequate (e.g., Santos et al. 1981). As noted above, decomposition rates may be lower in aquatic ecosystems as a result of saturation and limited oxygen supply. Low decomposition rates generally result in the accumulation of large standing crops of woody and fine litter.

Different groups of detritivores and decomposers dominate different ecosystems. For example, shredders and gatherers were more abundant in pools and headwater streams, characterized by substantial inputs of largely unfragmented organic matter, whereas filter-feeders were more abundant in high gradient sections or higher-order streams (e.g., the Little Tennessee River), characterized by highly-fragmented, suspended organic matter (Fig. 14.3). Fungi and associated fungivores, e.g., oribatid mites and Collembola, are more prevalent in forests, whereas bacteria, bacteriovores, especially prostigmatid mites and Collembola, and earthworms are more prevalent in grasslands (Seastedt 2000). Termites are the most important detritivores in arid and semi-arid ecosystems and may largely control decomposition processes in forests and grasslands (K.E. Lee and Butler 1977, Whitford 1986). J. Jones (1989, 1990) reported that termites in dry tropical ecosystems in Africa so thoroughly decomposed organic matter that little or no carbon was incorporated into the soil. Wood-boring insects only occur in ecosystems with woody litter accumulation, and are vulnerable to loss of this resource in managed forests (Grove 2002). Dung feeders are important in ecosystems where vertebrate herbivores are abundant (Coe 1977, Holter 1979).

The relative contributions of physical and biological factors to pedogenesis vary among ecosystems. Erosion and earth movements (e.g., soil creep and landslides) mix soil and litter in ecosystems that have steep topography or high wind or raindrop impact on surface material. Burrowing animals are common in ecosystems with loose substrates which are suitable for excavation. Grasslands and forests on sandy or loamy soils support the highest diversity and abundances of burrowers. Ants can excavate nests through rocky, or other, substrates that would preclude burrowing by larger or softer-bodied animals and are the dominant burrowers in many ecosystems.

Distinct temporal patterns in decomposition rates often reflect either the preconditioning requirements for further degradation or the inhibition or facilitation of new colonizers by established groups. For example, leaching of toxic plant chemicals may be necessary



**FIG. 14.3** Annual secondary production for aquatic functional groups in bedrock outcrop, riffle and pool habitats of upper Ball Creek, North Carolina, during July 1983–June 1984. Data from Hurny and Wallace (1987).

before many groups are able to colonize litter (Barz and Weltring 1985). M. Hulme and Shields (1970) and Käärik (1974) reported that wood decay is inhibited by competition for labile carbohydrates, necessary for early growth of decay fungi, by non-decay fungi. On the other hand, Blanchette and Shaw (1978) found that decay fungus growth in wood with bacteria and yeasts was twice that in wood without bacteria and yeasts, presumably because bacteria and yeasts provide fixed nitrogen, vitamins and other nutrients while exploiting carbohydrates from lignocellulose degradation. Microbes typically require bark penetration, and often inoculation, by insects in order to colonize woody litter. Many saprophagous arthropods require some preconditioning of litter by bacteria, fungi, or other arthropods prior to feeding. Small comminutors typically feed on fragments or feces left by larger comminutors (O'Connell and Menagé 1983). Shredders in streams convert coarse particulate organic matter (CPOM) to fine particulate organic matter (FPOM) that can be acquired by filterers (J. Wallace and Webster 1996, J. Wallace et al. 1991). Santos and Whitford (1981) reported that a consistent succession of microarthropods was related to the percentage of organic matter lost.

Decomposition often begins long before detritus reaches the ground. Considerable detrital accumulation occurs in forest canopies (Coxson and Nadkarni 1995, Lindo and Winchester 2007, Paoletti et al. 1991). Processes of decomposition and pedogenesis in these suspended sediments are poorly known. Paoletti et al. (1991) reported that suspended

soils associated with bromeliads in a Venezuelan cloud forest had higher concentrations of organic matter, nitrogen, calcium and magnesium and higher densities (based on bulk density of soil) of macro- and microinvertebrates than did forest floor soils. Lindo and Winchester (2007) found that suspended soils in old-growth western redcedar, *Thuja plicata*, canopies in western Canada had higher concentrations of nitrogen, phosphorus and potassium, but lower moisture content and oribatid mite abundance and diversity, compared to forest floor soils. In both studies, rates of litter decomposition, as measured in litterbags, were similar between the canopy and forest floor. Oribatid mites and Collembola are the most abundant detritivores in temperate and tropical forest canopies (Paoletti et al. 1991, Schowalter and Ganio 1998, D. Walter and O'Dowd 1995, Winchester 1997) and many are canopy specialists that do not occur on the forest floor (Lindo and Winchester 2007, Winchester et al. 1999).

Decomposition is an easily modeled process. Typically, an initial period of leaching or microbial oxidation of simple organic molecules results in a short-term, rapid loss of mass, which is followed by a longer-term, slower decay of recalcitrant compounds. Decomposition of foliage litter has been expressed as a single- or double-component negative exponential model (Olson 1963):

$$N_t = S_0 e^{-k_t t} + L_0 e^{-k_l t} \quad (14.1)$$

Where  $N_t$  is mass at time  $t$ ,  $S_0$  and  $L_0$  are masses in short- and long-term components, respectively, and  $k$ 's are the respective decay constants. The short-term rate of decay reflects the mass of labile organic molecules, and the long-term rate of decay reflects lignin content and actual evapotranspiration (AET) rate, based on temperature and moisture conditions (Meentemeyer 1978, Seastedt 1984). Long-term decay rates for foliage litter range from  $-0.14 \text{ yr}^{-1}$  to  $-1.4 \text{ yr}^{-1}$ , depending on nutritional value for decomposers (Table 14.1) (Laskowski et al. 1995, Seastedt 1984, Schowalter et al. 1991). Decay rates for wood range from  $-0.004 \text{ yr}^{-1}$  to  $-0.5 \text{ yr}^{-1}$  (Harmon et al. 1986). Schowalter et al. (1998) monitored the decomposition of freshly-cut oak, *Quercus* spp., logs over a 5-yr period and found that

**TABLE 14.1** Percent of leaf litter decomposition attributable to invertebrate detritivores.

Leaf species	$k_t$	$k_{NA}$	$k_f$	percent due to fauna
Dogwood	-0.00248	-0.00089	-0.00159 <sup>a</sup>	64 <sup>b</sup>
Sweetgum	-0.00175	-0.00050	-0.00125	71
Tulip poplar	-0.00229	-0.00113	-0.00116	51
Red maple	-0.00125	-0.00069	-0.00056	45
Water oak	-0.00174	-0.00037	-0.00137	79
White oak	-0.00216	-0.00076	-0.00140	65

<sup>a</sup> Loss rate attributable to detritivores ( $k_f$ ) was calculated as total decay rate ( $k_t$ ) minus rate with naphthalene added ( $k_{NA}$ )

<sup>b</sup> Percent due to fauna was calculated as  $k_f/k_t$ .

Modified from Coleman et al., (2004) with permission from Elsevier and the authors.



a 3-component exponential model was necessary to account for differential decay rates among bark and wood tissues. An initial decay rate of  $-0.12 \text{ yr}^{-1}$  during the first year reflected primarily the rapid loss of the nutritious inner bark (phloem), which had largely disappeared by the end of the second year as a result of rapid exploitation by insects and fungi. An intermediate decay rate of  $-0.06 \text{ yr}^{-1}$  for years 2–5 reflected the slower decay rate for sapwood and outer bark, and a long-term decay rate of  $-0.012 \text{ yr}^{-1}$  was predicted, based on the slow decomposition of heartwood.

Decomposition often is not constant but shows seasonal peaks and annual variation that reflect periods of suitable temperature and moisture for decomposers. Patterns of nutrient mineralization from litter reflect periods of storage and loss, depending on the activities of various functional groups. For example, Schowalter and Sabin (1991) reported that the nitrogen and calcium content of decomposing Douglas-fir, *Pseudotsuga menziesii*, needle litter, in litterbags, in western Oregon peaked in spring each year, when microarthropod abundances were lowest, and declined during winter, when microarthropod abundances were highest. High rates of comminution by microarthropods and decay by microorganisms during the wet winters probably contributed to the release of nutrients from litter, whereas reduced comminution and decay during dry springs and summers led to nutrient immobilization in microbial biomass. Similarly, fluctuating concentrations of nutrients in decomposing oak wood over time probably reflect patterns of colonization and nutrient mobilization (Schowalter et al. 1998).

## II. EFFECTS OF DETRITIVORY AND BURROWING

Arthropod detritivores and burrowers affect decomposition, carbon flux, biogeochemical cycling, pedogenesis, and primary production directly and indirectly. The best known effects are on decomposition and mineralization (Seastedt 1984, Coleman et al. 2004). However, some detritivorous and fossorial arthropods are capable of significantly affecting ecosystem structure, including the spatial distribution of carbon and nutrients, as well as ecosystem capacity to store and release nutrients and pollutants, making them true ecosystem engineers (Jouquet et al. 2006).

### A. Decomposition and Mineralization

An extensive literature has addressed the effects of detritivores on decomposition and mineralization rates (Coleman et al. 2004, Hättenschwiler and Gasser 2005). Generally, the effect of arthropods on the decay rate of litter can be calculated by subtracting the decay rate when arthropods are excluded from the decay rate when arthropods are present (Table 14.1). Detritivores affect decomposition and mineralization processes, including fluxes of carbon as  $\text{CO}_2$  or  $\text{CH}_4$ , by fragmenting litter and by affecting rates of microbial catabolism of organic molecules. The magnitude of these effects depends on the degree to which feeding increases the surface area of litter and inoculates or reduces microbial biomass.

#### 1. Comminution

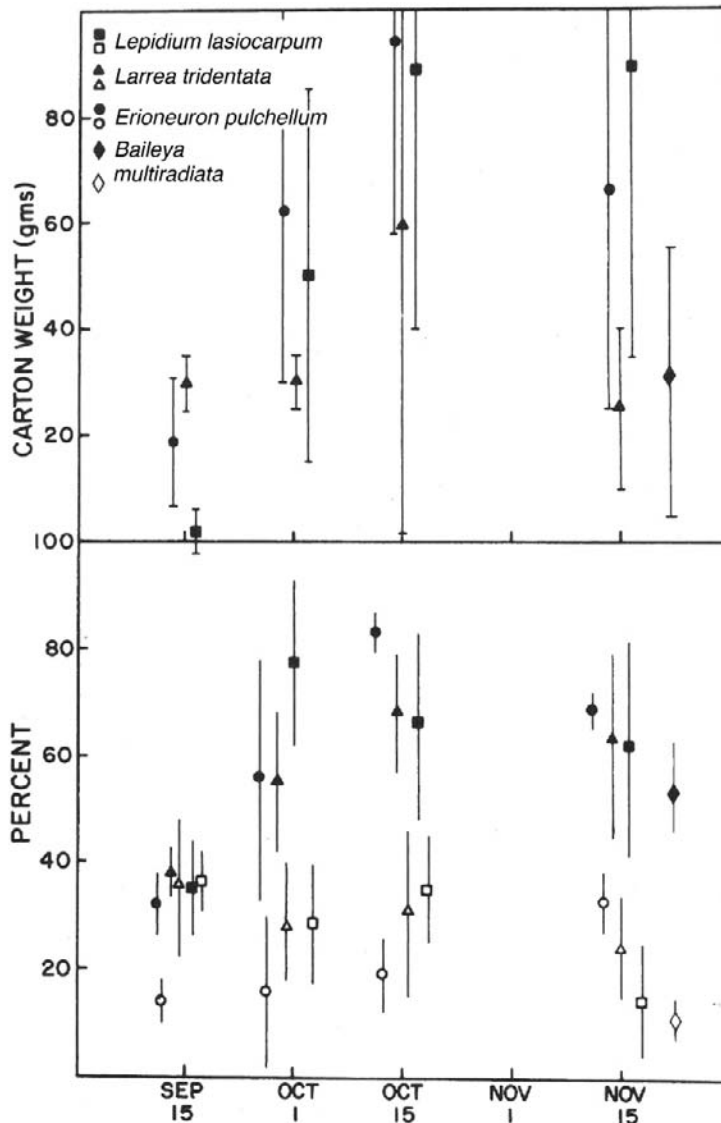
Large comminuters are responsible for the fragmentation of large detrital materials into finer particles that can be processed by fine comminuters and saprophytic microorganisms. Cuffney et al. (1990) and J. Wallace et al. (1991) reported that a 70% reduction in abundance of shredders from a small headwater stream in North Carolina, U.S.,

reduced leaf litter decay rates by 25–28%, and the export of fine particulate organic matter by 56%. As a result, unprocessed leaf litter accumulated (J. Wallace et al. 1995). D. Wise and Schaefer (1994) found that excluding macroarthropods and earthworms from leaf litter of selected plant species in a beech forest reduced decay rates by 36–50% for all litter types except fresh beech litter. When all detritivores were excluded, the comparable reduction in decay rate was 36–93%, indicating the prominent role of large comminuters in decomposition. Tian et al. (1995) manipulated the abundances of millipedes and earthworms in tropical agricultural ecosystems. They found that millipedes alone accounted for 10–65% of total decay over a 10 wk period. Earthworms did not affect decay significantly by themselves, but earthworms and millipedes combined significantly accounted for 11–72% of total decay. Haimi and Huhta (1990) demonstrated that earthworms significantly increased mass loss of litter by 13–41%. N. Anderson et al. (1984) noted that aquatic xylophagous tipulid larvae fragmented >90% of decayed red alder, *Alnus rubra*, wood in a 1 yr period.

Termites have received considerable attention because of their substantial ecological and economic importance in forest, grassland and desert ecosystems. Based on laboratory feeding rates, K.E. Lee and Butler (1977) estimated the rate of wood consumption by termites in dry sclerophyll forest in South Australia. They reported that wood consumption by termites was equivalent to about 25% of annual woody litter increment and 5% of total annual litterfall. Based on termite exclusion plots, Whitford et al. (1982) reported that termites consumed up to 40% of surficial leaf litter in a warm desert ecosystem in the southwestern U.S. (Fig. 14.4). Overall, termites in this ecosystem consumed at least 50% of the estimated annual litterfall (K. Johnson and Whitford 1975, Silva et al. 1985). N.M. Collins (1981) reported that termites in tropical savannas in West Africa consumed 60% of annual wood-fall and 3% of annual leaf fall (24% of total litter production), but fire removed 0.2% of annual wood-fall and 49% of annual leaf fall (31% of total litter production). In that study, fungus-feeding Macrotermitinae were responsible for 95% of the litter removed by termites. Termites apparently consume virtually all litter in tropical savannas in East Africa (J. Jones 1989, 1990). Termites consume a lower proportion of annual litter inputs in more mesic ecosystems. N.M. Collins (1983) reported that termites consumed about 16% of annual litter production in a Malaysian rain forest that received 2000 mm precipitation yr<sup>-1</sup>, but 1–3% of annual litter production in a Malaysian rain forest that received 5000 mm precipitation yr<sup>-1</sup>.

Accumulation of dung from domestic mammalian grazers has become a serious problem in many arid and semi-arid ecosystems (see Box above). Termites can remove as much as 100% of cattle dung in 3 mos (Coe 1977, Herrick and Lal 1996, Whitford et al. 1982). On average, termites in the tropics remove 33% of dung in a particular habitat within one month of deposition (Freyman et al. 2008). In the absence of termites, dung would require 25–30 yrs to disappear (Whitford 1986). Dung beetles and earthworms are also important consumers of dung in many tropical and subtropical ecosystems (e.g., Coe 1977, Holter 1979, Kohlmann 1991).

Relatively few studies have provided estimates of wood consumption by bark- and wood-boring insects, despite their recognized importance to wood decomposition. Zhong and Schowalter (1989) reported that bark beetles consumed 0.1–7.6% of inner bark, and wood-boring beetles consumed an additional 0.05–2.3% during the first year of decomposition, depending on conifer tree species. Ambrosia beetles consumed 0–0.2% of the sapwood during the first year. Schowalter et al. (1998) found that virtually the entire inner bark of oak logs was consumed by beetles during the first two years of decomposition,



**FIG. 14.4** Rate of gallery carton deposition (top) and mass loss (bottom) of creosotebush, *Larrea tridentata*, and fluff grass, *Erioneuron pulchellum*, foliage when subterranean termites were present (black symbols) or absent (white symbols) in experimental plots in southern New Mexico. Litter (10g) was placed in aluminum mesh cylinders on the soil surface on 15 August 1979. Vertical lines represent standard errors. From Whitford, et al. (1982), with kind permission of the authors and Springer Science + Business Media.

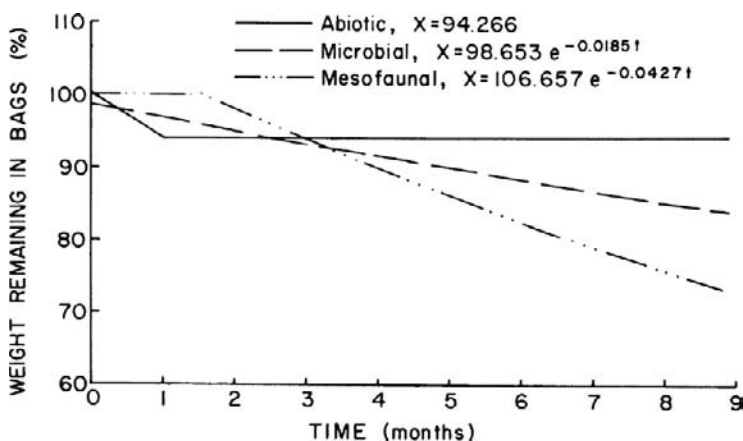
facilitating separation of the outer bark and exposing the sapwood surface to generalized saprophytic microorganisms. Edmonds and Eglitis (1989) used exclusion techniques to demonstrate that, over a 10 yr period, bark beetles and wood borers increased the decay rates of large Douglas-fir logs (42 cm diameter at breast height) by 12% and of small logs (26 cm diameter at breast height) by 70%.

Payne (1965) explored the effects of carrion feeders on carrion decay during the summer in South Carolina, U.S. He placed baby pig carcasses under replicated treatment cages, open at the bottom, that either permitted or restricted access to insects. Carcasses were weighed at intervals. Carcasses exposed to insects lost 90% of their mass in six days, whereas those protected from insects lost only 30% of their mass in this period, followed by a gradual loss of mass, with 20% mass remaining in mummified pigs after 100 days.

Not all studies indicate significant effects of litter fragmentation by macroarthropods. Setälä et al. (1996) reported that manipulation of micro-, meso- and macroarthropods in litter baskets resulted in slower decay rates in the presence of macroarthropods. Most litter in baskets with macroarthropods (millipedes and earthworms) was converted into large fecal pellets that decayed slowly.

A number of studies have demonstrated that microarthropods are responsible for up to 80% of the total decay rate, depending on litter quality and ecosystem (Table 14.1, Fig. 14.5) (Coleman et al. 2004, González and Seastedt 2001, Hättenschwiler and Gasser 2005, Heneghan et al. 1999, Seastedt 1984). Seastedt (1984) suggested that an apparent, but non-significant, inverse relationship between decay rate due to microarthropods and total decay rate indicated a greater contribution of arthropods to decomposition of recalcitrant litter fractions compared to more labile fractions. Tian et al. (1995) subsequently reported that millipedes and earthworms contributed more to the decomposition of plant residues with high C/N, lignin and polyphenol contents than to high quality plant residues.

In addition to accelerating litter decomposition, detritivores also synergize the effect of plant species diversity. Hättenschwiler and Gasser (2005) found that slow-decomposing oak, *Quercus petraea*, litter disappeared 26% faster in combination with other litter species than in single-species litter when millipedes, *Glomeris marginata*, were present, but showed no difference in decay rate among diversity treatments when millipedes were excluded, even when earthworms, *Aporrectodea longa*, were present. By contrast, faster-decomposing *Prunus avium* and *Tilia platyphyllos* decayed more slowly with increasing litter species diversity in the presence of earthworms. Variable results were found for



**FIG. 14.5** Decomposition rate of blue grama grass in litterbags treated to permit decomposition by abiotic factors alone, abiotic factors + microbes, and abiotic factors + microbes + mesofauna (microarthropods). Decomposition in the abiotic treatment was insignificant after the first month; decomposition showed a 2 mo time lag in the treatment including mesofauna. From Vossbrinck et al. (1979) with permission from the Ecological Society of America.

other litter species, but this study demonstrated that detritivores interact with litter species diversity to accelerate or decelerate decomposition.

## 2. Microbial Respiration

Microbial decomposers are responsible for about 95% of total heterotrophic respiration in litter and soil. Arthropods generally increase microbial respiration rates and carbon flux but may reduce respiration rates if they overgraze microbial resources (Huhta et al. 1991, Seastedt 1984). Several studies have documented an increase in microbial respiration as a result of increased arthropod access to detrital substrate and stimulation of microbial production.

Many arthropods directly transport and inoculate saprophytic microorganisms into organic residues. Some fungi colonize wood in advance of insect excavation and degrade cellulose into labile carbohydrates that subsequently are used by insects (Bridges and Perry 1985, French and Roeser 1972, Morgan 1968). Others may be acquired accidentally by insects during feeding or movement through colonized material. Behan and Hill (1978) documented transmission of fungal spores by oribatid mites.

Mixing of organic material and microbes during passage through detritivore guts ensures infusion of consumed litter with decomposers and may alter litter quality in ways that stimulate microbial production (Maraun and Scheu 1996). Gut mixing is especially important for species such as termites and other wood-borers that require microbial digestion of cellulose and lignin into labile carbohydrates (Breznak and Brune 1994), which may fuel nitrogen fixation by microbes in xylophage guts (Nardi et al. 2002).

Litter fragmentation by detritivores greatly increases oxygen penetration, as well as the surface area exposed for microbial colonization. Zhong and Schowalter (1989) reported that ambrosia beetle densities averaged 300 m<sup>-2</sup> bark surface in Douglas-fir and western hemlock, *Tsuga heterophylla*, coarse woody debris, and their galleries extended 9–14 cm in 4–9 cm thick sapwood, indicating that considerable sapwood volume was made accessible to microbes that colonized the gallery walls. The entire sapwood volume was colonized by various fungi within the first year after coarse woody debris was cut.

Fungivorous and bacteriophagous arthropods stimulate microbial activity by maximizing microbial production. As discussed for herbivore effects on plants in Chapter 12, low-to-moderate levels of grazing often stimulate productivity of the microflora by alleviating competition, altering microbial species composition, and gouging new detrital surfaces for microbial colonization. Microarthropods also can stimulate microbial respiration by preying on bacteriophagous and mycophagous nematodes (Seastedt 1984, Setälä et al. 1996). Higher levels of grazing may depress microbial biomass and reduce respiration rates (Huhta et al. 1991, Seastedt 1984).

Seastedt (1984) suggested a way to evaluate the importance of three pathways of microbial enhancement by arthropods, based on the tendency of microbes to immobilize nitrogen in detritus until the C:N ratio approaches 10–20:1. Where arthropods affect decomposition primarily through comminution, the nitrogen content of litter should be similar with or without fauna. Alternatively, where arthropods stimulate microbial growth and respiration rates, the C:N ratio of litter with fauna should be less than the ratio without fauna. Finally, where arthropods graze microbial tissues as fast as they are produced, C:N ratio of litter should be constant, and mass should decrease.

Seasonal variation in arthropod effects on microbial production and biomass may explain the variable results and conclusions obtained from earlier studies. Maraun and Scheu (1996) reported that fragmentation and digestion of beech leaf litter by the millipede,

*G. marginata*, increased microbial biomass and respiration in February and May, but reduced microbial biomass and respiration in August and November. They concluded that feeding by millipedes generally increased nutrient (nitrogen and phosphorus) availability, but that these nutrients were used for microbial growth only when carbon resources were adequate, as occurred early in the year. Depletion of carbon resources relative to nutrient availability in detritus limited microbial growth later in the year.

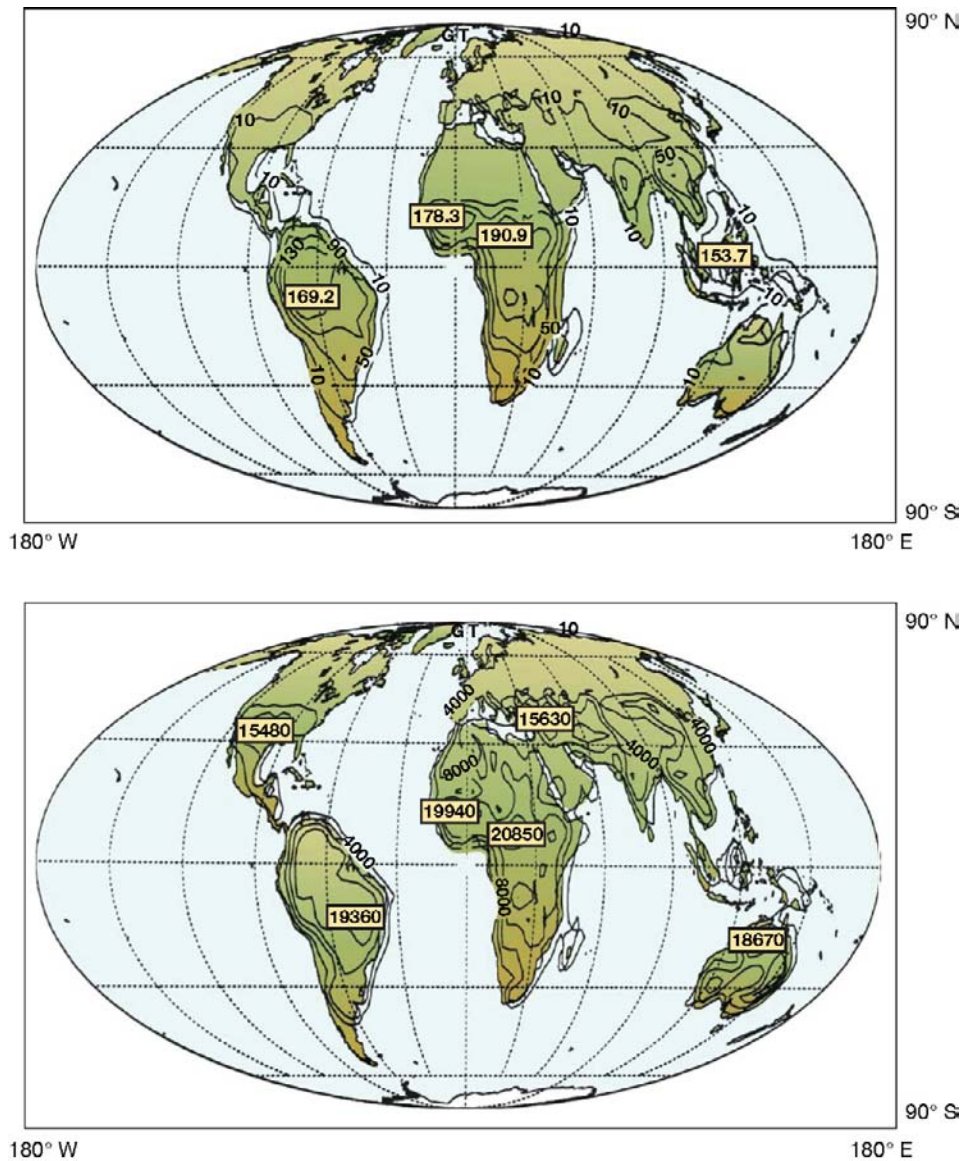
Although  $\text{CO}_2$  is the major product of litter decomposition, incomplete oxidation of organic compounds occurs in some ecosystems, resulting in release of other trace gases, especially methane (Khalil et al. 1990). P. Zimmerman et al. (1982) first suggested that termites could contribute up to 35% of global emissions of methane. A number of arthropod species, including most tropical representatives of millipedes, cockroaches, termites and scarab beetles, are important hosts for methanogenic bacteria and are relatively important sources of biogenic global methane emissions (Hackstein and Stumm 1994).

Termites have received the greatest attention as sources of methane because their relatively sealed colonies are warm and humid, with low oxygen concentrations that favor fermentation processes and emission of methane or acetate (Brauman et al. 1992, Wheeler et al. 1996). Thirty of 36 temperate and tropical termite species assayed by Brauman et al. (1992), Hackstein and Stumm (1994) and Wheeler et al. (1996) produced methane and/or acetate. Generally, acetogenic bacteria outproduce methanogenic bacteria in wood- and grass-feeding termites, but methanogenic bacteria are much more important in fungus-growing and soil-feeding termites (Brauman et al. 1992).

P. Zimmerman et al. (1982) suggested that tropical deforestation and conversion to pasture and agricultural land could increase the biomass and methane emissions of fungus-growing and soil-feeding termites, but Martius et al. (1996) concluded that methane emissions from termites in deforested areas in Amazonia would not contribute significantly to global methane fluxes. Khalil et al. (1990), Martius et al. (1993) and Sanderson (1996) calculated  $\text{CO}_2$  and methane fluxes, based on global distribution of termite biomass, and concluded that termites contribute ca. 2% of the total global flux of  $\text{CO}_2$  ( $3500 \text{ tg yr}^{-1}$ ) and 4–5% of the global flux of methane ( $\leq 20 \text{ tg yr}^{-1}$ ) (Fig. 14.6). However, emissions of  $\text{CO}_2$  by termites are 25–50% of the annual emissions from fossil fuel combustion (Khalil et al. 1990). Furthermore, Cattânio et al. (2002) reported unexpected emissions of methane following experimental drought treatment in the eastern Amazon. Since dry soils should not provide the anaerobic conditions necessary for methane emission, they concluded that the most plausible explanation was that root mortality supported increased termite activity in the dried soil. Contributions to atmospheric composition by this ancient insect group may have been more substantial prior to anthropogenic production of  $\text{CO}_2$ , methane and other trace gases.

### 3. Mineralization

Changes in elemental concentrations in decomposing litter represent net mineralization rates. Net mineralization includes the loss of elements due to mineralization, balanced with accumulation by microflora of elements that enter as microparticulates, precipitation and leachate, or are transferred (e.g., via hyphae) from other organic material (Harmon et al. 1994, Lodge et al. 2008, Schowalter et al. 1998, Seastedt 1984). Although microbial biomass typically is a negligible component of litter mass, microbes often represent a large proportion of the total nutrient content of decomposing detritus, and they significantly affect the nutrient content of the litter–microbial complex (e.g., Lodge et al. 2008, Seastedt 1984). Arthropods affect net mineralization in two measurable ways: through



**FIG. 14.6** Geographic distribution of emissions of methane (top) and carbon dioxide (bottom) by termites. Units are  $10^6 \text{ kg yr}^{-1}$ . From Sanderson (1996) courtesy of the American Geophysical Union.

mass loss and assimilation of consumed nutrients, and through effects on nutrient content of the litter-microbe system. Seastedt (1984) proposed the following equation to indicate the relative effect of arthropods on mineralization:

$$Y = (\% \text{ mass}_i / \% \text{ mass}_x) \times (\text{concentration}_i / \text{concentration}_x) \quad (14.2)$$

Where  $Y$  is the relative arthropod effect,  $\% \text{ mass}_i$  is the percentage of initial mass remaining that has been accessible to arthropods,  $\% \text{ mass}_x$  is the percentage of initial mass remaining that has been unavailable to arthropods, and  $\text{concentration}_i$  and  $\text{concentration}_x$  are the

respective concentrations of a given element. Net immobilization of an element is indicated by  $Y > 1$ , and net loss is indicated by  $Y < 1$ . Temporal changes in nutrient content depend on the structural position of the element within organic molecules, microbial use of the element, and the form and amounts of the element entering the detritus from other sources.

Nitrogen generally is considered to be the element most likely to limit growth of plants and animals, and its release from decomposing litter often is correlated with plant productivity (Vitousek 1982, T.E. Wood et al. 2009). As noted above, saprophytic microbes typically immobilize nitrogen until sufficient carbon has been respired to make carbon or some other element more limiting than nitrogen (Maraun and Scheu 1996, Schowalter et al. 1998, Seastedt 1984). Thereafter, the amount of nitrogen released should equal the amount of carbon oxidized. Microbes have a considerable capacity to absorb nitrogen from precipitation, canopy leachate, and animal excrement (Fig. 12.14) (Lovett and Ruesink 1995, Seastedt and Crossley 1983, Stadler and Müller 1996), and fungi can translocate limited nitrogen and other nutrients from hyphae in nutrient-rich substrates to hyphae in nutrient-poor substrates (Lodge et al. 2008), thereby permitting nitrogen mineralization and immobilization even at high C:N ratios. Generally, exclusion of microarthropods decreases the concentration of nitrogen in litter, but the absolute amounts of nitrogen in litter are decreased or unaffected by microarthropod feeding activities (Seastedt 1984).

Yokoyama et al. (1991) compared nitrogen transformations among cattle dung (balls) that were colonized by dung beetles, *Onthophagus lenzii*, uncolonized dung, and residual dung remaining after beetle departure. They reported that dung beetles reduced ammonia volatilization from dung 50%, by reducing pH and ammonium concentration in dung (through mixing of dung and soil). However, dung beetles increased denitrification 2–3-fold by increasing the rate of nitrate formation. Dung beetles also increased nitrogen fixation 2–10-fold, perhaps by reducing inorganic nitrogen concentrations in a substrate of easily-decomposable organic matter.

More recently, Nardi et al. (2002) found that nitrogen-fixing microbes are abundant in the hindguts of a wide variety of detritivores. Based on measured rates of nitrogen fixation by gut microbes, especially among termites, they calculated rates in ecosystems to be as high as  $10\text{--}40 \text{ kg ha}^{-1} \text{ yr}^{-1}$ .

Phosphorus concentrations often show an initial decline due to leaching, but subsequently reach an asymptote determined by microbial biomass (Schowalter and Sabin 1991, Schowalter et al. 1998, Seastedt 1984). Microarthropods can increase or decrease rates of phosphorus mineralization, presumably as a result of their effect on microbial biomass (Seastedt 1984).

Calcium dynamics are highly variable. This element often is bound in organic acids (e.g., calcium oxalate), as well as in elemental and inorganic forms in detritus. Some fungi accumulate high concentrations of this element (Cromack et al. 1975, 1977, Schowalter et al. 1998), and some litter arthropods, especially millipedes and oribatid mites, have highly calcified exoskeletons (Norton and Behan-Pelletier 1991, Reichle et al. 1969). Nevertheless, the calcium content in arthropod tissues is low compared to annual inputs in litter. No consistent arthropod effects on calcium mineralization have been apparent (Seastedt 1984).

Potassium and sodium are highly soluble elements, and their initial losses (via leaching) from decomposing litter invariably exceed mass losses (Schowalter and Sabin 1991, Schowalter et al. 1998, Seastedt 1984). Amounts of these elements entering the litter in



precipitation or throughfall approach or exceed amounts entering as litterfall. In addition, these elements are not bound in organic molecules, so their supply in elemental form is adequate to meet the needs of microflora. Arthropods have been shown to affect mineralization of  $^{134}\text{Cs}$  or  $^{137}\text{Cs}$ , which have been used as analogs of potassium (Crossley and Witkamp 1964, Witkamp and Crossley 1966), but not mineralization of potassium (Seastedt 1984). Sodium content often increases in decomposing litter, especially decomposing wood (Cromack et al. 1977, Schowalter et al. 1998). Sollins et al. (1987) suggested that this increase represented the accumulation of arthropod tissues and products, which typically contain relatively high concentrations of sodium (e.g., Reichle et al. 1969). However, Schowalter et al. (1998) reported an increase in concentrations of sodium during early stages of wood decomposition, prior to sufficient accumulation of arthropod tissues. They suggested that this increase reflected accumulation by decay fungi, which contained high concentrations of sodium in their fruiting structures. Fungi and bacteria have no known physiological requirement for sodium (Cromack et al. 1977). Accumulation of sodium, and other limiting nutrients, in decomposing wood may represent a mechanism for attracting sodium-limited animals that transport fungi to new wood resources.

Sulfur accumulation in decomposing wood or forest and grassland soils (Schowalter et al. 1998, Stanko-Golden et al. 1994, Strickland and Fitzgerald 1986) reflects both the physical adsorption of sulfate and the biogenic formation of sulfonates by bacteria (Autry and Fitzgerald 1993). Although arthropods have no demonstrated role in these processes, arthropod feeding on the bacterial groups which are responsible for sulfur mobilization or immobilization should influence sulfur dynamics. Because sulfur flux plays a major role in soil acidification and cation leaching, factors affecting sulfur immobilization require further investigation.

The generally insignificant effects of arthropods on net mineralization rates, compared to their substantial effects on mass loss, can be attributed to the compensatory effects of arthropods on microbial biomass. The stimulation by arthropods of microbial respiration and immobilization of nutrients results in the loss of litter mass, especially carbon flux through respiration, but not of the standing crops of other elements within litter (Seastedt 1984). Other aspects of fragmentation also may contribute to nutrient retention, rather than loss. Aquatic comminuters generally fragment detritus into finer particles more amenable to downstream transport (J. Wallace and Webster 1996). However, some filter-feeders concentrate fine detrital material into larger fecal pellets that are more likely to remain in the aquatic ecosystem (e.g., Wotton et al. 1998). Some shredders deposit feces in burrows, thereby incorporating the nutrients into the substrate (R. Wagner 1991). Furthermore, Seastedt (2000) noted that most studies of terrestrial detritivore effects have been relatively short-term. Accumulating data (e.g., Setälä et al. 1996) suggest that mixing of recalcitrant organic matter and mineral soil in the guts of some arthropods may produce stable soil aggregates that reduce the decay rate of organic material.

## B. Soil Structure, Fertility and Infiltration

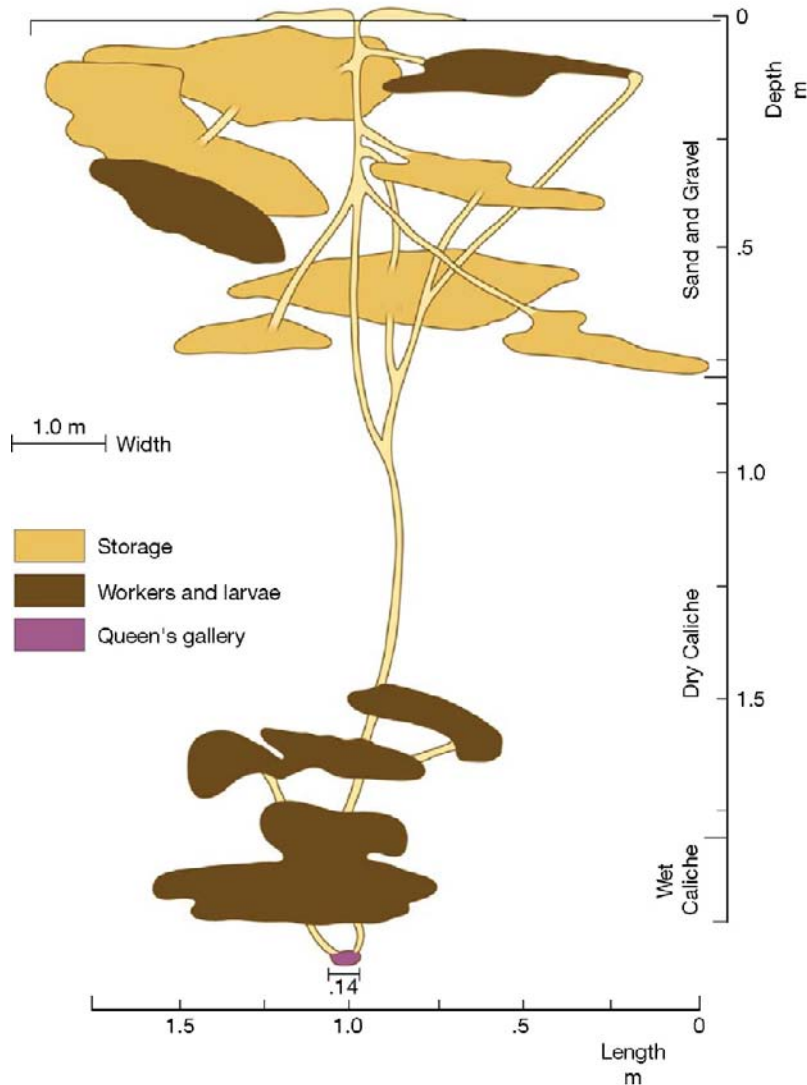
Fossorial arthropods alter the structure of the soil by redistributing soil and organic material and increasing soil porosity (J. Anderson 1988). Porosity determines the depth to which air and water can penetrate the substrate. A variety of substrate-nesting vertebrates, colonial arthropods, and detritivorous arthropods and earthworms affect the spatial and temporal patterns of substrate structure, organic matter content, and infiltration in terrestrial and aquatic systems.

Defecation by a larval caddisfly, *Sericostoma personatum*, increases subsurface organic content in a stream ecosystem by 75–185% (R. Wagner 1991). The caddisfly feeds on detritus on the surface of the stream bed at night and burrows into the stream bed during the day, trapping organic matter in burrows. Frouz et al. (2004) found higher survival of chironomid larvae in benthic substrates composed primarily of sand and/or accumulated chironomid fecal pellet aggregates (particle diameter >0.25 mm), compared to substrates composed of fine organic sediment (<0.25mm). Accumulated fecal pellets increased mean substrate particle size, leading to more extensive larval tunneling and higher dissolved oxygen levels also seen in sand substrates.

Ants and termites are particularly important soil engineers (Dangerfield et al. 1998, Jouquet et al. 2006, MacMahon et al. 2000). Colonies of these insects often occur at high densities and introduce cavities into large volumes of substrate. Eldridge (1993) reported that densities of funnel ant, *Aphaenogaster barbigula*, nest entrances could reach 37 m<sup>-2</sup>, equivalent to 9% of the surface area over portions of the eastern Australian landscape. Nests of leaf-cutting ants, *Atta vollenweideri*, reach depths of >3 m in pastures in western Paraguay (Jonkman 1978). J. Moser (2006) excavated a leaf-cutting ant, *Atta texana*, nest in northern Louisiana, U.S.A., and found 97 fungus-garden chambers, 27 dormancy chambers, 45 detritus chambers (for disposal of depleted foliage substrate) and a central cavity at 4 m depth in which the ants and fungus overwinter (Fig. 14.2). The nest extended over an area of 12 × 17 m on the surface and was at least 4 m deep. The bottom of the colony could not be reached, but vertical tunnels extended to at least 7.5 m and might have extended to the water table at 32 m. Whitford et al. (1976) excavated nests of desert harvester ants, *Pogonomyrmex* spp., in New Mexico, U.S., and mapped their 3-dimensional structure (Fig. 14.7). Colony densities were 21–23 ha<sup>-1</sup> at four sites, and each colony consisted of 12–15 interconnected galleries (each about 0.035 m<sup>3</sup>) within a 1.1 m<sup>3</sup> volume (1.5 m diameter × 2 m deep) of soil, equivalent to about 10 m<sup>3</sup> ha<sup>-1</sup> of cavity space (Fig. 14.7). These colonies frequently penetrated the calcified hardpan (caliche) layer, 1.7–1.8 m below the surface.

The infusion of large soil volumes with galleries and tunnels greatly alters soil structure and chemistry. Termite and ant nests typically represent sites of concentrated organic matter and nutrients (Ackerman et al. 2007, J. Anderson 1988, Culver and Beattie 1983, Herzog et al. 1976, Holdo and McDowell 2004, J. Jones 1990, Jurgensen et al. 2008, Lesica and Konnowski 1998, MacMahon et al. 2000, Mahaney et al. 1999, A. Risch et al. 2005, Salick et al. 1983, D. Wagner 1997, D. Wagner and Jones 2004, D. Wagner et al. 1997). Nests may have concentrations of macronutrients 2–3 times higher than surrounding soil (Fig. 14.8). J. Jones (1990) and Salick et al. (1983) noted that soils outside termite nest zones become relatively depleted of organic matter and nutrients. L. Parker et al. (1982) reported that experimental exclusion of termites for 4 yrs increased soil nitrogen concentration by 11%. Ant nests also have been found to have higher rates of microbial activity, and carbon and nitrogen mineralization than do surrounding soils (Dauber and Wolters 2000, Lenoir et al. 2001, D. Wagner and Jones 2004) and represent sites of concentrated CO<sub>2</sub> efflux (Domisch et al. 2006, Jurgensen et al. 2008, A. Risch et al. 2005).

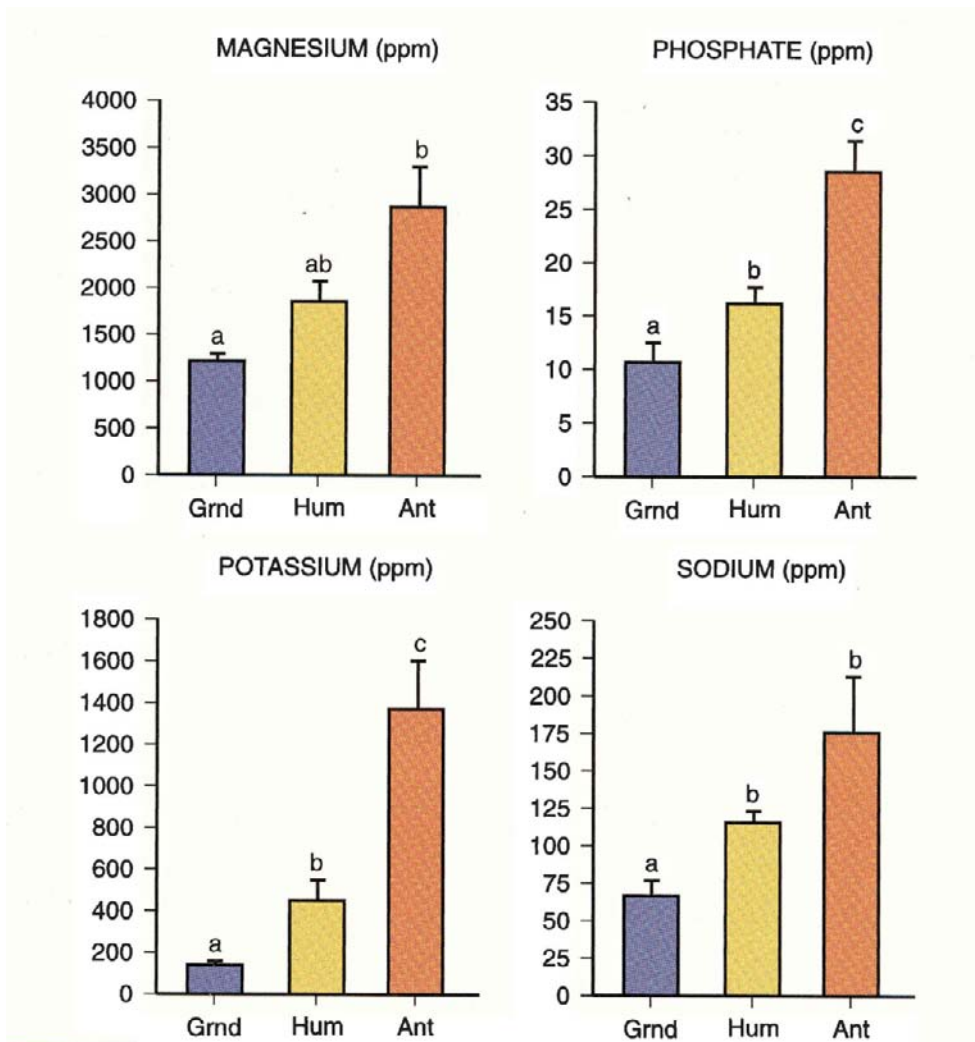
Nest pH often differs from that of surrounding soil. Mahaney et al. (1999) found significantly higher pH in termite mounds than in surrounding soils. Jonkman (1978) noted that soil within leaf-cutter ant, *Atta* spp., nests tended to have higher pH than did soil outside the nest. However, D. Wagner et al. (1997) measured significantly lower pH (6.1) in nests of harvester ants, *Pogonomyrmex barbatus*, than in reference soil (6.4).



**FIG. 14.7** Vertical structure of a harvester ant, *Pogonomyrmex rugosus*, nest in southern New Mexico. From Whitford, et al. (1976) with kind permission of the authors and Springer Science + Business Media.

Lenoir et al. (2001) reported that *Formica rufa* nests had a higher pH than did surrounding soil at one site and a lower pH than did surrounding soil at a second site, both in Sweden. Ant mounds in Germany did not differ in pH from surrounding soils (Dauber and Wolters 2000).

Termites and ants also transport large amounts of soil from lower horizons to the surface and above for the construction of nests (Fig. 14.9), gallery tunnels, and “carton”, the soil deposited around litter material by termites for protection and to retain moisture during feeding above ground (Fig. 14.10) (Whitford 1986). Whitford et al. (1982) reported that termites brought 10–27 g m<sup>-2</sup> of fine-textured soil material (35% coarse sand, 45%



**FIG. 14.8** Concentrations of major nutrients from bog soil (Grnd), hummocks (Hum) and *Formica* nests (Ant) in bogs in Montana, U.S. Vertical bars represent 1 SE. Means with different letters are significantly different at  $P < 0.05$ . From Lesica and Kannowski (1998) with permission from The University of Notre Dame.

medium fine sand, and 21% very fine sand, clay and silt) to the surface and deposited 6–20 g of soil carton per gram of litter removed (Fig. 14.4). Herrick and Lal (1996) found that termites deposited an average of 2.0 g of soil at the surface for every gram of dung removed. Mahaney et al. (1999) reported that termite mound soil contained significantly more (20%) clay than did surrounding soils.

A variety of vertebrate species in Africa have been observed to selectively ingest termite mound soil (Holdo and McDowell 2004, Mahaney et al. 1999). Mahaney et al. (1999) suggested that the higher clay content of these mounds, along with their higher pH and nutrient concentrations, could mitigate gastrointestinal ailments and explain the consumption of mound soil by chimpanzees. Termite mound soils, as well as surrounding soils, had high concentrations of metahalloysite, used pharmaceutically, and other clay



**FIG. 14.9** Termite castle in northern Australian woodland. Dimensions are approximately 3 m height and 1.5 m diameter.

minerals that showed mean binding capacities of 74–95% for four tested alkaloids. Chimpanzees could bind most of the dietary toxins present in 1–10 g of leaves by eating 100 mg of termite mound soil.

A number of studies have demonstrated effects of soil animals on soil moisture (Fig. 14.11). Experimental reduction or removal of litter from the soil surface increases soil temperature and evaporation, and reduces infiltration of water. Burrowing and redistribution of soil and litter by animals increase soil porosity, water infiltration, and the stability of soil aggregates that control water- and nutrient-holding capacity. Conversely, the dense pavement over mound-building termite nests restricts water infiltration but increases moisture in the runoff zone surrounding the mound (I. Ackerman et al. 2007, Eldridge 1993, 1994).

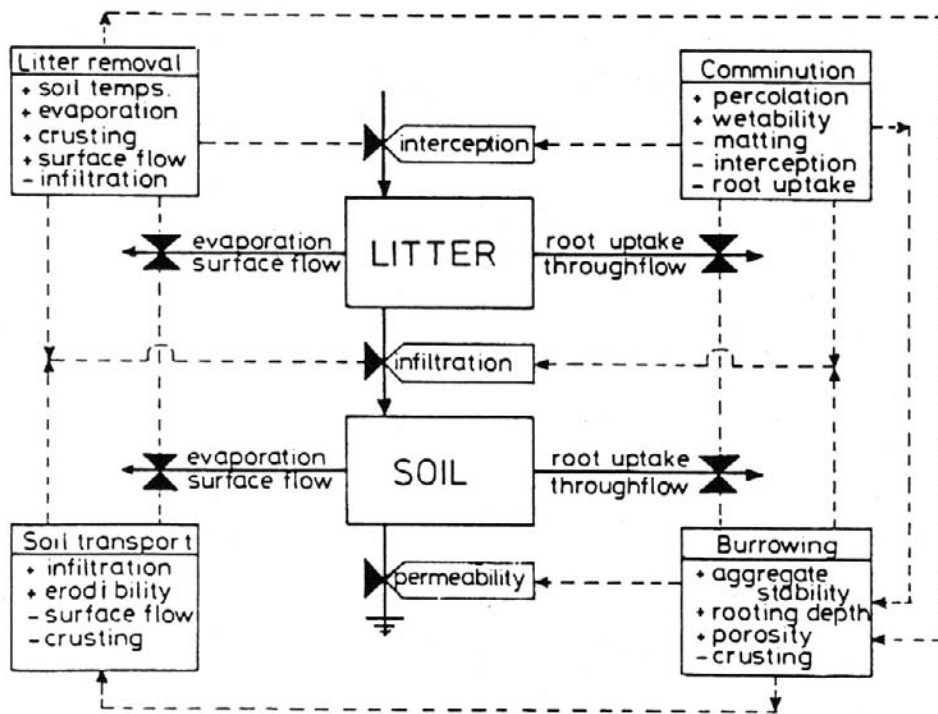
Ant and termite nests have particularly important effects on soil moisture because of the large substrate surface areas and volumes affected (MacMahon et al. 2000). D. Wagner (1997) reported that soil near ant nests had higher moisture content than did more distant soil. Elkins et al. (1986) compared runoff and water infiltration in plots with termites



**FIG. 14.10** Termite gallery carton on stems of dead creosotebush. Soil particles are cemented together to provide protection and moisture control during termite feeding on detrital material.

present or excluded during the previous four years in New Mexico, U.S. Plots with < 10% plant cover had higher infiltration rates when termites were present ( $88 \text{ mm hr}^{-1}$ ) than when termites were absent ( $51 \text{ mm hr}^{-1}$ ); runoff volumes were twice as high in the termite-free plots with low plant cover (40 mm) as in untreated plots (20 mm). Infiltration and runoff volumes did not differ between shrub-dominated plots (higher vegetation cover) with or without termites.

Eldridge (1993, 1994) measured effects of funnel ants and subterranean harvester termites, *Drepanotermes* spp., on the infiltration of water in semi-arid eastern Australia. He found that infiltration rates in soils with ant nest entrances were 4–10-fold higher ( $1030\text{--}1380 \text{ mm hr}^{-1}$ ) than in soils without nest entrances ( $120\text{--}340 \text{ mm hr}^{-1}$ ). Infiltration rate was correlated positively with nest entrance diameter. However, infiltration rate on the sub-circular pavements covering the surface over termite nests was an order of magnitude lower than in the annular zone surrounding the pavement or in inter-pavement soils (Fig. 14.12). The cemented surface of the pavement redistributed water and nutrients



**FIG. 14.11** Effects of soil invertebrates on soil water balance. Reprinted from J. Anderson, (1988) with permission from Elsevier.

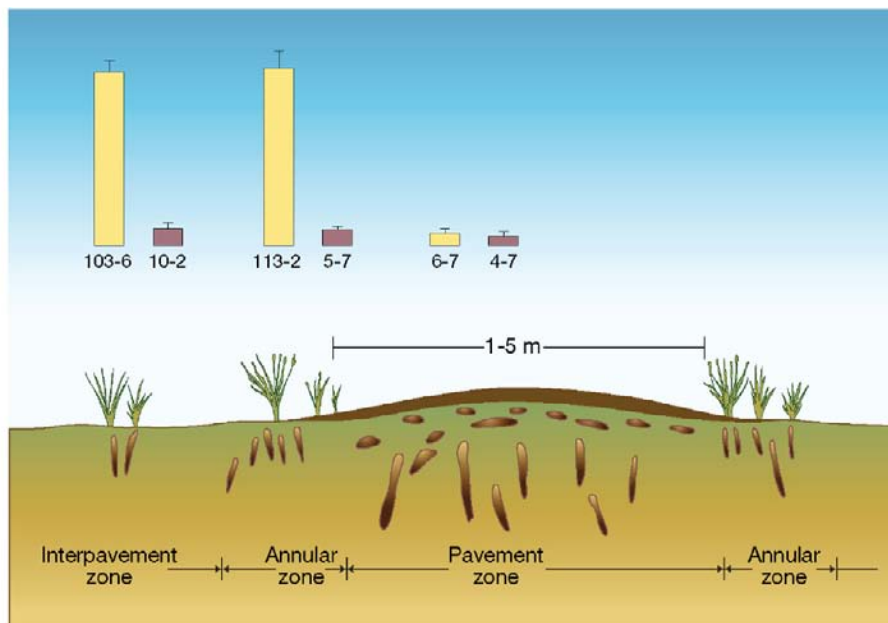
from the pavement to the surrounding annular zone. Ant and termite control of infiltration creates wetter microsites in moisture-limited environments.

### C. Primary Production and Vegetation Dynamics

Through control of decomposition, mineralization and pedogenesis, detritivorous and fossorial arthropods have the capacity to control nutrient availability for, and perhaps uptake by, plants (Crossley 1977, Setälä and Huhta 1991). In particular, the release of nitrogen and phosphorus from decaying organic matter often is correlated with plant productivity (Vitousek 1982, T.E. Wood et al. 2009). Some species, especially ants, directly alter the vegetation around their nests by concentrating harvested seeds in nests and/or by clipping plants that surround nests (MacMahon et al. 2000, see Chapter 13). However, relatively few studies have measured the effect of detritivores and burrowers on plant growth or vegetation dynamics.

C. Edwards and Lofty (1978) compared seedling emergence and shoot and root growth of barley between pots of intact, sterilized soil (from fields in which seed had been either drilled into the soil or planted during plowing) with microarthropods or earthworms either absent or reintroduced. Percent seedling emergence, plant height, and root weight were higher in plowed soil and direct-drilled soil with animals, compared to sterile direct-drilled soil, suggesting important effects of soil animals on mineralization, soil porosity and infiltration that support primary production.

R. Ingham et al. (1985) inoculated microcosms of blue grama grass, *Bouteloua gracilis*, in sandy loam soil low in inorganic nitrogen, with bacteria or fungi. Half of each microflora



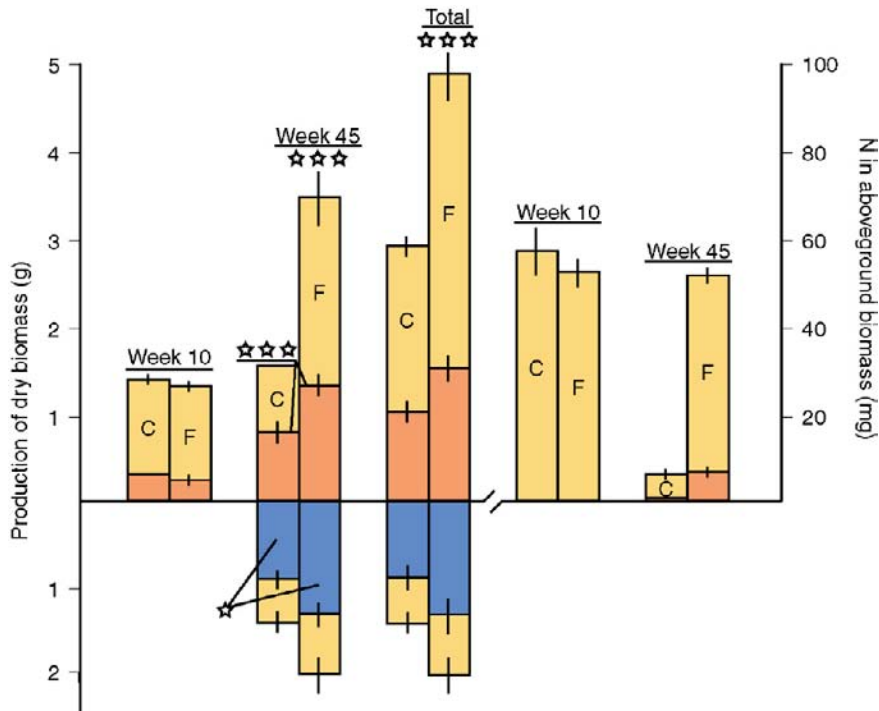
**FIG. 14.12** Effect of termite colony structure on infiltration of water under ponded conditions (brown) and under tension (yellow). Vertical lines indicate 1 standard error of the mean. Reprinted from Eldridge (1994) with permission from Elsevier.

treatment was inoculated with microbivorous nematodes. Plants growing in soil with bacteria and bacteriophagous nematodes grew faster and acquired more nitrogen initially than did plants in soil with bacteria only. Addition of mycophagous nematodes did not increase plant growth. These differences in plant growth resulted from greater nitrogen mineralization by bacteria (compared to fungi), excretion of  $\text{NH}_4^+\text{-N}$  by bacteriophagous (but not mycophagous) nematodes, and rapid uptake of available nitrogen by plants. Mycophagous nematodes did not increase plant growth or nitrogen uptake over fungi alone, because these nematodes excreted less  $\text{NH}_4^+\text{-N}$ , and the fungus alone mineralized sufficient nitrogen for plant growth.

In a unique, definitive study, Setälä and Huhta (1991) created laboratory microcosms with birch seedlings, *Betula pendula*, that had been planted in partially sterilized soil that was reinoculated with soil microorganisms only or with soil microorganisms and a diverse soil fauna. During two growing periods, the presence of soil fauna increased birch leaf, stem and root biomass by 70%, 53% and 38%, respectively, and increased foliar nitrogen and phosphorus contents 3-fold and 1.5-fold, respectively, compared to controls with microorganisms only (Fig. 14.13). More recently, Laakso and Setälä (1999) found that experimental removal of microbe- or detritus-feeding soil fauna, especially the microbi-detritivorous enchytraeid worm, *Cognettia sphagnetorum*, reduced plant biomass and uptake of nitrogen.

Soil arthropods could influence plant growth by inoculating roots with mycorrhizal fungi. Rabatin and Stinner (1988) reported that 28–97% of soil animals contained mycorrhizal spores or hyphae in their guts. Conversely, fungivore grazing on mycorrhizae could inhibit plant growth by interfering with nutrient uptake.

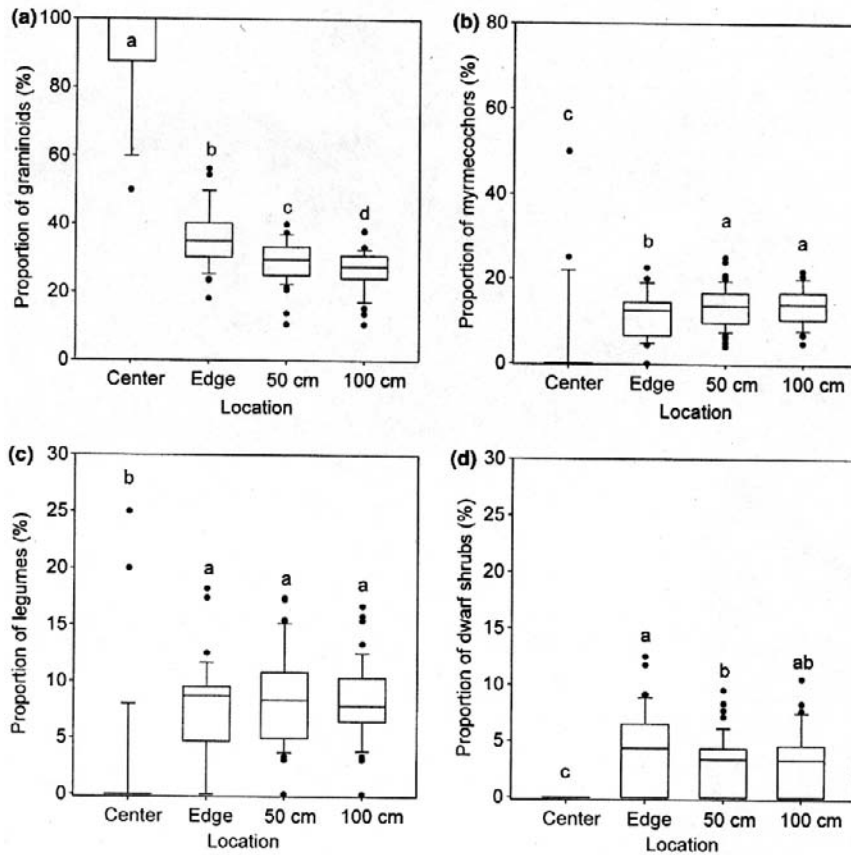




**FIG. 14.13** Biomass production (left of break in horizontal axis) and nitrogen accumulation (right of break in horizontal axis) of birch, *Betula pendula*, seedlings. Bars above the horizontal axis are stems (orange) and leaves (yellow); bars below the horizontal axis are roots in humus (blue) and roots in mineral soil (yellow). C=fauna removed; F=refaunated. Vertical lines represent 1 standard deviation for all data (except nitrogen at week 45, where vertical lines represent minimum and maximum values). For C vs. F, \*= $P < 0.05$ ; \*\*\*= $P < 0.001$ . Stem nitrogen was not measured week 10. From Setälä and Huhta (1991) with permission from the Ecological Society of America.

Soil animals also influence community dynamics. Although ant and termite nests may represent relatively minor components of total soil carbon and nutrient pools, they substantially increase spatial heterogeneity of soil water and nutrient availability (Domisch et al. 2006, Jurgensen et al. 2008, MacMahon et al. 2000, A. Risch et al. 2005), thereby influencing patterns of community development. Zaragoza et al. (2007) reported that distinct protozoan communities were associated with ant nest mounds, compared to reference soils 5 m away from ant nests. Several studies have demonstrated that ant and termite mounds typically support distinct plant communities, compared to surrounding soil (Fig. 14.14, Brody et al. 2010, Garrettson et al. 1998, Q. Guo 1998, Holdo and McDowell 2004, T. King 1977a, M. Schütz et al. 2008), but the effect on vegetation development may differ between active and abandoned mounds (Lesica and Kanno 1998, F. Smith and Yeaton 1998).

Lesica and Kanno (1998) reported that wood ants, *Formica podzolica*, were responsible for mound formation in peat bogs in Montana, U.S. Mounds provided an elevated habitat that was warmer, better aerated, and had higher nutrient content than did the surrounding peat surfaces (Fig. 14.8). Although active mounds supported only a few species of grasses, abandoned nests supported shrubs, as well as plant species that



**FIG. 14.14** Vegetation composition along 46 transects from *Formica exsecta* mound centers into surrounding alpine grassland in Switzerland. Box plots indicate median, 25<sup>th</sup> and 75<sup>th</sup> percentiles, black lines are 10<sup>th</sup> and 90<sup>th</sup> percentiles, and filled circles are all values below 10<sup>th</sup> and above 90<sup>th</sup> percentiles. Different letters indicate significant differences ( $P < 0.05$ ). Note different scales for axes. From M. Schütz et al. (2008) with permission from the authors and John Wiley & Sons.

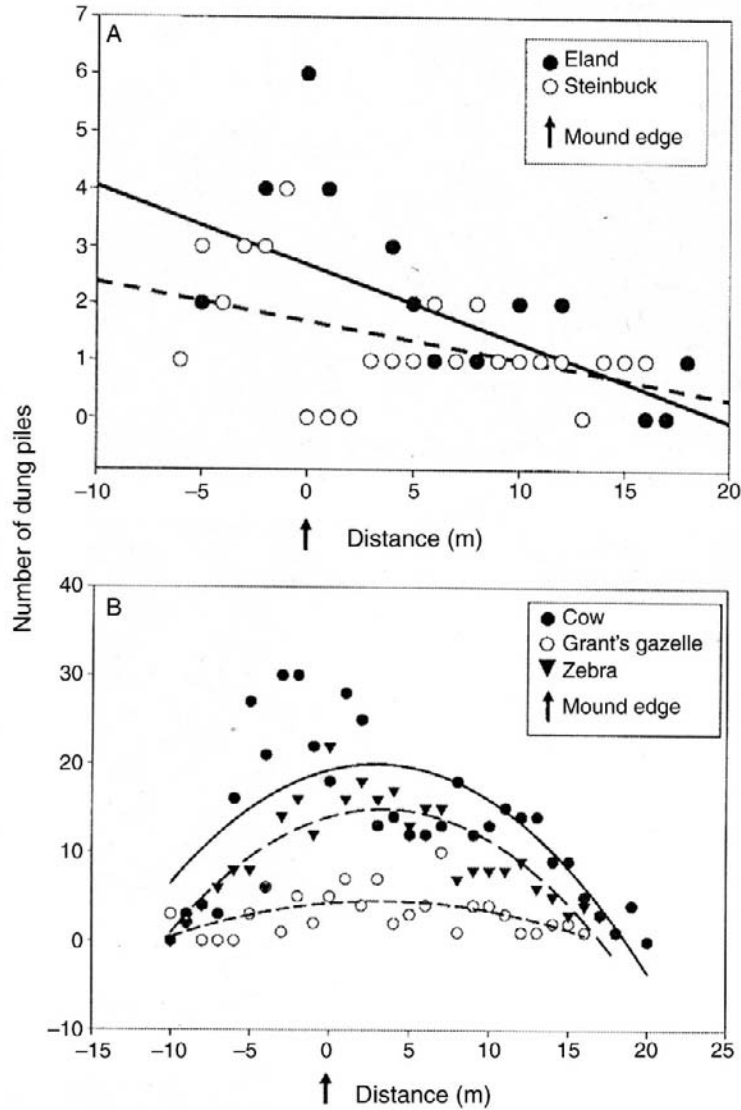
could not grow in the saturated peat surface. The ants foraged primarily on honeydew from aphids that were tended on shrubs, indicating a positive feedback relationship.

Abandoned nests of leaf-cutter ants, *A. vollenweideri*, serve as sites of accelerated succession in Paraguayan pastures (Jonkman 1978). Collapse of the nest chamber forms a depression that holds water and facilitates the development of woody vegetation. At high nest densities, these oases coalesce, greatly increasing forest area. Brenner and Silva (1995) found that active nests of *Atta laevigata* were associated more frequently with groves of trees, and the size of nests increased with grove size and the abundance of forest tree species in Venezuelan savanna, suggesting that active nests both facilitated and were facilitated by formation of groves.

L. Parker et al. (1982) demonstrated that termite exclusion significantly reduced the biomass of four annual plant species and significantly increased the biomass of one annual plant species. They observed an overall trend toward increased biomass of annual plants in plots with termites excluded. These results probably reflected increased nitrogen availability in plots from which termites were excluded, compared to plots with

unmanipulated termite abundance. I. Ackerman et al. (2007) found that active termite mounds in abandoned farmland in central Amazonia inhibited water retention and restricted secondary succession. By contrast, Bloesch (2008) reported that *Macrotermes* spp. mounds provided spatially-distinct elevated sites for development of wooded thickets in seasonally flooded savanna landscapes in East Africa.

The high nutrient concentrations of termite and ant nests are incorporated by plants growing on or near nests and become available to higher trophic levels (Fig. 14.15).



**FIG. 14.15** Vertebrate dung density at increasing distance from termite, *Odontotermes* spp., mound centers into surrounding savanna in north-central Kenya. A) for eland and steinbuck, a linear regression explained 40% and 19% of variance, respectively. B) for Grant's gazelle, zebra and cow, a second-order polynomial explained 26%, 73% and 54% of variance, respectively. In all cases, the first term was not significant, but the second term was highly significant ( $P < 0.01$ ). From Brody et al. (2010) with permission from the Ecological Society of America.

Holdo and McDowell (2004) reported that trees growing on termite mounds had higher concentrations of all nutrients tested, except sodium and crude protein, than did trees from the surrounding woodland matrix in Zimbabwe. Trees on mounds were also subjected to more intense feeding by elephants. Termite and ant nests thereby affect food availability and feeding patterns for herbivores, providing indirect positive feedback for herbivore effects on litter quality and availability for detritivores. Brody et al. (2010) found that *Acacia drepanolobium* trees growing at the edge of termite, *Odonototermes* spp., mounds in Kenya showed twice the foliar nitrogen content and seed production as trees growing away from mounds, due to enhanced soil N and P in mounds. Fox-Dobbs et al. (2010) further reported that *A. drepanolobium* trees off mounds acquired a higher percentage of N via fixation (55–80%) than did trees near mounds (40–50%), reflecting the higher availability and use of soil-based N near termite mounds. Exclusion of vertebrate herbivores, which preferentially used mound vegetation, as evidenced by patterns of dung deposition (Fig. 14.15), did not affect these results, demonstrating that soil enrichment by termites, rather than dung and urine deposition by vertebrates, was responsible for the vegetation responses (Brody et al. 2010).

### III. SUMMARY

Decomposition and pedogenesis are major ecosystem processes that affect biogeochemical cycling, trace gas fluxes, soil fertility and primary production. Decomposition of organic matter involves four component processes: photo-oxidation, leaching, comminution, and mineralization. Arthropods are key factors influencing comminution and mineralization.

The functional groups that are involved in decomposition include coarse comminuters that fragment large materials and fine comminuters that fragment smaller materials, often those produced by large comminuters. In aquatic ecosystems, scrapers and shredders represent coarse comminuters, whereas gatherers and filterers represent fine comminuters. Xylophages represent a specialized group of comminuters that fragment woody litter in terrestrial and aquatic ecosystems. Carrion feeders reduce carcasses, and coprophages feed on animal excrement. Fungivores and bacteriovores fragment detrital material while grazing on microflora. Fossorial functional groups include subterranean nesters that excavate simple burrows, gatherers that return detrital or other organic materials to nesting areas, and fossorial feeders that consume organic material and/or soil and mix biotic and abiotic materials in their wake.

Evaluation of the effects of detritivores and burrowers on decomposition and pedogenesis requires appropriate methods for measuring animal abundances and process rates. Abundances of detritivores or burrowers can be manipulated using exclusion and microcosm techniques, and detritivory can be measured as the product of detritivore abundance and individual consumption rate or as the rate of disappearance of substrate. Decomposition is measured most commonly as respiration rate, as the ratio of litter input to litter standing crop, or as the rate of litter disappearance. Isotopic tracers also provide data on decomposition rate.

Decomposition rates typically are higher in mesic than in arid ecosystems. Different functional groups dominate different ecosystems, depending on the availability and quality of detrital resources. For example, shredders dominate headwater streams where coarse detrital inputs are the primary resource, whereas filterers dominate larger streams with greater availability of suspended fine organic material. Xylophages occur only in ecosystems with woody residues. Decomposition generally can be modeled as a multiple

negative exponential decay function over time, with decay constants proportional to the quality of litter components. Typically, an initial high decay rate represents the rapid loss of labile materials, and successively lower decay rates represent the subsequent, slower losses of recalcitrant materials, e.g., lignin and cellulose. Most studies have been relatively short term. Recent long-term studies suggest that the mixing of recalcitrant materials and soil in arthropod guts may create stable aggregates that decay very slowly.

Detritivores affect decomposition in three ways: through comminution, through their effects on microbial biomass, and through effects on mineralization. Comminution increases detrital surface area and facilitates colonization and decay by microflora. Low-to-moderate levels of grazing on microflora stimulate microbial productivity and biomass, maximizing microbial activity and respiration. High levels of grazing may reduce microbial biomass and decomposition. Grazers also disperse fungi and bacteria to new substrates. Not all organic material is converted to  $\text{CO}_2$ . The low oxygen concentrations that characterize warm, humid termite colonies favor incomplete reduction of organic molecules to methane and other trace gases. Arthropod detritivores affect mineralization in different ways, depending on the chemical characteristics and biological use of the element. Detritivores often increase mineralization of nitrogen, but nitrogen released from detritus may be immobilized quickly by microorganisms.

Burrowers affect soil development by redistributing soil and organic matter. Ants and termites, in particular, excavate large volumes of soil and accumulate organic material in their centralized nests, mixing soil with organic material and influencing the distribution of soil nutrients and organic matter. Surrounding soils may become depleted in soil carbon and nutrients.

Detritivore and burrower effects on mineralization and soil composition can affect primary production and vegetation dynamics. Elevated moisture and nutrient concentrations in, or adjacent to, ant and termite nests support distinct vegetation and may facilitate succession following colony abandonment. A few studies have demonstrated increased plant growth, altered vegetation structure, and increased herbivory resulting from detritivore-induced nutrient mobilization.

# Insects as Regulators of Ecosystem Processes

## I. Development of the Concept

## II. Ecosystems as Cybernetic Systems

- A. *Properties of Cybernetic Systems*
- B. *Ecosystem Homeostasis*
- C. *Definition of Stability*
- D. *Regulation of NPP by Biodiversity*
- E. *Regulation of NPP by Insects*

## III. Summary

### **A new perspective of insect herbivores**

Could insects regulate ecosystem processes, i.e., could they provide stabilizing feedback? This hypothesis is one of the most revolutionary ideas to emerge from integration of insect ecology and ecosystem ecology, because it is the antithesis of our traditional view based on millennia of antagonistic interaction with insects as competitors, disease vectors or just nuisances.

Several lines of evidence indicate that native insects function as regulators of ecosystem processes. First, native herbivore populations are strongly regulated by host chemistry and availability and by predation (see Chapter 6). Small populations stimulate plant production, whereas outbreaks reduce production by stressed and/or abundant plant species, thereby pruning and thinning host plants and reducing plant competition (Trumble et al. 1993, S. Williamson et al. 1989, see Chapter 12). Second, herbivory can improve plant water balance (Kolb et al. 1999) and stimulate nutrient turnover (S. Chapman et al. 2003, Christenson et al. 2002, Classen et al. 2005, Frost and Hunter 2004, 2007, 2008a, b, Schowalter et al. 1991, Seastedt et al. 1983), potentially ameliorating stressful limitations (see Chapter 12). Finally, outbreaks of native species typically promote the growth of less-stressed host or non-host species with lower resource requirements (Ritchie et al. 1998). Insects also function as regulators of litter decomposition and nutrient availability for plants (Christenson et al. 2002, Frost and Hunter 2007, Seastedt 1984, see Chapter 14), and as predators and parasites that co-regulate populations of other animals, including the largest vertebrates (J. Day et al. 2000, Marra et al. 2004, Poinar and Poinar 2004b, 2007, see Chapter 8). These roles also affect global climate. As a result, ecosystem conditions may be maintained within a narrower range of variation than would result from absence of insects.

Although accumulating evidence suggests that insects can regulate ecosystem processes, definitive experiments are difficult to perform (because of the difficulty of manipulating insect

(Cont.)

abundances over sufficiently large areas), and results are subject to interpretation. For example, does extensive tree mortality resulting from native bark beetle outbreaks represent a disturbance that increases variability in ecosystem structure and function (e.g., Romme et al. 1986) or a reversal of anthropogenic changes and return to the lower density of site-adapted species that prevailed prior to forest management (Schowalter 2008), and the management recommendation for these forests (North et al. 2007)? Although arguing against regulation by insects, Romme et al. (1986) noted that ecosystem production in some forests returned to pre-outbreak levels within ten years. For long-lived ecosystems, outbreaks by native insect herbivores might reduce variability in ecosystem conditions, compared to more extensive mortality, and longer recovery, that could result from extended tree competition and stress in the absence of insect outbreaks.

## INTRODUCTION

INSECTS, AND OTHER ORGANISMS, INEVITABLY AFFECT THEIR ENVIRONMENT through their spatial and temporal patterns of resource acquisition and redistribution. Insects respond to environmental changes in ways that dramatically alter ecosystem conditions, as discussed in Chapters 12–14. These effects of organisms do not necessarily provide cybernetic (stabilizing) regulation. However, the hypothesis that insects can stabilize ecosystem properties through feedback regulation is one of the most important and revolutionary concepts to emerge from research on insect ecology, and it should be considered when making pest management decisions in natural ecosystems.

The concept of self-regulation is a key aspect of ecosystem ecology. Vegetation has a documented role in ameliorating variation in climate and biogeochemical cycling (Chapter 11), and vegetative succession facilitates the recovery of ecosystem functions after disturbances. However, the concept of self-regulating ecosystems has seemed to be inconsistent with evolutionary theory (which emphasizes selection of “selfish” attributes) (e.g., Pianka 1974), with variable successional trends following disturbance (e.g., Horn 1981), and with the lack of obvious mechanisms for maintaining homeostasis (e.g., Engelberg and Boyarsky 1979).

The debate over the self-regulating capacity of ecosystems, and especially the role of insects, is somewhat reminiscent of the debate on the now-recognized importance of density-dependent feedback regulation of population size (Chapter 6), and is a useful example of how science develops. The outcome of this debate has significant consequences for how we manage ecosystems and their biotic resources. Although controversial, this concept is an important aspect of insect ecology, and its major issues are the subject of this chapter.

### I. DEVELOPMENT OF THE CONCEPT

The intellectual roots of ecosystem self-regulation lie in Darwin’s (1859) recognition that some adaptations apparently benefit a group of organisms more than the individual, leading to selection for population stability. The concept of altruism and selection for homeostasis at supra-organismal levels has remained an important issue, despite recurring challenges and alternative models (e.g., Axelrod and Hamilton 1981, Schowalter 1981, D.S. Wilson 1976, 1997).

Behavioral ecologists have been challenged to explain the evolution of altruistic behaviors that are fundamental to social organization. Even sexual reproduction could be

considered a form of self-restraint, because individuals contribute only half the genotype of their progeny through sexual reproduction, compared to the entire genotype of their progeny through asexual reproduction (Pianka 1974). Cooperative interactions, such as mutualism, and self-sacrificing behavior, such as suppression of reproduction and suicidal defense by workers of social insects, have been more difficult to explain in terms of individual selection. Haldane (1932) proposed a model in which altruism would have a selective advantage if the starting gene frequency were high enough, and the benefits to the group outweighed individual disadvantage. This model raised obvious questions about the origin of the altruist genes and the relative advantages and disadvantages that would be necessary for increased frequency of altruist genes.

Group selection theory was advanced during the early 1960s by Wynne-Edwards (1963, 1965), who proposed that social behavior arose as individuals evolved to curtail their own individual fitnesses to enhance survival of the group. Populations that do not restrain combat among their members or that overexploit their resources have a higher probability of extinction, than do populations that regulate combat or resource use. Selection thus should favor demes with traits which regulate their densities, i.e., maintain homeostasis in group size. Behaviors such as territoriality, restraint in conflict, and suppressed reproduction by subordinate individuals (including workers in social insect colonies) thereby reflect selection (feedback) for traits that prevent destructive interactions or oscillations in group size.

This hypothesis was challenged for its lack of explicit evolutionary models or experimental tests that could explain the progressive evolution of homeostasis at the group level, i.e., demonstration of an individual advantage to altruistic individuals over selfish individuals. Furthermore, the devices proposed by Wynne-Edwards, by which individuals curtail their individual fitnesses and communicate their density, and the degree to which each individual should decrease its individual fitness, were inconsistent with available evidence or could be explained better by models of individual fitness (E. Wilson 1973). Nevertheless, the concept of group selection was recognized as an important aspect of social evolution (E. Wilson 1973). W. Hamilton (1964) and J.M. Smith (1964) developed an evolutionary model, based on **kin selection**, whereby individual fitness is increased by behaviors that favor survival of relatives with similar genotypes. They introduced a new term, **inclusive fitness**, to describe the contributions of both personal reproduction and reproduction by near kin to individual fitness. For example, care for the offspring of one's siblings increases an individual's fitness to the extent that it contributes to the survival of related genotypes. Failure to provide sufficient care for the offspring of siblings reduces the survival of family members.

This concept explained evolution of altruistic behaviors, such as maternal care, shared rearing of offspring among related individuals, alarm calls (that may draw attention of predators to the caller) and voluntary suppression of reproduction and suicidal defense by workers in colonies of social insects, which typically benefit close relatives. For social Hymenoptera, W. Hamilton (1964) noted that males are produced from unfertilized eggs and have unpaired chromosomes. Accordingly, all the daughters in the colony inherit only one type of gamete from their father and thereby share 50% of their genes through this source. In addition, they share another 25%, on average, of their genes in common from their mother. Overall, the daughters share 75% of their genes with each other, compared to only 50% of their genes with their mother. Therefore, workers maximize their fitness by helping to rear siblings, rather than by having their own offspring.

This model does not apply to termites. Husseneder et al. (1999) and Thorne (1997) suggested that developmental and ecological factors, such as slow development, iteroparity,



overlap of generations, a food-rich environment, high risk of dispersal, and group defense, may be more important than genetics in the maintenance of termite eusociality, whatever factors may have favored its original development.

Levins (1970) and Boorman and Levitt (1972) proposed **interdemic selection** models to account for differential extinction rates among demes of metapopulations that differ in altruistic traits. In the Levins model, colonists from small populations found other small populations in habitable sites. Increasing the frequency of altruist genes decreases the probability of extinction of these small populations, i.e., cooperation elevates and maintains each deme above the extinction threshold (see Chapters 6 and 7). In the Boorman–Levitt model, colonists from a large, stable population found small, marginal populations in satellite habitats. Altruist genes do not influence extinction rates until marginal populations reach demographic carrying capacity, i.e., altruism prevents destructive population increase above carrying capacity (see Chapters 6 and 7). Both models require restrictive conditions for the evolution of altruist genes. Matthews and Matthews (2010) noted that group selection requires that an allele must become established by selection at the individual level. Thereafter, selection could favor demes with altruist genes that reduce extinction rates, relative to demes without these genes. Interdemic selection has become a central theme in developing concepts of metapopulation dynamics (Chapter 7).

Meanwhile, the concept of group selection was implicit in early models of ecological succession and community development. The facilitation model of succession proposed by Clements (1916) and elaborated by E. Odum (1953, 1969) emphasized the apparently progressive development of a stable, “climax”, ecosystem through succession. Each successional stage altered conditions in ways that benefitted the replacing species more than itself. However, such facilitation contradicted the individual self-interest that was fundamental to the theory of natural selection. Furthermore, identification of alternative models of succession, including the inhibition model (Chapter 10), made succession appear to be more consistent with evolutionary theory.

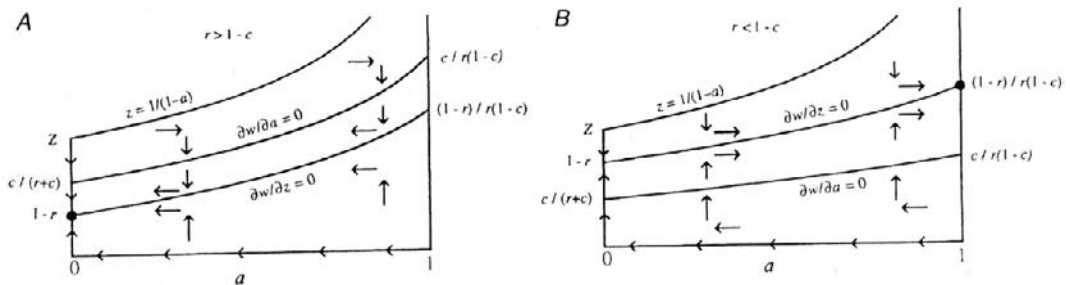
D.S. Wilson (1976, 1997) developed a model that specifically applied the concept of group selection at the community level. Wilson recognized that individuals and species affect their own fitness through effects on their environment, including the fitness of other individuals. For example, earthworm effects on soil development stimulate plant growth, herbivory and litter production (see Chapter 14) and thereby increase the detrital resources exploited by the worms; an indirect positive feedback. Furthermore, spatial heterogeneity in population distribution, from large geographic to microsite scales, results in intra- and interdemic variation in effects of organisms on their community. Given sufficient iterations of Wilson’s model, every effect of a species on its community eventually affects that species, positively or negatively, through all possible feedback pathways. Intra- and interdemic variation in effects on the environment is subject to selection for adaptive traits of individuals.

The models described above help explain the increased frequency of altruist genes, but what selective factors can maintain altruist genes in the face of evolutionary pressure to “cheat” among non-related individuals? Trivers (1971) and Axelrod and Hamilton (1981) developed a model of **reciprocal altruism** based on the Prisoner’s Dilemma, in which each of two players can cooperate or defect. Each player can choose to cooperate or defect if the other player chooses to cooperate or defect. If the first player acts cooperatively, the benefit/cost for cooperation by the second player (reward for mutual cooperation) is less than that for defection (temptation for the first player to defect in the future); if the first player defects, the benefit/cost for cooperation by the second player (sucker’s payoff) is less than that for defection (punishment for mutual defection). Therefore, if the

interaction occurs only once, defection (non-cooperation) is always the optimal strategy, despite both individuals faring worse than they would if both cooperated. However, Axelrod and Hamilton (1981) recognized the probability of repeated interaction between pairs of unrelated individuals and addressed the initial viability (as well as final stability) of cooperative strategies in environments dominated by non-cooperating individuals or more heterogeneous environments composed of other individuals using a variety of strategies. After numerous computer simulations with a variety of strategies, they concluded that the most robust strategy in an environment of multiple strategies also was the simplest, **Tit-for-Tat**. This strategy involves cooperation based on reciprocity and a memory extending only one move back, i.e., never being the first to defect but retaliating after a defection by the other and forgiving after just one act of retaliation. They also found that once Tit-for-Tat was established, it resisted invasion by possible mutant strategies as long as the interacting individuals had a sufficiently large probability of meeting again.

Axelrod and Hamilton emphasized that Tit-for-Tat is not the only strategy that can be evolutionarily stable. The **Always Defect Strategy** also is evolutionarily stable, no matter what the probability of future interaction. They postulated that altruism could appear between close relatives, when each individual has partial interest in the partner's gain (i.e., rewards in terms of inclusive fitness), whether or not the partner cooperated. Once the altruist gene exists, selection would favor strategies that base cooperative behavior on recognition of cues, such as relatedness or previous reciprocal cooperation. Therefore, individuals in relatively stable environments are more likely to experience repeated interaction and selection for reciprocal cooperation than are individuals in unstable environments that provide low probabilities of future interaction.

S. Frank (1995) developed a mathematical model that could explain evolution of self-restraint and suppression of competition within groups as a result of the mutual benefit derived by preventing overexploitation of limiting resources (Fig. 15.1). This model demonstrated that kin selection alone could not explain evolution of complex regulatory

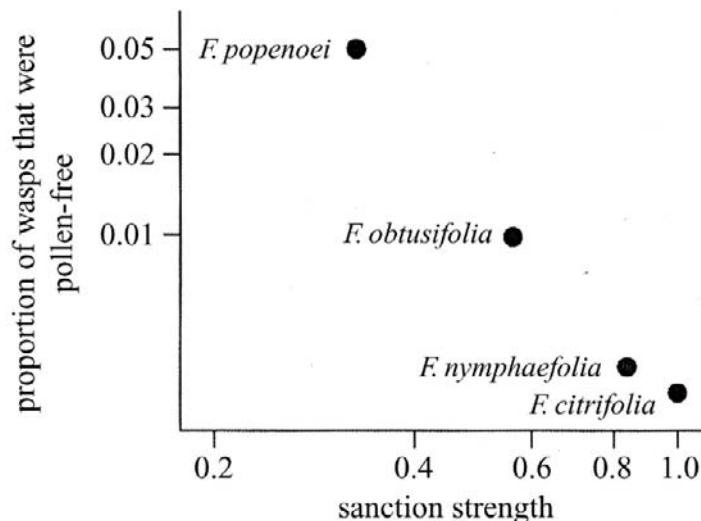


**FIG. 15.1** A minimal model for evolutionary dynamics of competitiveness,  $z$ , and mutual policing,  $a$ . A) high relatedness,  $r$ , relative to benefits of mutual policing,  $r > 1 - c$  (where  $c =$  cost), leads toward self-restraint, with  $z^* = 1 - r$  and no mutual policing,  $a^* = 0$ . B) low relatedness relative to benefits,  $r < 1 - c$ , leads toward full investment in mutual policing and complete repression of competition,  $a^* = 1$ . In A,  $c = r = 0.7$ ; in B,  $c = 0.2$  and  $r = 0.4$ . The gradient of fitness with respect to mutual policing,  $\delta w/\delta a$ , is calculated as the partial derivative of  $w_{ij}$  with respect to  $a_{ij}$ , evaluated at fixed trait values for all individuals,  $a_{ij} = a$  and  $z_{ij} = z$ . A similar approach is used for  $\delta w/\delta z$ . Although assumptions about costs, benefits and genetics complicate the analysis, this minimal mode demonstrates powerful selective pressure on self-restraint and mutual policing that favor increasingly complex evolutionary units. From Frank (1995) with permission from Nature, © Macmillan Magazines, Ltd.

mechanisms, such as Mendelian segregation of chromosomes during meiosis and mutual policing of workers in social insects, among unrelated units of selection. Rather, individuals invest resources in mutual suppression of competition but nevertheless strive for reproductive gain within the more equitable distribution of resources they help create.

Sanctions against cheaters have been demonstrated in recent studies. A. Smith et al. (2009) found that reproductive cheaters in ant, *Aphaenogaster cockerelli*, colonies can be reliably identified by cuticular hydrocarbons, particularly pentacosane, that are associated only with fertile individuals. Experimental application of pentacosane to workers elicited aggression by nestmates in colonies with queens but not in colonies without queens, in which workers had begun to reproduce. Although cheaters might benefit from suppressing the hydrocarbon profile, they are prevented from doing so by the reproductive physiology of hydrocarbon biosynthesis.

Jandér and Herre (2010) experimentally excluded pollen from a number of fig wasp species that are associated with actively- and passively-pollinated fig species and found that the actively-pollinated (but not passively-pollinated) fig species reduced the fitness of non-pollinating fig wasps through a combination of increased abortion of non-pollinated figs that had wasp eggs and reduced production of wasp offspring in figs that were not aborted. The relative proportion of unpollinated figs that matured and the relative number of wasp offspring that matured in unaborted figs were both significantly lower in actively-pollinated figs, compared to passively-pollinated figs. All fig species aborted figs that received neither pollen nor wasp eggs. The strength of sanctions against non-pollinating wasps (measured as 1-wasp relative fitness) varied from 0.33 to 1.0 for actively-pollinated fig species (Fig. 15.2), compared to 0 for passively-pollinated species. Pollen-free wasps occurred only among actively-pollinating species, and their prevalence was < 5% and negatively correlated with sanction strength. These data demonstrated substantial selection against cheaters as a means of stabilizing obligate mutualisms when providing a benefit to a host is costly, in terms of wasp time and energy.



**FIG. 15.2** The proportion of naturally-occurring pollen-free fig wasps as a function of sanction strength among actively-pollinated fig species. From Jandér and Herre (2010) with permission from the authors and the Royal Society.

These studies demonstrate that selection at supra-organismal levels must be viewed as contributing to the inclusive fitness of individuals derived from contribution to stabilizing interactions. Cooperating individuals have demonstrated greater ability in finding or exploiting uncommon or aggregated resources, defending shared resources, and mutual protection (W. Hamilton 1964). Cooperating predators, e.g., wolves and ants, have higher capture efficiency and can acquire larger prey, compared to solitary predators. The mass attack behavior of bark beetles is critical to the successful colonization of living trees. Co-existing caddisfly larvae can modify substrate conditions and near-surface water velocity, thereby enhancing food delivery (Cardinale et al. 2002). Animals in groups are more difficult for predators to attack. Mutualists can impose sanctions that reduce the fitness of cheaters, in order to maintain benefits (Jandér and Herre 2010).

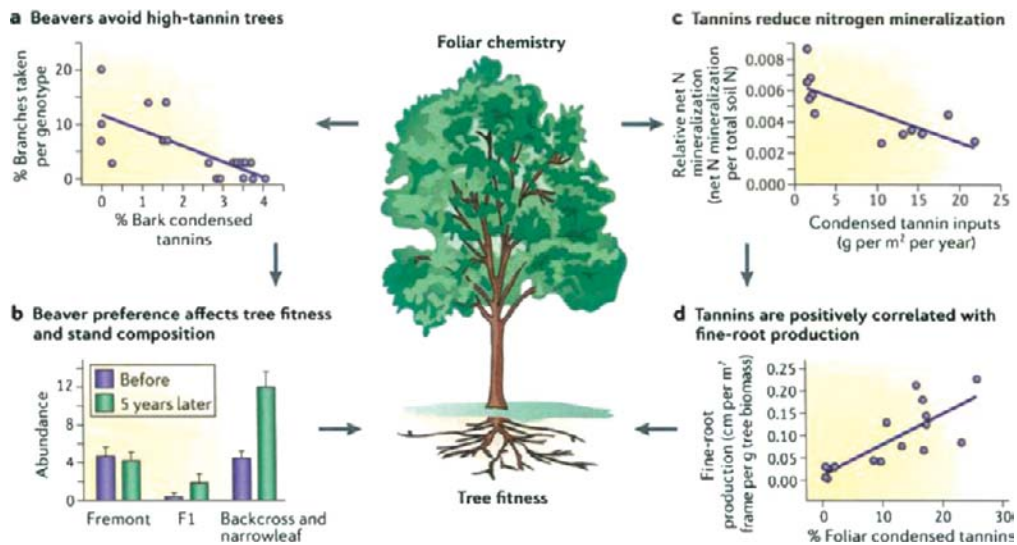
Reciprocal cooperation and sanctions against cheaters reflect selection via feedback from the effects of individuals on their environment. The strength of individual effects on the environment is greatest among directly interacting individuals and declines from the population to community levels (Fig. 1.2) (e.g., Lewinsohn and Price 1996). Reciprocal cooperation can explain the evolution of sexual reproduction and social behavior as the net result of trade-offs between maximizing the contribution of an individual's own genes to its progeny and maximizing the contribution of genes represented in the individual to progeny of its relatives. Similarly, species interactions represent trade-offs among positive and negative effects (see Chapter 8).

Population distribution in time and space (i.e., metapopulation dynamics, see Chapter 7) is a major factor that affects interaction strengths. Individuals dispersed in a regular pattern (Chapter 5) over an area will affect a large proportion of the total habitat and interact widely with co-occurring populations, whereas the same total number of individuals dispersed in an aggregated pattern will affect a smaller proportion of the total habitat, but may have a higher frequency of interactions with co-occurring populations in areas of local abundance. Consistency of population dispersion through time affects the long-term frequency of interactions and reinforcement of selection from generation to generation. Metapopulation dynamics interacting with disturbance dynamics provide the template for selection of species assemblages that are best adapted to local environmental variation.

Finally, negative feedback among all levels of ecosystem hierarchy can maintain system stability (Dambacher et al. 2003). Feedback at the genetic level is the basis for selection of stabilizing interactions (Fig. 15.3). Accumulating evidence demonstrates genetic variation, subject to selection, in biotic effects on ecosystem properties (Bailey et al. 2004, Classen et al. 2007a, D. Fischer et al. 2006, Schweitzer et al. 2004, 2005, Shuster et al. 2006, Whitham et al. 2003, 2006, Wimp et al. 2007), as well as responses to changing environmental conditions (e.g., Balanyá et al. 2006, W. Bradshaw and Holzapfel 2001, Edelaar et al. 2008, J. Hsu et al. 2006, Ralph et al. 2006). For example, D. Fischer et al. (2006) found that high tannin production in foliage requires increased root growth to compensate for tannin inhibition of soil N cycling. Thus, reduced N availability at the ecosystem level provides feedback on plant fitness, along with other factors, including herbivory, that favor increased tannin production.

## II. ECOSYSTEMS AS CYBERNETIC SYSTEMS

The cybernetic nature of ecosystems, from patch to global scales, has been a central theme of ecosystem ecology. J. Lovelock (1988) suggested that autotroph–heterotroph interactions have been responsible for the development and regulation of atmospheric composition and



**FIG. 15.3** Selection for species phenotype affects interactions with other species, that in turn feed back to affect fitness of the individuals that produced that phenotype. In this example, condensed tannin phenotype in poplar affects herbivore foraging, nutrient turnover and nutrient acquisition. a) and b) Beavers, *Castor canadensis*, select trees with low condensed tannin concentrations, leading to increased abundance of trees with higher condensed tannin concentrations and reduced abundance of trees with lower concentrations, affecting other species that depend on this tree for survival. c) and d) Increased foliar tannin concentration inhibits nitrogen mineralization from litter and soil, requiring the tree to produce more fine roots to acquire more limited soil nitrogen. Reprinted by permission from Nature, © 2006 Macmillan, Magazines Ltd (Whitham et al. 2006); a) data from Bailey et al. (2004) with permission from the Ecological Society of America, c) data from Schweitzer et al. (2004) with permission from John Wiley & Sons, and d) data from D. Fischer et al. (2006) with permission from the authors and Springer Science+Business Media.

climate that are suitable for the persistence of life. The ability of ecosystems to minimize variability in climate and rates of energy and nutrient fluxes would affect their regulatory responses to anthropogenic changes in global conditions.

## A. Properties of Cybernetic Systems

Cybernetic systems generally are characterized by: 1) information systems that integrate system components, 2) low-energy feedback regulators that have high-energy effects, and 3) goal-directed stabilization of high-energy processes. Mechanisms that sense deviation (perturbation) in the condition of the system communicate with mechanisms that function to reduce the amplitude and period of deviation. Negative feedback is the most commonly recognized method for stabilizing outputs. A thermostat represents a simple example of a negative feedback mechanism. The thermostat senses a departure in room temperature from a set level and communicates with a temperature control system that interacts with the thermostat to re-adjust temperature to the set level. The room system is maintained at temperatures within a narrow equilibrational range.

Organisms are recognized as cybernetic systems, with neurological networks for communicating physiological conditions and various feedback loops for maintaining homeostasis of biological functions. Cybernetic function is perhaps best developed among homeotherms. These organisms are capable of self-regulating their internal temperature through physiological mechanisms that sense change in body temperature and trigger changes in metabolic rate, blood flow and sweat that increase or decrease temperature, as necessary. However, energy demand is high for such regulation. Heterotherms also have physiological and behavioral mechanisms for adjusting body temperature within a somewhat wider range but with lower energy demand (see Chapters 2 and 4). Regardless of mechanism, the result is sufficient stability of metabolic processes for survival within normal ranges of environmental variation.

Although self-adjusting mechanical systems and organisms are the best-recognized examples of cybernetic systems, the properties of self-regulating systems have analogues at supra-organismal levels (B. Patten and Odum 1981, Schowalter 1985, 2000). Human families and societies express goals in terms of survival, economic growth, improved living conditions, etc., and accomplish these goals culturally through governing bodies, communication networks, and balances between reciprocal cooperation (e.g., trade agreements, treaties) and negative feedback (e.g., economic regulations, warfare).

## B. Ecosystem Homeostasis

E. Odum (1969) presented a number of testable hypotheses concerning ecosystem capacity to develop and maintain homeostasis, in terms of energy flow and biogeochemical cycling, during succession. Although subsequent research has shown that many of the predicted trends are not observed, at least in some ecosystems, Odum's hypotheses have focused debate on the concept of ecosystems as cybernetic systems. Engleberg and Boyarsky (1979) argued that ecosystems do not possess the critical goal-directed communication and low-cost/large-effect feedback systems required of cybernetic systems. Although ecosystems can be shown to possess these properties of cybernetic ecosystems, as described below, this debate cannot be resolved until ecosystem ecologists reach consensus on a definition, and measurable criteria, of stability and demonstrate that potential homeostatic mechanisms, such as biodiversity and herbivorous insects (see below), function to reduce variability in ecosystem conditions.

Although a discussion of ecosystem goals appears to be teleological, non-teleological goals can be identified, e.g., maximizing distance from thermodynamic ground (see B. Patten 1995), a requisite for all life. Stabilizing ecosystem conditions obviously would reduce the exposure of individuals and populations to extreme, and potentially lethal, departures from normal conditions. Furthermore, stable population sizes would prevent extreme fluctuations in abundances that would jeopardize stability of other variables. Hence, environmental heterogeneity might select for individual traits that contribute to stability of the ecosystem.

The argument that ecosystems do not possess centralized mechanisms for communicating departure in system condition and initiating responses (e.g., Engelberg and Boyarsky 1979) predated recognition of the pervasive communication network in ecosystems (see Chapters 2, 3 and 8). The importance of volatile chemicals for communicating resource conditions among species has been recognized relatively recently (I. Baldwin and Schultz 1983, Rhoades 1983, Sticher et al. 1997, Turlings et al. 1990, Zeringue 1987). The air-stream carries a blend of volatile chemicals, produced by the various members of the com-

munity, that advertises the abundance, distribution and condition of various organisms within the community and provides attractive or repellent cues. Changes in the chemical composition of the local atmosphere are an indicator of changes in the relative abundance and suitability of hosts, or the presence and proximity of competitors and predators. Sensitivity among organisms to the chemical composition of the atmosphere or water column may provide a global information network that communicates conditions for a variety of populations and initiates feedback responses.

Feedback loops are the primary mechanisms for maintaining ecosystem stability, regulating abundances and interaction strengths (W. Carson and Root 2000, Dambacher et al. 2003, de Ruiter et al. 1995, B. Patten and Odum 1981, Polis et al. 1997a, b, 1998). The combination of direct and indirect bottom-up (resource availability), top-down (predation) and lateral (competitive) interactions (see Chapters 6 and 8) generally represent negative feedback, stabilizing food webs by reducing the probability that populations increase to levels that threaten their resources (and, thereby, other species requiring those resources). Mutualistic interactions and other positive feedbacks reduce the probability of population decline to extinction thresholds. Although positive feedback is often viewed as destabilizing, such feedback may be most important when populations are small and probably is limited by negative feedbacks as populations grow beyond threshold sizes (Ulanowicz 1995). Such compensatory interactions may maintain ecosystem properties within relatively narrow ranges, despite spatial and temporal variation in abiotic conditions (Kratz et al. 1995, Ulanowicz 1995). Omnivory increases ecosystem stability, perhaps by increasing the number of linkages subject to feedback (Fagen 1997). Ecological succession represents one mechanism for the recovery of ecosystem properties following disturbance-induced departures from nominal conditions.

The concept of self-regulation does not require efficient feedback by all ecosystems or ecosystem components. Just as some organisms (recognized as cybernetic systems) have greater homeostatic ability than do others (e.g., homeotherms vs. heterotherms), some ecosystems demonstrate greater homeostatic ability than do others (J. Webster et al. 1975). Frequently disturbed ecosystems may be reestablished by relatively random assemblages of opportunistic colonists; frequent disturbance would select genes for rapid exploitation and dispersal but would provide little opportunity for repeated interaction that could lead to stabilizing cooperation (cf. Axelrod and Hamilton 1981). Some species increase variability or promote disturbance, e.g., brittle or flammable species (e.g., easily toppled *Cecropia* and flammable *Eucalyptus*). Insect outbreaks increase variation in some ecosystem parameters (Romme et al. 1986), often in ways that promote regeneration of resources (e.g., Schowalter et al. 1981a). On the other hand, relatively stable environments, such as tropical rainforests, also might not select for stabilizing interactions. However, stable environmental conditions should favor consistent species interactions and the evolution of reciprocal cooperation, such as is demonstrated by a diversity of mutualistic interactions in tropical forests. Selection for stabilizing interactions should be the greatest in ecosystems which are characterized by intermediate levels of environmental variation. Interactions that reduce such variation would contribute to individual inclusive fitnesses.

### C. Definition of Stability

B. Patten and Odum (1981) proposed that a number of time-invariant or regularly-oscillating ecosystem parameters represent potential goals for stabilization. These included total system production (P) and respiration (R), P:R ratio, total chlorophyll, total biomass,

nutrient pool sizes, species diversity, population sizes, etc. However, the degree of spatial and temporal variability of these parameters remains poorly known for most ecosystems, even those most intensively studied (Kratz et al. 1995).

Kratz et al. (1995) compiled data on the variability of climatic, edaphic, plant and animal variables from 12 Long-Term Ecological Research (LTER) Sites, representing forest, grassland, desert, lotic and lacustrine ecosystems, in the U.S. Unfortunately, given the common long-term goals of these projects, this comparison was limited because different variables and measurement techniques were represented among these sites. Nevertheless, Kratz et al. offered several important conclusions concerning variability.

First, the level of species combination (e.g., species, family, guild, total plants or animals) had a greater effect on observed variability in community structure than did spatial or temporal extent of the data. For plant parameters, species and guild-level data were more variable than were data for total plants; for animal parameters, species-level data were more variable than were guild-level data, and both were more variable than were total animal data. As discussed for food web properties in Chapter 9, the tendency to ignore diversity, especially of insects (albeit for logistic reasons), clearly affects our perception of variability. Detection of long-term trends or spatial patterns depends on data collection for parameters that are sufficiently sensitive to show significant differences but not so sensitive that their variability hinders detection of differences.

Second, spatial variability exceeded temporal variability. This result indicates that individual sites are inadequate to describe the range of variation among ecosystems within a landscape. Variability must be examined over larger spatial scales. Edaphic data were more variable than were climatic data, indicating high spatial variation in substrate properties, whereas common weather across landscapes homogenizes microclimatic conditions. This result could also be explained as the result of greater biotic modification of climatic variables, compared to substrate variables (see below).

Third, biotic data were more variable than were climatic or edaphic data. Organisms can exhibit exponential responses to incremental changes in abiotic conditions (see Chapter 6). The ability of animals to move and alter their spatial distribution quickly in response to environmental changes is reflected in greater variation in animal data, compared to plant data. However, animals also have greater ability to hide or escape sampling devices.

Finally, two sites, a desert and a lake, provided a sufficiently complete array of biotic and abiotic variables to permit comparison. These two ecosystem types represent contrasting properties. Deserts are exposed to highly variable and harsh abiotic conditions, but are interconnected within landscapes, whereas lakes exhibit relatively constant abiotic conditions (buffered from thermal change by their mass and the latent heat capacity of water, from pH change by bicarbonates, and from biological invasions by their isolation), but are isolated by land barriers. Comparison of variability between these contrasting ecosystems supported the hypothesis that deserts are more variable than lakes among years, but lakes are more variable than deserts among sites.

Kratz et al. (1995) provided important data on variation in a number of ecosystem parameters among ecosystem types. However, important questions remain. Which parameters are most important for stability? How much deviation can be tolerated? What temporal and spatial scales are relevant to ecosystem stability?

Among the parameters that could be stabilized as a result of species interactions, net primary production and biomass structure (living and dead) may be particularly important, because many other parameters, including energy, water and nutrient fluxes, trophic interactions, species diversity, population sizes, climate, and soil development, are directly



or indirectly determined by net primary production or biomass structure (Boulton et al. 1992, see Chapter 11). In particular, the ability of ecosystems to modify their internal microclimate, to protect and modify soils, and to provide stable resource bases for primary and secondary producers depends on NPP and biomass structure. Therefore, natural selection over long periods of co-evolution should favor individuals whose interactions stabilize these ecosystem parameters. NPP may be stabilized over long time periods as a result of compensatory community dynamics and biological interactions, such as those resulting from biodiversity and herbivory (see below).

No studies have addressed the limits of deviation, for any parameter, within which ecosystems can be regarded as qualitatively stable. Traditional views of stability have emphasized consistent species composition, at the local scale, but shifts in species composition may be a mechanism for maintaining stability in other ecosystem parameters, at the landscape or watershed scale. This obviously is an important issue for evaluating stability and predicting effects of global environmental changes. However, given the variety of ecosystem parameters and their integration at the global scale, within the context of anthropogenic change, this issue will be difficult to resolve.

The range of parameter values within which ecosystems are conditionally stable may be related to characteristic fluctuations in environmental conditions or nutrient fluxes. For example, biomass accumulation increases ecosystem storage capacity and ability to resist variation in resource availability (J. Webster et al. 1975), but it also increases ecosystem vulnerability to some disturbances, including fire and storms. Complex ecosystems with high storage capacity (i.e., forests) are the most buffered ecosystems, in terms of regulation of internal climate, soil conditions and resource supply, but also fuel the most catastrophic fires under drought conditions and suffer the greatest damage during cyclonic storms. Hence, ecosystems with lower biomass, but rapid turnover of matter or nutrients, may be more stable under some environmental conditions. Species interactions that periodically increase rates of nutrient fluxes and reduce biomass (e.g., herbivore outbreaks) traditionally have been viewed as evidence of instability, but may contribute to stability of ecosystems in which biomass accumulation or rates of nutrient turnover from detritus are destabilizing (de Mazancourt et al. 1998, Loreau 1995), such as resulting from anthropogenic changes.

No studies have addressed the appropriate temporal and spatial scales over which stability should be evaluated, nor whether these scales should be the same for all ecosystems. Most studies of ecosystem processes represent periods shorter than 10 yrs, although some ecosystem studies now span 60 yrs. The long time scales representing processes such as succession exceed the scale of human lifetimes and have required substitution of temporal variation by spatial variation (e.g., chronosequences within a landscape). Data from such studies have limited utility, because individual patches have unique conditions and are influenced by the conditions of surrounding patches (Kratz et al. 1995, Woodwell 1993, J. Zimmerman et al. 2010). Therefore, temporal changes at the patch scale often follow different successional trajectories.

Boulton et al. (1992) compared the rates and directions of benthic aquatic invertebrate succession following flash floods of varying magnitude among seasons in a desert stream in Arizona, U.S. over a 3 yr period. Several flash floods occurred each year, but the interval between floods was long relative to the life spans of the dominant fauna. Invertebrate assemblage structure changed seasonally but was highly resistant and resilient to flooding disturbance, i.e., displacements resulting from flooding were less than were seasonal changes. By summer, robust algal mats supported dense invertebrate as-

semblages that were resistant to flooding disturbance. By fall, disruption of this algal mat made the associated invertebrate community more vulnerable to flooding disturbance. Assemblages generally returned to pre-flood structure, although trajectories varied widely. Long-term community structure was relatively consistent, despite unpredictable short term changes.

Van Langevelde et al. (2003) proposed a model of African savanna dynamics in which alternate vegetation states cycle over time, as a result of the interactive effects of fire and herbivory. Positive feedback between grass biomass and fire intensity is disrupted by grazing, which reduces fuel load, fire intensity, and tree mortality. Increased woody vegetation causes a change in state from grass dominance to tree dominance. Browsers respond to increased tree abundance, reducing woody biomass and stimulating grass growth, causing the cycle to repeat. Such a system may be relatively stable over long time periods but will appear unstable over short transition periods.

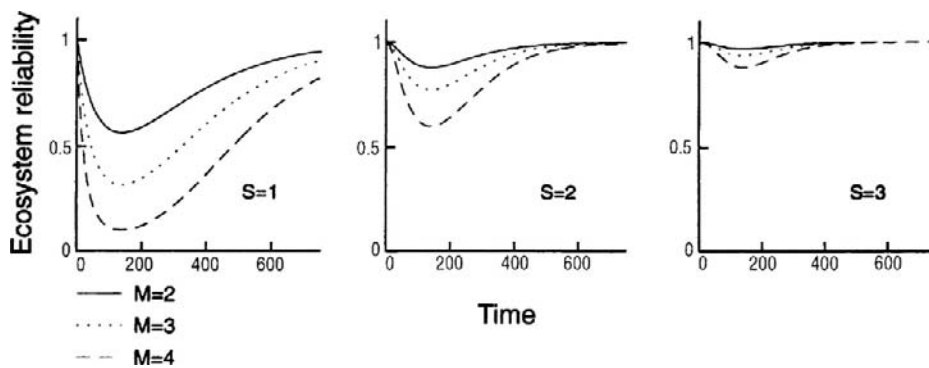
Although individual patches may change dramatically over time, or recover to variable endpoints, the dynamic mosaic of ecosystem types (e.g., successional stages or community types) at the landscape or watershed scale may stabilize the proportional area represented by each ecosystem type (Leibold and Mikkelsen 2002, Presley et al. 2010, J. Zimmerman et al. 2010, see Chapter 10). Changing land use practices have disrupted this conditionally-stable heterogeneity of patch types at the landscape scale.

Finally, the time frame of stability must be considered within the context of the ecosystem. For example, forests appear to be less stable than grasslands because of the long time period required for recovery of forests to pre-disturbance conditions, compared to rapid refoliation of grasses from surviving underground rhizomes. However, forests typically are disturbed less frequently. Net primary production may recover to pre-disturbance levels within 2–3 yrs, although biomass requires longer periods to reach pre-disturbance levels (e.g., Boring et al. 1988, Scatena et al. 1996, J. Zimmerman et al. 1996).

## D. Regulation of NPP by Biodiversity

The extent to which biodiversity contributes to ecosystem stability has been highly controversial (e.g., Hooper et al. 2005, see Chapter 10). Different species have been shown to control different aspects of ecosystem function, e.g., production, decomposition, and nutrient fluxes, demonstrating that biodiversity in its broadest sense affects ecosystem function (Beare et al. 1995, Hättenschwiler and Gasser 2005, Spehn et al. 2005, Vitousek and Hooper 1993, Waide et al. 1999, Woodwell 1993). The presence or absence of individual species, especially keystone species, affects biotic, atmospheric, hydrospheric, and substrate conditions (e.g., Downing and Leibold 2002). However, relatively few species have been studied sufficiently, under different conditions, to evaluate their effects on ecosystem functions. The debate depends, to a large extent, on definitions and measures of stability (see above) and of diversity (see Chapter 9).

Vitousek and Hooper (1993) suggested that the relationship between biodiversity and ecosystem function could take several forms. Their Type 1 relationship implies that each species has the same effect on ecosystem function. Therefore, the effect of adding species to the ecosystem is incremental, producing a line with constant slope. The Type 2 relationship represents a decreasing and eventually disappearing effect of additional species, producing a curve that approaches an asymptote. The Type 3 relationship indicates no further effect of additional species.



**FIG. 15.4** Ecosystem reliability over time as a function of the number of functional groups ( $M$ ) and number of species per functional group ( $S$ ), for a probability of species colonization over time of 0.005 and a probability of species presence over time of 0.005. From Naeem (1998) with permission from John Wiley & Sons.

Communities are not random assemblages of species but, rather, functionally-linked groups of species. Therefore, the Type 2 relationship probably represents most ecosystems, with additional species contributing incrementally to ecosystem function and stability until all functional groups are represented (Vitousek and Hooper 1993). Further additions have progressively smaller effects, as species packing within functional groups simply redistributes the overall contribution among species. Hence, ecosystem function is not linearly related to diversity (Waide et al. 1999), but increased diversity within functional groups provides insurance against loss of individual species.

Within-group diversity could affect the persistence or sustainability of a given function, more than its rate or regulation, and thereby increase the reliability of that function (Fig. 15.4) (Naeem 1998, Naeem and Li 1997, Spehn et al. 2005). Tilman et al. (1997) reported that both plant species diversity and functional diversity significantly influenced six ecosystem response variables, including primary productivity and nitrogen pools in plants and soil, when analyzed in separate univariate regressions, but that only functional diversity significantly affected these variables in a multiple regression. Hooper and Vitousek (1997) also found that variability in ecosystem parameters was significantly related to the composition of functional groups, rather than their number, further supporting the concept of complementarity among species or functional groups. Fukami et al. (2001) investigated the mathematical relationship between such compartmentalized biodiversity and ecosystem stability. They concluded that biodiversity loss reduces similarity in species composition among local communities and thereby reduces the reliability (stability) of continued ecosystem processes.

The dominant organisms in any ecosystem are adapted to survive environmental changes or disturbances that recur regularly with respect to generation time. Therefore, adaptation to prevailing conditions (evolution) constitutes a feedback that reduces ecosystem deviation from nominal conditions. For example, many grassland and pine forest species are adapted to survive the low intensity fires and drought (e.g., underground rhizomes and insulating bark, respectively) that characterize these ecosystems, thereby stabilizing vegetation structure and primary production. Nevertheless, the dominant species are not necessarily most important for maintenance of ecosystem function or stability (Hooper et al. 2005). Rare species, such as top predators, may function as keystone species to maintain diversity and stability. Diverse communities may be more

resistant to spread of host-specific insects or pathogens, or to invasive species (Hooper et al. 2005, see Chapter 6). However, the spread of generalists may increase with diversity, where diversity ensures a greater proportion of hosts (Ostfeld and Keesing 2000).

All ecosystems are subject to periodic catastrophic disturbances and subsequent community recovery through species replacement (succession). Ecosystem diversity at large spatial or temporal scales may buffer the ecosystem from disturbance or provide the species pool for reestablishment of key species from neighboring patches or seed banks (Hooper et al. 2005, Reusch et al. 2005). The rapid development of early successional communities limits the loss of ecosystem assets, especially soil and limiting nutrients. Hence, succession represents a mechanism for reducing deviation in ecosystem parameters, but some early- or mid-successional stages are capable of inhibiting further succession. Herbivores may be instrumental in facilitating replacement of inhibitive successional stages under suitable conditions (Chapter 10).

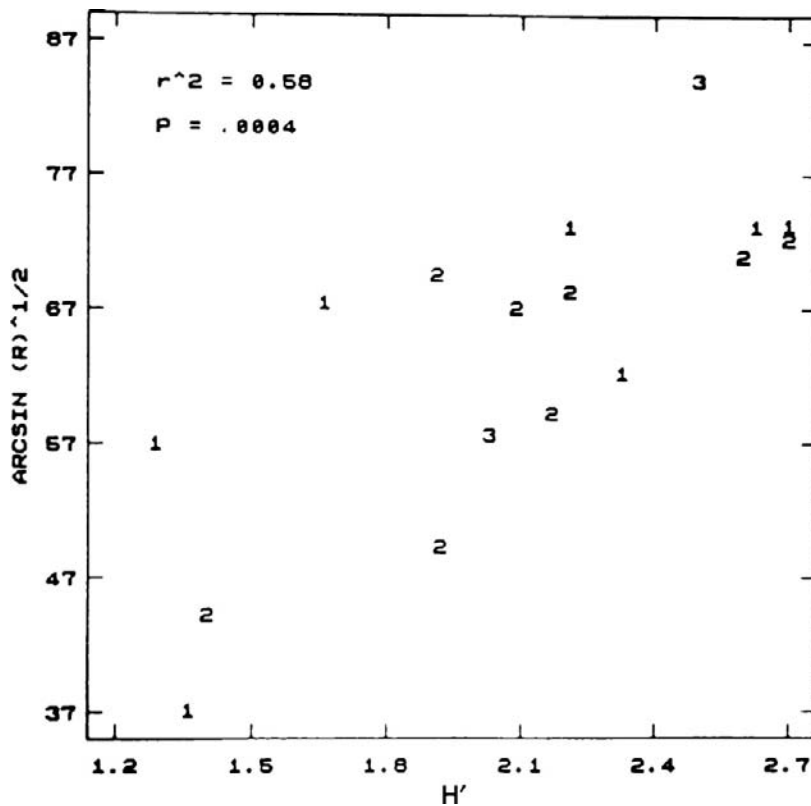
Few studies have measured the effect of biodiversity on the stability of ecosystem parameters. Most are based on selection of plots that differ in plant species diversity and, therefore, are potentially confounded by other factors that could have produced differences in diversity among plots.

McNaughton (1985, 1993b) studied the effect of plant species diversity on the persistence and productivity of biomass in grazed grasslands in the Serengeti Plain in East Africa. Portions of areas differing in plant diversity were fenced to exclude ungulate grazers. Stability was measured as both resistance (change in productivity resulting from grazing) and resilience (recovery to fenced control condition following cessation of grazing). Grazing reduced diversity by 27% in more diverse communities but had no effect on less diverse communities. The percentage biomass eaten was 67% and 76% in the more and less diverse communities, respectively, a non-significant difference. By 4 weeks after the cessation of grazing, the more diverse communities had recovered to 89% of control productivity, but the less diverse communities recovered to only 31% of control productivity, a significant difference.

McNaughton (1977, 1993b) also compared the resistance of adjacent grasslands of differing diversities to environmental fluctuation. Stability, measured as resistance to deviation in photosynthetic biomass, increased with diversity. This resulted from compensation between species with rapid growth following rain, but rapid drying between showers, and species with slower growth after showers, but slower drying between showers. Eight of ten tests demonstrated a positive relationship between diversity and stability (McNaughton 1993b).

D. Frank and McNaughton (1991) similarly compared effects of drought on plant species composition among communities of differing diversities in Yellowstone National Park in the western U.S. Stability of species composition to this environmental change was strongly correlated to diversity (Fig. 15.5).

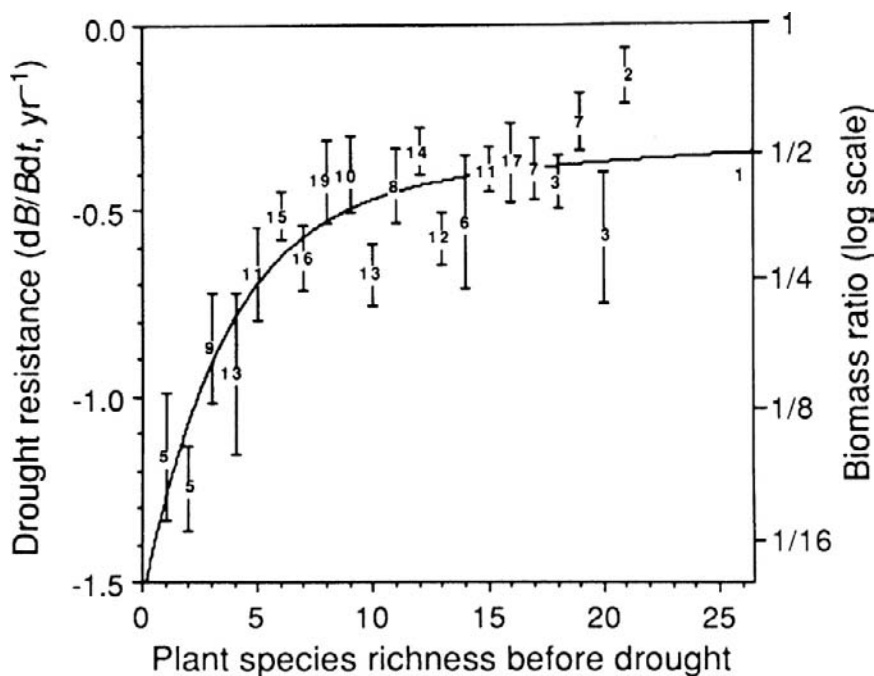
Ewel (1986) and Ewel et al. (1991) evaluated the effects of experimental manipulation of plant diversity on biogeochemical processes in a tropical rain forest in Costa Rica. This study included five treatments: a diverse natural succession, a modified succession with the same number and growth form of successional species but no species in common with natural succession, an enriched species diversity with species added to a natural succession, a crop monoculture (replicates of three different crop species), and bare ground (vegetation-free). After five years this design yielded plots with no plants (vegetation-free), single species (monoculture), > 100 species (natural and modified succession), and 25% more species (enriched succession). Elemental pool sizes were always significantly



**FIG. 15.5** Relationship between stability (measured as resistance ( $R$ ) to change in species abundances, in degrees) and diversity ( $H'$ ) in grasslands subject to grazing and drought at Yellowstone National Park, Wyoming. 1=early season, ungrazed, 2=peak season, grazed, 3=peak season, ungrazed. From D. Frank and McNaughton (1991) with permission from John Wiley & Sons.

larger in the more diverse plots, reflecting a greater variety of mechanisms for retention of nutrients and maintenance of soil processes favorable for plant production. The results suggested a Type 2 relationship between biodiversity and stability, with most change occurring at low species diversity. However, the absence of intermediate levels of diversity, between the monoculture and > 100 species treatments, limited interpolation of results.

In 1982 Tilman and Downing (1994) established replicated plots in which the number of plant species was altered through different rates of nitrogen addition. These plots subsequently (1987–1988) were subjected to a record drought. During the drought, plots with > 9 species averaged about half of their pre-drought biomass, but plots with < 5 species averaged only about 12% of their pre-drought biomass (Fig. 15.6). Hence, the more diverse plots were better buffered against this disturbance because they were more likely to include drought-tolerant species, compared to less diverse plots. The more diverse plots also recovered biomass more quickly following the drought. When biomass was measured in 1992, plots with  $\geq 6$  species had biomass equivalent to pre-drought levels, but plots with  $\leq 5$  species had significantly lower biomass, with deviations of 8–40% (Fig. 15.7). Tilman and Downing (1994) and Tilman et al. (1997) concluded that more diverse ecosystems represented a greater variety of ecological strategies, which confer both greater resistance and greater resilience to environmental variation. However, the contribution of diversity

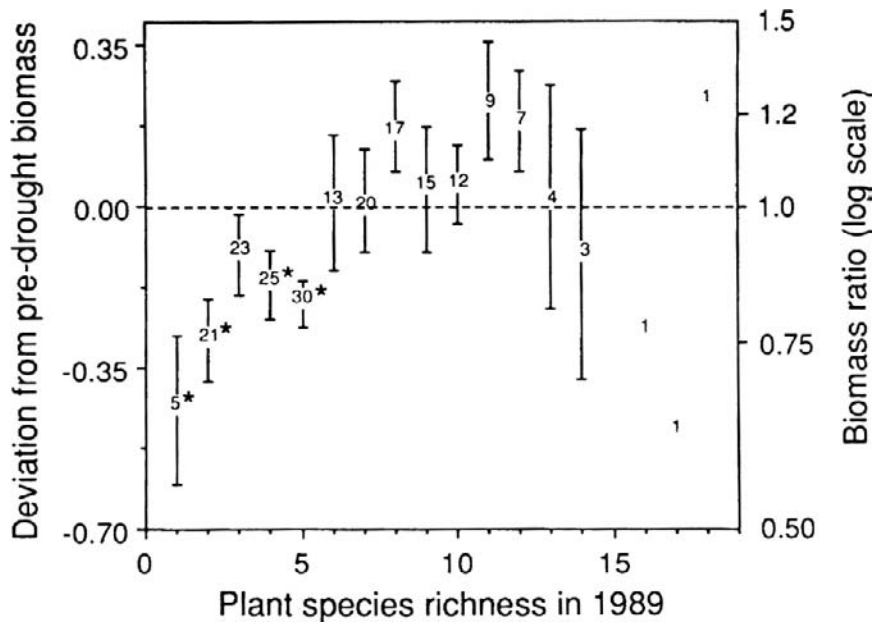


**FIG. 15.6** Relationship between plant species diversity prior to drought and drought resistance in experimental grassland plots planted with different species diversities. Mean, standard error and number of plots with given species richness are shown.  $1 \text{ dB/Bdt (yr}^{-1}\text{)} = 0.5 \ln(1988 \text{ biomass}/1986 \text{ biomass})$ , where 1988 was the peak drought year and 1986 was the year preceding drought. The biomass 1988/1986 ratio (right-hand scale) indicates the proportional decrease in plant biomass associated with dB/Bdt values. From Tilman and Downing (1994) with permission from Nature, © 1994 Macmillan Magazines, Ltd.

to ecosystem stability may be related to environmental heterogeneity, i.e., diversity does not necessarily increase stability in more homogeneous environments.

Spehn et al. (2005) manipulated plant diversity in multiple European grassland ecosystems. They found that the more diverse communities were more productive and utilized resources more completely, through their greater occupation of available space and uptake and retention of nitrogen, than did less diverse communities. Reusch et al. (2005) demonstrated that experimentally increased genotypic diversity of a common seagrass, *Zostera marina*, enhanced biomass production, plant density and faunal abundances, buffering the coastal community against extreme temperatures.

A number of studies have demonstrated that ecosystem resistance to elevated herbivory or plant disease is positively correlated to vegetation diversity (e.g., Garrett and Mundt 1999, M. T. Johnson et al. 2006, Knops et al. 1999, McNaughton 1985, Schowalter and Lowman 1999, Schowalter and Turchin 1993, Chapters 6 and 7). As vegetation diversity increases, relative to the host range of any particular herbivore, the ability of herbivores to find and exploit their hosts decreases (Jactel and Brockerhoff 2007), leading to increasing stability of herbivore–plant interactions. Even genetic variation in a dominant plant species can affect herbivory (Hochwender and Fritz 2004, M. T. Johnson et al. 2006, Wimp et al. 2007).



**FIG. 15.7** Relationship between plant species diversity and deviation in 1992 biomass (following drought) from mean (1982–86) pre-drought biomass in experimental grassland plots planted with different species diversities. Mean, standard error and number of plots with given species richness are shown. Negative values indicate 1992 biomass lower than pre-drought mean. Biomass ratio is biomass 1992/pre-drought. Plots with 1, 2, 4 or 5 species (but not plots with > 5 species) differed significantly from pre-drought means. From Tilman and Downing (1994) with permission from Nature, © 1994 Macmillan Magazines, Ltd.

Experimental studies which relate ecosystem stability to diversity generally have been limited to manipulation of plant species diversity (Hooper et al. 2005, Spehn et al. 2005). However, insects represent the bulk of diversity in virtually all ecosystems (e.g., Table 9.1) and are capable of controlling a variety of ecosystem conditions (Chapters 12–14). A few studies have addressed the significance of diversity at higher trophic levels to ecosystem processes, but not to ecosystem stability (Downing and Leibold 2002, Laakso and Setälä 1999, Lewinsohn and Price 1996).

B. Klein (1989) found that the diversity of dung beetles (Scarabaeidae) and the rate of dung decomposition were positively correlated to the size of forest fragments in central Amazonia. However, abiotic conditions that also affect decomposition probably differed among fragment sizes, as well. Larsen et al. (2005) discovered that dung burial rate increased with the diversity of dung beetle species that were retained among islands created by construction of a hydroelectric dam in Venezuela. Furthermore, absence of some species caused a greater reduction in dung burial rate than did absence of others, indicating that species composition is as important as richness.

Coûteaux et al. (1991) manipulated diversity of decomposer communities in microcosms with ambient or elevated concentrations of  $\text{CO}_2$ . They found that decomposition and respiration rates were significantly related to decomposer diversity, as affected by species shifts following  $\text{CO}_2$  treatment. This study demonstrated an effect of biodiversity on rates of a key ecosystem process, but did not address the long-term stability of this process.

Downing and Leibold (2002) evaluated the effects of manipulated species composition nested within multi-trophic diversity treatments in pond mesocosms. The effect of species composition on productivity, respiration and decomposition was equivalent to, or greater, than the effect of diversity *per se*. Productivity was highest in the highest diversity treatments.

Herbivore and predator diversities have not been experimentally manipulated in terrestrial ecosystems to evaluate the effect of diversity at these levels on processes at lower trophic levels, except for biological control purposes, which may not represent interactions in natural ecosystems. For example, McEvoy et al. (1993) manipulated the abundances of two insect species with complementary feeding strategies (cinnabar moth, *Tyria jacobaeae*, a foliage and inflorescence feeder, and ragwort flea beetle, *Longitarsus jacobaeae*, a root-feeder). These species had been introduced to control the exotic ragwort, *Senecio jacobaea*, in coastal Oregon, U.S. Their results indicated that increasing diversity (from no herbivores to one herbivore to both herbivores) decreased the local stability of the herbivore–plant interaction, as increasing herbivory drove the host to local extinction, at the plot scale. However, this plant species persisted at low densities over the landscape, suggesting that the interaction is stable at larger spatial scales. Croft and Slone (1997) reported that European red mite, *Panonychus ulmi*, abundances in apple orchards were maintained at lower, equilibrial, levels by three predaceous mite species in combination than by any single predaceous species. Letourneau et al. (2009) conducted a meta-analysis of studies on the effects of predator diversity on herbivores and concluded that increased predator diversity generally increased the top–down regulation of herbivore populations.

Ultimately, the capacity of ecosystems to endure or modify the range of environmental conditions is the primary measure of stability (Hooper et al. 2005) (Fig. 15.4). In this regard, Boucot (1990) noted that the fossil record demonstrates that characteristic species assemblages (hence, ecosystems) often have persisted for many thousands of years over large areas. Furthermore, studies of current ecosystems must account for departure of ecosystem conditions from pre-anthropogenic conditions, including adjustments for altered climate, disturbance regime, and invasive species.

### E. Regulation of NPP by Insects

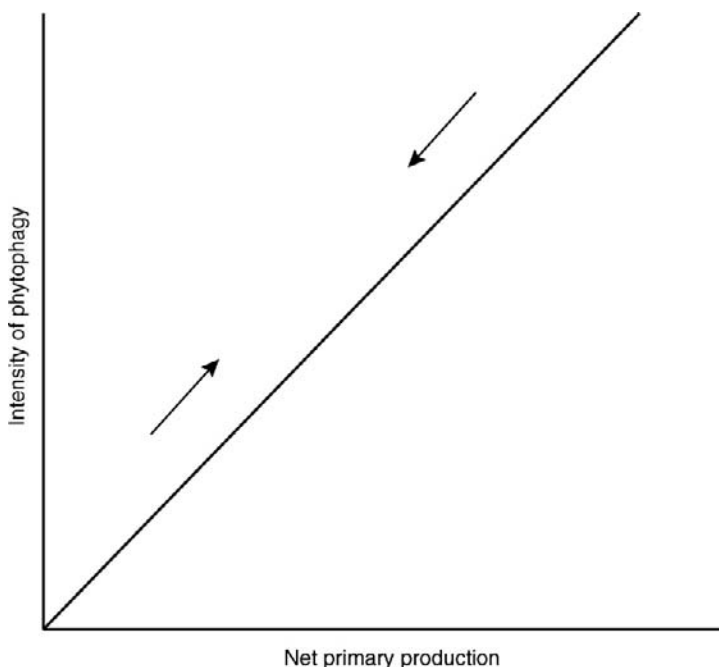
Mattson and Addy (1975) introduced the hypothesis that phytophagous insects regulate primary production, based on observations that herbivory that is focused on dense and/or stressed host plants functions in a density-dependent manner similar to predation. Schowalter (1981) proposed that herbivore outbreaks, triggered by host stress and density as resources become limiting, advance succession from communities with high demands for resources to communities with lower demands. Davidson (1993) and Schowalter and Lowman (1999) refined this hypothesis by noting that herbivores and granivores can advance, retard, or reverse succession, depending on environmental conditions. Belovsky and Slade (2000) demonstrated that grasshoppers can accelerate nitrogen cycling and increase primary productivity, especially by plants that are better competitors when nitrogen is more available, at intermediate levels of herbivory. At low levels of herbivory, grasshoppers had too little influence on nitrogen cycling to affect primary production, and at high levels grasshoppers depressed plant growth and survival more than could be offset by increased nitrogen cycling and plant productivity.



Despite the obvious influence of animals on key ecosystem processes, their regulatory role has remained controversial and largely untested. Herbivorous insects possess the characteristics of cybernetic regulators (i.e., low maintenance cost and rapidly amplified effects, sensitivity to deviation in ecosystem parameters, and capacity to alter primary production dramatically through positive and negative feedback) and appear, in many cases, to stabilize net primary production. For example, the inconsequential biomass of phytophagous insects, even at outbreak densities, is capable of removing virtually all foliage from host plants and altering plant species composition (see Chapter 12). The virtually undetectable biomass of termites accounts for substantial decomposition, soil redistribution, and gas fluxes that could affect global climate (see Chapter 14). The following model for the effect of insects on ecosystem stability focuses on herbivores, but detritivores, pollinators and seed dispersers are also capable of modifying ecosystem conditions in ways that might promote stability, e.g., decomposer enhancement of nutrient availability, plant growth and herbivory (Holdo and McDowell 2004) as feedback on herbivore effects on litter quality and availability (S. Chapman et al. 2003, Whitham et al. 2006).

Primary production often peaks at low-to-moderate intensities of pruning and thinning (Fig. 12.5), which often are used to increase commodity production, supporting the grazing optimization hypothesis (Belovsky and Slade 2000, S. Williamson et al. 1989). Herbivores can stimulate primary production at low levels of herbivory, when host density is low or condition good, and reduce host production at high levels, when host density is high or condition poor (Fig. 15.8), thereby potentially stabilizing primary production at intermediate levels (e.g., Alfaro and Shepherd 1991, Romme et al. 1986). Elevated primary productivity following outbreaks suggests the alleviation of stressful conditions (that triggered the outbreak and could lead to instability) but also reflects greater species turnover as stressed hosts are replaced by species that are better able to tolerate prevailing conditions (J. Chase et al. 2000, Belovsky and Slade 2000, Ritchie et al. 1998). By stabilizing primary production, herbivores also stabilize processes controlled by primary production, including climate and soil conditions, biogeochemical fluxes, etc., that affect the survival and reproduction of associated organisms. Romme et al. (1986) reported that mountain pine beetle, *Dendroctonus ponderosae*, outbreaks appeared to increase the variation (destabilization) of some ecosystem properties, but some stands recovered pre-outbreak NPP within ten years after the outbreak. Significantly, these outbreaks represented a biotic response to an anthropogenic deviation in primary production, i.e., increased tree density resulting from fire suppression. As outlined in the opening of this chapter, insect outbreaks often reverse anthropogenic increases in host density and return the ecosystem to conditions that prevailed prior to anthropogenic change (Schowalter 2008).

Outbreaks of phytophagous insects are most likely to occur under two interrelated conditions, both of which represent a departure from nominal ecosystem conditions that often reflects anthropogenic change (Schowalter 1985, Schowalter and Lowman 1999). First, adverse environmental conditions, such as inadequate water or nutrient availability, changing climate, and atmospheric pollution, stress plants and cause changes in physiological conditions that increase suitability for phytophages (see Chapters 2 and 3). High intensities of herbivory under these conditions generally reduce biomass and improve water or nutrient balance (Kolb et al. 1999) or, in extreme cases, reduce biomass of the most stressed plants, regardless of their abundance, and promote replacement by better adapted plants (e.g., J. Chase et al. 2000, Ritchie et al. 1998, Schowalter and Lowman 1999). Second, high densities of particular plant species, as a result of rapid colonization by pioneer species or artificial planting, enhance host availability for associ-



**FIG. 15.8** Stimulation of primary production at  $NPP < K$  and suppression of primary production at  $NPP > K$  by phytophages (see Fig. 12.5) could stabilize primary production. From Schowalter (2000) with permission from CAB International, Wallingford, UK.

ated phytophages. High intensities of herbivory represent a major mechanism for reversing site dominance by such plant species (Schowalter 2008, Torres 1992), facilitating their replacement and increasing plant diversity.

If communities evolve to minimize environmental variation, then herbivore interactions with disturbances are particularly important. Although outbreaks of herbivores traditionally have been viewed as disturbances (together with events such as fire, storm damage and drought), their response to host density or stress often appears to reduce the severity of abiotic disturbances. Herbivore outbreaks commonly are induced by drought conditions (Mattson and Haack 1987, T. White 1969, 1976, 1984), suggesting that plant moisture stress may be a particularly important trigger for the feedback responses that reduce transpiration and improve water balance (Kolb et al. 1999, W. Webb 1978). Fuel accumulation, as a result of herbivore-induced fluxes of material from living to dead biomass, often predisposes ecosystems to fire in arid environments. Whether such predisposition is stabilizing or destabilizing depends on the degree to which outbreaks modify the severity and temporal or spatial scale of such disturbances. Schowalter (1985) and Schowalter et al. (1981a) suggested that herbivore-induced disturbances might occur more regularly with respect to host generation times or stages of ecosystem development, as a result of specific plant–herbivore interactions, and thereby facilitate rapid adaptation to disturbance or post-disturbance conditions. Although such induction of disturbance would seem to increase variation in the short term, accelerated adaptation would contribute to stability over longer time periods. Furthermore, the increased likelihood of disturbance during particular seres should maintain that sere on the landscape, contributing to stability over larger spatial scales. The following example

demonstrates the potential stabilization of ecosystem properties over the large spatial scales of western North America.

Conifer forests dominate much of the montane and high latitude region of western North America. The large, contiguous, lower elevation zone is characterized by relatively arid conditions and frequent droughts that historically maintained a sparse woodland dominated by drought- and fire-tolerant (but shade-intolerant) pine trees and a ground cover of grasses and shrubs, with little understory (Fig. 15.9a). Low intensity ground fires occurred frequently, at intervals of 15–25 yrs, and covered large areas (Agee 1993), minimizing drought-intolerant vegetation and litter accumulation. The relatively isolated, higher elevation and riparian zones were more mesic and supported shade-tolerant (but fire- and drought-intolerant) fir and spruce forests. Fire was less frequent (every 150–1000 yrs), but more catastrophic, at these elevations as a result of the greater tree densities and understory development that conveyed fire into tree canopies (Agee 1993, Veblen et al. 1994).

As a result of fire suppression during the past century, much of the lower elevation zone has undergone succession from pine forest to later successional fir forest (Fig. 15.9b), with greatly increased plant biomass, a conspicuous deviation from historic conditions. Outbreaks of a variety of folivore and bark beetle species have become more frequent in these altered forests. During mesic periods and in more mesic locations, e.g., riparian corridors and higher elevations, the mountain pine beetle has advanced succession by facilitating the replacement of competitively-stressed pines by more competitive firs. However, during the inevitable drought periods, such as occurred during the 1980s, mois-



**FIG. 15.9** The relatively arid interior forest region of North America was characterized by open-canopied forests dominated by drought- and fire-tolerant pines, with sparse understories, prior to fire suppression beginning in the late 1800s (left). Fire suppression has transformed forests into dense, multistoried ecosystems stressed by competition for water and nutrients (right). From Goyer et al. (1998) with permission from the Society of American Foresters.

ture limitation increases the vulnerability of stressed firs to herbivores (Fig. 15.10). Insect-induced mortality of the firs reversed succession, by favoring the remaining drought- and fire-tolerant pines. Tree mortality can increase the severity and scale of catastrophic fires, that historically were rare in these forests, unless litter decomposition reduces fuel accumulation before fire occurs. However, this altered fire regime may be mitigated in ecological time by the eventual re-establishment of the pine sere following catastrophic fire. A similar situation has been inferred from insect demography in pine-hardwood forests of the southern U.S. (Fig. 10.6). Van Langevelde et al. (2003) also suggested a cycle of alternating vegetation states maintained by interaction of fire and herbivores in the African savanna.

To what extent do insects contribute to stability and “health” of various ecosystems? Until recently, insect outbreaks and disturbances have been viewed as destructive forces. The increased productivity of ecosystems in the absence of fire and insect outbreaks supported a view that resource production could be freed from the limitations imposed by these regulators. However, fire now is recognized as an important tool for restoring sustainable (stable) ecosystem conditions and characteristic communities. The outbreak in the example above caused devastating losses in timber production over the short-term, and required an emergency salvage harvest to prevent pre-market wood degradation. However, the insect outbreak effectively reversed anthropogenic change in this forest, producing a more historic forest structure that is the recommended management goal for Sierran forests (North et al. 2007). From this perspective, the outbreak contributed to the stability of this forest. To the extent that native insect herbivores maintain ecosystem structure and function within historic ranges of variability, contributing to sustained (long



**FIG. 15.10** *Herbivore* modification of succession in central Sierran mixed conifer ecosystems during 1998. Understory white fir (*Abies concolor*), the late successional dominant, is increasingly stressed by competition for water in this arid forest type. An outbreak of the Douglas-fir tussock moth, *Orgyia pseudotsugata* has completely defoliated the white fir (brown trees), restoring the ecosystem to a more stable condition dominated by earlier successional, drought- and fire-tolerant, sequoias and pines (green trees).

term) rather than maximum (short term) primary production, control of outbreaks might not contribute to ecosystem services.

Regulation of primary production by phytophagous insects could stabilize other ecosystem variables, as well. Clearly, experimental studies should address the long-term effects of phytophagous insects on variability of ecosystem parameters. Our management of ecosystem resources, and in particular our approach to managing phytophagous insects, requires that we understand the extent to which herbivores contribute to ecosystem stability. To the extent that insect outbreaks reflect stabilizing feedback, suppression could be counterproductive.

### III. SUMMARY

The hypothesis that phytophagous insects regulate ecosystem processes is one of the most important and controversial concepts to emerge from research on insect ecology. The extent to which ecosystems are random assemblages of species that simply affect ecosystem processes or are tightly co-evolved groups of species that stabilize ecosystem function has important implications for the management of ecosystem resources and of “pests”. Concepts of group selection have developed from and contributed to this hypothesis.

Debate on the issue of group selection has solidified consensus on the dominance of direct selection for individual attributes. However, individual attributes affect other organisms and environmental conditions that generate feedback on individual fitness. Such feedback selection contributes to the inclusive fitness of an individual. The intensity of this feedback is proportional to the relatedness of interacting individuals. The greatest feedback selection is between individuals sharing genes (kin selection). The frequency of interaction and the intensity of feedback selection decline as interacting individuals become less related. However, frequent interspecific interaction can lead to negative feedback (e.g., competition and predation) and reciprocal cooperation (mutualism), based on the trade-off between gain or loss to each individual from such interaction.

Homeostasis at supra-organismal levels depends only in part on selection for attributes that benefit assemblages of organisms (i.e., group selection). The critical issue is the trade-off required to balance individual sacrifice, if any, and inclusive fitness accruing from traits that benefit the group (e.g., ecosystem). Stabilization of environmental conditions through species interactions favors the survival and reproduction of the constituent individuals. Therefore, feedback selection over evolutionary time scales should select for species interactions that contribute to ecosystem stability and mutually assured survival.

Major challenges for ecologists include defining stability, i.e., which ecosystem properties are stabilized, what range of deviation is tolerated, and what temporal and spatial scales are appropriate levels for measurement of stability, and evaluating the effect of mechanisms, such as biodiversity and herbivory, that contribute to stability. Traditionally, stability has been viewed as constancy or recovery of species composition over narrow ranges of time and space. Alternative views include reliability of net primary production and biomass structure that affect the stability of internal climate and soil conditions, and biogeochemical pools and fluxes over larger ranges of time and space. Stability may be achieved, not at the patch scale, but rather at the landscape scale where conditional stability is achieved through relatively constant proportions of various ecosystem types.

The relationship of stability to diversity has been a major topic of debate. Some species are known to control ecosystem properties, and their loss or gain can severely affect the structure or function of the ecosystem. Furthermore, effects of different species often are

complementary, such that more diverse assemblages should be buffered better against changes in ecosystem properties in heterogenous environments. A few experimental manipulations of plant species diversity have shown that more diverse communities have lower variability in primary production than do less diverse communities.

Herbivorous insects have been identified as potentially important regulators of primary production, hence of the ecosystem variables which are controlled by primary production. These insects possess the key criteria of cybernetic regulators, i.e., small biomass, rapid amplification of effect at the ecosystem level, sensitivity to airborne or waterborne cues indicating ecosystem conditions, and stabilizing feedback on primary production and other processes. A low intensity of herbivory, under conditions of low densities or optimal condition of hosts, tends to stimulate primary production, whereas higher intensities, under conditions of high host density or stress, tend to reduce primary production. Clearly, this aspect of insect ecology has significant implications for our approaches to managing ecosystem resources and “pests”. Anthropogenic activities that disrupt ecosystem stability or regulatory mechanisms would threaten the ecosystem services on which we depend (Chapter 16).

This page intentionally left blank

# APPLICATIONS AND SYNTHESIS

THE PREVIOUS SECTIONS HAVE ADDRESSED INSECT ECOLOGY at the individual, population, community and ecosystem levels of organization. Resource acquisition and allocation by individuals (Section I) depend on population (Section II), community (Section III) and ecosystem conditions that also are influenced by individuals, as described in Section IV. Insects are involved in a particularly rich variety of feedbacks between individual, population, community and ecosystem levels as a consequence of their dominance and diversity in terrestrial and freshwater ecosystems and their sensitivity and dramatic responses to environmental changes. The hypothesis that insects are major regulatory mechanisms in homeostatic ecosystems has important ecological and management implications and warrants critical testing.

The importance of temporal and spatial scales is evident at each level of the ecological hierarchy. Individuals have a life span and range of occurrence, populations show temporal dynamics and dispersion patterns, communities and ecosystems are represented over larger temporal and spatial scales. In particular, ecosystem stability and its effect on component individuals traditionally has been evaluated at relatively small scales, in time and space, but larger scales are more appropriate. The dynamic mosaic of ecosystem types at the landscape or biome level is conditionally stable in its proportional representation of ecosystem types.

Insect ecology has major application to management of ecosystem services, including management of insects as they affect these services positively and negatively. This concluding section emphasizes application of insect ecology (Chapter 16) and summarizes and synthesizes the study of insect ecology (Chapter 17).



This page intentionally left blank

# Applications

## I. Ecosystem Services

- A. Provisioning Services
- B. Cultural Services
- C. Supporting Services
- D. Regulating Services
- E. Valuation of Ecosystem Services

## II. Integrated Pest Management

- A. Development of the IPM Concept
- B. Ecological Tactics for Managing Crop and Forest "Pests"
- C. Ecological Tactics for Managing Medical and Veterinary "Pests"
- D. Ecological Tactics for Managing Urban "Pests"

## III. Conservation/restoration Ecology

## IV. Invasive Species

## V. Indicators of Environmental Conditions

## VI. Summary

### Ecological principles solve the boll weevil problem

The cotton boll weevil, *Anthonomus grandis*, entered the U.S. from Mexico in 1892 (W. Hunter and Hinds 1904) and by 1922 had spread across the entire cotton-growing region of the southern U.S. (Showler 2009). At that time cotton was the primary crop in this largely agrarian region, but production plummeted following appearance of the weevil. For example, weevils destroyed the entire cotton crop of southwestern Alabama in 1913 (R.H. Smith 2007). The first year the boll weevil was found state-wide in Alabama (1917), cotton production fell by 70%, to 500,000 bales, from a high of 1.7 million bales in 1914 (R.H. Smith 2007).

Early efforts to control the weevil included picking and burning infested cotton squares, drowning weevils in kerosene, and a variety of home remedies, none of which improved cotton yields. Destroying all cotton residue following harvest in the fall and volunteer cotton in early spring did reduce weevil damage and was one of the earliest recommended control tactics (Howard 1896). Failed cotton crops caused land values to plunge, leading to bankruptcy and mass migration out of the region (Hardee and Harris 2003). However, cotton failure also led to diversification of crop production in the South and to a shift in cotton production to northern (and later western) regions where the weevil was unable to survive the colder winters.

Passage by Congress of the Smith-Lever Act of 1914 created the Cooperative Extension Service, a state-federal cooperative that supported hiring of entomologists to advise cotton growers. Calcium arsenate dust became available for weevil control in 1918. Initially, this was applied by hand as a dust, with no protection for the applicators. Following WWI, aeronautical

(Cont.)

technology combined with veteran pilots led to aerial application methods that could cover larger areas with lower exposure to applicators (creating the term “crop duster”). Among the first aerial application companies was Delta Air Services in N.E. Louisiana, which eventually became Delta Airlines.

Calcium arsenate application continued until the 1950s, when more effective chlorinated hydrocarbons became available after WWII. Initially, dichlorodiphenyltrichlorethane (DDT) was highly effective against the boll weevil. However, weevil populations in Louisiana were resistant to DDT by 1955 (Roussel and Clower 1957), and resistance was soon discovered in other areas. In addition, environmental research showed that these chemicals persisted in the environment and become more concentrated at higher trophic levels, leading to serious environmental concerns (R. Carson 1962).

During this period, organophosphates, such as methyl parathion and malathion (developed as nerve gases during WWII) were introduced as liquid insecticides. These compounds were highly toxic to both weevils and applicators (as well as other vertebrates) but were short-lived. During the 1970s, pyrethroids were introduced. These chemicals were also acutely toxic to insects, but had lower toxicity for vertebrates and low persistence. Frequent application (12–16 applications per season) of these compounds was required for control. In addition, growers became more dependent on insecticides to control boll weevils and relied less on cultural and other non-chemical options.

Increasing concern about environmental costs and fear that boll weevils would become resistant to newer insecticides, as they had to chlorinated hydrocarbons, led to the consideration of other options. Advances in understanding of weevil “diapause” (Brazzel and Newsom 1959) and pheromone communication (Tumlinson et al. 1969) suggested that targeting these key attributes, using a combination of tactics, could eliminate this pest. Starting in the mid-1970s, intensive crop monitoring with weevil pheromone bait trapped many weevils and indicated where they were most abundant, typically demes isolated by crop diversification. These more restricted sites were targeted for application of malathion, which was the most effective insecticide. These tactics were combined with mandated crop destruction soon after harvest to deprive weevils of late-season resources and overwintering sites.

By the mid-1990s, no yield losses to boll weevil were reported in Alabama for the first time since 1910 (R.H. Smith 2007). Furthermore, insecticide use was reduced from an average of 10–14 applications per season to 1–4 (R.H. Smith 2007). The last boll weevil in Alabama was reported in 2003 (R.H. Smith 2007). The boll weevil was largely eliminated from most other states in the southern U.S. by 2010.

This century-long experience with the boll weevil demonstrated three major points. First, boll weevil spread was facilitated by extensive cultivation of a previously rare host in a new region. Second, crop diversification in the South established a more stable economy and limited the spread of insects. A monument to the boll weevil was dedicated in Enterprise, Alabama in 1919 to recognize the weevil’s contribution to crop diversification and improved economy in Coffee County. Third, the successful removal of the boll weevil as a factor affecting cotton production was achieved ultimately through the application of ecological research to target critical stages in weevil life history.

## INTRODUCTION

INSECT ECOLOGY PROVIDES US WITH BASIC INFORMATION ON HOW insects interact with their environment. This information can be applied to methods that sustain resource production, human health, and even our global environment. Understanding of feedbacks between insects and our common environment, as described in Chapters 1–15, provides the basis for managing our interactions with insects in the broader context of ecosystem and global processes. In fact, as described in earlier chapters,

much of our knowledge of insect ecology, especially population dynamics and insect–plant and predator–prey interactions, has been gained from studies with more applied goals. Although insect outbreaks occur in natural ecosystems when conditions are favorable, anthropogenic activities have elevated a number of species to “pest” status. In particular, anthropogenic changes in ecosystem conditions have promoted population growth of many species, and transport of others has permitted spread into novel habitats. These changes often can be reversed or mitigated if we have adequate ecological information. However, any management decision should be based on consideration of trade-offs between costs and benefits of alternative strategies and the various, often complementary, effects of insects on multiple ecosystem services. Such information is necessary to determine when suppression of outbreaks may be warranted to sustain desired ecosystem services.

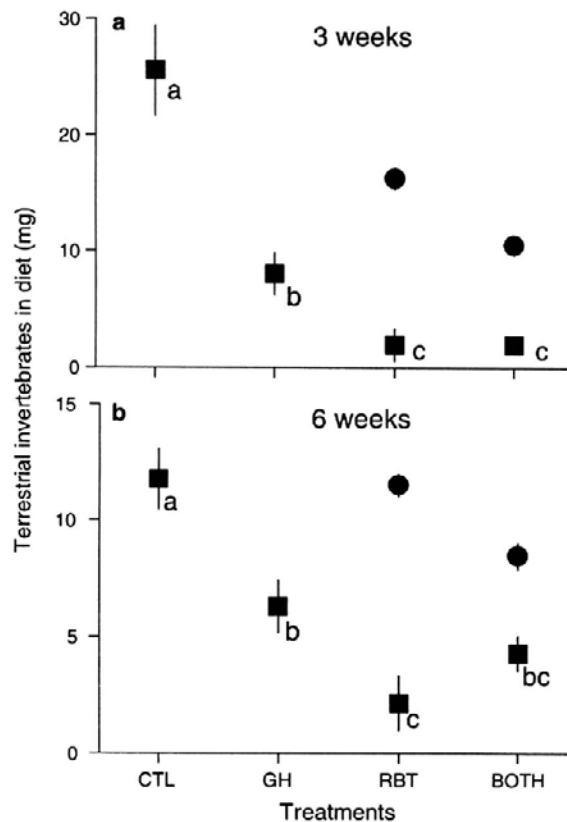
## I. ECOSYSTEM SERVICES

Natural ecosystems provide a variety of services on which humans, and other organisms, depend for survival and well-being. Ecosystem services can be categorized as **provisioning** (production of food, fiber, water and other resources), **cultural** (non-material benefits, such as recreation and other aesthetic values), **supporting** (primary production and soil formation necessary for resource production) and **regulating** (ecosystem processes which are critical to the sustainability of provisioning services) (Millennium Ecosystem Assessment 2005). The value of ecosystem services is difficult to assess because only provisioning and some cultural and supporting services have market values (Dasgupta et al. 2000), but global value has been estimated at US\$33 trillion annually (Costanza et al. 1997). Insects directly affect ecosystem services, especially during outbreaks. Effects may be positive or negative, depending on perspective, magnitude of effect and management goals.

### A. Provisioning Services

Ecosystems are the source of food, water, fiber, biofuels, and medical and industrial resources for humans. Many plants produce edible fruits, seeds or tubers, wood, fiber or other tissues that have become the basis for their cultivation as crop plants. Wildlife and fish are important food sources worldwide, and many of these animals feed primarily or exclusively on insects (Losey and Vaughan 2006). Insects falling into streams comprise 30–80% of the diets of young salmon (Fig. 16.1, J. Allan et al. 2003, Baxter et al. 2005, Kawaguchi and Nakano 2001). Woody materials are used for housing, furnishings, and fences, but also widely used for firewood. Phytochemicals provide important pharmaceutical compounds (e.g., Zenk and Juenger 2007), e.g., salicylic acid, morphine, quinine and epinephrin. Synthesis of complex compounds is often difficult or expensive, and exploration of natural resources continues for new medically-important materials (Helson et al. 2009). Many plant and animal products, including insects (see below), are widely used in traditional remedies. Some animals also use plant or other materials to remedy or prevent ailments (e.g., Mahaney et al 1999). Plant-derived tannins, resins, and other compounds are used in various industrial applications. Short-term losses in production of plant resources are obvious, and their economic value is easily measured and used to develop economic thresholds for pest control (Pedigo et al. 1986), but insect effects on fish and wildlife production may be largely positive.

Ecosystems are valued sources of fresh water, and adequate water supply is often the primary management goal for municipal watersheds. Insects falling into oligotrophic



**FIG. 16.1** Mean biomass of terrestrial invertebrates in diets of individual native Dolly Varden (*Salvelinus malma*, filled squares) and introduced rainbow trout (*Oncorhynchus mykiss*, filled circles) in treated reaches of Horonai Stream in Hokkaido, Japan after A) 3 weeks and B) 6 weeks during 2002. CTL=control (native Dolly Varden only), GH=greenhouse cover (to reduce subsidy of terrestrial invertebrates to stream), RBT=rainbow trout (non-native rainbow trout added), and BOTH=greenhouse cover and trout added. Values are means  $\pm$  1 SE ( $n=4$  except  $n=3$  for RBT treatment). Different letters indicate significant differences ( $P < 0.05$ ) among treatments within periods. From Baxter et al. (2007) with kind permission from the authors and Springer Science+Business media.

lakes and headwater streams add substantial amounts of carbon, nitrogen and phosphorus to these nutrient-poor ecosystems and affect aquatic community dynamics (Carlton and Goldman 1984, Mehner et al. 2005, Menninger et al. 2008, Nowlin et al. 2007, Pray et al. 2009). Herbivorous insects reduce canopy cover and increase the volume of precipitation reaching the ground and flowing into streams (Chapter 12). Soil and litter insects affect soil porosity and decomposition rate, factors that affect the rate of water movement through the substrate (Chapter 14). Changes in water yield and quality resulting from insect activity may or may not be desirable, depending on needs of downstream users.

Insects or their products are valuable ecosystem resources in many cultures. Honey has been among the most important commercial trade products for millennia. Honey production is often a major use of forests (Bradbear 2009), and ownership of forests with bee trees has included rights to revenue from honey harvest (Crane 1999). Honey or beeswax have

been preferred, or accepted, as payment for taxes, tolls, tithes and trade goods. Commercial honey production amounts to about US\$2 billion globally, with China accounting for 20% of the total production and 25% of world honey exports (J. Parker 2003). Honey has substantial antimicrobial activity against human pathogens (R. Cooper and Molan 1999, R. Cooper et al. 1999). Beeswax is used for candles, adhesives, seals, and molds for casting (e.g., the lost-wax method), and was sometimes a more important resource than honey (Crane 1999).

Grasshoppers, cicadas, caterpillars, beetles, and other insects are important sources of protein and revenue in many parts of the world (Cerritos and Cano-Santana 2008, Clausen 1954, DeFoliart 1999, Ramos-Elorduy 2009, Yen 2009). About 1500 edible insect species are consumed by 3000 ethnic groups in 113 countries (MacEvilly 2000). In some cultures, maintenance of edible insect populations represents a primary ecosystem management goal. Mbata et al. (2002) described the process for managing harvest of edible caterpillars (primarily two saturniids, *Gynanisa maja* and *Gonimbrasia zambesina*) in Zambian forests (Fig. 16.2). In one unique study, Cerritos and Cano-Santana (2008) reported that harvesting grasshoppers for food during an outbreak in Mexico substantially reduced grasshopper abundance and reproduction (Fig. 16.3) and provided US\$3,000 per family, compared to US\$150 for insecticide treatment had control tactics been implemented.

A number of insect species provide pharmaceutical compounds (Namba et al. 1988, Pemberton 1999), including cantharidin, a defensive alkaloid produced by blister beetles (Meloidae) that is used commercially to remove warts (Epstein and Kligman 1958). Use of ant mandibles to stitch wounds or surgical incisions was documented in India as early as 1000 B.C. and continued in some areas at least into the early 1900s (Gudger 1925). After live ants are induced to bite the pinched sides of a wound or incision, the ant bodies are removed, and the mandibles remain fastened until the wound heals (Gudger 1925). Blow fly (*Lucilia* spp.) maggots, used in traditional medicine to remove necrotic tissues without surgery, are receiving renewed medical attention for wound debridement, as surgical treatments increasingly risk infection by antibiotic-resistant pathogens (Kerridge et al. 2005, Sherman et al. 2000, 2007).

Insects also are a source of important industrial products. Silkworms remain the only source of silk. Silk production has been practiced at least since 2000–3000 B.C. in China and is among the most widely-traded commercial products. Its historic importance is demonstrated by the Silk Roads that connected Europe, the Middle-East, and China for at least 500 years, and by the introduction of the gypsy moth, *Lymantria dispar*, and other silk-producing species into North America and Europe in unsuccessful efforts to establish silk industries in the West (Andrews 1868, Anelli and Prischman-Voldseth 2009, Forbush and Fernald 1896, C. Riley and Howard 1890). Scale insects, especially *Dactylopius coccus*, are the source of cochineal dye, used by pre-Columbian civilizations as early as 2000 years ago and once the most valuable export from colonial Mexico, next to silver (Anelli and Prischman-Voldseth 2009, Greenfield 2005). Scale insects also were the principle source of commercial shellac (Clausen 1954) and remain a source of some shellac.

## B. Cultural Services

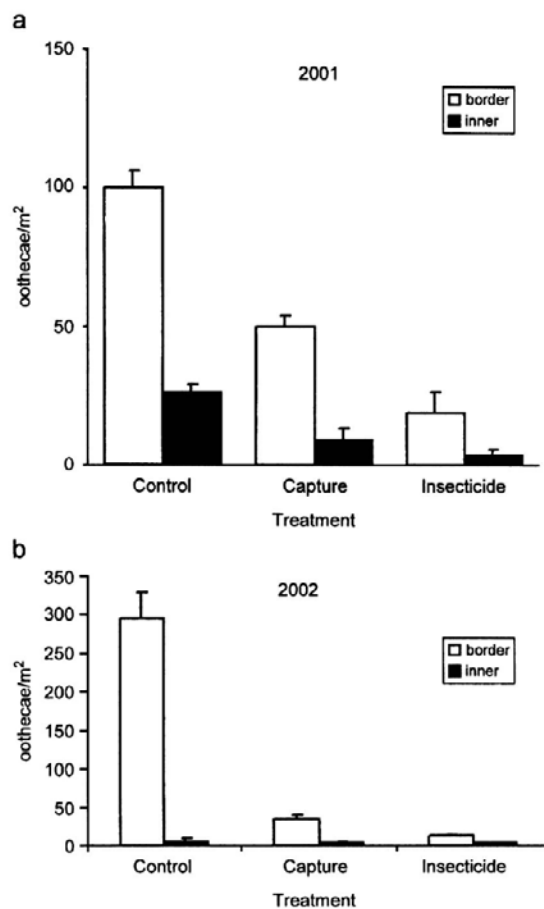
Ecosystems provide various religious, recreational and other cultural services, including hunting and fishing, wildlife observation, hiking and camping, educational and scientific pursuits and spiritual renewal. Most remnant forests in Ghana are sacred sites set aside by



**FIG. 16.2** Silkworm cocoon rattles worn by Zulu dancer in South Africa. Insects provide valued food and other resources in many cultures.

indigenous groups centuries ago and protected by religious sanctions and taboos (Bossart et al. 2006). The global value of recreational services (which can be calculated in part from usage fees) has been estimated at US\$815 billion by Costanza et al. (1997). Wildlife observation in the U.S. alone is valued at US\$34 billion annually, including an estimated US\$20 billion for observation of insect-dependent wildlife (Losey and Vaughan 2006).

Insect effects on cultural services can be positive or negative, depending on cultural perceptions. Ancient Egyptians considered scarab beetles to be symbols of eternal life and represented them widely in art and ornaments (Clausen 1954). Cicadas are symbols of rebirth in China, and cicadas and crickets often are caged and kept as pets for their songs (Clausen 1954). However, both are considered nuisances in some cultures.



**FIG. 16.3** Mean density of grasshopper, *Sphenarium purpurascens*, oothecae ( $\pm$ SE), in inner and border zones of alfalfa fields, by treatment (control, hand capture for human consumption, and insecticide) in the Puebla-Tlaxcala Valley of Mexico in 2001 a) and 2002 b). Reprinted from Cerritos and Cano-Santana, (2008) with permission from Elsevier.

Trees killed by insects can create safety hazards in recreational areas and may undermine spiritual value. Defoliation reduces shade and may be perceived as unsightly. Frass and tissues falling on people or eating surfaces are considered a nuisance by many and may be allergenic to some (Perlman et al. 1976). These effects can cause reduced visitation to recreational sites experiencing outbreaks.

Few studies have evaluated the effects of insects on cultural values. K. Downing and Williams (1978) reported that defoliation by a Douglas-fir tussock moth, *Orgyia pseudotsugata*, outbreak in Oregon did not significantly affect recreational use. Most visitors were aware of the outbreak, but few chose to avoid the outbreak area. The only negative effect was avoidance of salvage logging operations that were considered unappealing or hazardous for recreational use. On the other hand, extensive plant mortality may be viewed as unattractive or hazardous (Michalson 1975). Several studies have evaluated



preferences (measured as a visual-quality rating) among photographs showing different amounts and stages of defoliation or tree mortality due to insects (Hollenhorst et al. 1993, Leuschner 1980, S. Sheppard and Picard 2006). Generally, visual-quality rating is unaffected by participants' backgrounds, but shows relatively low thresholds (e.g., at 10–20% defoliation or mortality) above which visual-quality rating declines less steeply than at lower levels (S. Sheppard and Picard 2006).

### C. Supporting Services

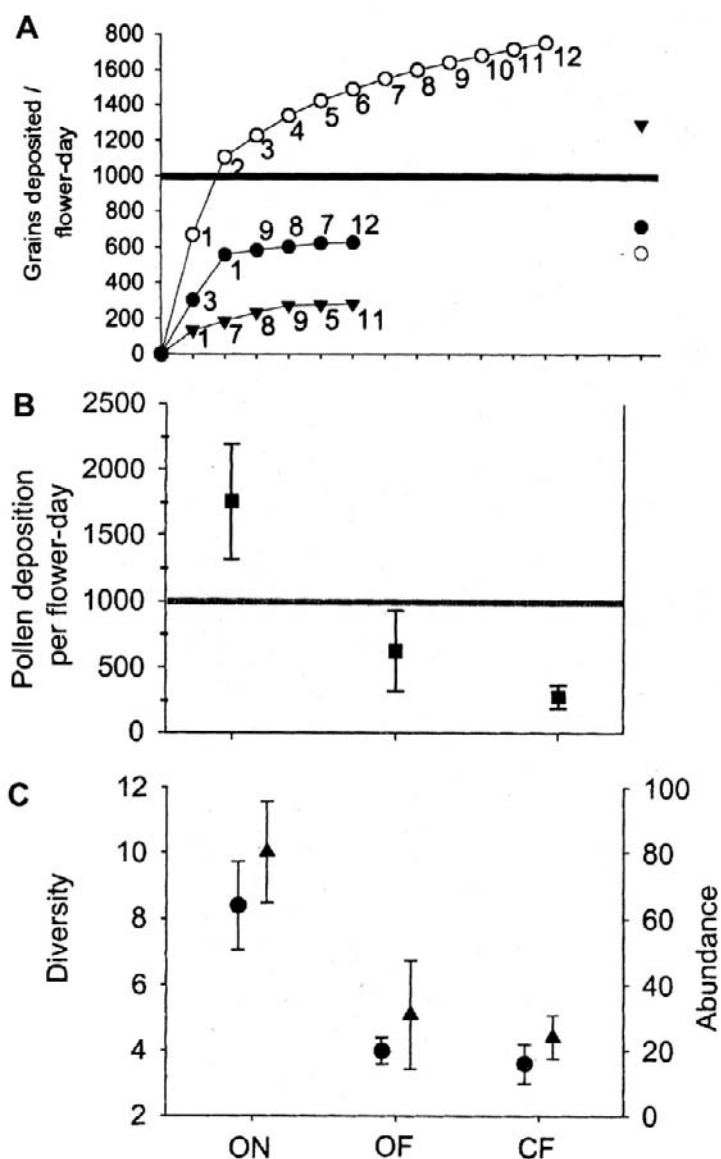
Supporting services include those ecosystem processes that are necessary for provisioning or cultural services, e.g., primary production, pollination, seed dispersal, soil formation and water filtration. Insects affect primary production, plant reproduction and soil formation in a number of ways, as described in Chapters 12–14. Disruption of these processes can impair ecosystem services, but long-term compensatory growth may offset short-term losses.

Pollination services are among the most widely valued roles of insects. Bees and other pollinators are necessary for pollination of 60–90% of plant species, and are responsible for 35% of global crop production (Kremen et al. 2007). Pollination of agricultural crops by honey bees is worth US\$117 billion per year globally (Costanza et al. 1997) and US\$8 billion per year in the U.S. (Isaacs et al. 2009). Native bee species also contribute substantially to pollination services and can, in some cases, provide full pollination service in the absence of honey bees (Fig. 16.4, Kremen et al. 2002). In Kenya, where > 99% of crop production is attributed to pollination by feral bees, the value of bee pollination represented nearly 40% of the annual US\$3.2 million in major crop production (Kasina et al. 2009). In the U.S., US\$12–16 billion per year in crop production was attributed to honey bees, and US\$3.1 billion per year to native bees (Losey and Vaughan 2006). However, sustainable reproduction of many non-crop plants that support native vertebrates and livestock and/or affect ecosystem conditions for other species also depends on a diversity of insect pollinators (R.H. Gibson et al. 2006, Vamosi et al. 2006, see Chapter 13). Threats to honey bee pollination services by invasive varroa mites, *Varroa destructor* and other parasites have generated widespread concern about the sustainability of many vegetable and fruit crops (see Chapter 13). Honey bees, an exotic species in much of the world, also have been blamed for losses of many native species that may be required for pollination of their mutualistic hosts (Aizen and Feinsinger 1994, G. Yang 2005, see Chapter 13).

Insects also affect soil structure and fertility (see Chapter 14). Dung beetles, in particular, provide a major agricultural service by burying livestock dung, thereby reducing forage fouling by dung accumulation, reducing nitrogen loss via volatilization and reducing livestock losses due to hematophagous flies (see Chapter 14). The infusion of organic matter into the soil contributes to its texture and water-holding capacity. The annual value of dung burial by dung beetles in the U.S. is estimated at US\$380 million (Losey and Vaughan 2006).

### D. Regulating Services

Regulating services include biotic controls on variation in biogeochemical fluxes, climate, etc. As described in Chapters 12 and 15, populations of native herbivores regulate primary production in a density-dependent manner, stimulating compensatory primary production at low-to-moderate levels of herbivory (when resource availability is adequate



**FIG. 16.4** Native bee contribution to pollination of watermelons in organic farms near semi-natural oak woodland and chaparral habitat (ON), organic farms isolated from semi-natural habitat (OF) and conventional farms isolated from semi-natural habitat (CF). A) estimated mean pollen deposition per flower-day ( $\pm$ SE) for native bees (numbered 1–12) and honey bees, *Apis mellifera*. Open circles = ON, filled circles = OF and filled triangles = CF, B) total estimated pollen deposition ( $\pm$ SE) by native bees in 2001. The horizontal line represents the pollen deposition threshold for production of marketable fruit. C) native bee diversity (circles) and abundance (triangles) in 2001 ( $\pm$ SE). From Kremen et al. (2002) with permission from the National Academy of Sciences, U.S.

to support plant growth and defense) and reducing primary production at high levels of herbivory (when high plant density and/or stress favor herbivore population growth). As a result, primary production in unmanipulated ecosystems may be maintained near carrying capacity (Chapter 15), thereby maintaining other regulatory services.

## E. Valuation of Ecosystem Services

Traditional value systems have emphasized provisioning services, e.g., food, fiber, wood, fresh water, medicinal and industrial compounds, and cultural and recreational services. Only recently has ecological research demonstrated the value of supporting and regulating services to the sustainability of extractive and cultural services. For example, pollination service is critical to the production of many fruits and vegetables and has recognized monetary value (see section C, above), but adequate pollination depends on complex networks of ecological interactions that maintain a diverse pollinator guild (Bascompte 2009, Forup et al. 2008, R. Gibson et al. 2006, Vamosi et al. 2006, see Chapters 8 and 13) and on nutrient cycling processes that maintain adequate nutrient availability (see Chapters 11–14) for maximum fruit and vegetable development (Bos et al. 2007, Hoehn et al. 2008), values of which are difficult to calculate. Declining pollinator abundance in many areas (Biesmeijer et al. 2006) has prompted efforts to protect or restore native habitats that are necessary to sustain pollinator diversity and abundance (Bascompte 2009, Forup et al. 2008).

Although the variety of medical products provided by bioprospecting (Helson et al. 2009, Kursar et al. 1999), increased crop yields provided by pollinator diversity (Hoehn et al. 2008, A. Klein et al. 2003, Kremen et al. 2007, Winfree et al. 2007) and improved pest management credited to predator and parasitoid diversity (Isaacs et al. 2009, Landis et al. 2000, 2005, Tscharrntke et al. 2005, 2007) demonstrate the potential value of biodiversity conservation, the value of biodiversity *per se* has been difficult to calculate. The diversity of species represents an equivalent diversity of functional attributes and interactions that support ecosystem services (Duffy 2009, Hoehn et al. 2008). The effects of species loss are virtually unknown until such loss threatens essential services (Biesmeijer et al. 2006, Cox-Foster et al. 2007, Genersch 2010). Recognition of the value of ecosystem services has promoted policies in the U.S. and European Union to offset biodiversity loss in agricultural landscapes through agri-environmental programs that subsidize farmers for conservation or restoration practices, e.g., protection or restoration of patches or strips of native grassland, that mitigate the effects of agricultural intensification (Donald and Evans 2006).

Plant growth loss and mortality may remain undesirable in ecosystems which are managed for plant products, but costs of insect outbreaks may be tolerable in public ecosystems managed for multiple uses. For example, the Douglas-fir tussock moth outbreak depicted in Figure 15.10 caused serious losses in timber supply and increased the risk of wildfire in the short term. However, reduced fir density returned forest structure to historic conditions that prevailed prior to fire suppression in Sierran forests and that are the recommended management goal for these forests (North et al. 2007). From this perspective, the outbreak improved the sustainability of ecosystem services from this forest. Furthermore, if expensive salvage harvest can be delayed, compensatory growth over the long term may largely replace lost products (see Chapter 12). To the extent that outbreaks of native insects function in a regulating capacity, suppression may be unnecessary, or even counterproductive, to maintenance of ecosystem services.

## II. INTEGRATED PEST MANAGEMENT

The concept of integrated pest management (IPM) is perhaps the most important application of insect ecology in terms of its contributions to reduced use of pesticides for control of various “pest” species. Most, if not all, species fill important ecological roles in their native ecosystems. However, under suitable conditions, some species can interfere with essential ecosystem services or threaten human health or structures. Insects become viewed as pests when their activities conflict with human needs. It is important to distinguish a species’ role as a pest in a managed ecosystem from its role(s) in natural ecosystems. For example, termites often pose serious threats to the integrity of human cellulose-based building materials, but eliminating termites beyond human-dominated habitats would threaten the integrity of decomposition processes which are required for sustainability of ecosystem productivity (see Chapter 14).

Insects most often become pests as a result of management practices that favor insect population growth. Native insects can become pests when previously scattered native host species, or a related exotic species, become widely planted at high density (e.g., cotton boll weevil, Colorado potato beetle, *Leptinotarsa decemlineata*, see Chapter 4) or when altered disturbance frequency creates an artificially high density of host plants (e.g., western spruce budworm, *Choristoneura accidentalis*, see Chapter 15). Crop species often are bred to reduce bitter (defensive) flavors, facilitating growth and reproduction by herbivorous species (see Chapters 3, 6 and 7).

Humans have transported many species across natural barriers, many intentionally (such as crop, livestock and ornamental species), but many unintentionally (crop-feeding insects and vectors of human pathogens). Some of these species have become serious invasive pests in new habitats, as a result of release from bottom-up and top-down regulatory factors that characterize their native habitat. Their intrusion into natural ecosystems threatens native species through competition, herbivory, predation and parasitism and alters ecosystem structure and function in ways that threaten ecosystem services. More than 11,000 alien species in Europe cost at least US\$13 billion annually in lost ecosystem services, but because environmental and economic impacts are known for only about 10% of these invasive species, their actual cost is likely to be much higher (P. Hulme et al. 2009). Efforts to control such species are expensive and not always effective.

Recent advances in understanding the complex effects of insects and their interactions with other organisms on ecosystem services have influenced evaluation of the need for insect management. Management goals for natural ecosystems, especially forests and grasslands, have become more complex in many regions, as societal needs have changed from a focus on extractive uses, e.g., fiber, timber, or livestock production, to include protection of water yield and quality, fisheries, recreational values, biodiversity and ecosystem integrity. In many cases, the net effects of native species on ecosystem services are neutral or positive, and/or the cost of control is not warranted by marginal benefits (see Ecosystem Services, above). Development of the Integrated Pest Management and Integrated Forest Protection (IFP) concepts has been a major application of insect ecology to management of ecosystem services.

### A. Development of the IPM Concept

Before synthetic chemical insecticides became available in the 20<sup>th</sup> century, entomologists combined their knowledge of population biology, plant resistance and biological control agents into multitactic control strategies (e.g., T. Harris 1841, Kogan 1998, R. Painter 1936, 1951, C. Riley 1883, 1885, 1893, C. Smith 2005). One of the earliest insecticides was pyrethrum, prepared from the powdered flower heads of *Pyrethrum roseum*,

which was used at least as early as 1800 to control insects in Asian countries south of the Caucasus Mountains (C. Riley 1885). However, pyrethrum was effective only in direct contact with the insect and became ineffective within an hour of application. As a result, pest management in the late 1800s and first half of the 20th century became dominated by broad-spectrum toxins that persisted longer.

Forbush and Fernald (1896) noted high tolerance of gypsy moth larvae to arsenical compounds (high survival at tissue concentrations 12 times the lethal dose for humans), and Melander (1923) reported that San Jose scale, *Quadraspidiotus perniciosus*, in Washington was becoming progressively more tolerant of insecticides, particularly sulfur compounds. These examples represent the earliest documentation of insecticide resistance. Non-target effects threaten ecosystem function and stability (D. Baldwin et al. 2009, Claudianos et al. 2006, S. Smith et al. 1983). Although insecticide development during the past 50 years has emphasized shorter residual times and reduced non-target effects, continued problems with pesticide resistance have led to increased attention to alternative strategies (Hsu et al. 2006, 2008, Ottea and Leonard 2006). The IPM concept developed fully during the 1960s when various tactics were combined with consideration of economic thresholds and multiple pests and non-pests (Kogan 1998, Nicholls and Altieri 2007, Stern et al. 1959, van den Bosch and Stern 1962).

The last legal use of DDT in the U.S., in 1974 against a Douglas-fir tussock moth outbreak in Oregon and Washington, reflected growing public concern about pesticide use and demonstrated the value of alternative control methods. Because the U.S. Environmental Protection Agency (EPA) had cancelled use of DDT in the U.S. in 1972, its use in 1974 required emergency authorization, based on an apparent lack of practical alternatives. As part of this authorization, the EPA mandated that research on alternative methods of control be intensified and that experimental plots be established to demonstrate the efficacy of DDT (Brookes et al. 1978). In the mandated experiment, tussock moth populations declined in all plots, regardless of DDT treatment, leading to discovery that nuclear polyhedrosis virus (NPV), *Baculovirus* spp., naturally ends tussock moth outbreaks in 3–4 yrs. NPV had been recognized as a natural mortality agent, but its importance had been masked by prior control programs that prevented development of epizootics. Aerial application of technical grade NPV became the preferred means of control for incipient outbreaks.

The current concept of IPM represents an intersection between pest management and insect ecology that emphasizes integration of natural ecological processes with various management methods, and addresses interactions among the diversity of target and non-target species, to maintain pest population sizes below levels that would interfere with maintenance of ecosystem services (cf. Kogan and Jepson 2007). Control methods for any particular species must be consistent with the complex of other insects and pathogens to avoid outbreaks of non-target species. The following four IPM principles were designed to guide pest management decision-making.

First, pest management strategies should be consistent with resource management goals. Killing insects does not necessarily improve crop yield, and insecticides can disrupt other ecosystem services, especially pollination (Claudianos et al. 2006) and fisheries (S. Smith et al. 1983). Furthermore, to the extent that native insects represent regulatory mechanisms in natural ecosystems (Chapter 15), insect control may be unnecessary and even counter-productive to long-term maintenance of ecosystem services.

Second, the goal of pest management is not to control a pest population, but rather to maintain population size below a threshold (“injury level”) that would cause losses

to ecosystem services that would exceed the costs of control. Implementation of control measures should be based on predictive models that indicate when an insect population is expected to exceed the injury level (Rabb et al. 1984). Such prediction assists in establishing an action threshold at which planned action should be initiated to prevent the population from exceeding the injury level. In many cases, this threshold is based on economic losses in production of agricultural or forest commodities. However, thresholds also can be established to prevent other undesirable effects on ecosystem services, such as change in vegetation composition or structure in nature preserves.

Third, management strategies must be consistent with ecological principles. Understanding the environmental factors that promote a species to pest status and augmenting bottom-up and top-down factors to disrupt pest population growth should accomplish resource production goals while minimizing unintended consequences for food web interactions and ecosystem services.

Finally, when pest control is necessary, using multiple remedial tactics, including cultural practices, pheromone disruption, biological control, and limited insecticide application, can effectively reduce pest population levels and prevent or delay genetic adaptation to a particular tactic (e.g., Barbosa 1998, Huffaker and Messenger 1976, Kogan 1998, Lowrance et al. 1984, Rabb et al. 1984, Reay-Jones et al. 2003, Rickson and Rickson 1998, R.H. Smith 2007). In the boll weevil example described above, successful control ultimately depended on a combination of crop diversification, mating pheromones and destruction of overwintering habitat, as well as limited use of insecticides on local populations.

In practice, IPM requires a stepwise decision-making process, beginning with definition of management goals or desired future conditions. Defined goals determine which available management options are most appropriate in a given situation. Second, adequate estimates of population size (see Chapter 5) and the predicted time to reach the action threshold establish the timeframe for initiating necessary action (Schowalter et al. 1982). Third, evaluation and comparison of available management options (including no action) on the basis of expected accomplishment of management goals, effectiveness within the established timeframe, cost, environmental and social consequences, etc. permits ranking of options in terms of their net benefits relative to costs (Gatto et al. 2009). In many cases, insect control may not be the best option, e.g., if compensatory growth prior to resource harvest would replace lost production. Computerized decision-support models have been developed to aid the evaluation of management options. Such models integrate a user interface with submodels that predict population growth, effects of management actions and calculated benefit/cost to provide benefit/cost analysis under various user-defined scenarios (e.g., C. Shaw and Eav 1993). Finally, monitoring of management activity and evaluation of the benefits and costs of the completed project are essential to improved future (adaptive) management. Tactics available for managing crop and forest pests, disease vectors, and urban pests are described below.

## B. Ecological Tactics for Managing Crop and Forest “Pests”

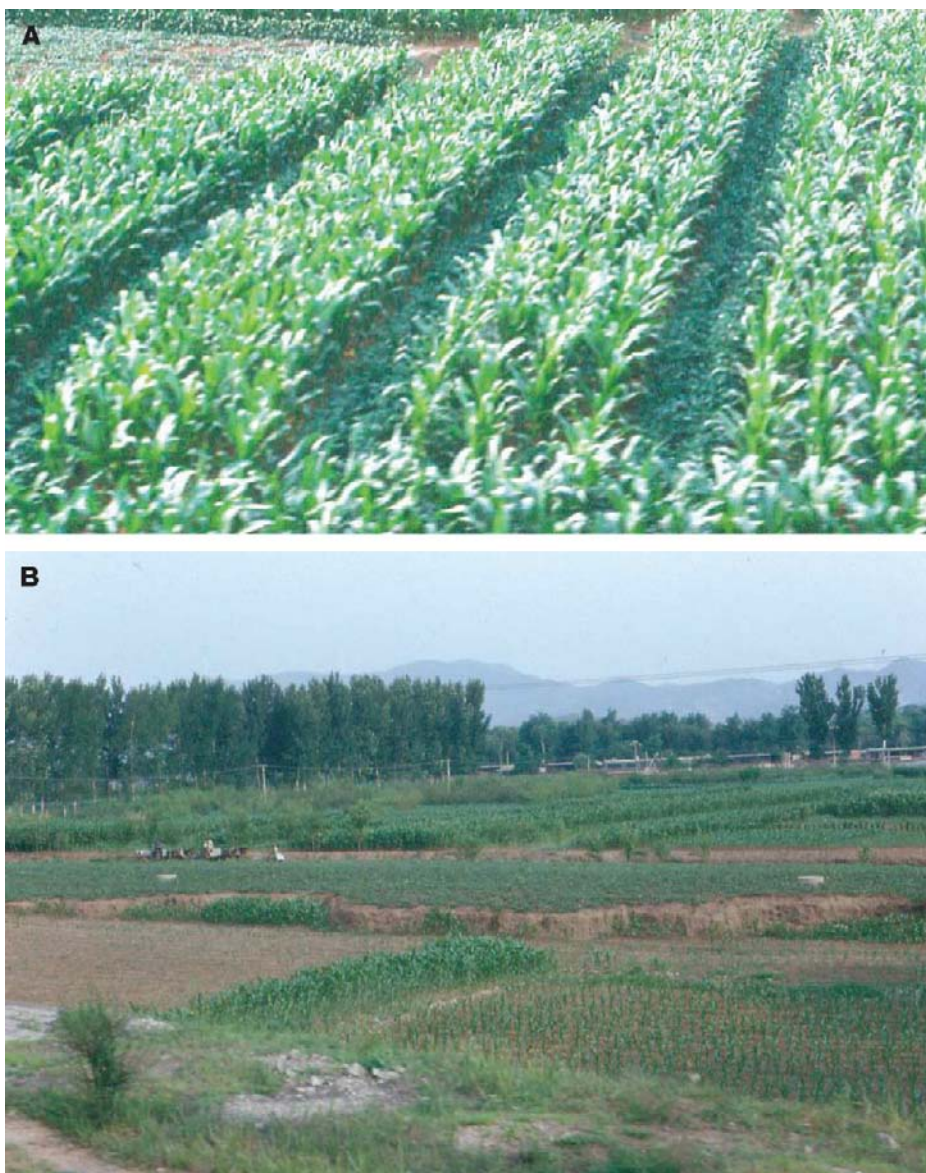
Management of crop and forest “pests” has been a major application of insect ecology for the past two centuries (e.g., Riley 1878, 1883, 1893, Kogan and Jepson 2007). Forests present special challenges for pest management. Access to tall canopies for assessment of injury levels is limited. Aerial surveys can provide data on severity and extent of injury, but

ground checking is necessary to confirm the identity of the pest. Furthermore, forests are subject to the cumulative effects of insects and pathogens, as well as other factors, that predispose forests to other factors for long periods before injury becomes apparent. This requires a degree of attention to changes in forest conditions that often is not supported within operating budgets. Forests in many regions are managed for multiple uses that may be affected by insects in complementary ways. Finally, controlling insects in forests often is not cost-effective, given marginal profits and losses due to pest control or unscheduled salvage harvests.

Cultural methods for preventing resource losses were the subject of investigation as early as the late 1700s (C. Smith 2005, R. Painter 1951) and remain the most sustainable option for minimizing crop damage by both insects and pathogens. In managed forests, the promotion of site-adapted tree species and adequate tree spacing generally are sufficient to minimize losses to insects or pathogens (e.g., Nealis et al. 2009). In agricultural crops, planting resistant cultivars, mixing different crops (Fig. 16.5), including agro-forestry, and crop rotation among host and non-host species have a long history of use (e.g., Barbosa et al. 2009, Gliessman 2007, Nicholls and Altieri 2007, S. Risch 1980, 1981), but inexpensive insecticides often are favored over these more sustainable options. Reay-Jones et al. (2003) estimated that planting resistant varieties of sugarcane could reduce crop losses to the Mexican rice borer, *Eoreuma loftini*, by 24%, and irrigation with 30 cm of water would reduce losses by 29%, substantially reducing the need for pest control. Mixing of different crops can reduce pest populations and crop losses substantially (S. Risch 1980, 1981, H. Zhou et al. 2009). Even mixing resistant and susceptible varieties of the same crop in the same field can provide significant benefit for pest management (Garrett and Mundt 1999).

Newer cultural practices emphasize the protection of soil moisture, fertility and nutrient cycling processes that minimize crop stress and retain a diversity of predators and parasites to control herbivore populations (Altieri 2002, Denys and Tschardtke 2002, Gliessman 2007, Isaacs et al. 2009, Landis et al. 2000, 2005, Nicholls and Altieri 2007, Pretty et al. 2003, Thies et al. 2003, Tschardtke et al. 2005, 2007, Vincent et al. 2003, H. Zhou et al. 2009). Examples include non-tillage, intercropping or cover crops of N-fixing legumes, mulch application and conservation of non-crop patches and hedgerows within the agricultural landscape. Another recent addition, trap cropping, involves planting a border strip of an attractive host variety around the crop field to concentrate pests in a small area, either to keep them out of the crop or to focus control measures more efficiently (Hokkanen 1991, Kogan and Turnipseed 1987). Pretty et al. (2003) surveyed 208 farming projects (representing 9 million farms covering 29 million ha in 52 developing countries in Africa, Asia and Latin America) in which farmers have adopted environmentally-sensitive practices and technologies. Of 89 farming projects with reliable data, 93% showed an increase in food production per hectare, resulting from increased water use efficiency, improved soil health and fertility, and minimal or zero pesticide use. Shifts to more sustainable agricultural practices have substantial benefits for the rural poor in developing countries.

A number of remedial options are available when the suppression of pest populations becomes necessary. Modern insecticides, including a variety of insect growth regulators (IGRs, such as methoprene) and chitin synthesis inhibitors (CSIs, such as noviflumuron), remain an option when rapid reduction in pest populations becomes necessary. Their use can be minimized by restricting application to trap crop borders around crop fields (e.g., Buteler et al. 2009) and by employing a variety of ecologically-based alternatives.



**FIG. 16.5** Examples of multi-cropping to hinder spread of insect species over an agricultural landscape in northeastern China. A) embedded intercropping among rows; B) multiple crop species arranged in strips.

Use of the options described below still requires consideration of insect adaptation and potential consequences for environmental conditions.

Physical control methods involve use of manual or mechanical tools or barriers for killing insect pests (C. Riley 1878, 1883, Vincent et al. 2003). Hand-picking insects from crop plants has been a basic control tool for centuries (C. Riley 1883, 1885). Collected insects can be killed or used commercially (Cerritos and Cano-Santana 2008, Ramos-Elorduy



2009). Trenches or other barriers have a long history of interrupting movement of walking insects, especially marching locust nymphs (C. Riley 1878, 1883). Horse-drawn hopperdozers were used in the early 1900s to scrape grasshoppers into oil- or kerosene-filled trenches (C.R. Jones 1917, R.C. Smith 1954). Sexton and Schowalter (1991) described the cost and effectiveness of several tree bole barriers to prevent a flightless cone-feeding weevil, *Lepesoma lecontei*, from climbing into seed orchard trees. Prescribed fire also may be used to control the populations of ground-based insects (C. Riley 1880, K. Miller and Wagner 1984). Other physical control methods include cold water sprays in agricultural fields to disrupt phenological synchrony between insects and plants, and hot water baths, to kill insects in post-harvest produce (Vincent et al. 2003).

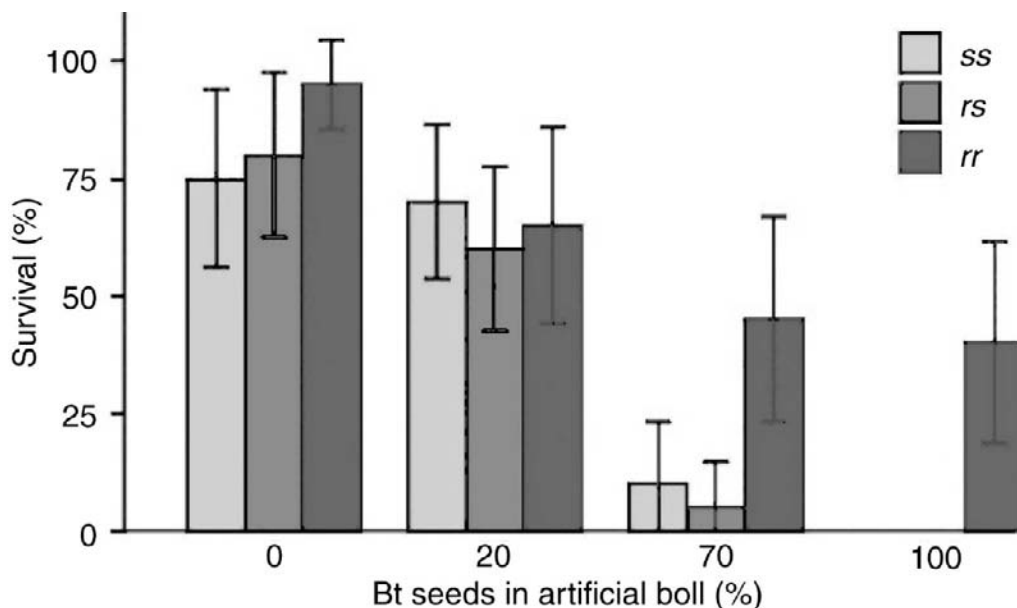
Many viral (e.g., nuclear polyhedrosis virus, NPV), bacterial (e.g., *Bacillus thuringiensis*, Bt), and fungal (e.g., *Beauveria*) pathogens can be applied in the same manner as chemical controls and often are confused with chemical insecticides. The advantage of microbial control agents is their ability to replicate within their hosts and spread epizootically through the target population (see below).

The effectiveness of many microbial pathogens has led to genetic modification of some crops to express toxic bacterial proteins, such as Bt endotoxins Cry1A, Cry1Ac and Cry2Ab. Although controversial in many countries, transgenic corn, wheat, cotton and other crops have reduced the use of more toxic insecticides substantially (Carrière et al. 2003, Cattaneo et al. 2006) and show fewer effects on non-target species than do insecticides (Marvier et al. 2007). Nevertheless, pollen and plant detritus containing Bt toxins may affect soil organisms and decomposition, and they may be exported to other ecosystems, such as streams, where they could affect non-target organisms (Hansen Jesse and Obrycki 2000, Losey et al. 1999, O'Callaghan et al. 2005, Rosi-Marshall et al. 2007, Sears et al. 2001, Zangerl et al. 2001).

Widespread planting of transgenic crops in some regions threatens to undermine their long-term effectiveness, given the ability of insects to adapt quickly to any strong selection factor (F. Gould 1998, Kruger et al. 2008, Tabashnik et al. 2008). Therefore, a high-dose-with-refuge strategy is recommended to prevent survival of pests on the Bt crop and to maintain a large, non-adapted population in non-Bt refuges (Alstad and Andow 1995, Carrière et al. 2003, Ives and Andow 2002, Kruger et al. 2008, Tabashnik et al. 2008).

Incipient resistance in some target species (Huang et al. 2007, Ottea and Leonard 2006) has led to insertion of multiple Bt toxin genes into some crop plants to delay insect adaptation, to the extent that cross-resistance to the different genes is minimized. Nevertheless, long-term effectiveness could be undermined if either or both Bt toxins are not produced at concentrations sufficient to kill all herbivores (Kranthi et al. 2005, Mahon and Olsen 2009, Showalter et al. 2009), or if pollen contamination of non-transgenic refuges or native vegetation leads to variable Bt concentrations across the landscape (Fig. 16.6, Chilcutt and Tabashnik 2004, Heuberger et al. 2008a, b, D. Llewellyn et al. 2007, Romeis et al. 2008, Zangerl et al. 2001). This requires attention to soil moisture, nutrient availability, or other conditions that stress crop plants and influence production of Bt toxins, and to the landscape structure of Bt and non-Bt crops (especially for insects with broad host ranges that might include multiple transgenic crops), as well as cooperation among scientists, growers, and government agencies (Carrière et al. 2001a).

Other genetic tools to control pest populations are being explored, but these also may have unintended consequences for communities and ecosystems. RNA interference (RNAi) is a transgenic method that can inhibit target insect expression of P-450 genes for



**FIG. 16.6** Percentage survival and 95% confidence intervals for pink bollworm larvae of susceptible (*ss*), resistant (*rr*) and heterozygous (*rs*) genotypes on artificial cotton bolls containing 0–100% Bt seeds. From Heuberger et al. (2008a) with permission from the Entomological Society of America.

detoxification of plant defenses. RNAi is accomplished by incorporating double-stranded RNA (dsRNA) specific to the detoxification gene. Y. Mao et al. (2007) demonstrated that adding dsRNA to the diet of cotton bollworm, *Helicoverpa amigera*, decreased the expression of CYP6AE14, the bollworm's primary detoxification gene, in the midgut and reduced larval growth. This technology could permit focused control of a specific target species in specific situations with minimal non-target effects (Burt 2003).

Homing endonuclease technology (Burt 2003) involves engineering a homing endonuclease gene (HEG) that encodes for an enzyme that recognizes and cleaves a specific 20–30 bp sequence on chromosomes that do not contain the HEG. The intact HEG + homologue is used by the cell's repair system as the template, so after repair both chromosomes contain the HEG. The gene would spread quickly through the population from a relatively small number of introduced individuals, providing for rapid manipulation of population characteristics. For example, mosquitoes could be engineered to make them ineffective as disease vectors. Although such options seem attractive because of their apparent focus on the target species, they fail to address potential effects of the engineered population on the network of direct and indirect interactions in ecosystems, e.g., the variety of vertebrates that interact with mosquitoes.

A promising new tool is application of chemical elicitors, such as jasmonic acid (see Chapters 3 and 8), to induce production of natural defenses by crop plants in advance of herbivory (e.g., Senthil-Nathan et al. 2009, M. Stout et al. 2002, Thaler 1999b, Thaler et al. 2001). This approach would be most effective when infestations can be anticipated reliably, and action thresholds are high, because of delay in expression of induced defenses. However, expression of natural or transgenic defenses by plants depends on adequate resources for growth and defense (see Chapter 3).

Biological control was practiced in China as early as the third century A.D., e.g., ants were sold for the control of citrus insect pests (Konishi and Itô 1973). C.V. Riley initiated the practice of importing natural enemies from a pest's region of origin for control purposes (C. Riley 1893). He was responsible for the first widely successful biological control program, the importation of the coccinellid, *Rodolia (Vedalia) cardinalis*, to control the cottony cushion scale, *Icerya purchasi*, that was devastating California's citrus crops (Hagen and Franz 1973). As a result, Riley is often called the "Father of Biological Control".

This success launched an increasing number of introductions of parasitic or predaceous organisms from a pest's region of origin for biological control purposes (Van Driesche and Bellows 1996). In some cases, herbivorous insects have been introduced to control invasive plant species (R. Doyle et al. 2002, Louda et al. 2003), but biological control agents often have targeted insect pests (Louda et al. 2003). Introducing biological control agents from the pest's region of origin requires consideration of the agent's ability to become established in the new community and its effects on non-target species (Delfosse 2005, Louda et al. 2003, McCoy and Frank 2010, Symondson et al. 2002, van Lenteren et al. 2006). Early failures in biological control often were due to inaccurate identification of the most effective predator or parasite species. For example, sibling species may not be equally effective in regulating a host population; superparasites or cleptoparasites reduce the effectiveness of the primary biocontrol agent; or endemic predators may interfere with the efficacy of introduced parasitoids (Erbilgin et al. 2004). Furthermore, ecosystem integrity can be disrupted by introduction of non-specific biocontrol agents that attack native, as well as invasive, hosts (Louda et al. 2003). Refinement of quarantine and testing procedures for potential biocontrol agents and selection for more specialized agents have minimized these problems, but it is difficult to anticipate all the consequences of an introduction (Delfosse 2005, Hokkanen et al. 2007, Louda et al. 2003, McCoy and Frank 2010).

An alternative to the introduction of biological control agents is the conservation of native predator, parasitoid and parasite diversity within agricultural landscapes (Isaacs et al. 2009, Landis et al. 2000, 2005, Tscharrntke et al. 2005, 2007). This requires attention to non-crop features that are necessary to sustain populations of these regulatory agents over areas greater than the crop patches. In particular, conservation of hedgerows and patches of natural ecosystems maintains populations of alternate hosts and floral resources that are necessary to sustain predators and parasitoids during periods when their hosts on crop plants may be absent (Hassall et al. 1992, Landis et al. 2000, Marino and Landis 1996, Thies and Tscharrntke 1999). Such practices require cooperation among multiple landowners on a landscape scale. Native predators and parasites often do not recognize invasive species as potential prey or hosts (e.g., Adams et al. 2009).

Pheromones have become highly valued tools for pest management, because of their specificity in attracting target species (Groot et al. 2006, Hemmann et al. 2008). Identification of the particular blend of volatile compounds that are used by a species (see Chapter 4) is necessary for best effect (Tumlinson et al. 1969). Pheromones can be used in a number of ways for management purposes. Pheromone-baited traps can be placed in strategic locations to detect and monitor the distribution and abundance of a target species, such as a potential invasive species (e.g., Boddum et al. 2009, Gries et al. 2009). Pheromones in controlled-release containers placed in the field or infused in light, plastic filaments applied aerially can be used to disrupt the normal attraction

of mates (C. Alfaro et al. 2009, Niwa et al. 1988, Vacas et al. 2009) or to repel insects from the treated site (Gillette et al. 2009). Baited traps also can be used to reduce target populations locally (D. Bray et al. 2009, Vargas et al. 2009). These applications will be most effective in the control of small or relatively isolated populations, for which saturation of the populated area with pheromone is feasible, and attraction of additional target insects from outside the patch is limited, e.g., orchards and islands (Yamanaka and Liebhold 2009).

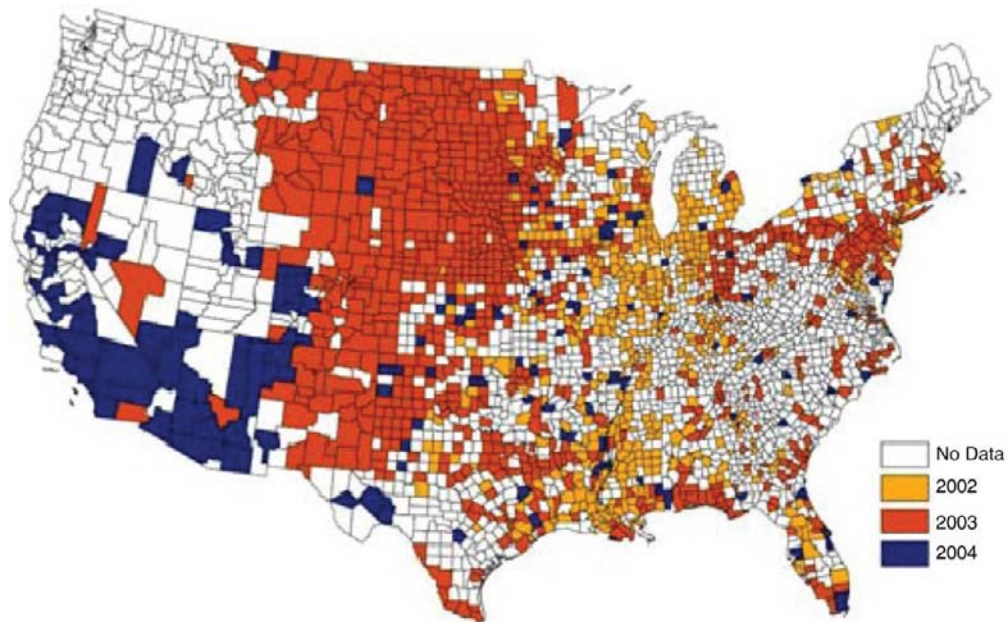
Sterile insect release (SIR) is an option in some circumstances (J. Myers et al. 1998, Yamanaka and Liebhold 2009). This technique requires mass rearing, sterilization and inundative release of sterile insects to saturate the target population with non-reproductive individuals. A critical requirement for success is a single-mating population. If females can mate more than once, unsuccessful mating with a sterile mate does not necessarily prevent reproduction. Eradication of the screwworm fly, *Cochliomyia hominivorax*, from the U.S. during the 1960s, and subsequently from Mexico by 1990, remains a classic example of the successful use of this technique, but required the release of millions of sterile males at a total cost of US\$750 million (J. Myers et al. 1998, Yamanaka and Liebhold 2009). Other sterile insect release programs have been most successful on islands (J. Koyama et al. 2004, Yamanaka and Liebhold 2009).

Advances in remote sensing and geographic information systems (GIS) have improved the precision of pest management activities (Bongiovanni and Lowenberg-Deboer 2004). Within-field patterns of pest density can be superimposed on crop production gradients to identify areas of greatest potential increase in yield under different pest management scenarios (Willers et al. 2005). In place of traditional broadcast methods, pest management can be focused at locations where it will be most economically or ecologically beneficial. Furthermore, fertilizer and pesticide application rates can be tailored to habitat conditions to avoid over-application and minimize the contamination of groundwater or streams (Bongiovanni and Lowenberg-Deboer 2004).

### C. Ecological Tactics for Managing Medical and Veterinary “Pests”

Insects and insect-vectored diseases have serious effects on human and livestock health (B. Allan et al. 2009, R. Bray 1996, Lockwood 2008, Merritt et al. 2005, Perlman et al. 1976, R. Peterson 2009, Vittor et al. 2006, see Chapter 8). Many human diseases, particularly malaria, typhus, yellow fever, bubonic plague, and equine encephalitis, are vectored by arthropods among humans and other animal species. Rodents are reservoirs for several important human diseases, but livestock, wildlife and birds also are sources of inoculum (Diamond 1999). The rapid spread of West Nile Virus across North America between 1999 and 2004 reflected a combination of transmission among multiple hosts by multiple mosquito species and rapid spread across the continent by infected birds (Fig. 16.7, B. Allan et al. 2009, Marra et al. 2004, Turell et al. 2005, see Chapter 8).

Disease prevention or control must address interactions among disease reservoirs, insect vectors and other organisms. Mosquito control, for example, would benefit the hosts of vectored diseases, but would negatively affect food web interactions that might be critical to sustainability of ecosystem services. While other insect species might replace mosquitoes in some of their functions, differences in phenology or other life history attributes might make them less available or less desirable resources. C.G. Jones et al. (1998) reported that human risk of contracting lyme disease in oak forests reflected complex interactions among tick vectors, deer and rodent reservoirs that feed on acorns, gypsy



**FIG. 16.7** Spread of West Nile virus across the U.S. 2002–2004 based on peak human incidence by county. From B. Allan et al. (2009) with permission from the authors and Springer Science+Business Media.

moth outbreaks that affect acorn availability, and rodent predation on gypsy moth pupae. Manipulation of acorn abundance demonstrated that gypsy moth abundance increased at low acorn abundances, due to reduced rodent abundance and predation, and incidence of Lyme disease increased at high acorn abundances, due to increased reservoir density. Furthermore, B. Allan et al. (2009) found that bird diversity was inversely related to the competence of the West Nile Virus reservoir, indicating that less diverse bird assemblages tended to be dominated by more competent reservoirs and suggesting that protection of bird diversity could reduce human incidence of this disease.

The importance of arthropod-vector-borne diseases to human population dynamics, including the success of military campaigns (R. Bray 1996, Lockwood 2008, R. Peterson 1995, 2009), underscores the importance of understanding human roles in ecological interactions. Increasing human intrusion into previously unoccupied ecosystems has exposed humans to novel animal diseases that may involve insect vectors (R. Peterson 2009, Vittor et al. 2006, see Chapter 2). Human transport of disease agents, their vectors and/or livestock reservoirs has increased the globalization of many diseases; pathogens that require other reservoir species for a portion of their life cycle tend to remain more restricted in distribution (K. Smith et al. 2007). Ecosystem disturbance promotes population growth of at least some disease vectors (Merritt et al. 2005, Vittor et al. 2006). Transmission frequency increases with the density and movement of human, reservoir and/or vector populations. Management must involve a combination of approaches that augment natural controls (e.g., protect insectivorous fish, amphibians, birds and mammals, as well as invertebrate predators) and reduce exotic breeding habitat for vectors (e.g., water collected in discarded tires, flower pots, or roadside ditches) and/or reservoir hosts, as well as prevent inoculation of humans who may be exposed.

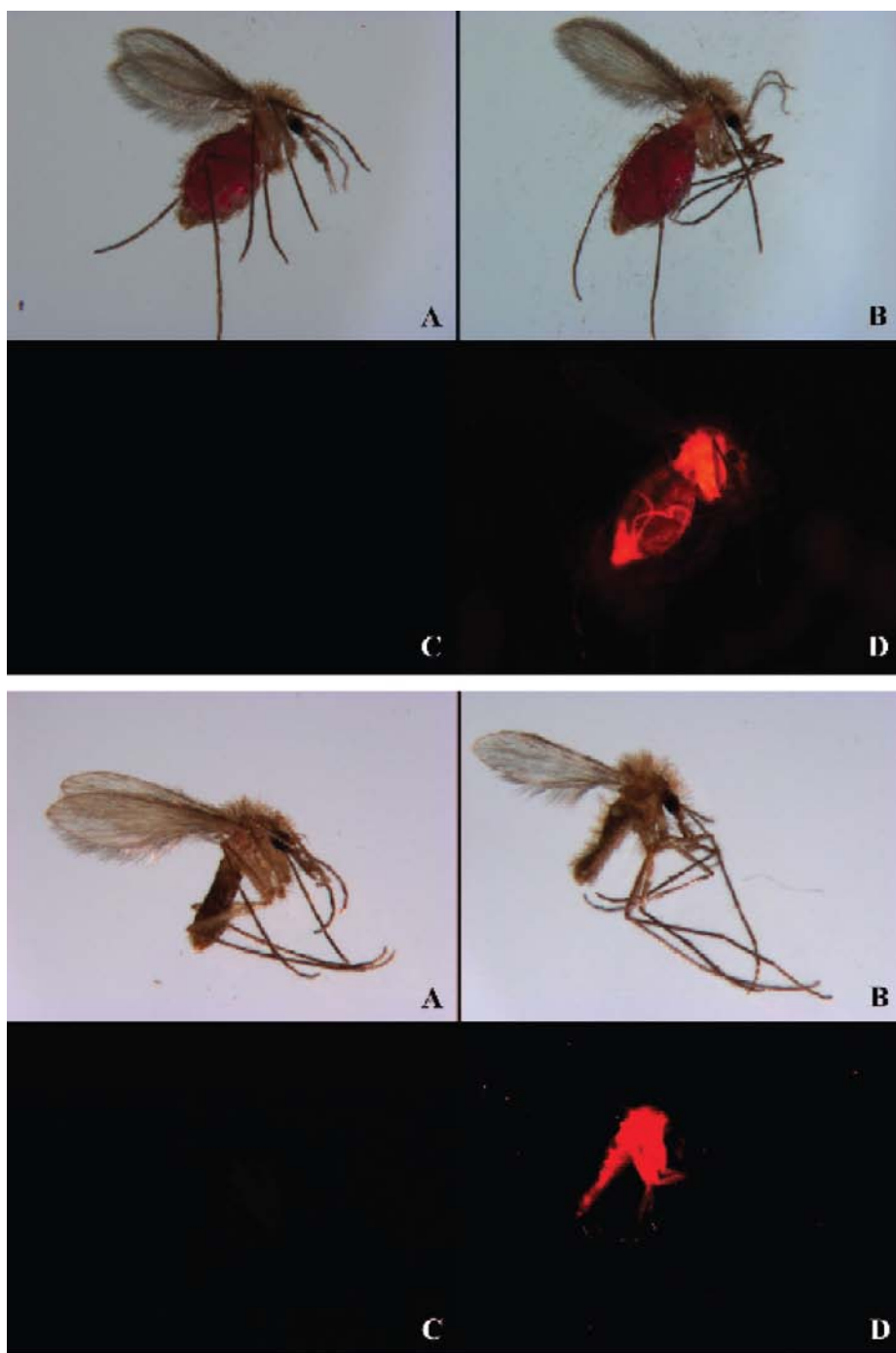
Control of mosquitoes and other vectors has been accomplished largely by broad-scale application of insecticides, including (historically) DDT and (currently) pyrethroids. Insect vectors are capable of adapting quickly to insecticides (e.g., Ranson et al. 2002). Furthermore, application of insecticides over bodies of water, where mosquito breeding is concentrated, can be counterproductive, especially for aquaculture yields. Application of *Bacillus thuringiensis* var. *israelensis* (Bti) and *Bacillus sphaericus* to aquatic habitats has controlled mosquito larvae effectively under some conditions, but the bacterial protein must be ingested and is only active for 2–3 days (Russell and Kay 2008, Skovmand et al. 2009). Mosquitoes also can become resistant to these bacteria (Singh and Prakash 2009). Several entomopathogenic fungi, including *Beauveria bassiana* and *Metarhizium anisopliae*, show promise for adult vector control (Scholte et al. 2005). Unlike bacteria or viruses, fungal entomopathogens can infect and kill insects through contact, without being ingested.

Various chemicals, including sulphur, permethrin and N,N-diethyl-meta-toluamide (DEET), have been used to repel vectors from individuals or kill vectors only on contact with treated hosts. However, these repellents can have negative effects on human health and environmental conditions. Variation in attractiveness to vectors among individual humans provides additional opportunities for protection. J.G. Logan et al. (2009) identified a number of human-emitted compounds that differed in aerosol concentration between subjects who were attractive or non-attractive to biting midges, *Culicoides impunctatus*. Two of these compounds, 6-methyl-5-hepten-2-one and geranylacetone, significantly reduced the attraction of midges to baited traps in the field. D. Bray et al. (2009) reported positive results for attraction of a leishmaniasis vector, *Lutzomyia longipalpus*, to pheromone traps in the field. Future use of such repellents and attractants in human-dominated sites may avoid potential problems for human health or environmental conditions.

A new “feed-through” technique targets insect vectors only during the portion of their life cycle when they depend on non-human hosts (Mascari and Foil 2010, Mascari et al. 2007a, b). For example, phlebotomine sand flies vector trypanosomes, the causal agent of leishmaniasis, between rodent and human hosts. Adult sand flies are hematophagous and transmit the disease while feeding on host blood. Sand fly larvae typically live in rodent burrows and feed on rodent feces, making them difficult targets for control. Broadcast application of rodenticides negatively affects predator populations and ecosystem integrity. The feed-through technique involves provision of rodent food which is infused with an insecticide that is non-toxic to rodents. Several insect growth regulators and chitin synthesis inhibitors can pass through the rodent digestive system and remain sufficiently toxic to kill coprophagous fly larvae (Mascari and Foil 2010, Mascari et al. 2007a, b). Sufficient insecticide is assimilated by the rodent to kill adult flies during bloodfeeding (Mascari et al. 2007a, b). Incorporating markers into the bait permits tracking of flies that feed on it (Fig. 16.8, Mascari and Foil 2009). The advantage of this technique is that, because sand flies have relatively short dispersal distances, baiting rodents within buffer zones around human habitations could provide adequate control of vectors with minimal non-target effect (Mascari and Foil 2009).

#### D. Ecological Tactics for Managing Urban “Pests”

Urban environments create conditions that are unique in the landscape (Arnfield 2003, Frankie and Ehler 1978, Raupp et al. 2010). Temperature, precipitation, air turbulence and drainage conditions are altered. Urban temperature can be as much as 10°C higher



**FIG. 16.8** Top set) Female sandfly A) and C) took bloodmeal from hamster fed control diet; female B) and D) took bloodmeal from hamster fed diet containing rhodamine-B dye. Bottom set) Female sandfly A) and C) fed as larva on hamster fed control diet; female B) and D) fed as larva on hamster fed on diet containing rhodamine-B dye. From Mascari and Foil (2009) with permission from the Entomological Society of America.

than surrounding suburban and natural areas, creating an urban “heat island”, characterized by strong air turbulence and vertical shear (Arnfield 2003). Convective processes alter precipitation patterns in, and downwind from, urban centers (Changnon et al. 1991). Tall buildings along a grid of roadways create an extreme 3-dimensional structure. A variety of chemical aerosols from combustion and other human activities alters the urban atmospheric composition.

The urban community is dominated by lawns, exotic ornamental and weedy species, pets and humans. Human structures provide ideal habitats for many insect species, including ants, termites, cockroaches and flies. Stable temperature and moisture, unsealed food, human or animal wastes, and “detrital” resources (e.g., structural wood) provide attractive resources. Empty containers, tires, flower pots and other debris collect water and provide habitat for mosquitoes amid numerous vertebrate hosts.

Termites, carpenter ants and wood-boring beetles often threaten wooden structures through their excavation of structural wood. Considerable investment has been made in research to reduce such damage, particularly in historically important structures. Optimal management of these insects requires multiple approaches, including chemical barriers to make buildings less attractive; removal or treatment of infested building material, nearby wood waste, or infested trees; pheromone disruption of foraging behavior; non-repellent termiticides that can be transferred in lethal doses to other colony members through trophallaxis, and microbial toxins to inhibit gut flora and fauna (J.K. Grace and Su 2001, Husseneder et al. 2003).

Other urban “pests” include nuisances and health hazards, such as cockroaches, bed bugs, exotic ants, biting or swarming flies, and even winter aggregations of ladybird beetles, which may be promoted by unsanitary conditions or the proximity of lawns, gardens, and ornamental pools. Fumigation or heating of reused furniture before bringing it inside human habitations will minimize introduction of some pests, but many species are highly resistant to most household insecticides because of frequent exposure. Relatively simple approaches such as sanitation, avoidance of transporting insects from infested to uninfested areas, and sealing of cracks and crevices can prevent entry or survival of many species, such as cockroaches and bedbugs. Pheromones may be useful in controlling some household pests (Liang et al. 1998).

The complexity of urban structures, including shared walls, rooftop or balcony gardens, and multiple sources of moisture and access by small insects, makes treatment and monitoring difficult. Treatment of large areas is necessary to reduce overall population sizes and dispersal into treated areas. In some cases, government-subsidized programs have been established to supplement individual property-owner efforts to control structural pests, such as the invasive Formosan subterranean termite, *Coptotermes formosanus* (Guillot et al. 2010).

Urban vegetation that is stressed by elevated temperatures, pollutants, fertilizer application, soil compaction, impervious surfaces and altered drainage conditions is vulnerable to herbivorous insects (Cregg and Dix 2001, Frankie and Ehler 1978, Raupp et al. 2010). Although herbivorous insects can be managed through a combination of tactics (see II. B above), urban dwellers typically rely on chemical insecticides, thereby contributing to the development of resistance among target species. Frequent pesticide application also reduces the abundance of desirable insects, such as butterflies, dragonflies and biological control agents. Educating city-dwellers about the ecological factors that promote or suppress these insects in urban settings will improve management strategies.



### III. CONSERVATION/RESTORATION ECOLOGY

Relatively few studies have addressed insects as part of ecosystem conservation or restoration projects (Boecklen 1991, Samways 1995, Samways et al. 1996). Some colorful insects, such as the Fender's blue butterfly, *Icaricia icarioides fenderi*, and American burying beetle, *Necrophorus americanus*, have become targets for conservation or restoration efforts (M. Wilson et al. 1997). However, some insects selectively reduce the abundance and biomass of host plants (e.g., Louda et al. 2003, McEvoy et al. 1991, 1993, see chapter 12), whereas others may be critical to plant reproduction (e.g., Schütz et al. 2008, Steffan-Dewenter et al. 2002, see Chapter 13), and may affect the success of conservation or restoration projects which are focused on plant species or integrated communities (Molano-Flores 2009). Therefore, the roles of insects as herbivores, pollinators, seed dispersers or prey should be considered as part of conservation/restoration planning. Furthermore, the restoration of species or ecosystems requires a consideration of the mechanisms and processes that maintain key interactions which are necessary for survival of target taxa or communities (Lake et al. 2007).

Loss of key insect species or functional groups would deprive dependent species of food or other resources, and lead to ecosystem degradation (Nichols et al. 2009, Tylianakis et al. 2008). Many vertebrates of conservation concern feed primarily or exclusively on insects (see Chapter 8). Stewart and Woolbright (1996) calculated that adult tree frogs, *Eleutherodactylus coqui*, at densities of about 3300 ha<sup>-1</sup>, consumed 10,000 insects ha<sup>-1</sup> per night in Puerto Rican rain forest; 17,000 pre-adult frogs ha<sup>-1</sup> ate an additional 100,000 insects ha<sup>-1</sup> per night. During dry periods when the availability of insect prey declined, many frogs were emaciated and had empty guts, suggesting the vulnerability of these insectivores to reduced abundance of insects. Similarly, restoration of aquatic systems for protection of fisheries requires attention to the composition and abundance of both aquatic insects (Lake et al. 2007) and riparian insect inputs (Baxter et al. 2005, Wipfli 1997, Wipfli and Musslewhite 2004) which may be equally important sources of prey for fish.

Fragmentation and/or conversion of natural ecosystems remains the most serious threat to conservation and restoration efforts, both regionally and globally. Fragmentation reduces and isolates populations of sensitive species, as described in Chapter 7, and increases the availability of degraded habitat and other resources for early successional, highly vagile species that are most likely to become pests or public health concerns (Póvoa et al. 2003, Vittor et al. 2006). Conversion of streamside vegetation dramatically alters water temperature, oxygen and chemical concentrations, and detrital and other resource availability, thereby threatening the persistence of aquatic macroinvertebrate and other species (e.g. van Biervliet et al. 2009). Furthermore, higher populations of vagile species growing and spreading in extensive degraded habitats increases the likelihood that they will reach, and become invasive in, distant habitats, threatening species and services in those ecosystems. The protection or restoration of patches and connectivity among native ecosystems is critical to the sustainability of populations and interactions necessary to maintain ecosystem services (Duffy 2009, R.H. Gibson et al. 2006, Greathouse et al. 2006, Landis et al. 2000, Steffan-Dewenter and Tschardtke 1999).

Xylophages may be particularly threatened as a result of deforestation, forest fragmentation, and conversion of landscapes dominated by old forests, with abundant woody litter, to landscapes dominated by young forests, with little woody litter accumulation (Grove 2002, Similä et al. 2002). Numerous wood-boring species became extinct as a result of the deforestation of Europe during the past 5000 yrs (Grove 2002). Loss or isolation

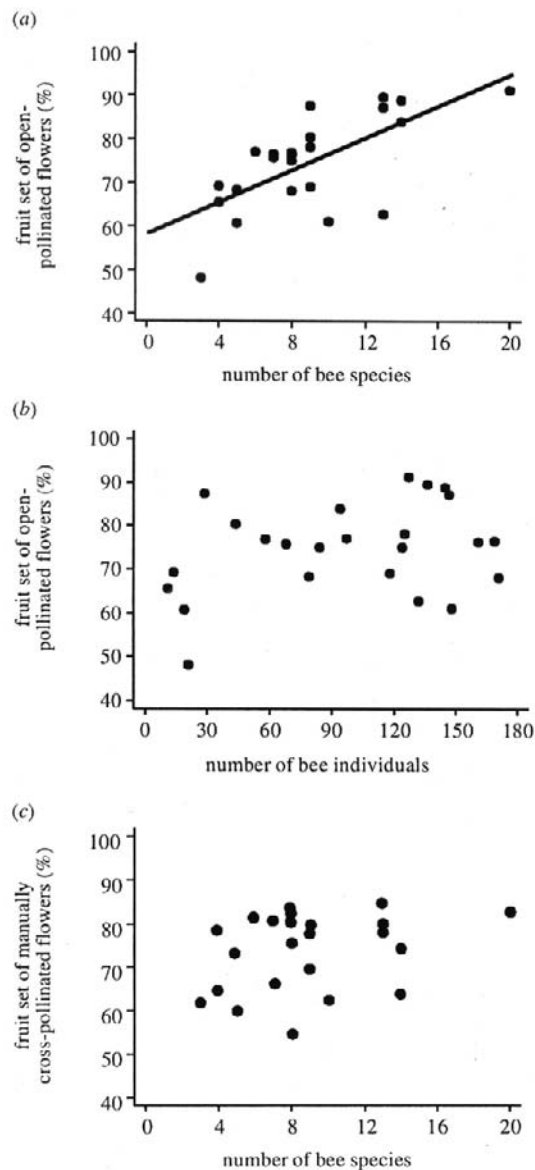
of key species at the landscape level could threaten the decomposition of woody residues in remnant natural areas. Loss of key carrion-feeders, such as the American burying beetle, would threaten the turnover of carrion, and potentially could create a public health hazard.

Similarly, the loss of specialized pollinators or seed dispersers, as a result of habitat fragmentation or competition from introduced honey bees, also threatens the reproduction and survival of their plant mutualists (Aizen and Feinsinger 1994, Bascombe 2009, Biesmeijer et al. 2006, R.H. Gibson et al. 2006, Hansen and Müller 2009, Powell and Powell 1987, Somanathan et al. 2004, Steffan-Dewenter and Tschardt 1999, Taki et al. 2007, Vamosi et al. 2006, C. Winter et al. 2008, see Chapter 13). Native bees are critical to the production of many plants, including agricultural crops, and are often capable of providing full pollination service in the absence of honey bees (Kremen et al. 2002), but their continued pollination service depends on proximity to, or corridors that provide access from, natural or semi-natural ecosystems that provide necessary habitat requirements (Fig. 16.9) (Holzschuh et al. 2007, A. Klein et al. 2003, Kremen 2005, Kremen et al. 2002, Ricketts 2004, Taki et al. 2007, N. Williams and Kremen 2007). Ants and ground beetles (Carabidae) are important predators in many ecosystems, but they are sensitive to changes in ecosystem conditions, especially those resulting from agricultural intensification, which potentially undermines their role as regulators of prey populations (A. Andersen and Majer 2004, Hassall et al. 1992, Landis et al. 2000, Marino and Landis 1996, Niemelä and Spence 1994, Niemelä et al. 1992, Thies and Tschardt 1999). Such groups should be targeted in conservation or restoration efforts.

Maintenance or recovery of endangered species requires attention to the size and distribution of nature reserves for remnant populations. The theory of island biogeography dominated conservation biology during the 1970s and 1980s, and continues to shape perspectives of nature reserves as habitat islands (e.g., Diamond and May 1981, L. Harris 1984). An early application of this theory was the development of rules for refuge design, such as the SLOSS (single large or several small) rule, based on the likelihood of colonization and persistence of large vs. small islands or patches. Diamond and May (1981) noted that the value of various options for species viability depended on the habitat area required by a species and its dispersal capability. Small organisms such as insects could persist longer in small reserves than could larger organisms. In fact, insects often can persist undetected on rare hosts in relatively small, isolated patches, as was the case for Fender's blue butterfly, *I. icarioides fenderi*, which was last seen in 1936 before being rediscovered in 1989 in small remnant patches of its host lupine, *Lupinus sulphureus kincaidii*, in western Oregon (M. Wilson et al. 1997). Nevertheless, species in disappearing habitats remain vulnerable to extinction (e.g., Lockwood and DeBrey 1990).

Metapopulation models are based on the landscape pattern of demes and gene flow among demes in a non-equilibrium landscape (Hanski and Simberloff 1997, Harrison and Taylor 1997). Small demes are the most vulnerable to local extinction, due to disturbances or land-use change, but their presence may be critical to the recolonization of vacant patches or to gene exchange with nearby demes. Dispersal among patches is critical to maintaining small demes and preventing or delaying local extinction. Clearly, population recovery for such species depends on the restoration or replacement of habitats.

Principles of metapopulation dynamics may be particularly important for the conservation and restoration of populations of entomophagous predators and parasites in agricultural landscapes. Predators and parasitoids are recognized as important natural agents of crop pest regulation, but as a group, they are particularly vulnerable to habitat



**FIG. 16.9** Fruit set of highland coffee, *Coffea arabica*, in relation to diversity and abundance of native bees in 24 agroforestry coffee fields in Indonesia during Nov 2000–Oct 2001. a) fruit set as a function of open-pollination and bee species richness ( $y = 59 + 1.8x$ ,  $r^2 = 0.45$ ,  $p < 0.001$ ). b) fruit set as a function of open-pollination and bee abundance ( $p = 0.13$ ). c) fruit set as a function of manual cross-pollination and bee species richness ( $p = 0.14$ ). From Klein et al. (2003) with permission from the authors and the Royal Society.

fragmentation (Kruess and Tschardt 1994, Schowalter 1995) and pesticide application (Sherratt and Jepson 1993). Hassell et al. (1991) and Sherratt and Jepson (1993) suggested that predator and parasite persistence in agroecosystems depends on the metapopulation dynamics of their prey, as well as on the frequency and distribution of pesticide use, and that connectivity between patches that were characterized by locally unstable

predator–prey interactions could allow mutual persistence. M. Thomas et al. (1992) found that creation of islands of grassland habitats in agricultural landscapes increased the abundances of several groups of entomophagous arthropods.

Restoration goals must address the appropriate site conditions. For example, the clearcut harvest, burning and planting of ponderosa pine, *Pinus ponderosa*, or Douglas-fir, *Pseudotsuga menziesii*, in western North America reflected an early perception of fire as a stand-replacing disturbance that created a mineral soil seed bed necessary for the establishment of even-aged forest. The resulting even-aged monocultures have supported nearly continuous insect outbreaks as these forests age. Research following natural fires demonstrated more complex effects of fire. Patches of surviving trees intermingled with patches that had been burned to mineral soil, resulting in uneven-aged forest structure as regeneration spread from refuges. Harvest alone, to create patchy landscapes, does not satisfy habitat requirements for many species (Gandhi et al. 2004). Consequently, current restoration efforts focus on thinning and prescribed fire to produce an uneven-aged forest structure, with wider tree spacing, often aided by insects (J. Stone et al. 1999). Insect outbreaks may increase the likelihood of fire, at least under some circumstances (Lynch et al. 2006), or function in the absence of fire to create the open-canopied patches that are required by some threatened species (Radeloff et al. 2000).

Planted seedlings may be insufficient, by themselves, for forest restoration on harsh sites. Amaranthus and Perry (1987) demonstrated that transfer of biologically-active soil (containing invertebrates and microorganisms) from established conifer forests or plantations significantly increased the survival and growth of seedlings on clearcut sites by up to 50%, compared to seedlings planted directly into clearcut soils, from which soil biota had disappeared as a result of exposure to heat and desiccation.

Similarly, flooding a depression is not sufficient for wetland restoration. Attention to the temporal patterns of surface and subsurface water flux and substrate conditions may be necessary for re-establishing a wetland community (Batzer and Wissinger 1996). For example, S.C. Brown et al. (1997) found that transplanting wetland soil resulted in significantly faster and more prolific plant growth and macroinvertebrate colonization in artificial wetlands. Wetlands are particularly vulnerable to sedimentation and to the concentration of agricultural chemicals draining from terrestrial habitats (Batzer and Wissinger 1996). Insects are useful indicators of wetland conditions and restoration success (Batzer and Wissinger 1996, see section V below).

Maintaining adequate riparian corridors may be equally important for the integrity of aquatic and terrestrial ecosystems. Riparian corridors filter terrestrial runoff that can alter conditions for aquatic communities. A number of studies have indicated that riparian zones at least 30 m wide may be necessary to prevent changes in water temperature and other conditions that would alter the aquatic ecosystem (Davies and Nelson 1994, Kiffney et al. 2003). Riparian vegetation represents an important source of terrestrially-derived invertebrates that compose at least 33% of the diet of young salmon (B. Allan et al. 2003, Baxter et al. 2005, Kawaguchi and Nakano 2001). Furthermore, riparian corridors facilitate the spread of terrestrial populations among suitable landscape patches. However, riparian corridors also represent unique, frequently-flooded habitats on the terrestrial landscape. Sabo et al. (2005) conducted a meta-analysis of the diversity of riparian plant and animal taxa on seven continents and discovered that riparian habitats do not just harbor larger numbers of species, but rather support significantly different species pools, increasing landscape diversity by 50% globally.

Restoration also must address the network of interactions among species that may be at least as important to restoration success as is attention to key species (Gratton and Denno 2006). For example, many plant species that are targeted for restoration cannot survive without associated pollinators and seed dispersers (Bascompte 2009, Biesmeijer et al. 2006), but these mutualists, in turn, depend on a diversity of plant species to maintain their populations (Bascompte 2009, Forup et al. 2008, R.H. Gibson et al. 2006, A. Klein et al. 2003, Kremen 2005, Kremen et al. 2007). Plants in diverse communities may be more vulnerable to declines in pollinator diversity and abundance, because of greater pollen limitation due to competition for remaining pollinators, compared to plants in less diverse communities (Vamosi et al. 2006).

With increasing urban development on a global scale, urban environments will have a growing effect on surrounding ecosystems, both those adjacent to urban centers that are subject to conversion and human intrusion and those further away that are influenced by pollution, heat exchange, and other products of the urban environment. However, urban parks and other open space, roadside corridors, stormwater drainage systems, and ground and rooftop gardens could be modified to serve some conservation purposes, e.g., by favoring native plants over exotic or invasive plants for landscaping (M.R. Hunter and Hunter 2008). Insects generally are not popular with the urban public, given the association of some groups with filth and spread of disease. However, butterflies, dragonflies, ladybird beetles and tiger beetles are widely appreciated, offering opportunities to use them as examples for educational programs that promote the importance of insects for maintenance of ecosystem services and that encourage stewardship of biodiversity and natural resources. For example, urban landscapes and private gardens that provide native host plants and floral resources for larval and adult butterflies could partially offset the loss of natural habitats. Mosquito control in or near aquatic habitats can be modified (e.g., using bacterial controls described above) to minimize effects on non-vector species and enhance natural regulation of vector populations.

Unfortunately, rapidly changing conditions at both local and regional levels may limit the options available for conservation and restoration. Changing public vision and environmental policy will be necessary to ensure ecosystem integrity and sustainability of ecosystem services globally.

#### IV. INVASIVE SPECIES

Invasive species are among the most serious threats to ecosystem services and restoration success. The costs of controlling damage by invasive species have been estimated at more than US\$100 billion in the U.S. (Pimentel et al. 2000). D. Johnson et al. (2006) reported that more than US\$194 million was spent on the monitoring and control of gypsy moth alone in the U.S. during 1985–2004. Cook et al. (2007) calculated that the continued exclusion of the varroa bee mite, *V. destructor*, from Australia for the next 30 years would prevent losses of US\$16–39 million yr<sup>-1</sup> in terms of reduced pollination service. Furthermore, desperate attempts to control invasive species with pesticides seriously interfere with more sustainable natural controls. Invasive species may be introduced passively, via storm winds or by hitchhiking on travelers or commercial shipments (Torres 1988), or actively, as ornamental or commercial products (C. Riley 1890). The gypsy moth and cynthia silkworm, *Samia cynthia*, were originally introduced into the U.S. as part of efforts to establish a silk industry (Andrews 1868, Forbush and Fernald 1896, C. Riley and Howard 1890). Honey bees have been transported widely by humans for honey production and

pollination services, but their presence in many regions has led to declines in native pollinator populations and in ineffective pollination of native plants that require more specialized pollinators (e.g., Aizen and Feinsinger 1994). Once established in new habitats, species that are freed from control by the predators and parasites that would regulate their population size in their native habitats can spread rapidly, i.e., the **Enemy Release Hypothesis** (J. Adams et al. 2009, D. Carpenter and Cappuccino 2005).

Insects may be among the solutions or may contribute to invasibility of other species, as well as being among the most serious invaders. For example, invasive plants often require the introduction of insect herbivores as biological control agents (e.g., D. Carpenter and Cappuccino 2005, R. Doyle et al. 2002, Louda et al. 2003, McEvoy et al. 1991, 1993), although native insect herbivores also can inhibit spread of invasive plants (N. Sanders et al. 2007). Insects may provide resources for invasive predators. Native charr in Japan derive 50% of their energy budget from terrestrial insects falling into streams (Baxter et al. 2007). An invasive trout reduced charr abundance by reducing availability of allochthonous insects by 75% (Baxter et al. 2007).

Invasive insects have created serious problems for ecosystem services and human health. Hemlock woolly adelgid, *Adelges tsugae*, threatens eastern hemlock, *Tsuga canadensis*, throughout the invaded range, causing a shift in forest composition from hemlock to angiosperms and a consequent increase in soil pH and altered biogeochemical cycling processes that threaten the suitability of the habitat for other species (Kizlinski et al. 2002, Orwig 2002). Invasive ants may be particularly disruptive to ecosystem structure and function, because of their complex interactions with a variety of other organisms (Neville et al. 2008, N. Sanders et al. 2003, see chapters 8, 13 and 14). Red imported fire ants, *Solenopsis invicta*, negatively affect populations of ground-nesting birds, small mammals and reptiles, and can discourage larger animals from entering infested areas (C. Allen et al. 2004, S. Porter and Savignano 1990). Hansen and Müller (2009) reported that an invasive ant, *Technomyrmex albipes*, interfered with the pollination and seed dispersal of an endangered plant, *Roussea simplex*, by endemic blue-tailed day-geckoes, *Phelsuma cepediana*, on the island of Mauritius. The Asian tiger mosquito, *Aedes albopictus*, introduced into North America in a shipment of used tires, vectors several diseases of birds and mammals (Meyerson and Reaser 2003, Turrell et al. 2005). Insect-vectored plague and West Nile virus, both exotic in North America, have decimated wildlife populations (Marra et al. 2004, Stapp et al. 2004), requiring control of vector or pathogen to ensure successful conservation or restoration of vulnerable species.

Too often, efforts to control invasive species are delayed until populations are established and growing exponentially in the absence of regulatory mechanisms. Low-density populations are vulnerable to extinction (the Allee effect, Chapter 6), particularly through failure to find potential mates (Contarini et al. 2009, Gascoigne et al. 2009, Kramer et al. 2009), making the pre-establishment period a window of opportunity to facilitate elimination (Yamanaka and Liebhold 2009).

Mating success can be reduced through sterile male release, mass trapping, or mating disruption techniques. Early detection of pre-established populations is critical to maximizing the time available to produce sterile males or develop the pheromones necessary for mass trapping or mating disruption. Yamanaka and Liebhold (2009) used computer models to predict eradication success for two insect “types”: 1) an insect that has a long reproductive period and is capable of multiple matings but has low daily reproductive rate, such as many Coleoptera, and 2) an insect that has a short reproductive period and is capable of mating only once per generation but has high reproductive rate, such as many

Lepidoptera. They found that sterile male release methods would be most effective for type 1 insects, and that mass-trapping would be most effective for type 2 insects, provided a sufficiently large number of female-baited traps could be installed. Mating disruption also would be effective for type 2 insects when sex attractants or pheromone-masking compounds can be identified. Yamanaka and Liebhold (2009) discovered that insect pests are more likely to be eradicated successfully than had been predicted previously by models that did not account for mating failure.

D. Johnson et al. (2006) found that invasive species often may spread through pulsed range expansion, i.e., regularly punctuated range expansions interspersed with periods of static distribution. This pattern could be explained by an interaction between Allee effects and stratified diffusion, a process whereby most individuals disperse locally, but a few individuals move long distances to initiate new colonies (see [Chapter 7](#)). These results suggested that invasion could be slowed considerably by suppressing population peaks along range borders.

However, the effects of invasive species should be evaluated carefully to avoid compounding the problems that they cause. Invasive species are not necessarily detrimental to restoration efforts and may, in some cases, contribute to restoration success (Ewel and Putz 2004, Lugo 2004). For example, invasive plant species may have unique abilities to restore soil structure and fertility, canopy cover and biodiversity on degraded sites (Ewel and Putz 2004, Lugo 2004). Introduction of biological control agents in such cases may have undesirable consequences for restoration of ecosystem services.

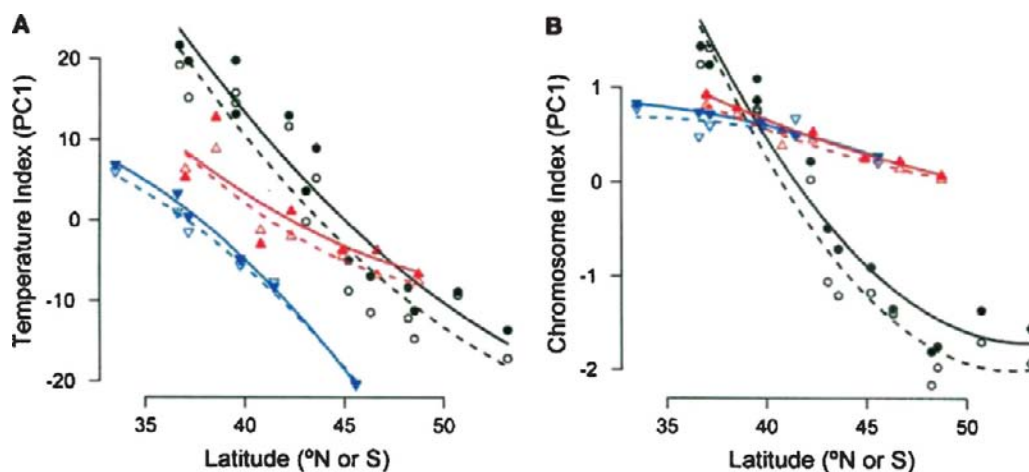
## V. INDICATORS OF ENVIRONMENTAL CONDITIONS

Insects are among the most useful indicators of changing conditions (Dufrêne and Legendre 1997, Maleque et al. 2009). Because of their short life spans, rapid reproductive rates and sensitivity to biochemical changes in their resources, insects provide early warning of changes that are not yet visible in the condition or abundance of larger, longer-lived plants or vertebrates, usually favored as bioindicators (Balanyá et al. 2006, Menéndez 2007).

Water yield and water quality are particularly important ecosystem services that are critical for the support of urban and agricultural production (Bonada et al. 2006, see above). Aquatic insects are sensitive to changes in water quality (particularly concentrations of oxygen and pollutants, see [Chapter 2](#)), making them particularly useful indicators of water quality (Bonada et al. 2006, C. Hawkins et al. 2000). For example, replacement of chironomid species that characterize oligo-mesotrophic conditions by species characterizing eutrophic conditions provided early indication of pollution in Lake Balaton, Hungary (Dévai and Moldován 1983, Ponyi et al. 1983).

Ant associations are used as indicators of ecosystem integrity and the status of restoration efforts in Australia (A. Andersen and Majer 2004). Similarly, grasshoppers ([Fig. 5.9](#)), dung beetles ([Fig. 9.6](#)), ground beetles, and xylophagous beetles can be used to assess ecosystem integrity and recovery status (Fielding and Brusven 1995, Grove 2002, B. Klein 1989, Maleque et al. 2009, Niemelä and Spence 1994, Niemelä et al. 1992). Insect herbivores could indicate changes in plant biochemistry before visible chlorosis or other symptoms of stress became apparent.

The succession of insect species in decomposing carcasses ([Figs. 10.4 and 10.5](#)) has been applied by law enforcement agencies to determine the time and circumstances of death (Byrd and Castner 2001, Goff 2000, K.G.V. Smith 1986, E. Watson and Carlton 2003). For example, fly colonization rate in a corpse differs between exposed or protected



**FIG. 16.10** Temporal shifts in temperature and chromosome inversion frequencies for *Drosophila subobscura* at 26 sites at different latitudes on three continents (black = European sites, red = North American sites, blue = South American sites). A) a climate temperature index is inversely correlated with latitude and has increased from historical (mean 24 yr previous, open symbols, dashed regression lines) to recent (1997–2004, filled symbols, solid regression lines) samples. B) a chromosome index is inversely correlated with latitude and also has increased from historical to contemporary samples. From Balanyá et al. (2006) with permission from AAA S.

locations. Research on the sequence and timing of colonization by various insect species on corpses under different environmental conditions provides critical evidence in criminal cases.

Insects also provide a useful indication of changing climate. Responses to elevated global temperatures include measureable shifts in the geographic ranges of species toward higher elevations and latitudes, earlier activity in spring as degree-day requirements are met earlier in the year, and measureable change in frequencies of genes conferring temperature tolerance. Menéndez (2007) analyzed distribution data for 1700 species of plants, insects and vertebrates and found a significant range shift, averaging  $6.1 \text{ km dec}^{-1}$  toward the poles (or  $\text{m dec}^{-1}$  upward in elevation) and significant advancement of spring events by 2–3 d  $\text{dec}^{-1}$ . Balanyá et al. (2006) compared genetic change and climate change for 26 populations of *Drosophila subobscura*, a cosmopolitan species, for which genetic composition has been known for, on average, 24 years (Fig. 16.10). Over this period, 22 of these populations experienced measureable warming, and 21 showed a shift toward the lower-latitude (warm-adapted) genotype. Both temperature and genetic shifts were equivalent to a  $1^\circ$  shift in latitude toward the Equator.

## VI. SUMMARY

Insect ecology provides a basis for managing complex, often complementary, effects on ecosystem services, such as resource production, cultural values, and supporting or regulating services. In addition to affecting the production of plant and animal sources of food, building materials, medical and industrial resources, insects themselves provide valuable food, silk and pharmaceutical products. They also affect cultural and recreational values, as well as supporting and regulating services that underlie resource production and



cultural values. Management decisions should be based on net benefits and costs of multiple effects on multiple services.

Application of insect ecology to the management of insects which are perceived to be pests has been a driving factor in scientific advances. Development of the integrated pest management (IPM) approach has emphasized the protection or augmentation of natural regulatory mechanisms to manage crop, forest, medical/veterinary, and urban pests and to minimize insect adaptation to particular control tactics. Whereas native species in natural ecosystems may represent important feedback regulation mechanisms, warranting little interference, invasive species in agroecosystems require intensive management efforts. A variety of cultural methods to modify host and habitat conditions can reduce the likelihood of pest outbreaks. Transgenic crop varieties, biological control, pheromones, and precision application techniques are available to reduce target insect population levels below resource injury thresholds and minimize the need for insecticides. Pest management requires evaluation of the benefit to ecosystem services and to effects on non-target species that may be critical to long-term sustainability of ecosystem services.

Few insects have been targeted for conservation efforts, but insects often affect the success of conservation and restoration programs focused on other taxa. Attention should be given to the availability of key pollinators and seed dispersers that may be necessary to the reproduction and recruitment of targeted plants. Insects also are critical food resources for insectivorous vertebrates. Retention of important insect functional groups, such as xylophages or carrion-feeders, in fragmented landscapes may be necessary to maintain ecosystem functions. Increasing urbanization of human populations affects surrounding ecosystems and the quality of urban life, but urban parks, roadside corridors, and private gardens could serve conservation purposes by offsetting habitat losses for threatened native species and communities.

Finally, the sensitivity of insects to environmental conditions has proven useful in assessing ecosystem conditions. Aquatic insects have been used widely as indicators of water quality. Ants, dung beetles and other terrestrial species have been used as indicators of the success of ecosystem restoration efforts. Carrion-feeders have been used by law enforcement officials to indicate the circumstances involved in the death of humans or wildlife. Insect responses to changes in temperature and other habitat variables also provide valuable early indications of global changes.

Insect ecology has demonstrated its value for managing insect populations, ecosystem conditions, and ecosystem services. An understanding of the ecological factors that affected boll weevil diapause and reproduction was critical to elimination of the boll weevil as a serious threat to cotton production in the southern U.S. The study of insect ecology will continue to provide the information that is necessary to manage insect populations, ecosystem conditions, and ecosystem services in a changing global environment.

# Summary and Synthesis

- I. Summary
- II. Synthesis
- III. Critical Issues
- IV. Conclusions

## INTRODUCTION

INSECT ECOLOGY INCLUDES BOTH INSECT ADAPTATIONS TO THEIR environment and their effects on environmental conditions. Insects represent the full scope of heterotrophic adaptive life history strategies, from sessile species whose ecological strategies resemble those of plants to social insects whose range of behavioral attributes resembles that of advanced vertebrates. The ability of insects to survive in some of the harshest environments on Earth, their capacity for dramatic population growth and their range of direct and indirect interactions with other species span the full range of ecological complexity. Their diversity brings them to the attention of biologists, natural resource managers, artists and amateur collectors. The first three sections in this book emphasize this traditional approach to the study of insect ecology.

Insect ecology also addresses their effects on ecosystem/environmental conditions. Insects, as well as other organisms, influence their environment in complex, and often dramatic, ways, earning many species the designation of “ecosystem engineers”. Foraging patterns affect their interactions with other organisms and the resulting distribution of resources. Population outbreaks of some herbivorous insects alter vegetation structure, biogeochemical cycles and climate. Natural selection represents feedback between ecosystem conditions and individual phenotypes that affect ecosystem variables. Other feedback mechanisms between individuals, populations, and communities can stabilize or destabilize ecosystem, landscape and global processes. Understanding these feedbacks is critical to the prediction of ecosystem (and insect) responses to environmental changes. Phytophages dramatically alter vegetation structure across landscapes and potentially affect global climate and biogeochemistry (Chapter 12). Termites account for substantial portions of global carbon flux (Chapter 14). Major advances have been made in recent decades in analyzing the potential ability of insects to stabilize primary production and other ecosystem services. This concluding chapter summarizes key ecological issues, synthesizes key integrating variables, and identifies critical issues for future study.

## I. SUMMARY

The hierarchical organization (Fig. 1.3) of this book emphasizes linkages and feedbacks among levels of ecological organization. Linkages and feedbacks are strongest between neighboring levels but are significant even between individual and ecosystem levels of the hierarchy. Physiological and behavioral responses to environmental variation are under genetic control and determine individual fitness, but they also affect the rate and geographic pattern of resource acquisition and allocation which, in turn, control climate and energy and biogeochemical fluxes at the ecosystem level. These feedbacks are an important and largely neglected aspect of insect ecology that affect ecosystem stability and global processes.

The geographic distribution of individual species generally reflects the environmental template established by continental history, latitude, mountain ranges and global atmospheric and oceanic circulation patterns. The great diversity of insects reflects their rapid adaptation to environmental variation, an ability conferred by small size, short life spans and rapid reproductive rates. These attributes have facilitated speciation at multiple scales: among geographic regions, habitats, resources, and at microscales on or within resources (e.g., individual leaves). However, within the potential geographic range of a species, the spatial and temporal patterns of abundance reflect disturbance dynamics, resource distribution, and interactions with other species that affect individual fitnesses and enhance or limit colonization and population growth.

Energy and resource budgets (Fig. 4.1) are key aspects of individual fitness, population persistence, and community interactions. All organisms require energy to accumulate the resources necessary for growth and reproduction, against resource concentration gradients, and thereby maintain the thermodynamic disequilibrium that is characteristic of life. Where resources are more concentrated relative to individual needs, less energy is required for their acquisition. Interactions among organisms often may be controlled by mass balances of multiple nutrients. Resource use requires adaptations in order to acquire necessary limiting nutrients, such as nitrogen, while avoiding or circumventing toxic or defensive chemicals, as well as overabundant nutrients.

Much research has addressed plant defenses against feeding by insects and other herbivores. Advances in molecular analysis have permitted the identification of genetic mechanisms that underly biochemical interactions between plants and herbivorous insects, including induction of specific chemical defenses and their communication to other plants. Insect herbivores have evolved a variety of mechanisms for avoiding, detoxifying, or inhibiting the expression of plant defenses in order to exploit plant resources. All insect species have mobile stages which are adapted to find new resources before current resources are depleted or destroyed. The early evolution of flight among insects greatly facilitated foraging, escape from unsuitable environmental or resource conditions, and the discovery of more optimal conditions. Individuals or populations that fail to acquire sufficient energy and nutrients to grow and reproduce do not survive.

Adaptations for detecting and acquiring resources are highly developed among insects. Many insects can detect the presence and location of resources from chemical cues which are carried at low concentrations on wind or water currents. The diversity of strategies among insect species for acquiring resources has perhaps drawn the most ecological attention. These strategies range from ambush to active foraging, often demonstrate considerable learning ability (especially among social insects), and involve insects in all types of interactions with other organisms, including competition (e.g., for food, shelter and oviposition site resources), predation and parasitism (on plant, invertebrate

and vertebrate prey or hosts and as prey or hosts), and mutualism (e.g., for protection, pollination and seed dispersal).

Spatial and temporal variation in population and community structure reflects the net effects of environmental conditions. Changes in population and community structure also constrain the survival and reproduction of associated species. Population density and competitive, predatory and mutualistic interactions affect foraging behavior and the energy and nutrient balances of individuals. Individuals that are forced to move constantly to avoid intra- or interspecific competitors or predators will be unable to forage sufficiently for energy and nutrient resources. On the other hand, energy and nutrient balances can be improved through mutualistic interactions that enhance the efficiency of resource acquisition. The relative contributions of intra- and interspecific interactions to individual survival and reproduction remain a central theme of ecology, but their study has been poorly integrated with ecosystem conditions. Debate over the importance of bottom-up vs. top-down controls of populations perhaps reflects variation in the contributions of these factors among species, as well as spatial and temporal variation in their effect.

Ecosystems represent the level at which complex feedbacks among abiotic and biotic processes are integrated. Ecosystems can be viewed as dynamic energy- and nutrient-processing engines that modify global energy and nutrient fluxes. Cycling and storage processes controlled by organisms reduce variation in abiotic conditions and resource availability. Although ecosystem properties are largely determined by the structure and composition of vegetation, insects and other animals modify ecosystem conditions, often dramatically, through their effects on primary production, decomposition and mineralization, and pedogenesis. The effects of herbivorous insects on vegetation structure affect albedo, evapotranspiration, and wind abatement. Changes in decomposition processes affect fluxes of carbon and trace gases, as well as soil structure and fertility. Insect roles as ecosystem engineers mitigate or exacerbate environmental changes which result from anthropogenic activities. Resolution of environmental issues requires attention to these roles of insects, as well as to their responses to environmental changes.

An ecosystem approach to insect ecology can aid management of ecosystem services. Agricultural and forest ecosystems have been manipulated for millenia to increase commodity production, but the density and extent of planted crops and breeding for desirable traits have promoted herbivore population growth and required intensive "pest" management efforts. Insects also provide pollination services and affect fish and wildlife, water yield, cultural and other ecosystem services. Recent approaches to managing insects that interfere with ecosystem services emphasize the identification and manipulation of factors affecting ecological interactions among primary production, herbivorous insects and various predators and parasites. Targeted insects quickly develop genetic resistance to insecticides or other management tactics to which they are exposed frequently and widely.

Many insects may be critical to ecosystem conservation or restoration efforts. Conservation and restoration programs have advanced beyond simple efforts to protect individual species, to recognition of the key contributions of associated plants, herbivores, pollinators, seed dispersers and decomposers to the sustainability of any conservation or restoration project. Finally, many insects have become valued tools for evaluating ecosystem conditions, based on their sensitivity to changes in those conditions that cause dramatic and measurable changes in abundance. Key species or functional groups appear to function as regulators of ecosystem processes that underlie the sustainability of ecosystem services.

## II. SYNTHESIS

Insect ecology addresses an astounding variety of interactions between insects and their environment. A unifying theme is the diversity of positive and negative, direct and indirect feedbacks that govern insect responses to environmental changes and their potential regulation of primary production, energy and nutrient fluxes and climate. Feedback integration among species and hierarchical levels occurs primarily through responses to variation in environmental conditions and functions to stabilize ecosystem conditions. Insect behavioral and physiological attributes that affect their interactions with all aspects of their environment are under genetic control. Evolution represents feedback on individual attributes that affect higher levels of organization.

The importance of environmental change and disturbance as a central theme in insect ecology has been recognized only recently. Disturbance, in particular, provides a context for understanding and predicting individual adaptations, population strategies, organization and succession of community types, and rates and regulation of ecosystem processes. Environmental changes or disturbances kill individuals or affect their activity and reproduction. Some populations are reduced to local extinction, but others exploit the altered conditions. Population strategies and interactions with other species also affect ecosystem properties in ways that increase the probability of disturbance (or other changes) or that mitigate environmental changes, and favor persistence of species less tolerant to change. Insects contribute greatly to the feedback between ecosystem properties and environmental variation. This aspect of insect ecology has important consequences for ecosystem responses to global changes resulting from anthropogenic activities.

Energy and biogeochemical fluxes integrate individuals, populations and communities with their abiotic environment. Energy flow and biogeochemical cycling processes determine rates and spatial patterns of resource availability. Many, perhaps most, species attributes can be shown to represent trade-offs between maximizing resource acquisition and optimizing resource allocation among metabolic pathways, e.g., foraging activity, defensive strategies, growth and reproduction. The patterns of energy and nutrient acquisition and allocation by individuals determine the patterns of storage and fluxes among populations, fluxes among species at the community level, and storage and flux at the ecosystem level that, in turn, feed back to determine resource availability for individuals, populations and communities. Resource availability is fundamental to ecosystem productivity and diversity. Resource limitation, including reduced availability resulting from inhibition of water and nutrient fluxes, is a key factor affecting species interactions. Herbivore and predator populations grow when increasing numbers of hosts or prey are available and/or are incapable of escape or defense because of insufficient resource acquisition or poor food quality.

Regulatory mechanisms emerge at all levels of the ecological hierarchy. Negative feedback and reciprocal cooperation are apparent at population, community and ecosystem levels. Cooperation benefits individuals by improving their ability to acquire limiting resources. This positive feedback balances the negative feedbacks that limit population density, growth and ecological processes. At the population level, positive and negative feedbacks maintain density within narrower ranges than occur when populations are released from these regulatory mechanisms. The responsiveness of insect herbivores to changes in plant density and condition, especially those resulting from crop management, introduction into new habitats, and land use, bring some species into conflict with human interests. However, insect outbreaks in natural ecosystems appear to be restricted in time and space and function to 1) maintain net primary production within relatively narrow

ranges imposed by the carrying capacity of the ecosystem and 2) facilitate replacement of plant species that are poorly adapted to current conditions by better adapted species. Regulatory capacity appears to reflect selection for recognition of cues that signal changes in host density or condition that affect long-term carrying capacity of the ecosystem.

The issue of ecosystem self-regulation is a key concept that significantly broadens the scope of insect ecology. Although this concept remains controversial, accumulating evidence supports a view that outbreaks of native insect species reduce long-term deviation in net primary production, at least in some ecosystems. Although outbreaks appear to increase short-term variation in some ecosystem parameters, in many cases outbreaks reverse unsustainable increases in NPP due to management practices (Fig. 15.10), and thereby reduce long-term variation in ecosystem conditions.

Models of group selection predict that stabilizing interactions are most likely in ecosystems where pairs or groups of organisms interact consistently. Hence, selection for stabilizing interactions might be least likely in ecosystems where such interactions are inconsistent, such as in harsh or frequently disturbed environments. However, selection for stabilizing interactions also might be less direct in productive, highly diverse, ecosystems with little variation in abiotic conditions or resource availability, such as tropical rain forests. Stabilizing interactions are most likely in those ecosystems where selection would favor co-evolution of interactions to reduce moderate levels of variation in abiotic conditions or resource availability. Research on stabilizing interactions should focus on these ecosystems.

### III. CRITICAL ISSUES

Agrawal et al. (2007) proposed three core areas for future research in ecology: 1) evaluating and predicting strength and context dependence of species interactions (both direct and indirect) across multiple scales, 2) identifying and measuring feedbacks between individual and multiple interactions and ecosystem dynamics, and 3) linking spatial and temporal patterns and processes to understand species evolution and coexistence. Advances in understanding of factors that control patterns of species diversity, community assembly and feedbacks between insects and ecosystem dynamics will improve prediction of species' (including insects') responses to various environmental changes and resulting changes in biotic control of ecosystem structure, function and services.

Resolution of the debate over regulation of ecosystem processes by herbivorous insects may not be possible, given the need for large scale manipulation of insect populations and long-term, multidisciplinary comparison of ecosystem processes that are necessary to test this hypothesis, within the context of rapid anthropogenic changes in the global environment. However, our perspective of insect effects determines our management approaches. Research clearly is needed to evaluate the long-term effects of outbreaks on primary production, soil conditions and sustainability of ecosystem functions and services. In particular, identifying factors underlying compensatory growth would clarify necessary conditions and contributions to long-term primary production in natural systems. Effects of population changes on mass balances of energy and nutrient fluxes may mitigate or exacerbate effects of acid rain, carbon flux, and other processes that affect global change. Understanding the extent to which outbreaks modify local climate and disturbance dynamics also would

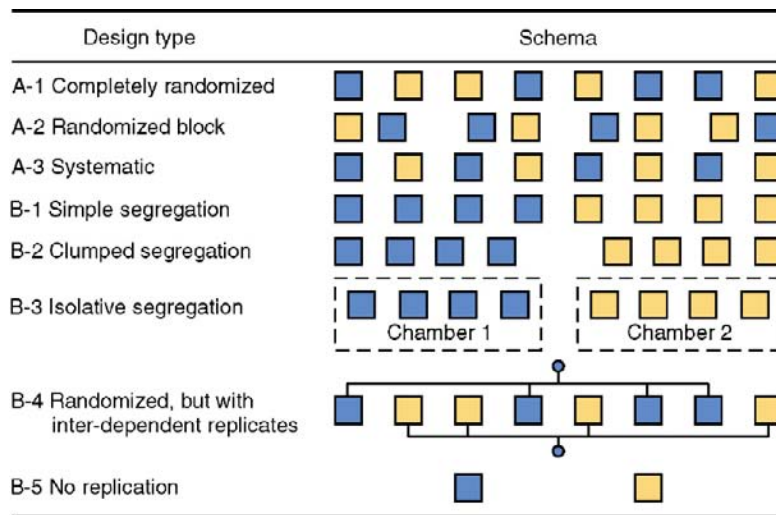
improve prediction of consequences of global changes. A number of long-term ecosystem research platforms are available for this research, including Long-Term Ecological Research (LTER) sites and National Environmental Observatory Network (NEON) sites in North America.

Predicting and alleviating effects of anthropogenic changes requires an understanding of insect roles and how these roles affect ecosystem responses to anthropogenic changes. Such changes will continue to trigger insect outbreaks, whether as destructive events or regulatory responses. Land use, in particular, affects patch structure and interactions among demes, greatly altering the spatial and temporal patterns of insect abundances. Ruderal plant species, valued for crop production but also adapted for rapid colonization of new habitats, are increasingly likely to dominate fragmented landscapes. The rapid growth and poor competitive ability of these species in crowded ecosystems make them targets for their associated insects. Such ecosystems will require constant human intervention. Protection or restoration of natural ecosystems will require attention to interactions necessary to maintain key species, including pollinators, seed dispersers, and decomposers.

Accomplishment of these objectives requires that research approaches be broadened, in order to address the direct and indirect effects of insects on ecosystem structure and function. This, in turn, requires changes in research approaches and integration of population and ecosystem models. Testing of ecosystem-level hypotheses involves different approaches than does the testing of population and community-level hypotheses. At least three considerations are particularly important.

First, advances in insect ecology require attention to quantitative, as well as qualitative, methodology to test key hypotheses. Experimental design must address the statistical independence of samples. Whereas individuals within populations can serve as replicates for population and community properties, data must be pooled at the site (ecosystem) level for comparison of ecosystem variables. Ecosystem studies often have provided inconclusive data, because a single site representing each of several ecosystem types or experimental treatments (e.g., Fig. 17.1 B1–2) provides no error degrees of freedom for statistical analysis. Multiple samples collected within each site are not statistically independent (Hurlbert 1984). Furthermore, treatment effects are subject to the confounding effects of geographic gradients between treatment plots. Therefore, experimental designs must incorporate multiple, geographically interspersed, replicate sites to represent each ecosystem type or treatment (Fig. 17.1 A1–3). A larger number of replicate sites provides a greater range of inference than do multiple samples within sites (that must be pooled for statistical analysis), requiring a trade-off in sampling effort within and between sites.

Second, research to evaluate insect responses to, or effects on, ecosystem conditions should address a greater range of ecosystem variables than has been common in past studies of insect ecology. Insects respond to multiple factors simultaneously, not just one or a few factors that are subject to experimental manipulation, and their responses reflect trade-offs that might not be represented in studies that control a limited number of factors. A greater breadth of parameters can be addressed through multidisciplinary research, with experts on different aspects of ecosystems contributing to a common goal (Fig. 17.2). The involvement of insect ecologists in established multidisciplinary projects, such as the International Long Term Ecological Research (ILTER) sites in many countries, can facilitate the integration of insect ecology and ecosystem ecology. Specifically, insect ecologists can contribute to such programs by clarifying how particular species respond to, and shape, ecosystem conditions, including vegetation structure, soil properties,



**FIG. 17.1** Three representations (A 1–3) of acceptable experimental designs with interspersed, independent replicates of two treatments (blue vs. yellow boxes) and five representations (B 1–5) of experimental designs in which the principle of interspersed, independent replicates can be violated. From Hurlbert (1984) with permission from the Ecological Society of America.

biogeochemical cycling processes, etc., as described in Chapters 12–14, how insects affect the balance of nutrient fluxes within and between ecosystems (e.g., from aquatic to terrestrial ecosystems or across landscapes as populations move or expand, as described in Chapter 7), and how the diversity of species within guilds or functional groups affects the reliability of community organization and processes (Chapter 15).

Third, the spatial and temporal scales of research and perspectives must be broadened. Most studies of ecosystems address processes at relatively small spatial and temporal scales. However, population dynamics and capacity to influence ecosystem and global properties span landscape and watershed scales, at least. Feedbacks often may be delayed, or operate over long time periods, especially in ecosystems with substantial buffering capacity, requiring long-term institutional and financial commitments to study them adequately. Linkage of population and ecosystem variables using remote sensing and GIS techniques will become an increasingly important aspect of insect ecology. Nevertheless, ecosystems with large biomass or high complexity require simplified field mesocosms or modeling approaches to test some hypotheses.

The complexity of ecosystem interactions and information linkages has limited the level of detail, such as population dynamics, that can be incorporated in ecosystem models. Modeling methodology for ecosystem description and prediction is necessarily simplified, relative to that for population models. However, population models have largely ignored feedbacks between population and ecosystem processes. Hierarchical structure in ecosystem models facilitates the integration of more detailed insect population (and other) submodels, and their linkages and feedbacks with other levels, as data become available (Fig. 11.15).

Several ecosystem components should be given special attention. Subterranean and forest canopy subsystems represent two ecological frontiers. Logistical difficulties in gaining non-destructive or non-intrusive access to these two subsystems have limited





**FIG. 17.2** Interdisciplinary research on insect effects on woody litter decomposition at the H.J. Andrews Experimental Forest Long Term Ecological Research Site in western Oregon, U.S. A) logs tented to exclude wood boring insects during the first year of decomposition; B) logs inoculated with different initial heterotroph communities (bark vs. wood-borer, mold vs. decay fungi; ribbon color indicates inoculation treatment; plastic shelters reduced wood moisture relative to unsheltered logs). Data loggers at each replicate site measured ambient temperature and relative humidity and vertical and horizontal temperature and moisture profiles in logs. Sticky screens were used to measure insect colonization, emergence traps were used to measure insect emigration, PVC chambers were used to measure  $\text{CO}_2$  flux, and funnels under logs were used to measure water and nutrient flux out of logs. Scheduled destructive sampling of logs provided data on changes in wood density, excavation by insects, and nutrient content. See Barker (2008), Harmon et al. (1994) and Progar et al. (2000).

the data that are available for evaluating insect effects on canopy–atmosphere and canopy–rhizosphere–soil interactions that control climate and energy and matter fluxes. Improved canopy access methods, such as construction cranes (Fig. 17.3) for ecological use (Schowalter and Ganio 1998, D. Shaw 1998, 2004) and rhizotron technology (Sackville Hamilton et al. 1991, Sword 1998) offer opportunities for scientific advances in the structure and function of these subsystems.

Finally, the principles of insect ecology must be applied to improved management of insect populations and ecosystem resources. Ecosystem engineering can make crop systems more or less conducive to insect population irruptions. Alternative cropping systems include protection of soil systems to enhance energy and matter availability, polyculture cropping, and landscape patterns of crop patches and remnant native vegetation (Fig. 16.5) to restrict herbivore dispersal among hosts or patches (Altieri 2002, Coleman



**FIG. 17.3** Canopy cranes are a relatively new tool for experimental access to forest canopies. For example, the gondola of the Wind River Canopy Crane (75 m tall tower, 84 m long jib) can access 700,000 m<sup>3</sup> of 60 m tall canopy, as well as the canopy–atmosphere interface, over a 2.3 ha area in a 500-yr-old *Pseudotsuga/Tsuga* forest in southwestern Washington, U.S. Photo by J.F. Franklin, Reprinted from D. Shaw, (2004) with permission from Elsevier.

et al. 1992, Denys and Tschardtke 2002, Gliessman 2007, Isaacs et al. 2009, Kogan 1998, Kogan and Jepson 2007, Landis et al. 2000, 2005, Lowrance et al. 1984, Nicholls and Altieri 2007, Pretty et al. 2003, Rickson and Rickson 1998, S. Risch 1980, 1981, Thies et al. 2003, Tschardtke et al. 2005, 2007, Vincent et al. 2003, H. Zhou et al. 2009). These cropping systems also enhance conditions for predators that control potentially irruptive insect species. Promotion of interactions that tend to stabilize populations of irruptive species is more effective in the long term than is a reliance on pesticides or genetically-engineered crops. Examples include ant-attracting plants, provision or retention of hedgerows, or other refuges within agricultural landscapes that maintain predator populations (Kruess and Tschardtke 1994, Rickson and Rickson 1998). Furthermore, the effects of insects on ecosystems, including agroecosystems, are complex. Net effects of outbreaks on multiple parameters should be considered in deciding whether or not to suppress an outbreak. Given that outbreaks often reflect simplification of ecosystem conditions and can function to restore complexity and, perhaps, stability, control of native species in natural ecosystems may be counterproductive. Letting outbreaks of native species run their course could serve management purposes under some conditions.

Invasive species present serious challenges. Regulatory mechanisms in ecosystems have little effect on such species, which can have devastating direct and indirect effects on resource distribution, food web interactions and ecosystem conditions. Although some invasive species may replace some effects of native species that have been lost (e.g., Ewel and Putz 2004), rates and seasonal patterns will be altered. The threats of invasive species to ecosystem services warrant increased attention to preventing introductions and increased efforts to eliminate exotic species before they become established. Small populations are vulnerable to eradication through mating disruption with pheromones or sterile-mate releases (Yamanaka and Liebhold 2009), techniques that are less disruptive to other ecosystem components than are insecticides or biological control introductions. More disruptive techniques become necessary to control established populations. This will require early detection, rapid assessment of vulnerability and commitment by management agencies to act at this stage.

#### IV. CONCLUSIONS

Insects are involved in virtually all types of interactions and processes of terrestrial and freshwater ecosystems. Current environmental issues involve insects directly or indirectly, either in their capacity to respond to environmental changes or their capacity to alter ecosystem conditions. Therefore, insect ecology is fundamental to our ability to understand ecosystem structure and function and to solve environmental problems.

The hierarchical ecosystem approach to insect ecology emphasizes linkages and feedbacks among individual, population, community and ecosystem levels and clarifies the basis and consequences of insect adaptive strategies. This approach also indicates which level best addresses environmental problems. For example, if the issue is factors controlling plant susceptibility to herbivores, then individual responses to environmental cues are the appropriate focus. If the issue is the spread of exotic species, or restoration of native species, then metapopulation dynamics and regulatory interactions within communities are the levels of focus. If the issue is factors that affect global mass balances of carbon fluxes, then mass balances at the ecosystem level are the appropriate focus.

Our most significant scientific advances in the next decades will be in demonstrating the degree to which species interactions in ecosystems modify environmental conditions

and persist in the face of changing global conditions. Insects are major contributors to the ways in which ecosystems modify local and global conditions. Natural selection can be viewed as a major form of feedback between ecosystem conditions and individual adaptations that modify or stabilize ecosystem parameters. The degree to which insects regulate ecosystem parameters remains a key issue in global change biology and one that significantly broadens the scope and value of insect ecology.

This page intentionally left blank

# BIBLIOGRAPHY

---

- Abrams, P.A. 2001. Describing and quantifying interspecific interactions: a commentary on recent approaches. *Oikos* 94:209–218.
- Ackerman, A.S., O.B. Toon, D.E. Stevens, A.J. Heymsfield, V. Ramanathan, and E.J. Welton. 2000. Reduction of tropical cloudiness by soot. *Science* 288:1042–1047.
- Ackerman, I.L., W.G. Teixeira, S.J. Riha, J. Lehmann, and E.C.M. Fernandes. 2007. The impact of mound-building termites on surface soil properties in a secondary forest of central Amazonia. *Applied Soil Ecology* 37:267–276.
- Adams, J.M., W. Fang, R.M. Callaway, D. Cipollini, and E. Newell. Transatlantic Acer Platanoides Invasion Network, 2009. A cross-continental test of enemy release hypothesis: leaf herbivory on *Acer platanoides* (L.) is three times lower in North America than in its native Europe. *Biological Invasions* 11:1005–1016.
- Adams, T.S., and R.W. Sterner. 2000. The effect of dietary nitrogen content on trophic level <sup>15</sup>N enrichment. *Limnology and Oceanography* 45:601–607.
- Adler, L.S., R. Karban, and S.Y. Strauss. 2001. Direct and indirect effects of alkaloids on plant fitness via herbivory and pollination. *Ecology* 82:2032–2044.
- Adler, P.H., and J.W. McCreddie. 1997. The hidden ecology of black flies: sibling species and ecological scale. *American Entomologist* 43:153–161.
- Aerts, R. 1997. Climate, leaf litter chemistry and leaf litter decomposition in terrestrial ecosystems: a triangular relationship. *Oikos* 79:439–449.
- Agee, J.K. 1993. Fire Ecology of Pacific Northwest Forests. Island Press, Washington, DC.
- Agrawal, A.A., and M. Fishbein. 2008. Phylogenetic escalation and decline of plant defense strategies. *Proceedings of the National Academy of Sciences, USA* 105:10057–10060.
- Agrawal, A.A., and K. Konno. 2009. Latex: a model for understanding mechanisms, ecology, and evolution of plant defense against herbivory. *Annual Review of Ecology, Evolution and Systematics* 40:311–331.
- Agrawal, A.A., D.D. Ackerly, F. Adler, A.E. Arnold, C. Cáceres, D.F. Doak, E. Post, P.J. Hudson, J. Maron, K.A. Mooney, M. Power, D. Schemske, J. Stachowicz, S. Strauss, M.G. Turner, and E. Werner. 2007. Filling key gaps in population and community ecology. *Frontiers in Ecology and the Environment* 5:145–152.
- Ågren, G.I., E. Bosatta, and J. Balesdent. 1996. Isotope discrimination during decomposition of organic matter: a theoretical analysis. *Soil Science Society of America Journal* 60:1121–1126.
- Agustí, N., J. Aramburu, and R. Gabarra. 1999a. Immunological detection of *Helicoverpa armigera* (Lepidoptera: Noctuidae) ingested by heteropteran predators: time-related decay and effect of meal size on detection period. *Annals of the Entomological Society of America* 92:56–62.
- Agustí, N., M.C. de Vicente, and R. Gabarra. 1999b. Development of sequence amplified characterized region (SCAR) markers of *Helicoverpa armigera*: a new polymerase chain reaction-based technique for predator gut analysis. *Molecular Ecology* 8:1467–1474.
- Aide, T.M. 1992. Dry season leaf production: an escape from herbivory. *Biotropica* 24:532–537.
- Aide, T.M. 1993. Patterns of leaf development and herbivory in a tropical understory community. *Ecology* 74:455–466.
- Aide, T.M., and J.K. Zimmerman. 1990. Patterns of insect herbivory, growth, and survivorship in juveniles of a neotropical liana. *Ecology* 71:1412–1421.
- Aizen, M.A., and P. Feinsinger. 1994. Habitat fragmentation, native insect pollinators, and feral hon-

- ey bees in Argentine 'Chaco Serano'. *Ecological Applications* 4:378–392.
- Akiyama, T., S. Takahashi, M. Shiyomi, and T. Okubo. 1984. Energy flow at the producer level: the energy dynamics of grazed grassland 1. *Oikos* 42:129–137.
- Alfaro, C., V. Navarro-Llopis, and J. Primo. 2009. Optimization of pheromone dispenser density for managing the rice striped stem borer, *Chilo suppressalis* (Walker), by mating disruption. *Crop Protection* 28:567–572.
- Alfaro, R.I., and R.F. Shepherd. 1991. Tree-ring growth of interior Douglas-fir after one year's defoliation by Douglas-fir tussock moth. *Forest Science* 37:959–964.
- Algar, A.C., J.T. Kerr, and D.J. Currie. 2007. A test of Metabolic Theory as the mechanism underlying broad-scale species-richness gradients. *Global Ecology and Biogeography* 16:170–178.
- Allan, B.F., R.B. Langerhans, W.A. Ryberg, W.J. Landesman, N.W. Griffin, R.S. Katz, B.J. Oberle, M.R. Schutzenhofer, K.N. Smyth, A. de, St. Maurice, L. Clark, K.R. Crooks, D.E. Hernandez, R.G. McLean, R.S. Ostfeld, and J.M. Chase. 2009. Ecological correlates of risk and incidence of West Nile virus in the United States. *Oecologia* 158:699–708.
- Allan, J.D., M.S. Wipfli, J.P. Caouette, A. Prussian, and J. Rodgers. 2003. Influence of streamside vegetation on inputs of terrestrial invertebrates to salmonid food webs. *Canadian Journal of Fisheries and Aquatic Sciences* 60:309–320.
- Allee, W.C. 1931. *Animal Aggregations: a Study in General Sociology*. University of Chicago Press, Chicago, IL.
- Allen, A.P., J.H. Brown, and J.F. Gillooly. 2002. Global biodiversity, biochemical kinetics, and the energetic-equivalence rule. *Science* 297:1545–1548.
- Allen, C.R., D.M. Epperson, and A.S. Garmestani. 2004. Red imported fire ant impacts on wildlife: a decade of research. *American Midland Naturalist* 152:88–103.
- Allen, E.B., and M.F. Allen. 1990. The mediation of competition by mycorrhizae in successional and patchy environments. In *Perspectives on Plant Competition* (J.B. Grace, and D. Tilman, Eds.), pp. 367–389. Academic Press, San Diego, CA.
- Alstad, D.N., and D.A. Andow. 1995. Managing the evolution of insect resistance to transgenic plants. *Science* 268:1894–1896.
- Alstad, D.N., G.F. Edmunds, Jr., and L.H. Weinstein. 1982. Effects of air pollutants on insect populations. *Annual Review of Entomology* 27:369–384.
- Altieri, M.A. 2002. Agroecology: the science of natural resource management for poor farmers in marginal environments. *Agriculture, Ecosystems and Environment* 93:1–24.
- Altizer, S.M., K. Oberhauser, and L.P. Brower. 2000. Associations between host migration and the prevalence of a protozoan parasite in natural populations of adult monarch butterflies. *Ecological Entomology* 25:125–139.
- Amaranthus, M.P., and D.A. Perry. 1987. Effect of soil transfer on ectomycorrhiza formation and the survival and growth of conifer seedlings on old, non-reforested clear-cuts. *Canadian Journal of Forest Research* 17:944–950.
- Amman, G.D., M.D. McGregor, R.F. Schmitz, and R.D. Oakes. 1988. Susceptibility of lodgepole pine to infestation by mountain pine beetles following partial cutting of stands. *Canadian Journal of Forest Research* 18:688–695.
- Amoo, A.O.J., O.O. Dipeolu, P.B. Capstick, D.M. Munyinyi, L.N. Gichuru, and T.R. Odhiambo. 1993. Ixodid ticks (Acari: Ixodidae) and livestock production: effect of varying acaricide treatments on ticks and productivity in east coast fever-immunized weaner and dairy cattle. *Journal of Medical Entomology* 30:503–512.
- Andersen, A.N. 1988. Soil of the nest-mound of the seed-dispersing ant, *Aphaenogaster longiceps*, enhances seedling growth. *Australian Journal of Ecology* 13:469–471.
- Andersen, A.N., and W.M. Lonsdale. 1990. Herbivory by insects in Australian tropical savannas: a review. *Journal of Biogeography* 17:433–444.
- Andersen, A.N., and J.D. Majer. 2004. Ants show the way Down Under: invertebrates as bioindicators in land management. *Frontiers in Ecology and the Environment* 2:291–298.
- Andersen, D.C., and J.A. MacMahon. 1985. Plant succession following the Mount St. Helens volcanic eruption: facilitation by a burrowing rodent, *Thomomys talpoides*. *American Midland Naturalist* 114:63–69.
- Andersen, P.C., B.V. Brodbeck, and R.F. Mizell, III. 1992. Feeding by the leafhopper, *Homalodisca coagulata*, in relation to xylem fluid chemistry and tension. *Journal of Insect Physiology* 38:611–622.
- Anderson, J.M. 1988. Invertebrate-mediated transport processes in soils. *Agriculture, Ecosystems and Environment* 24:5–19.
- Anderson, J.M., and M.J. Swift. 1983. Decomposition in tropical forests. In *Tropical Rain Forest: Ecology and Management* (S.L. Sutton, T.C. Whitmore, and A.C. Chadwick, Eds.), pp. 287–309. Blackwell, London.
- Anderson, J.M., J. Proctor, and H.W. Vailack. 1983. Ecological studies in four contrasting lowland rain forests in Gunung Mulu National Park, Sarawak. *Journal of Ecology* 71:503–527.
- Anderson, K.E., B.D. Inouye, and N. Underwood. 2009. Modeling herbivore competition mediated by inducible changes in plant quality. *Oikos* 118:1633–1646.
- Anderson, N.H., R.J. Steedman, and T. Dudley. 1984. Patterns of exploitation by stream invertebrates of wood debris (xylophagy). *Verhandlungen der Internationalen Vereinigung für Theoretische und Angewandte Limnologie* 22:1847–1852.

- Anderson, V.J., and D.D. Briske. 1995. Herbivore-induced species replacement in grasslands: is it driven by herbivory tolerance or avoidance? *Ecological Applications* 5:1014–1024.
- Andrae, M.O., D. Rosenfeld, P. Artaxo, A.A. Costa, G.P. Frank, K.M. Longo, and M.A.F. Silva-Dias. 2004. Smoking rain clouds over the Amazon. *Science* 303:1337–1342.
- Andresen, E. 2002. Dung beetles in a central Amazonian rainforest and their ecological role as secondary seed dispersers. *Ecological Entomology* 27:257–270.
- Andresen, E., and S.G.W. Laurance. 2007. Possible indirect effects of mammal hunting on dung beetle assemblages in Panama. *Biotropica* 39:141–146.
- Andreux, F., C. Cerri, P.B. Vose, and V.A. Vitorello. 1990. Potential of stable isotope,  $^{15}\text{N}$  and  $^{13}\text{C}$ , methods for determining input and turnover in soils. In *Nutrient Cycling in Terrestrial Ecosystems: Field Methods, Application and Interpretation* (A.F. Harrison, P. Ineson, and O.W. Heal, Eds.), pp. 259–275. Elsevier, London.
- Andrewartha, H.G., and L.C. Birch. 1954. *The Distribution and Abundance of Animals*. University of Chicago, Chicago, IL.
- Andrews, W.V. 1868. The Cynthia silk-worm. *American Naturalist* 2:311–320.
- Anelli, C.M., and D.A. Prischmann-Voldseth. 2009. Silk batik using beeswax and cochineal dye: an interdisciplinary approach to teaching entomology. *American Entomologist* 55:95–105.
- Anstey, M.L., S.M. Rogers, S.R. Ott, M. Burrows, and S.J. Simpson. 2009. Serotonin mediates behavioral gregarization underlying swarm formation in desert locusts. *Science* 323:627–630.
- Appanah, S. 1990. Plant–pollinator interactions in Malaysian rain forests. In *Reproductive Ecology of Tropical Forest Plants* (K. Bawa, and M. Hadley, Eds.), pp. 85–100. UNESCO/Parthenon, Paris.
- Aranibar, J.N., J.A. Berry, W.J. Riley, D.E. Pataki, B.E. Law, and J.R. Ehleringer. 2006. Combining meteorology, eddy fluxes, isotope measurements, and modeling to understand environmental controls of carbon isotope discrimination at the canopy scale. *Global Change Biology* 12:710–730.
- Archer, S., and D.A. Pyke. 1991. Plant–animal interactions affecting plant establishment and persistence on revegetated rangeland. *Journal of Range Management* 44:558–565.
- Ardón, M., and C.M. Pringle. 2008. Do secondary compounds inhibit microbial- and insect-mediated leaf breakdown in a tropical rainforest stream, Puerto Rico? *Oecologia* 155:311–323.
- Arim, M., and P.A. Marquert. 2004. Intraguild predation: a widespread interaction related to species biology. *Ecology Letters* 7:557–564.
- Arnfield, A.J. 2003. Two decades of urban climate research: a review of turbulence, exchanges of energy and water, and the urban heat island. *International Journal of Climatology* 23:1–26.
- Arnone, III, J.A., J.G. Zaller, C. Ziegler, H. Zandt, and C. Körner. 1995. Leaf quality and insect herbivory in model tropical plant communities after long-term exposure to elevated atmospheric  $\text{CO}_2$ . *Oecologia* 104:72–78.
- Asquith, N.M., J. Terbourgh, A.E. Arnold, and C.M. Riveros. 1999. The fruits the agouti ate: *Hymenaea courbaril* seed fate when its disperser is absent. *Journal of Tropical Ecology* 15:229–235.
- Auclair, J.L. 1958. Honeydew excretion in the pea aphid *Acyrtosiphum pisum* (Harr.) (Homoptera: Aphididae). *Journal of Insect Physiology* 2:330–337.
- Auclair, J.L. 1959. Feeding and excretion of the pea aphid, *Acyrtosiphum pisum* (Harr.), reared on different varieties of peas. *Entomologia Experimentalis et Applicata* 2:279–286.
- Auclair, J.L. 1965. Feeding and nutrition of the pea aphid, *Acyrtosiphum pisum* (Harr.) (Homoptera: Aphididae), on chemically defined diets of various pH and nutrient levels. *Annals of the Entomological Society of America* 58:855–875.
- Ausmus, B.S. 1977. Regulation of wood decomposition rates by arthropod and annelid populations. *Ecological Bulletin (Stockholm)* 25:180–192.
- Autry, A.R., and J.W. Fitzgerald. 1993. Relationship between microbial activity, biomass and organosulfur formation in forest soil. *Soil Biology and Biochemistry* 25:33–39.
- Axelrod, R., and W.D. Hamilton. 1981. The evolution of cooperation. *Science* 211:1390–1396.
- Ayres, E., K.M. Dromph, R. Cook, N. Ostle, and R.D. Bardgett. 2007. The influence of below-ground herbivory and defoliation of a legume on nitrogen transfer to neighbouring plants. *Functional Ecology* 21:256–263.
- Ayres, M.P., R.T. Wilkens, J.J. Ruel, M.J. Lombardero, and E. Vallery. 2000. Nitrogen budgets of phloem-feeding bark beetles with and without symbiotic fungi. *Ecology* 81:2198–2210.
- Bach, C.E. 1990. Plant successional stage and insect herbivory: flea beetles on sand-dune willow. *Ecology* 71:598–609.
- Bailey, J.K., J.A. Schweitzer, B.J. Rehill, R.L. Lindroth, G.D. Martinsen, and T.G. Whitham. 2004. Beavers as molecular geneticists: a genetic basis to the foraging of an ecosystem engineer. *Ecology* 85:603–608.
- Baker, R.R. 1972. Territorial behaviour of the nymphalid butterflies, *Aglais urticae* (L.) and *Inachis io* (L.). *Journal of Animal Ecology* 41:453–469.
- Balanyá, J., J.M. Oller, R.B. Huey, G.W. Gilchrist, and L. Serra. 2006. Global genetic change tracks global climate warming in *Drosophila subobscura*. *Science* 313:1773–1775.
- Baldwin, D.H., J.A. Spromberg, T.K. Collier, and N.L. Scholz. 2009. A fish of many scales: extrapolating



- sublethal pesticide exposures to the productivity of wild salmon populations. *Ecological Applications* 19:2004–2115.
- Baldwin, I.T. 1990. Herbivory simulations in ecological research. *Trends in Ecology and Evolution* 5:91–93.
- Baldwin, I.T. 1998. Jasmonate-induced responses are costly but benefit plants under attack in native populations. *Proceedings of the National Academy of Sciences, USA* 95:8113–8118.
- Baldwin, I.T., and J.C. Schultz. 1983. Rapid changes in tree leaf chemistry induced by damage: evidence for communication between plants. *Science* 221:277–279.
- Bale, J.S., G.J. Masters, I.D. Hodkinson, C. Awmack, T.M. Bezemer, V.K. Brown, J. Butterfield, A. Buse, J.C. Coulson, J. Farrar, J.E.G. Good, R. Harrington, S. Hartley, T.H. Jones, R.L. Lindroth, M.C. Press, I. Symrnioudis, A.D. Watt, and J.B. Whittaker. 2002. Herbivory in global climate change research: direct effects of rising temperature on insect herbivores. *Global Change Biology* 8:1–16.
- Balvanera, P., C. Kremen, and M. Martínez-Ramos. 2005. Applying community structure analysis to ecosystem function: examples from pollination and carbon storage. *Ecological Applications* 15:360–375.
- Bangert, R.K., R.J. Turek, B. Rehill, G.M. Wimp, J.A. Schweitzer, G.J. Allan, J.K. Bailey, G.D. Martinsen, P. Keim, R.L. Lindroth, and T.G. Whitham. 2006. A genetic similarity rule determines arthropod community structure. *Molecular Ecology* 15:1379–1391.
- Banks, C.J., and E.D.M. Macaulay. 1964. The feeding, growth and reproduction of *Aphis fabae* Scop. on *Vicia faba* under experimental conditions. *Annals of Applied Biology* 53:229–242.
- Banks, C.J., and H.L. Nixon. 1958. Effects of the ant, *Lasius niger* (L.) on the feeding and excretion of the bean aphid, *Aphis fabae* Scop. *Journal of Experimental Biology* 35:703–711.
- Banks, C.J., and H.L. Nixon. 1959. The feeding and excretion rates of *Aphis fabae* Scop. on *Vicia faba* L. *Entomologia Experimentalis et Applicata* 2:77–81.
- Barbehenn, R., Q. Weir, and J.-P. Salminen. 2008. Oxidation of ingested phenolics in the tree-feeding caterpillar *Orgyia leucostigma* depends on foliar chemical composition. *Journal of Chemical Ecology* 34:748–756.
- Barbosa, P. (Ed.) 1998. *Conservation Biological Control*. Academic Press, San Diego, CA.
- Barbosa, P., and M.R. Wagner. 1989. *Introduction to Forest and Shade Tree Insects*. Academic Press, San Diego, CA.
- Barbosa, P., J. Hines, I. Kaplan, H. Martinson, A. Szczepanec, and Z. Szendrei. 2009. Associational resistance and associational susceptibility: having right or wrong neighbors. *Annual Review of Ecology, Evolution and Systematics* 40:1–20.
- Bardgett, R.D., D.K. Leemans, R. Cook, and P.J. Hobbs. 1997. Seasonality of the soil biota of grazed and ungrazed hill grasslands. *Soil Biology and Biochemistry* 29:1285–1294.
- Bardgett, R.D., D.A. Wardle, and G.W. Yeates. 1998. Linking above-ground and below-ground interactions: how plant responses to foliar herbivory influence soil organisms. *Soil Biology and Biochemistry* 30:1867–1878.
- Barker, J.S. 2008. Decomposition of Douglas-fir coarse woody debris in response to differing moisture content and initial heterotrophic colonization. *Forest Ecology and Management* 255:598–604.
- Barras, S.J. 1970. Antagonism between *Dendroctonus frontalis* and the fungus *Ceratocystis minor*. *Annals of the Entomological Society of America* 63:1187–1190.
- Barz, W., and K. Weltring. 1985. Biodegradation of aromatic extractives of wood. In *Biosynthesis and Biodegradation of Wood Components* (T. Higuchi, Ed.), pp. 607–666. Academic Press, New York, NY.
- Bascompte, J. 2009. Mutualistic networks. *Frontiers in Ecology and the Environment* 7:429–436.
- Baskerville, G.L., and P. Emin. 1969. Rapid estimation of heat accumulation from maximum and minimum temperatures. *Ecology* 50:514–522.
- Basset, Y. 1996. Local communities of arboreal herbivores in Papua New Guinea: predictors of insect variables. *Ecology* 77:1906–1919.
- Basset, Y. 2001. Communities of insect herbivores foraging on saplings versus mature trees of *Pourouma bicolor* (Cecropiaceae) in Panama. *Oecologia* 129:253–260.
- Basset, Y., B. Corbara, H. Barrios, P. Cuénoud, M. LePonce, H.-P. Aberlenc, J. Bail, D. Bito, J.R. Bridle, G. Castaño-Meneses, L. Cizek, A. Cornejo, G. Currelletti, J.H.C. Delabie, A. DeJean, R.K. Didham, M. Dufrière, L.L. Fagan, A. Floren, D.M. Frame, F. Hallé, O.J. Hardy, A. Hernandez, R.L. Kitching, T.M. Lewinsohn, O.T. Lewis, M. Manubor, E. Medianero, O. Missa, A.W. Mitchell, M. Mogia, V. Novotny, F. Ødegaard, E.G. de Oliveira, J. Orivel, C.M.P. Ozanne, O. Pascal, S. Pinzón, M. Rapp, S.P. Ribeiro, Y. Roisin, T. Roslin, D.W. Roubik, M. Samaniego, J. Schmidl, L.L. Sørensen, A. Tishechkin, C. Van Osselaer, and N.N. Winchester. 2007. IBISCA-Panama, a large-scale study of arthropod beta-diversity and vertical stratification in a lowland rainforest: rationale, study sites and field protocols. *Entomologie* 77:39–69.
- Batra, L.R. 1966. Ambrosia fungi: extent of specificity to ambrosia beetles. *Science* 153:193–195.
- Batzer, D.P., and S.A. Wissinger. 1996. Ecology of insect communities in nontidal wetlands. *Annual Review of Entomology* 41:75–100.
- Batzer, D.P., C.R. Jackson, and M. Mosner. 2000a. Influences of riparian logging on plants and invertebrates in small, depressional wetlands of Georgia, U.S.A.. *Hydrobiologia* 441:123–132.
- Batzer, D.P., C.R. Pusateri, and R. Vetter. 2000b. Impacts of fish predation on marsh invertebrates: direct and indirect effects. *Wetlands* 20:307–312.

- Baum, K.A., K.J. Haynes, F.P. Dilleuth, and J.T. Cronin. 2004. The matrix enhances the effectiveness of corridors and stepping stones. *Ecology* 85:2671–2676.
- Baumann, P., L. Baumann, C.-Y. Lai, and D. Rouh-bakhsh. 1995. Genetics, physiology, and evolutionary relationships of the genus *Buchnera*: intracellular symbionts of aphids. *Annual Review of Microbiology* 49:55–94.
- Bawa, K.S. 1990. Plant–pollinator interactions in tropical rain forests. *Annual Review of Ecology and Systematics* 21:399–422.
- Baxter, C.V., K.D. Fausch, and W.C. Saunders. 2005. Tangled webs: reciprocal flows of invertebrate prey link streams and riparian zones. *Freshwater Biology* 50:201–220.
- Baxter, C.V., K.D. Fausch, M. Murakami, and P.L. Chapman. 2007. Invading rainbow trout usurp a terrestrial prey subsidy from native charr and reduce their growth and abundance. *Oecologia* 153:461–470.
- Bayliss-Smith, T.P. 1990. The integrated analysis of seasonal energy deficits: problems and prospects. *European Journal of Clinical Nutrition* 44(supplement 1):113–121.
- Bazykin, A.D., F.S. Berezovskaya, A.S. Isaev, and R.G. Khlebopros. 1997. Dynamics of forest insect density: bifurcation approach. *Journal of Theoretical Biology* 186:267–278.
- Bazzaz, F.A. 1975. Plant species diversity in old-field successional ecosystems in southern Illinois. *Ecology* 56:485–488.
- Bazzaz, F.A. 1990. The response of natural ecosystems to the rising global CO<sub>2</sub> levels. *Annual Review of Ecology and Systematics* 21:167–196.
- Beard, K.H., A.K. Eschtruth, K.A. Vogt, D.J. Vogt, and F.N. Scatena. 2003. The effects of the frog *Eleuthrodactylus coqui* on invertebrates and ecosystem processes at two scales in the Luquillo Experimental Forest, Puerto Rico. *Journal of Tropical Ecology* 19:607–617.
- Beard, K.H., K.A. Vogt, D.J. Vogt, F.N. Scatena, A.P. Covich, R. Sigurdardottir, T.G. Siccama, and T.A. Crowl. 2005. Structural and functional responses of a subtropical forest to 10 years of hurricanes and droughts. *Ecological Monographs* 75:345–361.
- Beare, M.H., D.C. Coleman, D.A. Crossley, Jr., P.F. Hendrix, and E.P. Odum. 1995. A hierarchical approach to evaluating the significance of soil biodiversity to biogeochemical cycling. *Plant and Soil* 170:5–22.
- Beaver, L.M., B.O. Gvakharia, T.S. Vollintine, D.M. Hege, R. Stanewsky, and J.M. Giebultowicz. 2002. Loss of circadian clock function decreases reproductive fitness in males of *Drosophila melanogaster*. *Proceedings of the National Academy of Science, USA* 99:2134–2139.
- Bebi, P., D. Kilakowski, and T.T. Veblen. 2003. Interactions between fire and spruce beetles in a subalpine Rocky Mountain forest landscape. *Ecology* 84:362–371.
- Becerra, J.X. 1994. Squirt-gun defense in *Bursera* and the chrysomelid counterploy. *Ecology* 75:1991–1996.
- Becerra, J.X. 1997. Insects on plants: macroevolutionary chemical trends in host use. *Science* 276:253–256.
- Bede, J.C., R.O. Musser, G.W. Felton, and K.L. Korth. 2006. Caterpillar herbivory and salivary enzymes decrease transcript levels of *Medicago truncatula* genes encoding early enzymes in terpenoid biosynthesis. *Plant Molecular Biology* 60:519–531.
- Beedlow, P.A., D.T. Tingey, D.L. Phillips, W.E. Hogset, and D.M. Olszyk. 2004. Rising atmospheric CO<sub>2</sub> and carbon sequestration in forests. *Frontiers in Ecology and the Environment* 2:315–322.
- Begon, M., and M. Mortimer. 1981. Population Ecology: a Unified Study of Animals and Plants. Blackwell Scientific, Oxford, U.K. 200 pp.
- Behan, V.M., and S.B. Hill. 1978. Feeding habits and spore dispersal of oribatid mites in the North American Arctic. *Revue d'Ecologie et Biologie du Sol* 15:497–516.
- Behmer, S.T. 2009. Insect herbivore nutrient regulation. *Annual Review of Entomology* 54:165–187.
- Bell, G., and A. Gonzalez. 2009. Evolutionary rescue can prevent extinction following environmental change. *Ecology Letters* 12:942–948.
- Bell, W.J. 1990. Searching behavior patterns in insects. *Annual Review of Entomology* 35:447–467.
- Belle-Isle, J., and D. Kneeshaw. 2007. A stand and landscape comparison of the effects of a spruce budworm (*Choristoneura fumiferana* (Clem.)) outbreak to the combined effects of harvesting and thinning on forest structure. *Forest Ecology and Management* 246:163–174.
- Belnap, J., and D.A. Gillette. 1998. Vulnerability of desert biological soil crusts to wind erosion: the influences of crust development, soil texture, and disturbance. *Journal of Arid Environments* 39:133–142.
- Belovsky, G.E., and J.B. Slade. 2000. Insect herbivory accelerates nutrient cycling and increases plant production. *Proceedings of the National Academy of Sciences USA* 97:14412–14417.
- Belsky, A.J. 1986. Does herbivory benefit plants? A review of the evidence. *American Naturalist* 127:870–892.
- Bender, M.A., T.R. Knutson, R.E. Tuleya, J.J. Sirutis, G.A. Vecchi, S.T. Garner, and I.M. Held. 2010. Modeled impact of anthropogenic warming on the frequency of intense Atlantic hurricanes. *Science* 327:454–458.
- Benedek, S. 1988. Aquatic life. In *Lake Balaton: Research and Management* (K. Misyk, Ed., J. Pasek, translator), pp. 25–28. Hungarian Ministry of Environment and Water Management, Hungary.

- Benedict, F. 1976. Herbivory Rates and Leaf Properties in Four Forests in Puerto Rico and Florida. Ph.D. Dissertation, University of Florida, Gainesville, FL.
- Benke, A.C., and J.B. Wallace. 1997. Trophic basis of production among riverine caddisflies: implications for food web analysis. *Ecology* 78:1132–1145.
- Bennett, A., and J. Krebs. 1987. Seed dispersal by ants. *Trends in Ecology and Evolution* 2:291–292.
- Benstead, J.P., A.C. Green, L.A. Deegan, B.J. Peterson, K. Slavik, W.B. Bowden, and A.E. Hershey. 2007. Recovery of three arctic stream reaches from experimental nutrient enrichment. *Freshwater Biology* 52:1077–1089.
- Berenbaum, M.R. 1987. Charge of the light brigade: phototoxicity as a defense against insects. In *Light-activated Pesticides* (J.R. Heitz, and K.R. Downum, Eds.), pp. 206–216. American Chemical Society, Washington, DC.
- Berenbaum, M.R., and A.R. Zangerl. 1988. Stalemates in the coevolutionary arms race: syntheses, synergisms, and sundry other sins. In *Chemical Mediation of Coevolution* (K.C. Spencer, Ed.), pp. 113–132. Academic Press, Inc, San Diego, CA.
- Berenbaum, M.R., and A.R. Zangerl. 2008. Facing the future of plant–insect interaction research: le retour à la “Raison d’ tre”. *Plant Physiology* 146:804–811.
- Berlow, E.L., S.A. Navarrete, C.J. Briggs, M.E. Power, and B.A. Menge. 1999. Quantifying variation in the strengths of species interactions. *Ecology* 80:2206–2224.
- Bernays, E.A., and S. Woodhead. 1982. Plant phenols utilized as nutrients by a phytophagous insect. *Science* 216:201–203.
- Bernays, E.A., K.L. Bright, N. Gonzalez, and J. Angel. 1994. Dietary mixing in a generalist herbivore: tests of two hypotheses. *Ecology* 75:1997–2006.
- Bernhard-Reversat, F. 1982. Measuring litter decomposition in a tropical forest ecosystem: comparison of some methods. *International Journal of Ecology and Environmental Science* 8:63–71.
- Berryman, A.A. 1981. Population Systems: a General Introduction. Plenum Press, New York, NY.
- Berryman, A.A. 1996. What causes population cycles of forest Lepidoptera? *Trends in Ecology and Evolution* 11:28–32.
- Berryman, A.A. 1997. On the principles of population dynamics and theoretical models. *American Entomologist* 43:147–151.
- Berryman, A.A., N.C. Stenseth, and A.S. Isaev. 1987. Natural regulation of herbivorous forest insect populations. *Oecologia* 71:174–184.
- Bezemer, T.M., and T.H. Jones. 1998. Plant–herbivore interactions in elevated atmospheric CO<sub>2</sub>: quantitative analysis and guild effects. *Oikos* 82:212–222.
- Bezemer, T.M., T.H. Jones, and K.J. Knight. 1998. Long-term effects of elevated CO<sub>2</sub> and temperature on populations of the peach potato aphid *Myzus persicae* and its parasitoid *Aphidius matricariae*. *Oecologia* 116:128–135.
- Bezemer, T.M., G.B. De Deyn, T.M. Bossinga, N.M. van Dam, J.A. Harvey, W.H. Van der, and Putten. 2005. Soil community composition drives above-ground plant–herbivore–parasitoid interactions. *Ecology Letters* 8:652–661.
- Biesmeijer, J.C., S.P.M. Roberts, M. Reemer, R. Ohlemüller, M. Edwards, T. Peeters, A.P. Schaffers, S.G. Potts, R. Kleukers, C.D. Thomas, J. Settele, and W.E. Kunin. 2006. Parallel declines in pollinators and insect-pollinated plants in Britain and The Netherlands. *Science* 313:351–354.
- Biondini, M.E., P.W. Mielke, Jr., and K.J. Berry. 1988. Data-dependent permutation techniques for the analysis of ecological data. *Vegetatio* 75:161–168.
- Birk, E.M. 1979. Disappearance of overstorey and understorey litter in an open eucalypt forest. *Australian Journal of Ecology* 4:207–222.
- Birks, H.J.B. 1980. British trees and insects: a test of the time hypothesis over the last 13,000 years. *American Naturalist* 115:600–605.
- Bisch-Knaden, S., and R. Wehner. 2003. Local vectors in desert ants: context-dependent landmark learning during outbound and homebound runs. *Journal of Comparative Physiology A* 189:181–187.
- Bishop, J.A., and W.S. Armbruster. 1999. Thermoregulatory abilities of Alaskan bees: effects of size, phylogeny and ecology. *Functional Ecology* 13:711–724.
- Bishop, J.G. 2002. Early primary succession on Mount St. Helens: impact of insect herbivores on colonizing lupines. *Ecology* 83:191–202.
- Bjorksten, T.A., and A.A. Hoffmann. 1998. Persistence of experience effects in the parasitoid *Trichogramma* nr. *brassicae*. *Ecological Entomology* 23:110–117.
- Blanchette, R.A., and C.G. Shaw. 1978. Associations among bacteria, yeasts, and basidiomycetes during wood decay. *Phytopathology* 68:631–637.
- Blanton, C.M. 1990. Canopy arthropod sampling: a comparison of collapsible bag and fogging methods. *Journal of Agricultural Entomology* 7:41–50.
- Blatt, S.E., J.A. Janmaat, and R. Harmsen. 2001. Modelling succession to include a herbivore effect. *Ecological Modelling* 139:123–136.
- Bloesch, U. 2008. Thicket clumps: a characteristic feature of the Kagera savanna landscape, East Africa. *Journal of Vegetation Science* 19:31–44.
- Blossey, B., and T.R. Hunt-Joshi. 2003. Belowground herbivory by insects: influence on plants and above-ground herbivores. *Annual Review of Entomology* 48:521–547.
- Blum, M.S. 1980. Arthropods and ecomones: better fitness through ecological chemistry. In *Animals and Environmental Fitness* (R. Gilles, Ed.), pp. 207–222. Pergamon Press, Oxford, UK.
- Blum, M.S. 1981. Chemical Defenses of Arthropods. Academic Press, New York, NY.

- Blum, M.S. 1992. Ingested allelochemicals in insect wonderland: a menu of remarkable functions. *American Entomologist* 38:222–234.
- Blumberg, A.J.Y., P.F. Hendrix, and D.A. Crossley, Jr. 1997. Effects of nitrogen source on arthropod biomass in no-tillage and conventional tillage grain sorghum agroecosystems. *Environmental Entomology* 26:31–37.
- Blumer, P., and M. Diemer. 1996. The occurrence and consequences of grasshopper herbivory in an alpine grassland, Swiss central Alps. *Arctic and Alpine Research* 28:435–440.
- Blüthgen, N., G. Gebauer, and K. Fiedler. 2003. Disentangling a rainforest food web using stable isotopes: dietary diversity in a species-rich ant community. *Oecologia* 137:426–435.
- Boddum, T., N. Skals, M. Wirén, R. Baur, S. Rauscher, and Y. Hillbur. 2009. Optimisation of the pheromone blend of the swede midge, *Contarinia nasturii*, for monitoring. *Pest Management Science* 65:851–856.
- Boecklen, W.J. 1991. The conservation status of insects: mass extinction, scientific interest, and statutory protection. In *Entomology Serving Society: Emerging Technologies and Challenges* (S.B. Vinson, and R.L. Metcalf, Eds.), pp. 40–57. Entomological Society of America, Lanham, MD.
- Boethel, D.J., and R.D., Eikenbary (Eds.) 1986. Interactions of Plant Resistance and Parasitoids and Predators of Insects. Ellis Horwood Ltd, Chichester, UK.
- Boggs, C.L., and K.D. Freeman. 2005. Larval food limitation in butterflies: effects on adult resource allocation and fitness. *Oecologia* 144:353–361.
- Boggs, C.L., and C.L. Ross. 1993. The effect of adult food limitation on the life history traits in *Speyeria mormonia* (Lepidoptera: Nymphalidae). *Ecology* 74:433–441.
- Boman, H.G., and D. Hultmark. 1987. Cell-free immunity in insects. *Annual Review of Microbiology* 41:103–126.
- Boman, H.G., I. Faye, G.H. Gudmundsson, J.-Y. Lee, and D.-A. Lidholm. 1991. Cell-free immunity in cecropia: a model system for antibacterial proteins. *European Journal of Biochemistry* 201:23–31.
- Bonada, N., N. Prat, V.H. Resh, and B. Statzner. 2006. Developments in aquatic insect biomonitoring: a comparative analysis of recent approaches. *Annual Review of Entomology* 51:495–523.
- Bond, W.J. 1993. Keystone species. In *Biodiversity and Ecosystem Function* (E.D. Schulze, and H.A. Mooney, Eds.), pp. 237–253. Springer-Verlag, Berlin, Germany.
- Bongiovanni, R., and J. Lowenberg-Deboer. 2004. Precision agriculture and sustainability. *Precision Agriculture* 5:359–387.
- Boorman, S.A., and P.R. Levitt. 1972. Group selection on the boundary of a stable population. *Proceedings of the National Academy of Sciences, USA* 69:2711–2713.
- Boring, L.R., W.T. Swank, and C.D. Monk. 1988. Dynamics of early successional forest structure and processes in the Coweeta Basin. In *Forest Hydrology and Ecology at Coweeta* (W.T. Swank, and D.A. Crossley Jr., Eds.), pp. 161–179. Springer-Verlag, New York, NY.
- Bormann, F.H., and G.E. Likens. 1979. Pattern and Process in a Forested Ecosystem. Springer-Verlag, New York, NY.
- Bos, M.M., D. Veddeler, A.K. Bogdanski, A.-M. Klein, T. Tschardtke, I. Steffan-Dewenter, and J.M. Tylianakis. 2007. Caveats to quantifying ecosystem services: fruit abortion blurs benefits from crop pollination. *Ecological Applications* 17:1841–1849.
- Bossart, J.L., E. Opuni-Frimpong, S. Kuudaar, and E. Nkrumah. 2006. Richness, abundance and complementarity of fruit-feeding butterfly species in relict sacred forests and forest reserves of Ghana. *Biodiversity and Conservation* 15:33–359.
- Bostock, R.M., R. Karban, J.S. Thaler, P.D. Weyman, and D. Gilchrist. 2001. Signal interactions in induced resistance to pathogens and insect herbivores. *European Journal of Plant Pathology* 107:103–111.
- Botkin, D.B. 1981. Causality and succession. In *Forest Succession: Concepts and Application* (D.C. West, H.H. Shugart, and D.B. Botkin, Eds.), pp. 36–55. Springer-Verlag, New York.
- Boucot, A.J. 1990. Evolutionary Paleobiology of Behavior and Coevolution. Elsevier, Amsterdam, The Netherlands.
- Boucot, A.J., and G.O. Poinar, Jr. 2010. Fossil Behavior Compendium. Taylor and Francis Group LLC, Boca Raton, FL.
- Boulton, A.J., C.G. Peterson, N.B. Grimm, and S.G. Fisher. 1992. Stability of an aquatic macroinvertebrate community in a multiyear hydrologic disturbance regime. *Ecology* 73:2192–2207.
- Bowers, M.D., and G.M. Puttick. 1988. Response of generalist and specialist insects to qualitative allelochemical variation. *Journal of Chemical Ecology* 14:319–334.
- Boyce, M.S. 1984. Restitution of r- and K-selection as a model of density-dependent natural selection. *Annual Review of Ecology and Systematics* 15:427–447.
- Boyd, R.S. 2002. Does elevated body Ni concentration protect insects against pathogens? A test using *Melanotrichus boydi* (Heteroptera: Miridae). *American Midland Naturalist* 147:225–236.
- Boyd, R.S. 2004. Ecology of metal hyperaccumulation. *New Phytologist* 162:563–567.
- Boyd, R.S. 2007. The defense hypothesis of elemental hyperaccumulation: status, challenges and new directions. *Plant and Soil* 293:153–176.
- Boyd, R.S. 2009. High-nickel insects and nickel hyperaccumulator plants: a review. *Insect Science* 16:19–31.
- Boyd, R.S., and S.N. Martens. 1994. Nickel hyperaccumulated by *Thlaspi montanum* var. *montanum* is

- acutely toxic to an insect herbivore. *Oikos* 70:21–25.
- Boyd, R.S., and W.J. Moar. 1999. The defensive function of Ni in plants: response of the polyphagous herbivore *Spodoptera exigua* (Lepidoptera: Noctuidae) to hyperaccumulator and accumulator species of *Streptanthus* (Brassicaceae). *Oecologia* 118:218–224.
- Boyd, R.S., and M.A. Wall. 2001. Responses of generalist predators fed high-Ni *Melanotrichus boydi* (Heteroptera: Miridae): elemental defense against the third trophic level. *American Midland Naturalist* 146:186–198.
- Bozer, S.F., M.S. Traugott, and N.E. Stamp. 1996. Combined effects of allelochemical-fed and scarce prey of the generalist insect predator *Podisus maculiventris*. *Ecological Entomology* 21:328–334.
- Bradbeer, N. 2009. Bees and Their Role in Forest Livelihoods: a Guide to the Services Provided by Bees and the Sustainable Harvesting, Processing and Marketing of Their Products. FAO, Rome, Italy.
- Bradley, C.A., and S. Altizer. 2005. Parasites hinder monarch butterfly flight: implications for disease spread in migratory hosts. *Ecology Letters* 8:290–300.
- Bradshaw, J.W.S., and P.E. Howse. 1984. Sociochemicals of ants. In *Chemical Ecology of Insects* (W.J. Bell, and R.T. Cardé, Eds.), pp. 429–473. Chapman and Hall, London, UK.
- Bradshaw, W.E., and C.M. Holzapfel. 2001. Genetic shift in photoperiodic response correlated with global warming. *Proceedings of the National Academy of Sciences, USA* 98:14509–14511.
- Braithwaite, R.W., and J.A. Estbergs. 1985. Fire patterns and woody litter vegetation trends in the Alligator Rivers region of northern Australia. In *Ecology and Management of the World's Savannas* (J.C. Tothill, and J.J. Mott, Eds.), pp. 359–364. Australian Academy of Science, Canberra, Australia.
- Braschler, B., L. Marini, G.H. Thommen, and B. Baur. 2009. Effects of small-scale grassland fragmentation and frequent mowing on population density and species diversity of orthopterans: a long-term study. *Ecological Entomology* 34:321–329.
- Brauman, A., M.D. Kane, M. Labat, and J.A. Breznak. 1992. Genesis of acetate and methane by gut bacteria of nutritionally diverse termites. *Science* 257:1384–1387.
- Bray, D.P., K.K. Brandi, R.P. Brazil, A.G. Oliveira, and J.G.C. Hamilton. 2009. Synthetic sex pheromone attracts the Leishmaniasis vector *Lutzomyia longipalpis* (Diptera: Psychodidae) to traps in the field. *Journal of Medical Entomology* 46:428–434.
- Bray, R.S. 1996. *Armies of Pestilence: the Impact of Disease on History*. Barnes and Noble, New York, NY.
- Brazzel, J.R., and L.D. Newsom. 1959. Diapause in *Anthomomus grandis* Boh. *Journal of Economic Entomology* 52:603–611.
- Bredenhand, E., and M.J. Samways. 2009. Impact of a dam on benthic macroinvertebrates in a small river in a biodiversity hotspot: Cape Floristic Region, South Africa. *Journal of Insect Conservation* 13:297–307.
- Brenes-Arguedas, T., P.D. Coley, and T.A. Kursar. 2008. Divergence and diversity in the defensive ecology of *Inga* at two Neotropical sites. *Journal of Ecology* 96:127–135.
- Brenner, A.G.F., and J.F. Silva. 1995. Leaf-cutting ants and forest groves in a tropical parkland savanna of Venezuela: facilitated succession? *Journal of Tropical Ecology* 11:651–669.
- Breshears, D.D., N.S. Cobb, P.M. Rich, K.P. Price, C.D. Allen, R.G. Balice, W.H. Romme, J.H. Kastens, M.L. Floyd, J. Belnap, J.J. Anderson, O.B. Meyers, and C.W. Meyer. 2005. Regional vegetation die-off in response to global-change-type drought. *Proceedings of the National Academy of Sciences USA* 102:15144–15148.
- Brey, P.T., W.-J. Lee, M. Yamakawa, Y. Koizumi, S. Perrot, M. François, and M. Ashida. 1993. Role of the interument in insect immunity: epicuticular abrasion and induction of cecropin synthesis in cuticular epithelial cells. *Proceedings of the National Academy of Sciences, USA* 90:6275–6279.
- Breznak, J.A., and A. Brune. 1994. Role of microorganisms in the digestion of lignocellulose by termites. *Annual Review of Entomology* 39:453–487.
- Briand, F., and J.E. Cohen. 1984. Community food webs have scale-invariant structure. *Nature* 307:264–267.
- Bridges, J.R. 1983. Mycangial fungi of *Dendroctonus frontalis* (Coleoptera: Scolytidae) and their relationship to beetle population trends. *Environmental Entomology* 12:858–861.
- Bridges, J.R., and J.C. Moser. 1983. Role of two phoretic mites in transmission of bluestain fungus, *Ceratocystis minor*. *Ecological Entomology* 8:9–12.
- Bridges, J.R., and J.C. Moser. 1986. Relationship of phoretic mites (Acari: Tarsonemidae) to the bluestaining fungus, *Ceratocystis minor*, in trees infested by southern pine beetle (Coleoptera: Scolytidae). *Environmental Entomology* 15:951–953.
- Bridges, J.R., and T.J. Perry. 1985. Effects of mycangial fungi on gallery construction and distribution of bluestain in southern pine beetle-infested pine bolts. *Journal of Entomological Science* 20:271–275.
- Bridges, J.R., W.A. Nettleton, and M.D. Connor. 1985. Southern pine beetle (Coleoptera: Scolytidae) infestations without the bluestain fungus, *Ceratocystis minor*. *Journal of Economic Entomology* 78:325–327.
- Bristow, C.M. 1991. Why are so few aphids ant-tended? In *Ant-plant Interactions* (C.R. Huxley, and D.F. Cutler, Eds.), pp. 104–119. Oxford University Press, Oxford, UK.
- Broadway, R.M. 1995. Are insects resistant to plant-proteinase inhibitors? *Journal of Insect Physiology* 41:107–116.

- Broadway, R.M. 1997. Dietary regulation of serine proteinases that are resistant to serin proteinase inhibitors. *Journal of Insect Physiology* 43:855–874.
- Broderick, N.A., K.F. Raffa, R.M. Goodman, and J. Handelsman. 2004. Census of the bacterial community of the gypsy moth larval midgut by using culturing and culture-independent methods. *Applied and Environmental Microbiology* 70:293–300.
- Brody, A.K., T.M. Palmer, K. Fox-Dobbs, and D.F. Doak. 2010. Termites, vertebrate herbivores, and the fruiting success of *Acacia drepanolobium*. *Ecology* 91:399–407.
- Brokaw, N.V.L. 1985. Treefalls, regrowth, and community structure in tropical forests. In *The Ecology of Natural Disturbance and Patch Dynamics* (S.T.A. Pickett, and P.S. White, Eds.), pp. 53–69. Academic Press, Orlando, FL.
- Bronstein, J.L. 1998. The contribution of ant–plant protection studies to our understanding of mutualism. *Biotropica* 30:150–161.
- Brookes, M.H., R.W. Stark, and R.W. Campbell (Eds.) 1978. *The Douglas-fir Tussock Moth: a Synthesis*. USDA Forest Service Tech. Bull 1585, USDA Washington, DC.
- Brosi, B.J., G.C. Daily, C.P. Chamberlain, and M. Mills. 2009. Detecting changes in habitat-scale bee foraging in tropical fragmented landscape using stable isotopes. *Forest Ecology and Management* 258:1846–1855.
- Brower, A.V.Z. 1996. Parallel race formation and the evolution of mimicry in *Heliconius* butterflies: a phylogenetic hypothesis from mitochondrial DNA sequences. *Evolution* 50:195–221.
- Brower, L.P., J.V.Z. Brower, and F.P. Cranston. 1965. Courtship behavior of the queen butterfly, *Danaus gilippus berenice* (Cramer). *Zoologica* 50:1–39.
- Brower, L.P., W.N. Ryerson, L.L. Coppinger, and S.C. Glazier. 1968. Ecological chemistry and the palatability spectrum. *Science* 161:1349–1351.
- Brown, B.J., and T.F.H. Allen. 1989. The importance of scale in evaluating herbivory impacts. *Oikos* 54:189–194.
- Brown, B.J., and J.J. Ewel. 1987. Herbivory in complex and simple tropical successional ecosystems. *Ecology* 68:108–116.
- Brown, J.H., O.J. Reichman, and D.W. Davidson. 1979. Granivory in desert ecosystems. *Annual Review of Ecology and Systematics* 10:201–227.
- Brown, J.H., T.G. Whitham, S.K.M. Ernest, and C.A. Gehring. 2001. Complex species interactions and the dynamics of ecological systems: long-term experiments. *Science* 293:643–650.
- Brown, J.H., J.F. Gillooly, A.P. Allen, V.M. Savage, and G.B. West. 2004. Toward a metabolic theory of ecology. *Ecology* 85:1771–1789.
- Brown, M., T.A. Black, Z. Nestic, V.N. Foord, D.L. Spittlehouse, A.L. Fredeen, N.J. Grant, P.J. Burton, and J.A. Trofymow. 2010. Impact of mountain pine beetle on the net ecosystem production of lodgepole pine stands in British Columbia. *Agricultural and Forest Meteorology* 150:254–264.
- Brown, M.V., T.E. Nebeker, and C.R. Honea. 1987. Thinning increases loblolly pine vigor and resistance to bark beetles. *Southern Journal of Applied Forestry* 11:28–31.
- Brown, S., and A.E. Lugo. 1982. Storage and production of organic matter in tropical forests and their role in the global carbon cycle. *Biotropica* 14:161–187.
- Brown, S.C., K. Smith, and D. Batzer. 1997. Macroinvertebrate responses to wetland restoration in northern New York. *Environmental Entomology* 26:1016–1024.
- Brown, V.C. 1995. Insect herbivores and gaseous air pollutants—current knowledge and predictions. In *Insects in a Changing Environment* (R. Harrington, and N.E. Stork, Eds.), pp. 219–249. Academic Press, London, UK.
- Brown, V.K. 1984. Secondary succession: insect–plant relationships. *BioScience* 34:710–716.
- Brown, V.K. 1986. Life cycle strategies and plant succession. In *The Evolution of Insect Life Cycles* (F. Taylor, and R. Karban, Eds.), pp. 105–124. Springer-Verlag, New York, NY.
- Brown, V.K., and A.C. Gange. 1989. Differential effects of above- and below-ground insect herbivory during early plant succession. *Oikos* 54:67–76.
- Brown, V.K., and A.C. Gange. 1991. Effects of root herbivory on vegetation dynamics. In *Plant Root Growth: an Ecological Perspective* (D. Atkinson, Ed.), pp. 453–470. Blackwell Scientific, Oxford, UK.
- Brown, V.K., and P.S. Hyman. 1986. Successional communities of plants and phytophagous Coleoptera. *Journal of Ecology* 74:963–975.
- Brown, V.K., and T.R.E. Southwood. 1983. Trophic diversity, niche breadth and generation times of exopterygote insects in a secondary succession. *Oecologia* 56:220–225.
- Brown, V.K., A.C. Gange, I.M. Evans, and A.L. Storr. 1987. The effect of insect herbivory on the growth and reproduction of two annual *Vicia* species at different stages in plant succession. *Journal of Ecology* 75:1173–1189.
- Brown, V.K., M. Jepson, and C.W.D. Gibson. 1988. Insect herbivory: effects on early old field succession demonstrated by chemical exclusion methods. *Oikos* 52:293–302.
- Bruinsma, M., and M. Dicke. 2008. Herbivore-induced indirect defense: from induction mechanisms to community ecology. In *Induced Plant Resistance to Herbivory* (A. Schaller, Ed.), pp. 31–60. Springer, Dordrecht, The Netherlands.
- Brys, R., H. Jacquemyn, and M. Hermy. 2008. Pollination efficiency and reproductive patterns in relation to local plant density, population size, and floral display

- in the rewarding *Listera ovata* (Orchidaceae). *Botanical Journal of the Linnean Society* 157:713–721.
- Buddle, C.M., D.W. Langor, G.R. Pohl, and J.R. Spence. 2006. Arthropod responses to harvesting and wildfire: implications for emulation of natural disturbance in forest management. *Biological Conservation* 128:346–357.
- Buhl, J., D.J.T. Sumpter, I.D. Couzin, J.J. Hale, E. Despland, E.R. Miller, and S.J. Simpson. 2006. From disorder to order in marching locusts. *Science* 312:1402–1406.
- Bullock, S.H. 1991. Herbivory and the demography of the chaparral shrub *Ceanothus greggii* (Rhamnaceae). *Madroño* 38:63–72.
- Burd, M., and J.J. Howard. 2005. Central-place foraging continues beyond the nest entrance; the underground performance of leaf-cutting ants. *Animal Behaviour* 70:737–744.
- Burdon, F.J., and J.S. Harding. 2008. The linkage between riparian predators and aquatic insects across a stream-resource spectrum. *Freshwater Biology* 53:330–346.
- Burger, J.M.S., M. Kolss, J. Pont, and T.J. Kawecki. 2008. Learning ability and longevity: a symmetrical evolutionary trade-off in *Drosophila*. *Evolution* 62:1294–1304.
- Burkle, L., and R. Irwin. 2009. The importance of inter-annual variation and bottom-up nitrogen enrichment for plant-pollinator networks. *Oikos* 118:1816–1829.
- Burkle, L., and R. Irwin. 2010. Beyond biomass: measuring the effects of community-level nitrogen enrichment on floral traits, pollinator visitation and plant reproduction. *Journal of Ecology* 98:705–717.
- Burney, D.A., and T.F. Flannery. 2005. Fifty millennia of catastrophic extinctions after human contact. *Trends in Ecology and Evolution* 20:395–401.
- Burt, A. 2003. Site-specific selfish genes as tools for the control and genetic engineering of natural populations. *Proceedings of the Royal Society B* 270:921–928.
- Buteler, M., D.K. Weaver, and R.K.D. Peterson. 2009. Oviposition behavior of the wheat stem sawfly when encountering plants infested with cryptic conspecifics. *Environmental Entomology* 38:1707–1715.
- Butler, C.D., and J.T. Trumble. 2008. Effects of pollutants on bottom-up and top-down processes in insect-plant interactions. *Environmental Pollution* 156:1–10.
- Butler, C.D., N.E. Beckage, and J.T. Trumble. 2009. Effects of terrestrial pollutants on insect parasitoids. *Environmental Toxicology and Chemistry* 28:1111–1119.
- Byers, J.A., and D.L. Wood. 1981. Antibiotic-induced inhibition of pheromone synthesis in a bark beetle. *Science* 213:763–764.
- Byrd, J.H., and J.L., Castner (Eds.) 2001. The Utility of Arthropods in Legal Investigations. CRC Press, Boca Raton, FL.
- Calder, I.R. 2001. Canopy processes: implications for transpiration, interception and splash induced erosion, ultimately for forest management and water resources. *Plant Ecology* 153:203–214.
- Callaway, R.M., R.H. DeLuca, and W.M. Belliveau. 1999. Biological-control herbivores may increase competitive ability of the noxious weed *Centaurea maculosa*. *Ecology* 80:1196–1201.
- Cambeport, Y. 1991. From saprophagy to coprophagy. In *Dung Beetle Ecology* (I. Hanski, and Y. Cambeport, Eds.), pp. 22–35. Princeton University Press, Princeton, NJ.
- Camilo, G.R., and M.R. Willig. 1995. Dynamics of a food chain model from an arthropod-dominated lotic community. *Ecological Modelling* 79:121–129.
- Campbell, B.C., and P.J. Shea. 1990. A simple staining technique for assessing feeding damage by *Leptoglossus occidentalis* Heidemann (Hemiptera: Coreidae) on cones. *Canadian Entomologist* 122:963–968.
- Canham, C.D., J. Thompson, J.K. Zimmerman, and M. Uriarte. 2010. Variation in susceptibility to hurricane damage as a function of storm intensity in Puerto Rican tree species. *Biotropica* 42:87–94.
- Capinera, J.L. 1987. Population ecology of rangeland grasshoppers. In *Integrated Pest Management on Rangeland: a Shortgrass Prairie Perspective* (J.L. Capinera, Ed.), pp. 162–182. Westview Press, Boulder, CO.
- Cappuccino, N. 1992. The nature of population stability in *Eurosta solidaginis*, a nonoutbreeding herbivore of goldenrod. *Ecology* 73:1792–1801.
- Cárcamo, H.A., T.A. Abe, C.E. Prescott, F.B. Holl, and C.P. Chanway. 2000. Influence of millipedes on litter decomposition, N mineralization, and microbial communities in a coastal forest in British Columbia, Canada. *Canadian Journal of Forest Research* 30:817–826.
- Cardé, R.T. 1996. Odour plumes and odour-mediated flight in insects. In *Olfaction in Mosquito-host Interactions*. *Ciba Foundation Symposium 200* pp. 54–70. John Wiley & Sons, Chichester, UK.
- Cardé, R.T., and T.C. Baker. 1984. Sexual communication with pheromones. In *Chemical Ecology of Insects* (W.J. Bell, and R.T. Cardé, Eds.), pp. 355–383. Chapman and Hall, London, UK.
- Cardinale, B.J., M.A. Palmer, and S.L. Collins. 2002. Species diversity enhances ecosystem functioning through interspecific facilitation. *Nature* 415:426–429.
- Cardinale, B.J., J.J. Weis, A.E. Forbes, K.J. Tilmon, and A.R. Ives. 2006. Biodiversity as both a cause and consequence of resource availability: a study of reciprocal causality in a predator-prey system. *Journal of Animal Ecology* 75:497–505.
- Carlson, J.C., L.A. Dyer, F.X. Omlin, and J.C. Beier. 2009. Diversity cascades and malaria vectors. *Journal of Medical Entomology* 46:460–464.

- Carlton, R.G., and C.R. Goldman. 1984. Effects of a massive swarm of ants on ammonium concentrations in a subalpine lake. *Hydrobiologia* 111:113–117.
- Carpenter, D., and N. Cappuccino. 2005. Herbivory, time since introduction and invasiveness of exotic plants. *Journal of Ecology* 93:315–321.
- Carpenter, S.R., and J.F. Kitchell. 1984. Plankton community structure and limnetic primary production. *American Naturalist* 124:159–172.
- Carpenter, S.R., and J.F. Kitchell. 1987. The temporal scale of variance in lake productivity. *American Naturalist* 129:417–433.
- Carpenter, S.R., and J.F. Kitchell. 1988. Consumer control of lake productivity. *BioScience* 38:764–769.
- Carpenter, S.R., J.F. Kitchell, and J.R. Hodgson. 1985. Cascading trophic interactions and lake productivity. *BioScience* 35:634–639.
- Carrière, Y., S. Masaki, and D.A. Roff. 1997. The coadaptation of female morphology and offspring size: a comparative analysis in crickets. *Oecologia* 110:197–204.
- Carrière, Y., T.J. Dennehy, B. Pedersen, S. Haller, C. Ellers-Kirk, L. Antilla, Y.-B. Liu, E. Willott, and B.E. Tabashnik. 2001a. Large-scale management of insect resistance to transgenic cotton in Arizona: can transgenic insecticidal crops be sustained?. *Journal of Economic Entomology* 94:315–325.
- Carrière, Y., C. Ellers-Kirk, A.L. Patin, M.A. Sims, S. Meyer, Y.-B. Liu, T.J. Dennehy, and B.E. Tabashnik. 2001b. Overwintering cost associated with resistance to transgenic cotton in the pink bollworm (Lepidoptera: Gelechiidae). *Journal of Economic Entomology* 94:935–941.
- Carrière, Y., C. Ellers-Kirk, M. Sisterson, L. Antilla, M. Whitlow, T.J. Dennehy, and B.E. Tabashnik. 2003. Long-term regional suppression of pink bollworm by *Bacillus thuringiensis* cotton. *Proceedings of the National Academy of Sciences, USA* 100:1519–1523.
- Carroll, C.R., and C.A. Hoffman. 1980. Chemical feeding deterrent mobilized in response to insect herbivory and counter adaptation by *Epilachna turedimnotata*. *Science* 209:414–416.
- Carroll, G. 1988. Fungal endophytes in stems and leaves: from latent pathogen to mutualistic symbiont. *Ecology* 69:2–9.
- Carson, R. 1962. Silent Spring. Houghton-Mifflin, New York, NY.
- Carson, W.P., and R.B. Root. 2000. Herbivory and plant species coexistence: community regulation by an outbreaking phytophagous insect. *Ecological Monographs* 70:73–99.
- Carter, G.A., and A.K. Knapp. 2001. Leaf optical properties in higher plants: linking spectral characteristics to stress and chlorophyll concentration. *American Journal of Botany* 88:677–684.
- Carter, J.L., S.V. Fend, and S.S. Kennelly. 1996. The relationships among three habitat scales and stream benthic invertebrate community structure. *Freshwater Biology* 35:109–124.
- Cartron, J.-L.E., M.C. Molles, Jr., J.F. Schuetz, C.S. Crawford, and C.N. Dahm. 2003. Ground arthropods as potential indicators of flooding regime in the riparian forest of the middle Rio Grande, New Mexico. *Environmental Entomology* 32:1075–1084.
- Casey, T.M. 1988. Thermoregulation and heat exchange. *Advances in Insect Physiology* 20:119–146.
- Cates, R.G. 1980. Feeding patterns of monophagous, oligophagous, and polyphagous insect herbivores: the effect of resource abundance and plant chemistry. *Oecologia* 46:22–31.
- Cattaneo, M.G., C. Yafuso, C. Schmidt, C.-Y. Huang, M. Rahman, C. Olson, C. Ellers-Kirk, B.J. Orr, S.E. Marsh, L. Antilla, P. Dutilleul, and Y. Carrière. 2006. Farm-scale evaluation of the impacts of transgenic cotton on biodiversity, pesticide use, and yield. *Proceedings of the National Academy of Sciences, USA* 103:7571–7576.
- Cattânio, J.H., E.A. Davidson, D.C. Nepstad, L.V. Verchot, and I.L. Ackerman. 2002. Unexpected results of a pilot throughfall exclusion experiment on soil emissions of CO<sub>2</sub>, CH<sub>4</sub>, N<sub>2</sub>O and NO in eastern Amazonia. *Biology and Fertility of Soils* 36:102–108.
- Cavaliere, L.F., and H. Koçak. 1994. Chaos in biological control systems. *Journal of Theoretical Biology* 169:179–187.
- Cavaliere, L.F., and H. Koçak. 1995a. Intermittent transition between order and chaos in an insect pest population. *Journal of Theoretical Biology* 175:231–234.
- Cavaliere, L.F., and H. Koçak. 1995b. Chaos: a potential problem in the biological control of insect pests. *Mathematical Biosciences* 127:1–17.
- Cebrián, J., and C.M. Duarte. 1994. The dependence of herbivory on growth rate in natural plant communities. *Functional Ecology* 8:518–525.
- Céréghino, R., C. Leroy, A. Dejean, and B. Corbara. 2010. Ants mediate the structure of phytotelm communities in an ant-garden bromeliad. *Ecology* 91:1549–1556.
- Cerritos, R., and Z. Cano-Santana. 2008. Harvesting grasshoppers *Sphenarium purpurascens* in Mexico for human consumption: a comparison with insecticidal control for managing pest outbreaks. *Crop Protection* 27:473–480.
- Chabot, B.F., and D.J. Hicks. 1982. The ecology of leaf life spans. *Annual Review of Ecology and Systematics* 13:229–259.
- Chalk, R., H. Townson, and P.J. Ham. 1995. *Brugia pahangi*: the effects of cecropins on microfilariae *in vitro* and in *Aedes aegypti*. *Experimental Parasitology* 80:401–406.
- Chamberlain, K., E. Guerrieri, F. Pennacchio, J. Pettersson, J.A. Pickett, G.M. Poppy, W. Powell, L.J. Wadhams, and C.M. Woodcock. 2001. Can aphid-



- induced plant signals be transmitted aurally and through the rhizosphere? *Biochemical Systematics and Ecology* 29:1063–1074.
- Chambers, J.Q., G.P. Asner, D.C. Morton, L.O. Anderson, S.S. Saatchi, F.D.B. Espirito-Santo, M. Palace, and C. Souza, Jr. 2007. Regional ecosystem structure and function: ecological insights from remote sensing of tropical forests. *Trends in Ecology and Evolution* 22:414–423.
- Changnon, S.A., R.T. Shealy, and R.W. Scott. 1991. Precipitation changes in fall, winter, and spring caused by St. Louis. *Journal of Applied Meteorology* 30:126–134.
- Chapin, III, F.S., A.J. Bloom, C.B. Field, and R.H. Waring. 1987. Plant responses to multiple environmental factors. *BioScience* 37:49–57.
- Chapman, C.A., and L.J. Chapman. 1996. Frugivory and the fate of dispersed and non-dispersed seeds of six African tree species. *Journal of Tropical Ecology* 12:491–504.
- Chapman, L.J., K.R. Schneider, C. Apodaca, and C.A. Chapman. 2004. Respiratory ecology of macroinvertebrates in a swamp-river system of East Africa. *Biotropica* 36:572–585.
- Chapman, R.F. 1982. *The Insects: Structure and Function*, 3<sup>rd</sup> ed. Harvard University Press, Cambridge, MA.
- Chapman, R.F. 2003. Contact chemoreception in feeding by phytophagous insects. *Annual Review of Entomology* 48:455–484.
- Chapman, S.K., S.C. Hart, N.S. Cobb, T.G. Whitham, and G.W. Koch. 2003. Insect herbivory increases litter quality and decomposition: an extension of the acceleration hypothesis. *Ecology* 84:2867–2876.
- Chapman, S.K., J.A. Schweitzer, and T.G. Whitham. 2006. Herbivory differentially alters plant litter dynamics of evergreen and deciduous trees. *Oikos* 114:566–574.
- Chase, J.M. 1996. Abiotic controls of trophic cascades in a simple grassland food chain. *Oikos* 77:495–506.
- Chase, J.M. 2007. Drought mediates the importance of stochastic community assembly. *Proceedings of the National Academy of Sciences, USA* 104:17430–17434.
- Chase, J.M., M.A. Leibold, A.L. Downing, and J.B. Shurin. 2000. The effects of productivity, herbivory, and plant species turnover in grassland food webs. *Ecology* 81:2485–2497.
- Chase, T.N., R.A. Pielke, T.G.F. Kittel, R. Nemani, and S.W. Running. 1996. Sensitivity of a general circulation model to global changes in leaf area index. *Journal of Geophysical Research* 101:7393–7408.
- Chazdon, R., and N. Fetcher. 1984. Photosynthetic light environments in a lowland tropical rainforest in Costa Rica. *Journal of Ecology* 72:553–564.
- Chen, J., J.F. Franklin, and T.A. Spies. 1995. Growing-season microclimatic gradients from clearcut edges into old-growth Douglas-fir forests. *Ecological Applications* 5:74–86.
- Chen, J., G. Henderson, and R.A. Laine. 1988. Isolation and identification of 2-phenoxyethanol from a ballpoint pen ink as a trail-following substance of *Coptotermes formosanus* Shiraki and *Reticulitermes* sp. *Journal of Entomological Science* 33:97–105.
- Chen, J., G. Henderson, C.C. Grimm, S.W. Lloyd, and R.A. Laine. 1998. Termites fumigate their nests with naphthalene. *Nature* 392:558–559.
- Chen, Y., K.L. Giles, M.E. Payton, and M.H. Greenstone. 2000. Identifying key cereal aphid predators by molecular gut analysis. *Molecular Ecology* 9:1887–1898.
- Chilcutt, C.F., and B.E. Tabashnik. 1997. Host-mediated competition between the pathogen *Bacillus thuringiensis* and the parasitoid *Cotesia plutellae* of the diamondback moth (Lepidoptera: Plutellidae). *Environmental Entomology* 26:38–45.
- Chilcutt, C.F., and B.E. Tabashnik. 2004. Contamination of refuges by *Bacillus thuringiensis* toxin genes from transgenic maize. *Proceedings of the National Academy of Sciences, USA* 101:7526–7529.
- Chittka, L., and R. Menzel. 1992. The evolutionary adaptation of flower colours and the insect pollinators' colour vision. *Journal of Comparative Physiology A* 171:171–181.
- Chittka, L., and N.E. Raine. 2006. Recognition of flowers by pollinators. *Current Opinion in Plant Biology* 9:428–435.
- Chittka, L., A. Gumbert, and J. Kunze. 1997. Foraging dynamics of bumble bees: correlates of movements within and between plant species. *Behavioral Ecology* 8:239–249.
- Christensen, K.M., and T.G. Whitham. 1991. Indirect herbivore mediation of avian seed dispersal in pinon pine. *Ecology* 72:534–542.
- Christensen, Jr., N.L., S.V. Gregory, P.R. Hagenstein, T.A. Heberlein, J.C. Hendee, J.T. Olson, J.M. Peek, D.A. Perry, T.D. Schowalter, K. Sullivan, G.D. Tilman, and K.A. Vogt. 2000. *Environmental Issues in Pacific Northwest Forest Management*. National Academy Press, Washington, D.C..
- Christenson, L.M., G.M. Lovett, M.J. Mitchell, and P.M. Groffman. 2002. The fate of nitrogen in gypsy moth frass deposited to an oak forest floor. *Oecologia* 131:444–452.
- Cipollini, Jr., D.F. 1997. Wind-induced mechanical stimulation increases pest resistance in common bean. *Oecologia* 111:84–90.
- Clark, D.B., and D.A. Clark. 1985. Seedling dynamics of a tropical tree: impacts of herbivory and mistletoe damage. *Ecology* 66:1884–1892.
- Clark, J.S., C. Fastie, and G. Hurr. 1998. Reid's paradox of rapid plant migration: dispersal theory and interpretation of paleoecological records. *BioScience* 48:13–24.
- Clark, K.L., N. Skowronski, and J. Hom. 2010. Invasive insects impact forest carbon dynamics. *Global Change Biology* 16:88–101.

- Clark, L.R., P.W. Geier, R.D. Hughes, and R.F. Morris. 1967. *The Ecology of Insect Populations in Theory and Practice*. Methuen, London, UK.
- Clark, W.C. 1979. Spatial structure relationship in a forest insect system: simulation models and analysis. *Mitteilungen der Schweizerischen Entomologischen Gesellschaft* 52:235–257.
- Clarke, C.M., and R.L. Kitching. 1995. Swimming ants and pitcher plants: a unique ant–plant interaction from Borneo. *Journal of Tropical Ecology* 11:589–602.
- Classen, A.T., S.C. Hart, T.G. Whitham, N.S. Cobb, and G.W. Koch. 2005. Insect infestations linked to changes in microclimate: important climate change implications. *Soil Science Society of America Journal* 69:2049–2057.
- Classen, A.T., S.K. Chapman, T.G. Whitham, S.C. Hart, and G.W. Koch. 2007a. Genetic-based plant resistance and susceptibility traits to herbivory influence needle and root litter nutrient dynamics. *Journal of Ecology* 95:1181–1194.
- Classen, A.T., S.T. Overby, S.C. Hart, G.W. Koch, and T.G. Whitham. 2007b. Season mediates herbivore effects on litter and soil microbial abundance and activity in a semi-arid woodland. *Plant and Soil* 295:217–227.
- Claudianos, C., H. Ranson, R.M. Johnson, S. Biswas, M.A. Schuler, M.R. Berenbaum, R. Feyereisen, and J.G. Oakeshott. 2006. A deficit of detoxification enzymes: pesticide sensitivity and environmental response in the honey bee. *Insect Molecular Biology* 15:615–636.
- Clausen, L.W. 1954. *Insect Fact and Folklore*. MacMillan Co, New York, NY.
- Clay, K. 1990. Fungal endophytes of grasses. *Annual Review of Ecology and Systematics* 21:275–297.
- Clay, K., T.N. Hardy, and A.M. Hammond. 1985. Fungal endophytes of grasses and their effects on an insect herbivore. *Oecologia* 66:1–5.
- Clay, K., S. Marks, and G.P. Cheplick. 1993. Effects of insect herbivory and fungal endophyte infection on competitive interactions among grasses. *Ecology* 74:1767–1777.
- Cleary, D.F.R., and A. Grill. 2004. Butterfly response to severe ENSO-induced forest fires in Borneo. *Ecological Entomology* 29:666–676.
- Clements, F.E. 1916. *Plant Succession: an Analysis of the Development of Vegetation*. Carnegie Institute of Washington Publication 242, Washington, D.C.
- Cloe, III, W.W., and G.C. Garman. 1996. The energetic importance of terrestrial arthropod inputs to three warm-water streams. *Freshwater Biology* 36:105–114.
- Cobb, R.C., D.A. Orwig, and S. Currie. 2006. Decomposition of green foliage in eastern hemlock forests of southern New England impacted by hemlock woolly adelgid infestations. *Canadian Journal of Forest Research* 36:1331–1341.
- Cociancich, S., P. Bulet, C. Hetru, and J.A. Hoffmann. 1994. The inducible antibacterial peptides of insects. *Parasitology Today* 10:132–138.
- Codella, Jr., S.G., and K.F. Raffa. 1993. Defense strategies of folivorous sawflies. In *Sawfly Life History Adaptations to Woody Plants* (M.R. Wagner, and K.F. Raffa, Eds.), pp. 261–294. Academic Press, San Diego, CA.
- Coe, M. 1977. The role of termites in the removal of elephant dung in the Tsavo (East) National Park Kenya. *East African Wildlife Journal* 15:49–55.
- Coe, M., and C. Coe. 1987. Large herbivores, acacia trees and bruchid beetles. *South African Journal of Science* 83:624–635.
- Cohen, J.E., and Z.J. Palka. 1990. A stochastic theory of community food webs. V. Intervals and triangulation in the trophic-niche overlap graph. *American Naturalist* 135:435–463.
- Cohen, J.E., F. Briand, and C.M. Newman. 1990. *Community Food Webs: Data and Theory*. Springer-Verlag, Berlin, Germany.
- Colbert, J.J., and R.W. Campbell. 1978. The integrated model. In *The Douglas-fir Tussock Moth: a Synthesis* (M.H. Brookes, R.W. Stark, and R.W. Campbell, Eds.), pp. 216–230. USDA Forest Service, Tech. Bull. 1585, USDA Forest Service, Washington, D.C.
- Cole, L., S.M. Buckland, and R.D. Bardgett. 2008. Influence of disturbance and nitrogen addition on plant and soil animal diversity in grassland. *Soil Biology and Biochemistry* 40:505–514.
- Colegrave, N. 1997. Can a patchy population structure affect the evolution of competition strategies? *Evolution* 51:483–492.
- Coleman, D.C., D.A. Crossley, Jr., and P.F. Hendrix. 2004. *Fundamentals of Soil Ecology*, 2<sup>nd</sup> Ed. Elsevier, Amsterdam, The Netherlands.
- Coleman, D.C., E.P. Odum, and D.A. Crossley, Jr. 1992. Soil biology, soil ecology, and global change. *Biology and Fertility of Soils* 14:104–111.
- Coley, P.D. 1980. Effects of leaf age and plant life history patterns on herbivory. *Nature* 284:545–546.
- Coley, P.D. 1982. Rates of herbivory on different tropical trees. In *The Ecology of a Tropical Forest: Seasonal Rhythms and Long-term Changes* (E.G. Leigh Jr., A.S. Rand, and D.M. Windsor, Eds.), pp. 123–132. Smithsonian Institution Press, Washington, DC.
- Coley, P.D. 1983. Herbivory and defensive characteristics of tree species in a lowland tropical forest. *Ecological Monographs* 53:209–233.
- Coley, P.D. 1986. Costs and benefits of defense by tannins in a neotropical tree. *Oecologia* 70:238–241.
- Coley, P.D., and T.M. Aide. 1991. Comparison of herbivory and plant defenses in temperate and tropical broad-leaved forests. In *Plant–animal Interactions: Evolutionary Ecology in Tropical and Temperate Regions* (P.W. Price, T.M. Lewinsohn, G.W. Fernandes,

- and W.W. Benson, Eds.), pp. 25–49. John Wiley & Sons, Inc, New York, NY.
- Coley, P.D., and J.A. Barone. 1996. Herbivory and plant defenses in tropical forests. *Annual Review of Ecology and Systematics* 27:305–335.
- Coley, P.D., J.P. Bryant, and F.S. Chapin, III. 1985. Resource availability and plant antiherbivore defense. *Science* 230:895–899.
- Collinge, S.K. 2000. Effects of grassland fragmentation on insect species loss, colonization, and movement patterns. *Ecology* 81:2211–2226.
- Collins, N.C., R. Mitchell, and R.G. Wiegert. 1976. Functional analysis of a thermal spring ecosystem, with an evaluation of the role of consumers. *Ecology* 57:1221–1232.
- Collins, N.M. 1981. The role of termites in the decomposition of wood and leaf litter in the southern Guinea savanna of Nigeria. *Oecologia* 51:389–399.
- Collins, N.M. 1983. Termite populations and their role in litter removal in Malaysian rain forests. In *Tropical Rain Forest: Ecology and Management* (S.L. Sutton, T.C. Whitmore, and A.C. Chadwick, Eds.), pp. 311–325. Blackwell, London, UK.
- Combes, S.A., and R. Dudley. 2009. Turbulence-driven instabilities limit insect flight performance. *Proceedings of the National Academy of Sciences, USA* 106:9105–9108.
- Connell, J.H. 1978. Diversity in tropical rain forests and coral reefs. *Science* 199:1302–1310.
- Connell, J.H. 1980. Diversity and the coevolution of competitors, or the ghost of competition past. *Oikos* 35:131–138.
- Connell, J.H. 1983. On the prevalence and relative importance of interspecific competition: evidence from field experiments. *American Naturalist* 122:661–696.
- Connell, J.H., and R.O. Slatyer. 1977. Mechanisms of succession in natural communities and their role in community stability and organization. *American Naturalist* 111:1119–1144.
- Conner, W.E., R. Boada, F.C. Schroeder, A. González, J. Meinwald, and T. Eisner. 2000. Chemical defense: bestowal of a nuptial alkaloidal garment by a male moth on its mate. *Proceedings of the National Academy of Science, USA* 97:14406–14411.
- Contarini, M., K.S. Onufrieva, K.W. Thorpe, K.F. Raffa, and P.C. Tobin. 2009. Mate-finding failure as an important cause of Allee effects along the leading edge of an invading insect population. *Entomologia Experimentalis et Applicata* 133:307–314.
- Cook, D.C., M.B. Thomas, S.A. Cunningham, D.L. Anderson, and P.J. De Barro. 2007. Predicting the economic impact of an invasive species on an ecosystem service. *Ecological Applications* 17:1832–1840.
- Cooper, R.A., and P.C. Molan. 1999. The use of honey as an antiseptic in managing *Pseudomonas* infection. *Journal of Wound Care* 8:161–164.
- Cooper, R.A., P.C. Molan, and K.G. Harding. 1999. Antibacterial activity of honey against strains of *Staphylococcus aureus* from infected wounds. *Journal of the Royal Society of Medicine* 92:283–285.
- Cooper, S.M., and N. Owen-Smith. 1986. Effects of plant spinescence on large mammalian herbivores. *Oecologia* 68:446–455.
- Corbet, P.S. 1962. *A Biology of Dragonflies*. H.F. & G. Witherby, London, UK.
- Corbet, S.A. 1997. Role of pollinators in species preservation, conservation, ecosystem stability and genetic diversity. In *Pollination: from Theory to Practice* (K.W. Richards, Ed.), pp. 219–229. Proc. 7<sup>th</sup> International Symposium on Pollination. Acta Horticulturae #437.
- Correa, S.B., K.O. Winemiller, H. López-Fernández, and M. Galetti. 2007. Evolutionary perspectives on seed consumption and dispersal by fishes. *BioScience* 57:748–756.
- Costa, M.H., and J.A. Foley. 2000. Combined effects of deforestation and doubled atmospheric CO<sub>2</sub> concentrations on the climate of Amazonia. *Journal of Climate* 13:18–34.
- Costantino, R.F., R.A. Desharnais, J.M. Cushing, and B. Dennis. 1997. Chaotic dynamics in an insect population. *Science* 275:389–391.
- Costanza, R., R. d'Arge, R. de Groot, S. Farger, M. Grasso, B. Hannon, K. Limburg, S. Naeem, R.V. O'Neill, J. Paruelo, R.G. Raskin, P. Sutton, and M. van den Belt. 1997. The value of the world's ecosystem services and natural capital. *Nature* 387:253–260.
- Côté, M., J. Ferron, and R. Gagnon. 2005. Invertebrate predation of postdispersal seeds and juvenile seedlings of black spruce (*Picea mariana*) in the boreal forest of eastern Canada. *Canadian Journal of Forest Research* 35:674–681.
- Cotrufo, M.F., M.J.I. Briones, and P. Ineson. 1998. Elevated CO<sub>2</sub> affects field decomposition rate and palatability of tree leaf litter: importance of changes in substrate quality. *Soil Biology and Biochemistry* 12:1565–1571.
- Couceiro, S.R.M., N. Hamada, R.L.M. Ferreira, B.R. Forsberg, and J.O. da Silva. 2007. Domestic sewage and oil spills in streams: effects on edaphic invertebrates in flooded forest, Manaus, Amazonas, Brazil. *Water, Air and Soil Pollution* 180:249–259.
- Coulson, R.N. 1979. Population dynamics of bark beetles. *Annual Review of Entomology* 24:417–447.
- Coulson, R.N., and D.A. Crossley, Jr. 1987. What is insect ecology? A commentary. *Bulletin of the Entomological Society of America* 33:64–68.
- Coulson, R.N., D.N. Pope, J.A. Gagne, W.S. Fargo, P.E. Pulley, L.J. Edson, and T.L. Wagner. 1980. Impact of foraging by *Monochamus titillator* (Col.: Cerambycidae) on within-tree populations of *Dendroctonus frontalis* (Col.: Scolytidae). *Entomophaga* 25:155–170.

- Coulson, R.N., P.B. Hennier, R.O. Flamm, E.J. Rykiel, L.C. Hu, and T.L. Payne. 1983. The role of lightning in the epidemiology of the southern pine beetle. *Zeitschrift für angewandte Entomologie* 96:182–193.
- Coulson, R.N., R.O. Flamm, P.E. Pulley, T.L. Payne, E.J. Rykiel, and T.L. Wagner. 1986. Response of the southern pine bark beetle guild (Coleoptera: Scolytidae) to host disturbance. *Environmental Entomology* 15:850–858.
- Coulson, R.N., J.W. Fitzgerald, B.A. McFadden, P.E. Pulley, C.N. Lovelady, and J.R. Giardino. 1996. Functional heterogeneity of forest landscapes: how host defenses influence epidemiology of the southern pine beetle. In *Dynamics of Forest Herbivory: Quest for Pattern and Principle* (W.J. Mattson, P. Niemela, and M. Rousi, Eds.), pp. 272–286. USDA Forest Serv. Gen. Tech. Rep. NC-183. USDA Forest Serv., North Central Forest Exp. Stn, St. Paul, MN.
- Courtney, S.P. 1985. Apparency in coevolving relationships. *Oikos* 44:91–98.
- Courtney, S.P. 1986. The ecology of pierid butterflies: dynamics and interactions. *Advances in Ecological Research* 15:51–131.
- Coûteaux, M.M., M. Mousseau, M.L. Célérier, and P. Bottner. 1991. Increased atmospheric CO<sub>2</sub> and litter quality: decomposition of sweet chestnut leaf litter with animal food webs of different complexities. *Oikos* 61:54–64.
- Covich, A.P., and W.H. McDowell. 1996. The stream community. In *The Food Web of a Tropical Rain Forest* (D.P. Reagan, and R.B. Waide, Eds.), pp. 433–459. University of Chicago Press, Chicago, IL.
- Covich, A.P., T.A. Crowl, C.L. Hein, M.J. Townsend, and W.H. McDowell. 2009. Predator–prey interactions in river networks: comparing shrimp spatial refugia in two drainage basins. *Freshwater Biology* 54:450–465.
- Cowles, H.C. 1911. The causes of vegetative cycles. *Botanical Gazette* 51:161–183.
- Cowling, R.M., S.M. Pierce, W.D. Stock, and M. Cocks. 1994. Why are there so many myrmecochorous species in the Cape fynbos? In *Plant–animal Interactions in Mediterranean-type Ecosystems* (M. Arianoutsou, and R.H. Graves, Eds.), pp. 159–168. Kluwer, Dordrecht, The Netherlands.
- Cox-Foster, D.L., S. Conlan, E.C. Holmes, G. Palacios, J.D. Evans, N.A. Moran, P.-L. Quan, T. Briese, M. Hornig, D.M. Geiser, V. Martinson, D. vanEngelsdorp, A.L. Kalkstein, A. Drysdale, J. Hui, J. Zhai, L. Cui, S.K. Hutchison, J.F. Simons, M. Egholm, J.S. Pettis, and W.I. Lipkin. 2007. A metagenic survey of microbes in honey bee colony collapse disorder. *Science* 318:283–287.
- Coxson, D.S., and N.M. Nadkarni. 1995. Ecological roles of epiphytes in nutrient cycles of forest canopies. In *Forest Canopies* (M.D. Lowman, and N.M. Nadkarni, Eds.), pp. 495–453. Academic Press, San Diego, CA.
- Crane, E. 1999. *The World History of Beekeeping and Honey Hunting*. Routledge, New York, NY.
- Crawford, C.S. 1978. Seasonal water balance in *Orthoporus ornatus*, a desert millipede. *Ecology* 59:996–1004.
- Crawford, C.S. 1986. The role of invertebrates in desert ecosystems. In *Pattern and Process in Desert Ecosystems* (W.G. Whitford, Ed.), pp. 73–91. University of New Mexico Press, Albuquerque, NM.
- Crawley, M.J. 1983. *Herbivory: the Dynamics of Animal–plant Interactions*. University of California Press, Berkeley CA.
- Crawley, M.J. 1989. Insect herbivores and plant population dynamics. *Annual Review of Entomology* 34:531–564.
- Creelman, R.A., and J.E. Mullet. 1997. Biosynthesis and action of jasmonates in plants. *Annual Review of Plant Physiology and Plant Molecular Biology* 48:355–381.
- Cregg, B.M., and M.E. Dix. 2001. Tree moisture stress and insect damage in urban areas in relation to heat island effects. *Journal of Arboriculture* 27:8–17.
- Croft, B.A. 1990. *Arthropod Biological Control Agents and Pesticides*. Wiley, New York, NY.
- Croft, B.A., and A.P. Gutierrez. 1991. Systems analysis role in modeling and decision-making. In *Entomology Serving Society: Emerging Technologies and Challenges* (S.B. Vinson, and R.L. Metcalf, Eds.), pp. 298–319. Entomological Society of America, Lanham, MD.
- Croft, B.A., and D.H. Slone. 1997. Equilibrium densities of European red mite (Acari: Tetranychidae) after exposure to three levels of predaceous mite diversity on apple. *Environmental Entomology* 26:391–399.
- Cromack, K., Jr., and C.D. Monk. 1975. Litter production, decomposition, and nutrient cycling in a mixed-hardwood watershed and a white pine watershed. In *Mineral Cycling in Southeastern Ecosystems* (F.G. Howell, J.B. Gentry, and M.H. Smith, Eds.), pp. 609–624. U.S. Energy Research and Development Administration. Technical Information Center, Washington, DC.
- Cromack, K., Jr., R.L. Todd, and C.D. Monk. 1975. Patterns of basidiomycete nutrient accumulation in conifer and deciduous forest litter. *Soil Biology and Biochemistry* 7:265–268.
- Cromack, K., Jr., P. Sollins, R.L. Todd, D.A. Crossley, Jr., W.M. Fender, R. Fogel, and A.W. Todd. 1977. Soil microorganism–arthropod interactions: fungi as major calcium and sodium sources. In *The Role of Arthropods in Forest Ecosystems* (W.J. Mattson, Ed.), pp. 78–84. Springer-Verlag, New York, NY.
- Cromartie, W.J., Jr., 1975. The effect of stand size and vegetational background on the colonization of cruciferous plants by herbivorous insects. *Journal of Applied Ecology* 12:517–533.
- Cronin, J.T. 2003. Matrix heterogeneity and host–parasitoid interactions in space. *Ecology* 84:1506–1516.

- Cronin, J.T., and D.R. Strong. 1999. Dispersal-dependent oviposition and the aggregation of parasitism. *American Naturalist* 154:23–36.
- Cronin, J.T., J.D. Reeve, R. Wilkens, and P. Turchin. 2000. The pattern and range of movement of a checkered beetle predator relative to its bark beetle prey. *Oikos* 90:127–138.
- Cronin, J.T., W.G. Abrahamson, and T.P. Craig. 2001. Temporal variation in herbivore host–plant preference and performance: constraints on host–plant adaptation. *Oikos* 93:312–320.
- Cronin, J.T., K.J. Haynes, and F. Dilleuth. 2004. Spider effects on planthopper mortality, dispersal, and spatial population dynamics. *Ecology* 85:2134–2143.
- Crossley, D.A. Jr., 1966. Radioisotope measurement of food consumption by a leaf beetle species *Chrysomela knabi* Brown. *Ecology* 47:1–8.
- Crossley, D.A. Jr., 1977. The roles of terrestrial saprophagous arthropods in forest soils: current status of concepts. In *The Role of Arthropods in Forest Ecosystems* (W.J. Mattson, Ed.), pp. 49–56. Springer-Verlag, New York, NY.
- Crossley, D.A., Jr., and M.P. Høglund. 1962. A litter-bag method for the study of microarthropods inhabiting leaf litter. *Ecology* 43:571–573.
- Crossley, D.A., Jr., and H.F. Howden. 1961. Insect–vegetation relationships in an area contaminated by radioactive wastes. *Ecology* 42:302–317.
- Crossley, D.A., Jr., and M. Witkamp. 1964. Effects of pesticide on biota and breakdown of forest litter. In *Proc. 8<sup>th</sup> International Congress of Soil Science, Bucharest, Romania* pp. 887–892. Publishing House of the Academy of the Socialist, Republic of Romania.
- Crossley, D.A., Jr., E.R. Blood, P.F. Hendrix, and T.R. Seastedt. 1995. Turnover of cobalt-60 by earthworms (*Eisenia foetida*) (Lumbricidae, Oligochaeta). *Applied Soil Ecology* 2:71–75.
- Crutsinger, G.M., M.D. Collins, J.A. Fordyce, Z. Gompert, C.C. Nice, and N.J. Sanders. 2006. Plant genotypic diversity predicts community structure and governs an ecosystem process. *Science* 313:966–968.
- Crutsinger, G.M., M.N. Habenicht, A.T. Classen, J.A. Schweitzer, and N.J. Sanders. 2008. Galling by *Rhopalomyia solidaginis* alters *Solidago altissima* architecture and litter nutrient dynamics in an old-field ecosystem. *Plant and Soil* 303:95–103.
- Cuffney, T.F., J.B. Wallace, and G.J. Lughart. 1990. Experimental evidence quantifying the role of benthic invertebrates in organic matter dynamics in headwater streams. *Freshwater Biology* 23:281–299.
- Culver, D.C., and A.J. Beattie. 1980. The fate of *Viola* seeds dispersed by ants. *American Journal of Botany* 67:710–714.
- Culver, D.C., and A.J. Beattie. 1983. Effects of ant movements on soil chemistry and vegetation patterns in a Colorado montane meadow. *Ecology* 64:485–492.
- Cummins, K.W. 1973. Trophic relations of aquatic insects. *Annual Review of Entomology* 18:183–206.
- Cunningham, J.P., S.A. West, and D.J. Wright. 1998. Learning in the nectar foraging behaviour of *Helicoverpa armigera*. *Ecological Entomology* 23:363–369.
- Cunningham, J.P., M.P. Zalucki, and S.A. West. 1999. Learning in *Helicoverpa armigera* (Lepidoptera: Noctuidae): a new look at the behaviour and control of a phytophagous pest. *Bulletin of Entomological Research* 89:201–207.
- Curran, E.D., P. Wilf, S.L. Wing, C.C. Labandeira, E.C. Lovelock, and D.L. Royer. 2008. Sharply increased insect herbivory during the Paleocene-Eocene Thermal Maximum. *Proceedings of the National Academy of Sciences, USA* 105:1960–1964.
- Currie, C.R. 2001. A community of ants, fungi, and bacteria: a multilateral approach to studying symbiosis. *Annual Review of Microbiology* 55:357–380.
- Currie, C.R., U.G. Mueller, and D. Malloch. 1999a. The agricultural pathology of ant fungus gardens. *Proceedings of the National Academy of Sciences, USA* 96:7998–8002.
- Currie, C.R., J.A. Scott, R.C. Summerbell, and D. Malloch. 1999b. Fungus-growing ants use antibiotic-producing bacteria to control garden parasites. *Nature* 398:701–704.
- Currie, D.J. 1991. Energy and large-scale patterns of animal- and plant-species richness. *American Naturalist* 137:27–49.
- Curry, J.P. 1994. *Grassland Invertebrates*. Chapman & Hall, London, UK.
- Cushing, J.M., R.F. Costantino, B. Dennis, R.A. Desharnais, and S.M. Henson. 2003. *Chaos in Ecology: Experimental Nonlinear Dynamics*. Academic/Elsevier, San Diego, CA.
- Cushman, J.H., and J.F. Addicott. 1991. Conditional interactions in ant–plant–herbivore mutualisms. In *Ant–plant Interactions* (C.R. Huxley, and D.F. Cutler, Eds.), pp. 92–103. Oxford University Press, Oxford, UK.
- Daily, G.C. (Ed.) 1997. *Nature's Services: Societal Dependence on Natural Ecosystems*. Island Press, Washington, DC.
- Daly, K.C., M.L. Durtschi, and B.H. Smith. 2001. Olfactory-based discrimination learning in the moth, *Manduca sexta*. *Journal of Insect Physiology* 47:375–384.
- Dambacher, J.M., H.W. Li, and P.A. Rossignol. 2002. Relevance of community structure in assessing indeterminacy of ecological predictions. *Ecology* 83:1372–1385.
- Dambacher, J.M., H.W. Li, J.O. Wolff, and P.A. Rossignol. 1999. Parsimonious interpretation of the impact of vegetation, food, and predation on snowshoe hare. *Oikos* 84:530–532.
- Dambacher, J.M., H.-K. Luh, H.W. Li, and P.A. Rossignol. 2003. Qualitative stability and ambiguity in model ecosystems. *American Naturalist* 161:876–888.

- Dangerfield, J.M. 1994. Ingestion of leaf litter by millipedes: the accuracy of laboratory estimates for predicting litter turnover in the field. *Pedobiologia* 38:262–265.
- Dangerfield, J.M., T.S. McCarthy, and W.N. Ellery. 1998. The mound-building termite *Macrotermes michaelsoni* as an ecosystem engineer. *Journal of Tropical Ecology* 14:507–520.
- Darlington, P.J. 1943. Carabidae of mountains and islands: data on the evolution of isolated faunas, and on atrophy of wings. *Ecological Monographs* 13:37–61.
- Darwin, C. 1859. *The Origin of Species by Means of Natural Selection or the Preservation of Favored Races in the Struggle for Life*. Murray, London, UK.
- Dasgupta, P., S. Levin, and J. Lubchenco. 2000. Economic pathways to ecological sustainability. *BioScience* 50:339–345.
- Dauber, J., and V. Wolters. 2000. Microbial activity and functional diversity in the mounds of three different ant species. *Soil Biology and Biochemistry* 32:93–99.
- Dauber, J., J.C. Biesmeijer, D. Gabriel, W.E. Kunin, E. Lamborn, B. Meyer, A. Nielsen, S.G. Potts, S.P.M. Roberts, V. Söber, J. Settele, I. Steffan-Dewenter, J.C. Stout, T. Teder, T. Tscheulin, D. Vivarelli, and T. Petanidou. 2010. Effects of patch size and density on flower visitation and seed set of wild plants: a pan-European approach. *Journal of Ecology* 98:188–196.
- Daufresne, T., and M. Loreau. 2001. Ecological stoichiometry, primary producer–decomposer interactions, and ecosystem persistence. *Ecology* 82:3069–3082.
- Davidson, D.W. 1993. The effects of herbivory and granivory on terrestrial plant succession. *Oikos* 68:23–35.
- Davidson, D.W., and B.L. Fisher. 1991. Symbiosis of ants with *Cecropia* as a function of light regime. In *Ant–plant Interactions* (C.R. Huxley, and D.F. Cutler, Eds.), pp. 289–309. Oxford University Press, Oxford, UK.
- Davidson, D.W., R.S. Inouye, and J.H. Brown. 1984. Granivory in a desert ecosystem: experimental evidence for indirect facilitation of ants by rodents. *Ecology* 65:1780–1786.
- Davies, P.E., and M. Nelson. 1994. Relationship between riparian buffer widths and the effect of logging in stream habitat, invertebrate community response and fish abundance. *Australian Journal of Marine and Freshwater Research* 45:1289–1305.
- Davis, A.L.V. 1996. Seasonal dung beetle activity and dung dispersal in selected South African habitats: implications for pasture improvement in Australia. *Agriculture, Ecosystems and Environment* 58:157–169.
- Davis, R.L. 2005. Olfactory memory formation in *Drosophila*: from molecular to systems neuroscience. *Annual Review of Neuroscience* 28:275–302.
- Davis, T.S., and R.W. Hofstetter. 2009. Effects of gallery density and species ratio on the fitness and fecundity of two sympatric bark beetles (Coleoptera: Curculionidae). *Environmental Entomology* 38:639–650.
- Davison, E.A. 1987. Respiration and energy flow in two Australian species of desert harvester ants, *Chelaner rothsteini* and *Chelaner whitei*. *Journal of Arid Environments* 12:61–82.
- Day, J.F., J.D. Edman, S.E. Kunz, and S.K. Wikel. 2000. Direct injury: phobias, psychoses, annoyance, allergies, toxins, venoms and myiasis. In *Medical Entomology* (B.F. Eldridge, and J.D. Edman, Eds.), pp. 99–149. Kluwer Academic Publishers, Dordrecht, The Netherlands.
- Day, M.F., and H. Rzykiewicz. 1953. Feeding behavior of the aphids *Myzus persicae* and *Brevicoryne brassicae*, studied with radiophosphorus. *Australian Journal of Biological Science* 6:98–108.
- Day, M.F., and A. McKinnon. 1951. A study of some aspects of the feeding of the jassid *Orosius*. *Australian Journal of Scientific Research (B)* 4:125–135.
- Dean, A.M. 1983. A simple model of mutualism. *American Naturalist* 121:409–417.
- de Carvalho, E.L., and M. Kogan. 1991. Order Strepsiptera. In *Immature Insects*, Vol. 2. (Stehr F., Ed.), pp. 659–673. Kendall/Hunt, Dubuque, IA.
- Dedej, S., and K.S. Delaplane. 2004. Nectar-robbing carpenter bees reduce seed-setting capability of honey bees (Hymenoptera: Apidae) in rabbiteye blueberry, *Vaccinium ashei*, ‘Climax’. *Environmental Entomology* 33:100–106.
- Deevey, E.S. 1947. Life tables for natural populations of animals. *Quarterly Review of Biology* 22:283–314.
- DeFoliart, G.R. 1999. Insects as food: why the Western attitude is important. *Annual Review of Entomology* 44:21–50.
- Degen, B., and D.W. Roubik. 2004. Effects of animal pollination on pollen dispersal, selfing, and effective population size of tropical trees: a simulation study. *Biotropica* 36:165–179.
- de la Cruz, M., and R. Dirzo. 1987. A survey of the standing levels of herbivory in seedlings from a Mexican rain forest. *Biotropica* 19:98–106.
- Delfosse, E.S. 2005. Risk and ethics in biological control. *Biological Control* 35:319–329.
- Delphin, F. 1965. The histology and possible functions of neurosecretory cells in the ventral ganglia of *Schistocerca gregaria* Forskal (Orthoptera: Acrididae). *Transaction of the Royal Entomological Society London* 117:167–214.
- de Mazancourt, C., M. Loreau, and L. Abbadie. 1998. Grazing optimization and nutrient cycling: when do herbivores enhance plant production? *Ecology* 79:2242–2252.
- de Mazancourt, C., E. Johnson, and T.G. Barradough. 2008. Biodiversity inhibits species’ evolutionary responses to changing environments. *Ecology Letters* 11:380–388.

- DeMers, M.N. 1993. Roadside ditches as corridors for range expansion of the western harvester ant (*Pogonomyrmex occidentalis* Cresson). *Landscape Ecology* 8:93–102.
- Demir, E., and B.J. Dickson. 2005. Fruitless splicing specifies male courtship behavior in *Drosophila*. *Cell* 121:785–794.
- Denlinger, D.L. 2002. Regulation of diapause. *Annual Review of Entomology* 47:93–122.
- Dennis, B., R.A. Desharnais, J.M. Cushing, S.M. Henson, and R.F. Costantino. 2001. Estimating chaos and complex dynamics in an insect population. *Ecological Monographs* 71:277–303.
- Denno, R.F., M.S. McClure, and J.R. Ott. 1995. Interspecific interactions in phytophagous insects: competition reexamined and resurrected. *Annual Review of Entomology* 40:297–331.
- Denno, R.F., C. Gratton, M.A. Peterson, G.A. Langellotto, D.L. Finke, and A.F. Huberty. 2002. Bottom-up forces mediate natural-enemy impact in a phytophagous insect community. *Ecology* 83:1443–1458.
- Denno, R.F., C. Gratton, H. Döbel, and D.L. Finke. 2003. Predation risk affects relative strength of top-down and bottom-up impacts on insect herbivores. *Ecology* 84:1032–1044.
- Denno, R.F., M.S. Mitter, G.A. Langellotto, C. Gratton, and D.L. Finke. 2004. Interactions between a hunting spider and a web-builder: consequences of intraguild predation and cannibalism for prey suppression. *Ecological Entomology* 29:566–577.
- Denslow, J.S. 1985. Disturbance-mediated coexistence of species. In *Ecology of Natural Disturbance and Patch Dynamics* (S.T.A. Pickett, and P.S. White, Eds.), pp. 307–323. Academic Press, Orlando, FL.
- Denslow, J.S. 1995. Disturbance and diversity in tropical rain forests: the density effect. *Ecological Applications* 5:962–968.
- Denys, C., and T. Tscharrntke. 2002. Plant–insect communities and predator–prey ratios in field margin strips, adjacent crop fields, and fallows. *Oecologia* 130:315–324.
- DeRouen, S.M., L.D. Foil, A.J. MacKay, D.E. Fanke, D.W. Sanson, and W.E. Wyatt. 2003. Effect of horn fly (*Haematobia irritans*) control on growth and reproduction of beef heifers. *Journal of Economic Entomology* 96:1612–1616.
- de Ruiter, P.C., A.M. Neutel, and J.C. Moore. 1995. Energetics, patterns of interaction strengths, and stability in real ecosystems. *Science* 269:1257–1260.
- de Souza-Stevauz, M.C., R.R.B. Negrelle, and V. Citadini-Zanette. 1994. Seed dispersal by the fish *Pterodoras granulosus* in the Paraná River Basin, Brazil. *Journal of Tropical Ecology* 10:621–626.
- Detling, J.K. 1987. Grass response to herbivory. In *Integrated Pest Management on Rangeland: a Short-grass Prairie Perspective* (J.L. Capinera, Ed.), pp. 56–68. Westview Press, Boulder, CO.
- Detling, J.K. 1988. Grasslands and savannas: regulation of energy flow and nutrient cycling by herbivores. In *Ecosystems: Analysis and Synthesis* (L.R. Pomeroy, and J.A. Alberts, Eds.), pp. 131–148. Springer-Verlag, New York, NY.
- Detling, J.K., M.I. Dyer, C. Procter-Gregg, and D.T. Winn. 1980. Plant–herbivore interactions: examination of potential effects of bison saliva on regrowth of *Bouteloua gracilis* (H.B.K.) Lag. *Oecologia* 45:26–31.
- Dévai, G., and J. Moldován. 1983. An attempt to trace eutrophication in a shallow lake (Balaton, Hungary) using chironomids. *Hydrobiologia* 103:169–175.
- Dial, R., and J. Roughgarden. 1995. Experimental removal of insectivores from rain forest canopy: direct and indirect effects. *Ecology* 76:1821–1834.
- Dial, R., and J. Roughgarden. 1996. Natural history observations of *Anolisomyia rufianalis* (Diptera: Sarcophagidae) infesting *Anolis* lizards in a rain forest canopy. *Environmental Entomology* 25:1325–1328.
- Diamond, J.M. 1990. Biological effects of ghosts. *Nature* 345:769–770.
- Diamond, J. 1999. Guns, Germs, and Steel: the Fates of Human Societies. W.W. Norton, New York, NY.
- Diamond, J.M., and R.M. May. 1981. Island biogeography and the design of natural reserves. In *Theoretical Ecology: Principles and Applications* (R.M. May, Ed.), pp. 228–252. Blackwell, Oxford, UK.
- Didham, R.K., J. Ghazoul, N.E. Stork, and A.J. Davis. 1996. Insects in fragmented forests: a functional approach. *Trends in Ecology and Evolution* 11:255–260.
- Dik, A.J., and J.A. van Pelt. 1993. Interaction between phyllosphere yeasts, aphid honeydew and fungicide effectiveness in wheat under field conditions. *Plant Pathology* 41:661–675.
- Dirzo, R. 1984. Herbivory: a phytocentric overview. In *Perspectives on Plant Population Ecology* (R. Dirzo, and J. Sarukhán, Eds.), pp. 141–165. Sinauer Assoc., Inc, Sunderland, MA.
- Dixon, A.F.G. 1985. Aphid Ecology. Blackie & Son Ltd., Glasgow, UK.
- Dodds, K.J., C. Graber, and F.M. Stephen. 2001. Facultative intraguild predation by larval Cerambycidae (Coleoptera) on bark beetle larvae (Coleoptera: Scolytidae). *Environmental Entomology* 30:17–22.
- Doi, H. 2009. Spatial patterns of autochthonous and allochthonous resources in aquatic food webs. *Population Ecology* 51:57–64.
- Dolch, R., and T. Tscharrntke. 2000. Defoliation of alders (*Alnus glutinosa*) affects herbivory by leaf beetles on undamaged neighbors. *Oecologia* 125:504–511.
- Domisch, T., L. Finér, M. Ohashi, A.C. Risch, L. Sundström, P. Niemelä, and M.F. Jurgensen. 2006. Contribution of red wood ant mounds to forest floor CO<sub>2</sub> efflux in boreal coniferous forests. *Soil Biology and Biochemistry* 38:2425–2433.

- Donald, P.F., and A.D. Evans. 2006. Habitat connectivity and matrix restoration: the wider implications of agri-environmental schemes. *Journal of Applied Ecology* 43:209–218.
- Dowding, P. 1984. The evolution of insect–fungus relationships in the primary invasion of forest timber. In *Invertebrate Microbial Interactions* (J.M. Anderson, A.D.M. Rayner, and D.W.H. Walton, Eds.), pp. 135–153. British Mycological Society Symposium 6, Cambridge University Press, Cambridge, UK.
- Downes, J.A. 1970. The feeding and mating behaviour of the specialized Empididae (Diptera); observations on four species of *Rhamphomyia* in the high Arctic and a general discussion. *Canadian Entomologist* 102:769–791.
- Downing, A.L., and M.A. Leibold. 2002. Ecosystem consequences of species richness and composition in pond food webs. *Nature* 416:837–841.
- Downing, K.B., and W.R. Williams. 1978. Douglas-fir tussock moth: did it affect private recreational businesses in northeastern Oregon?. *Journal of Forestry* 76:29–30.
- Doyle, R.D., M. Grodowitz, R.M. Smart, and C. Owens. 2002. Impact of herbivory by *Hydrellia pakistanae* (Diptera: Ephydriidae) on growth and photosynthetic potential of *Hydrilla verticillata*. *Biological Control* 24:221–229.
- Doyle, T.W. 1981. The role of disturbance in the gap dynamics of a montane rain forest: an application of a tropical forest succession model. In *Forest Succession: Concepts and Application* (D.C. West, H.H. Shugart, and D.B. Botkin, Eds.), pp. 56–73. Springer-Verlag, New York, NY.
- Dreisi g, H. 1988. Foraging rate of ants collecting honeydew or extrafloral nectar and some possible constraints. *Ecological Entomology* 13:143–154.
- Drew, A.P., J.D. Boley, Y. Zhao, M.H. Johnston, and F.H. Wadsworth. 2009. Sixty-two years of change in subtropical wet forest structure and composition at El Verde, Puerto Rico. *Interciencia* 34:34–40.
- Drukker, B., J. Bruin, and M.W. Sabelis. 2000. Anthocorid predators learn to associate herbivore-induced plant volatiles with presence or absence of prey. *Physiological Entomology* 25:260–265.
- Drury, W.H., and I.C.T. Nisbet. 1973. Succession. *Journal of the Arnold Arboretum* 54:331–368.
- Dudt, J.F., and D.J. Shure. 1994. The influence of light and nutrients on foliar phenolics and insect herbivory. *Ecology* 75:86–98.
- Duffy, J.E. 2009. Why biodiversity is important to the functioning of real-world ecosystems. *Frontiers in Ecology and the Environment* 7:437–444.
- Dufr ne, M., and P. Legendre. 1997. Species assemblages and indicator species: the need for a flexible asymmetrical approach. *Ecological Monographs* 67:345–366.
- Dukas, R. 2008. Evolutionary biology of insect learning. *Annual Review of Entomology* 53:145–160.
- Dukas, R., and L.A. Real. 1993. Cognition in bees: from stimulus reception to behavioral change. In *Insect Learning: Ecological and Evolutionary Perspectives* (D.R. Papaj, and A.C. Lewis, Eds.), pp. 343–373. Chapman & Hall, New York, NY.
- Duncan, D.H., A.B. Nicotra, J.T. Wood, and S.A. Cunningham. 2004. Plant isolation reduces outcross pollen receipt in a partially self-compatible herb. *Journal of Ecology* 92:977–985.
- Dungan, R.J., M.H. Turnbull, and D. Kelly. 2007. The carbon costs for host trees of a phloem-feeding herbivore. *Journal of Ecology* 95:603–613.
- Dunn, P.E., T.J. Bohnert, and V. Russell. 1994. Regulation of antibacterial protein synthesis following infection and during metamorphosis of *Manduca sexta*. *Annals of the New York Academy of Sciences* 712:117–130.
- Dunn, R.R., D. Agosti, A.N. Andersen, X. Arnan, C.A. Bruhl, X. Cerd a, A.M. Ellison, B.L. Fisher, M.C. Fitzpatrick, H. Gibb, N.J. Gotelli, A.D. Gove, B. Guenard, M. Janda, M. Kaspari, E.J. Laurent, J.-P. Lessard, J.T. Longino, J.D. Majer, S.B. Menke, T.P. McGlynn, C.L. Parr, S.M. Philpott, M. Pfeiffer, J. Retana, A.V. Suarez, H.L. Vasconcelos, M.D. Weiser, and N.J. Sanders. 2009. Climatic drivers of hemispheric asymmetry in global patterns of ant species richness. *Ecology Letters* 12:324–333.
- Dwyer, G., J. Dushoff, and S.H. Yee. 2004. The combined effects of pathogens and predators on insect outbreaks. *Nature* 430:341–345.
- Dyer, F.C. 2002. The biology of the dance language. *Annual Review of Entomology* 47:917–949.
- Dyer, L.A. 1995. Tasty generalists and nasty specialists? Antipredator mechanisms in tropical lepidopteran larvae. *Ecology* 76:1483–1496.
- Dyer, L.A., and D.K. Letourneau. 1999a. Relative strengths of top-down and bottom-up forces in a tropical forest community. *Oecologia* 119:265–274.
- Dyer, L.A., and D.K. Letourneau. 1999b. Trophic cascades in a complex terrestrial community. *Proceedings of the National Academy of Sciences, USA* 96:5072–5076.
- Dyer, L.A., G.D. Dodson, J. Beihoffer, and D.K. Letourneau. 2001. Trade-offs in antiherbivore defenses in *Piper cenocladum*: ant mutualists versus plant secondary metabolites. *Journal of Chemical Ecology* 27:581–592.
- Dyer, L.A., M.S. Singer, J.T. Lill, J.O. Stireman, G.L. Gentry, R.J. Marquis, R.E. Ricklefs, H.F. Greeney, D.L. Wagner, H.C. Morais, I.R. Diniz, T.A. Kursar, and P.D. Coley. 2007. Host specificity of Lepidoptera in tropical and temperate forests. *Nature* 448:696–700.
- Dyer, M.I., M.A. Acra, G.M. Wang, D.C. Coleman, D.W. Freckman, S.J. McNaughton, and B.R. Strain. 1991. Source-sink carbon relations in two *Panicum coloratum* ecotypes in response to herbivory. *Ecology* 72:1472–1483.



- Dyer, M.I., A.M. Moon, M.R. Brown, and D.A. Crossley, Jr. 1995. Grasshopper crop and midgut extract effects on plants: an example of reward feedback. *Proceedings of the National Academy of Sciences, USA* 92:5475–5478.
- Dyer, M.I., C.L. Turner, and T.R. Seastedt. 1993. Herbivory and its consequences. *Ecological Applications* 3:10–16.
- Edelaar, P., A.M. Siepielski, and J. Clobert. 2008. Matching habitat choice causes directed gene flow: a neglected dimension in evolution and ecology. *Evolution* 62:2462–2472.
- Edman, J.D. 2000. Arthropod transmission of vertebrate parasites. In *Medical Entomology* (B.F. Eldridge, and J.D. Edman, Eds.), pp. 151–163. Kluwer Academic Publishers, Dordrecht, The Netherlands.
- Edmonds, R.L., and A. Eglitis. 1989. The role of the Douglas-fir beetle and wood borers in the decomposition of and nutrient release from Douglas-fir logs. *Canadian Journal of Forest Research* 19:853–859.
- Edmunds, G.F., Jr., and D.N. Alstad. 1978. Coevolution in insect herbivores and conifers. *Science* 199:941–945.
- Edmunds, G.F., Jr., and D.N. Alstad. 1985. Malathion-induced sex ratio changes in black pineleaf scale (Hemiptera: Diaspididae). *Annals of the Entomological Society of America* 78:403–405.
- Edney, E.B. 1977. *Water Balance in Land Arthropods*. Springer-Verlag, Berlin.
- Edson, K.M., S.B. Vinson, D.B. Stoltz, and M.D. Summers. 1981. Virus in a parasitoid wasp: suppression of the cellular immune response in the parasitoid's host. *Science* 211:582–583.
- Edwards, C.A., and G.W. Heath. 1963. The role of soil animals in breakdown of leaf material. In *Soil Organisms* (J. Doeksen, and J. van der Drift, Eds.), pp. 76–84. North-Holland, Amsterdam, The Netherlands.
- Edwards, C.A., and J.R. Lofty. 1978. The influence of arthropods and earthworms upon root growth of direct drilled cereals. *Journal of Applied Ecology* 15:789–795.
- Edwards, E.P. 1982. Hummingbirds feeding on an excretion produced by scale insects. *Condor* 84:122.
- Edwards, J.S., and P. Sugg. 1990. Arthropod fallout as a resource in the recolonization of Mt. St. Helens. *Ecology* 74:954–958.
- Edwards, N.T. 1982. The use of soda-lime for measuring respiration rates in terrestrial systems. *Pedobiologia* 23:321–330.
- Edwards, P.J. 1989. Insect herbivory and plant defence theory. In *Toward a More Exact Ecology* (P.J. Grubb, and J.B. Whittaker, Eds.), pp. 275–297. Blackwell Scientific, Oxford, UK.
- Effler, R.S., R.A. Goyer, and G.J. Lenhard. 2006. Baldcypress and water tupelo responses to insect defoliation and nutrient augmentation in Maurepas Swamp, Louisiana, USA. *Forest Ecology and Management* 236:295–304.
- Eggert, A.-K., M. Reinking, and J.K. Miller. 1998. Parental care improves offspring survival and growth in burying beetles. *Animal Behavior* 55:97–107.
- Eggert, S.L., and J.B. Wallace. 2003. Reduced detrital resources limit *Pycnopsyche gentilis* (Trichoptera: Limnephilidae) production and growth. *Journal of the North American Benthological Society* 22:388–400.
- Eggert, S.L., and J.B. Wallace. 2007. Wood biofilm as a food resource for stream detritivores. *Limnology and Oceanography* 52:1239–1245.
- Egler, F.E. 1954. Vegetation science concepts. I. initial floristic composition, a factor in old-field vegetation development. *Vegetatio* 4:412–417.
- Ehrlén, J. 1996. Spatiotemporal variation in predispersal seed predation intensity. *Oecologia* 108:708–713.
- Eisner, T., R.E. Silberglied, D. Aneshansley, J.E. Carrel, and H.C. Howland. 1969. Ultraviolet videoviewing: the television camera as an insect eye. *Science* 166:1172–1174.
- Elder, B.D. 2006. Disturbance-mediated trophic interactions and plant performance. *Oecologia* 147:261–271.
- Elder, B.D., and D.F. Doak. 2006. Comparing the direct and community-mediated effects of disturbance on plant population dynamics: flooding, herbivory and *Mimulus guttatus*. *Journal of Ecology* 94:656–669.
- Elder, B.D., J. Dushoff, and G. Dwyer. 2008. Host-pathogen interactions, insect outbreaks, and natural selection for disease resistance. *American Naturalist* 172:829–842.
- Eldridge, D.J. 1993. Effect of ants on sandy soils in semi-arid eastern Australia: local distribution of nest entrances and their effect on infiltration of water. *Australian Journal of Soil Research* 31:509–518.
- Eldridge, D.J. 1994. Nests of ants and termites influence infiltration in a semi-arid woodland. *Pedobiologia* 38:481–492.
- Elkins, N.Z., G.V. Sabol, T.J. Ward, and W.G. Whitford. 1986. The influence of subterranean termites on the hydrological characteristics of a Chihuahuan Desert ecosystem. *Oecologia* 68:521–528.
- Elkinton, J.S., C. Schal, T. Ono, and R.T. Cardé. 1987. Pheromone puff trajectory and upwind flight of male gypsy moths in a forest. *Physiological Entomology* 12:399–406.
- Elliott, E.T., D.C. Coleman, R.E. Ingham, and J.A. Trofymow. 1984. Carbon and energy flow through microflora and microfauna in the soil subsystem of terrestrial ecosystems. In *Current Perspectives in Microbial Ecology* (M.J. Klug, and C.A. Reddy, Eds.), pp. 424–433. American Society for Microbiology, Washington, DC.
- Elliott, N.C., G.A. Simmons, and F.J. Sapio. 1987. Honeydew and wildflowers as food for the parasites *Glypta fumiferanae* (Hymenoptera: Ichneumonidae) and *Apanteles fumiferanae* (Hymenoptera:

- Braconidae). *Journal of the Kansas Entomological Society* 60:25–29.
- Elsler, J.J., and J. Urabe. 1999. The stoichiometry of consumer-driven nutrient recycling: theory, observations, and consequences. *Ecology* 80:735–751.
- Elsler, J.J., D.R. Dobberfuhl, N.A. MacKay, and J.H. Schampel. 1996. Organism size, life history, and N:P stoichiometry: toward a unified view of cellular and ecosystem processes. *BioScience* 46:674–684.
- Elton, C. 1939. *Animal Ecology*. Macmillan, New York, NY.
- Elvidge, C.D., C. Milesi, J.B. Dietz, B.T. Tuttle, P.C. Sutton, R. Nemani, and J.E. Vogelmann. 2004. U.S. constructed area approaches the size of Ohio. *EOS, Transactions, American Geophysical Union* 85:233.
- Engleberg, J., and L.L. Boyarsky. 1979. The noncybernetic nature of ecosystems. *American Naturalist* 114:317–324.
- Epstein, W.L., and A.M. Kligman. 1958. Treatment of warts with cantharidin. *American Medical Association Archives of Dermatology* 77:508–511.
- Erbilgin, N., D.L. Dahlsten, and P.-Y. Chen. 2004. Intraguild interactions between generalist predators and an introduced parasitoid of *Glycaspis brimblecombei* (Homoptera: Psylloidea). *Biological Control* 31:329–337.
- Ernsting, G., and D.C. van der Werf. 1988. Hunger, partial consumption of prey and prey size preference in a carabid beetle. *Ecological Entomology* 13:155–164.
- Erwin, T.L. 1995. Measuring arthropod diversity in the tropical forest canopy. In *Forest Canopies* (M.D. Lowman, and N.M. Nadkarni, Eds.), pp. 109–127. Academic Press, San Diego, CA.
- Eshleman, K.N., R.P. Morgan, II, J.R. Webb, F.A. Deviney, and J.N. Galloway. 1998. Temporal patterns of nitrogen leakage from mid-Appalachian forested watersheds: role of insect defoliation. *Water Resources Research* 34:2005–2116.
- Esper, J., U. Büntgen, D.C. Frank, D. Nievergelt, and A. Liebhold. 2007. 1200 years of regular outbreaks in alpine insects. *Proceedings of the Royal Society B* 274:671–679.
- Espirito-Santo, M.M., F.S. Neves, F.R. Andrade-Neto, and G.W. Fernandes. 2007. Plant architecture and meristem dynamics as the mechanisms determining the diversity of gall-inducing insects. *Oecologia* 153:353–364.
- Evans, E.W. 1988. Community dynamics of prairie grasshoppers subjected to periodic fire: predictable trajectories or random walks in time? *Oikos* 52:283–292.
- Evans, W.G. 1966. Perception of infrared radiation from forest fires by *Melanophila acuminata* de Geer (Buprestidae, Coleoptera). *Ecology* 47:1061–1065.
- Ewel, J.J. 1986. Designing agricultural ecosystems for the humid tropics. *Annual Review of Ecology and Systematics* 17:245–271.
- Ewel, J.J., and F.E. Putz. 2004. A place for alien species in ecosystem management. *Frontiers in Ecology and the Environment* 2:354–360.
- Ewel, J.J., M.J. Mazzarino, and C.W. Berish. 1991. Tropical soil fertility changes under monocultures and successional communities of different structure. *Ecological Applications* 1:289–302.
- Ewers, R.M., and R.K. Didham. 2006. Continuous response functions for quantifying the strength of edge effects. *Journal of Applied Ecology* 43:527–536.
- Faeth, S.H., E.F. Connor, and D. Simberloff. 1981. Early leaf abscission: a neglected source of mortality for folivores. *American Naturalist* 117:409–415.
- Fagen, W.F. 1997. Omnivory as a stabilizing feature of natural communities. *American Naturalist* 150:554–567.
- Fagundes, M., F.S. Neves, and G.W. Fernandes. 2005. Direct and indirect interactions involving ants, insect herbivores, parasitoids, and the host plant *Baccharis dracunculifolia* (Asteraceae). *Ecological Entomology* 30:28–35.
- Fajer, E.D., M.D. Bowers, and F.A. Bazzaz. 1989. The effects of enriched carbon dioxide atmospheres on plant–insect herbivore interactions. *Science* 243:1198–1200.
- Fares, Y., P.J.H. Sharpe, and C.E. Magnusen. 1980. Pheromone dispersion in forests. *Journal of Theoretical Biology* 84:335–359.
- Fargo, W.S., T.L. Wagner, R.N. Coulson, J.D. Cover, T. McAudle, and T.D. Schowalter. 1982. Probability functions for components of the *Dendroctonus frontalis*-host tree population system and their potential use with population models. *Researches in Population Ecology* 24:123–131.
- Farmer, E.E., and C.A. Ryan. 1990. Interplant communication: airborne methyl jasmonate induces synthesis of proteinase inhibitors in plant leaves. *Proceedings of the National Academy of Sciences, USA* 87:7713–7716.
- Farnsworth, N.R. 1966. Biological and phytochemical screening of plants. *Journal of Pharmaceutical Sciences* 55:225–276.
- Farwig, N., K. Böhning-Gaese, and B. Bleher. 2006. Enhanced seed dispersal of *Prunus africana* in fragmented and disturbed forests? *Oecologia* 147:238–252.
- Fastie, C.L. 1995. Causes and ecosystem consequences of multiple pathways of primary succession at Glacier Bay, Alaska. *Ecology* 76:1899–1916.
- Feeley, K.J., and J.W. Terborgh. 2005. The effects of herbivore density on soil nutrients and tree growth in tropical forest fragments. *Ecology* 86:116–124.
- Feener, D.H. Jr., 1981. Competition between ant species: outcome controlled by parasitic flies. *Science* 214:815–817.
- Feener, D.H., Jr., and B.V. Brown. 1992. Reduced foraging of *Solenopsis geminata* (Hymenoptera: Formicidae) in the presence of parasitic *Pseudacteon*

- spp. (Diptera: Phoridae). *Annals of the Entomological Society of America* 85:80–84.
- Feeny, P.P. 1969. Inhibitory effect of oak leaf tannins on the hydrolysis of proteins by trypsin. *Phytochemistry* 8:2119–2126.
- Feeny, P.P. 1970. Seasonal changes in oak leaf tannins and nutrients as a cause of spring feeding by winter moth caterpillars. *Ecology* 51:565–581.
- Fei, H., and G. Henderson. 1998. Effect of moisture and two nitrogen sources on nest site choice by alates and dealates of *Coptotermes formosanus* in the laboratory (Isoptera: Rhinotermitidae). *Sociobiology* 34:581–589.
- Feinsinger, P. 1983. Coevolution and pollination. In *Coevolution* (D.J. Futuyma, and M. Slatkin, Eds.), pp. 282–310. Sinauer Associates Inc, Sunderland, MA.
- Felton, G.W., and H. Eichenseer. 1999. Herbivore saliva and its effect on plant defense against herbivores and pathogens. In *Induced Plant Defenses Against Pathogens and Herbivores* (A.A. Agrawal, S. Tuzun, and E. Bent, Eds.), pp. 19–36. American Phytopathological Society, St. Paul, MN.
- Fernandez, D.S., and N. Fetcher. 1991. Changes in light availability following Hurricane Hugo in a subtropical montane forest in Puerto Rico. *Biotropica* 23:393–399.
- Ferrar, P. 1975. Disintegration of dung pads in north Queensland before the introduction of exotic dung beetles. *Australian Journal of Experimental Agriculture and Animal Husbandry* 15:325–329.
- Fewell, J.H., J.F. Harrison, J.R.B. Lighton, and M.D. Breed. 1996. Foraging energetics of the ant, *Paraponera clavata*. *Oecologia* 105:419–427.
- Feyereisen, R. 1999. Insect P450 enzymes. *Annual Review of Entomology* 44:507–533.
- Fielden, L.J., F.D. Duncan, Y. Rechav, and R.M. Crewe. 1994. Respiratory gas exchange in the tick *Amblyomma hebraeum* (Acari: Ixodidae). *Journal of Medical Entomology* 31:30–35.
- Fielding, D.J., and M.A. Brusven. 1993. Grasshopper (Orthoptera: Acrididae) community composition and ecological disturbances on southern Idaho rangeland. *Environmental Entomology* 22:71–81.
- Fielding, D.J., and M.A. Brusven. 1995. Ecological correlates between rangeland grasshopper (Orthoptera: Acrididae) and plant communities of southern Idaho. *Environmental Entomology* 24:1432–1441.
- Filip, V., R. Dirzo, J.M. Maass, and J. Sarukhán. 1995. Within- and among-year variation in the levels of herbivory on the foliage of trees from a Mexican tropical deciduous forest. *Biotropica* 27:78–86.
- Finch, V.C., and G.T. Trewartha. 1949. *Elements of Geography: Physical and Cultural*. McGraw-Hill, New York, NY.
- Fine, P.V.A., I. Mesones, and P.D. Coley. 2004. Herbivores promote habitat specialization by trees in Amazonian forests. *Science* 305:663–665.
- Finke, D.L., and R.F. Denno. 2002. Intraguild predation diminished in complex-structured vegetation: implications for prey suppression. *Ecology* 83:643–652.
- Finke, D.L., and R.F. Denno. 2006. Spatial refuge from intraguild predation: implications for prey suppression and trophic cascades. *Oecologia* 149:265–275.
- Fischer, D.G., S.C. Hart, B.J. Rehill, R.L. Lindroth, P. Keim, and T.G. Whitham. 2006. Do high-tannin leaves require more roots? *Oecologia* 149:668–675.
- Fischer, R.C., A. Richter, W. Wanek, and V. Mayer. 2002. Plants feed ants: food bodies for myrmecophytic *Piper* and their significance for the interaction with *Pheidole bicornis* ants. *Oecologia* 133:186–192.
- Fischer, R.C., W. Wanek, A. Richter, and V. Mayer. 2003. Do ants feed plants? A <sup>15</sup>N labelling study of nitrogen fluxes from ants to plants in the mutualism of *Pheidole* and *Piper*. *Journal of Ecology* 91:126–134.
- Fitzgerald, T.D. 1995. *The Tent Caterpillars*. Cornell Univ. Press, Ithaca.
- Flaherty, L., and D. Quiring. 2008. Plant module size and dose of gall induction stimulus influence gall induction and galler performance. *Oikos* 117:1601–1608.
- Flamm, R.O., P.E. Pulley, and R.N. Coulson. 1993. Colonization of disturbed trees by the southern pine beetle guild (Coleoptera: Scolytidae). *Environmental Entomology* 22:62–70.
- Fleishman, E., C. Ray, P. Sjögren-Gulve, C.L. Boggs, and D.D. Murphy. 2002. Assessing the roles of patch quality, area, and isolation in predicting metapopulation dynamics. *Conservation Biology* 16:706–716.
- Flinn, P.W., D.W. Hagstrum, W.E. Muir, and K. Sudayappa. 1992. Spatial model for simulating changes in temperature and insect population dynamics in stored grain. *Environmental Entomology* 21:1351–1356.
- Florence, L.Z., P.C. Johnson, and J.E. Coster. 1982. Behavioral and genetic diversity during dispersal: analysis of a polymorphic esterase locus in southern pine beetle, *Dendroctonus frontalis*. *Environmental Entomology* 11:1014–1018.
- Fogel, R., and K. Cromack, Jr. 1977. Effect of habitat and substrate quality on Douglas-fir litter decomposition in western Oregon. *Canadian Journal of Botany* 55:1632–1640.
- Foley, J.A., J.E. Kutzbach, M.T. Coe, and S. Levis. 1994. Feedbacks between climate and boreal forests during the Holocene epoch. *Nature* 371:52–54.
- Foley, J.A., M.H. Costa, C. Delire, N. Ramankutty, and P. Snyder. 2003a. Green surprise? How terrestrial ecosystems could affect earth's climate. *Frontiers in Ecology and the Environment* 1:38–44.
- Foley, J.A., M.T. Coe, M. Scheffer, and G. Wang. 2003b. Regime shifts in the Sahara and Sahel: interactions between ecological and climatic systems in northern Africa. *Ecosystems* 6:524–539.

- Foley, P. 1997. Extinction models for local populations. In *Metapopulation Biology: Ecology, Genetics, and Evolution* (I.A. Hanski, and M.E. Gilpin, Eds.), pp. 215–246. Academic Press, San Diego, CA.
- Folgarait, P.J., and L.E. Gilbert. 1999. Phorid parasitoids affect foraging activity of *Solenopsis richteri* under different availability of food in Argentina. *Ecological Entomology* 24:163–173.
- Folz, H.C., S.M. Wilder, M.H. Parsons, and A.L. Rypstra. 2006. Effects of predation risk on vertical habitat use and foraging of *Pardosa milvina*. *Ethology* 112:1152–1158.
- Fonseca, C.R. 1994. Herbivory and the long-lived leaves of an Amazonian ant-tree. *Journal of Ecology* 82:833–842.
- Fonseca, C.R., T. Fleck, and G.W. Fernandes. 2006. Processes driving ontogenetic succession of galls in a canopy tree. *Biotropica* 38:514–521.
- Fonseca, D.M., and D.D. Hart. 2001. Colonization history masks habitat preferences in local distributions of stream insects. *Ecology* 82:2897–2910.
- Fonte, S.J., and T.D. Schowalter. 2004. Decomposition of greenfall vs. senescent foliage in a tropical forest ecosystem in Puerto Rico. *Biotropica* 36:474–482.
- Fonte, S.J., and T.D. Schowalter. 2005. The influence of a neotropical herbivore (*Lamponius portoricensis*) on nutrient cycling and soil processes. *Oecologia* 146:423–431.
- Forbush, E.H., and C.H. Fernald. 1896. The Gypsy Moth. Massachusetts Board of Agriculture, Boston, MA.
- Ford, C.R., and J.M. Vose. 2007. *Tsuga canadensis* (L.) Carr. mortality will impact hydrologic processes in southern Appalachian forest ecosystems. *Ecological Applications* 17:1156–1167.
- Forkner, R.E., R.J. Marquis, and J.T. Lill. 2004. Feeny revisited: condensed tannins as anti-herbivore defenses in leaf-chewing herbivore communities of *Quercus*. *Ecological Entomology* 29:174–187.
- Forschler, B.T., and G. Henderson. 1995. Subterranean termite behavioral reaction to water and survival of inundation: implications for field populations. *Environmental Entomology* 24:1592–1597.
- Forup, M.L., K.S.E. Henson, P.G. Craze, and J. Memmott. 2008. The restoration of ecological networks: plant–pollinator networks on ancient and restored heathlands. *Journal of Applied Ecology* 45:742–752.
- Fowler, S.V., and J.H. Lawton. 1985. Rapidly induced defenses and talking trees: the devil's advocate position. *American Naturalist* 126:181–195.
- Fox, L.R. 1975a. Cannibalism in natural populations. *Annual Review of Ecology and Systematics* 6:87–106.
- Fox, L.R. 1975b. Some demographic consequences of food shortage for the predator, *Notonecta hoffmani*. *Ecology* 56:868–880.
- Fox, L.R., and B.J. Macauley. 1977. Insect grazing on Eucalyptus in response to variation in leaf tannins and nitrogen. *Oecologia* 29:145–162.
- Fox, L.R., and P.A. Morrow. 1981. Specialization: species property or local phenomenon? *Science* 211:887–893.
- Fox, L.R., and P.A. Morrow. 1983. Estimates of damage by herbivorous insects on *Eucalyptus* trees. *Australian Journal of Ecology* 8:139–147.
- Fox, L.R., and P.A. Morrow. 1992. Eucalypt responses to fertilization and reduced herbivory. *Oecologia* 89:214–222.
- Fox, L.R., S.P. Ribeiro, V.K. Brown, G.J. Masters, and I.P. Clarke. 1999. Direct and indirect effects of climate change on St. John's wort, *Hypericum perforatum* L. (Hypericaceae). *Oecologia* 120:113–122.
- Fox-Dobbs, K., D.F. Doak, A.K. Brody, and T.M. Palmer. 2010. Termites create spatial structure and govern ecosystem function by affecting N<sub>2</sub> fixation in an east African savanna. *Ecology* 91:1296–1307.
- Fradley, C., S. Johnson, and J. Li. 2007. Stream macroinvertebrate community responses as legacies of forest harvest at the H.J. Andrews Experimental Forest, Oregon. *Forest Science* 53:281–293.
- Fraenkel, G.S. 1953. The nutritional value of green plants for insects. In *Transactions of the IXth International Congress of Entomology* (W. Junk, Ed.), pp. 90–100. The Hague, The Netherlands.
- Fraenkel, G., and M. Blewett. 1946. Linoleic acid, vitamin E and other fat-soluble substances in the diet of certain insects, *Ephestria kuehniella*, *E. elutella*, *E. cautella*, and *Plodia interpunctella* (Lepidoptera). *Journal of Experimental Biology* 22:172–190.
- Frank, D.A., and S.J. McNaughton. 1991. Stability increases with diversity in plant communities: empirical evidence from the 1988 Yellowstone drought. *Oikos* 62:360–362.
- Frank, S.A. 1995. Mutual policing and repression of competition in the evolution of cooperative groups. *Nature* 377:520–522.
- Frankie, G.W., and L.E. Ehler. 1978. Ecology of insects in urban environments. *Annual Review of Entomology* 23:367–387.
- Franklin, J.F., F.J. Swanson, M.E. Harmon, D.A. Perry, T.A. Spies, V.H. Dale, A. McKee, W.K. Ferrell, J.E. Means, S.V. Gregory, J.D. Lattin, T.D. Schowalter, and D. Larsen. 1992. Effects of global climatic change on forests in northwestern North America. In *Global Warming and Biological Diversity* (R.L. Peters, and T.E. Lovejoy, Eds.), pp. 244–257. Yale University Press, New Haven, CT.
- French, J.R.J., and R.A. Roeper. 1972. Interactions of the ambrosia beetle, *Xyleborus dispar*, with its symbiotic fungus *Ambrosiella hartigii* (Fungi Imperfecti). *Canadian Entomologist* 104:1635–1641.
- Freyman, B.P., R. Buitenwerf, O. Desouza, and H. Olf. 2008. The importance of termites (Isoptera) for the recycling of herbivore dung in tropical ecosystems: a review. *European Journal of Entomology* 105:165–173.
- Fried, J.H., D.J. Levey, and J.A. Hogsette. 2005. Habitat corridors function as both drift fences and

- movement conduits for dispersing flies. *Oecologia* 143:645–651.
- Fritz, R.S. 1983. Ant protection of a host plant's defoliator: consequences of an ant–membracid mutualism. *Ecology* 64:789–797.
- Frost, C.J., and M.D. Hunter. 2004. Insect canopy herbivory and frass deposition affect soil nutrient dynamics and export in oak mesocosms. *Ecology* 85:3335–3347.
- Frost, C.J., and M.D. Hunter. 2007. Recycling of nitrogen in herbivore feces: plant recovery, herbivore assimilation, soil retention, and leaching losses. *Oecologia* 151:42–53.
- Frost, C.J., and M.D. Hunter. 2008a. Herbivore-induced shifts in carbon and nitrogen allocation in red oak seedlings. *New Phytologist* 178:835–845.
- Frost, C.J., and M.D. Hunter. 2008b. Insect herbivores and their frass affect *Quercus rubra* leaf quality and initial stages of subsequent decomposition. *Oikos* 117:13–22.
- Frouz, J., and P. Kindlmann. 2006. The role of sink to source re-colonisation in the population dynamics of insects living in unstable habitats: an example of terrestrial chironomids. *Oikos* 93:50–58.
- Frouz, J., R.J. Lobinske, and A. Ali. 2004. Influence of Chironomidae (Diptera) faecal pellet accumulation on lake sediment quality and larval abundance of pestiferous midge *Glyptotendipes paripes*. *Hydrobiologia* 518:169–177.
- Fry, S.N., and R. Wehner. 2002. Honey bees store landmarks in an egocentric frame of reference. *Journal of Comparative Physiology A* 187:1009–1016.
- Fu, X.-H., N. Ohba, Y.-Y. Wang, and C.-L. Lei. 2005. Bioluminescent courtship behavior of aquatic firefly *Luciola substriata* (Gorh.) (Coleoptera: Lampyridae) in China. *Acta Entomologica Sinica* 48:227–231 in Chinese with English summary.
- Fukami, T., S. Naeem, and D.A. Wardle. 2001. On similarity among local communities in biodiversity experiments. *Oikos* 95:340–348.
- Fukushima, J., Y. Kainoh, H. Honda, and J. Takabayashi. 2002. Learning of herbivore-induced and nonspecific plant volatiles by a parasitoid, *Cotesia kariyai*. *Journal of Chemical Ecology* 28:579–586.
- Furniss, R.L., and V.M. Carolin. 1977. Western Forest Insects. USDA Forest Service Misc. Publ 1339. USDA Forest Service, Washington, D.C..
- Futuyma, D.J., and S.S. Wasserman. 1980. Resource concentration and herbivory in oak forests. *Science* 210:920–922.
- Galatowitsch, M.L., and R.L. Mumme. 2004. Escape behavior of Neotropical homopterans in response to a flush–pursuit predator. *Biotropica* 36:586–595.
- Galeas, M.L., E.M. Klumper, L.E. Bennett, J.L. Freeman, B.C. Kondratieff, C.F. Quinn, and E.A.H. Pilon-Smits. 2008. Selenium hyperaccumulation reduces plant arthropod loads in the field. *New Phytologist* 177:715–724.
- Galizia, C.G., J. Kunze, A. Gumbert, A.-K. Borg-Karlson, S. Sachse, C. Markl, and R. Menzel. 2005. Relationship of visual and olfactory signal parameters in a food-deceptive flower mimicry system. *Behavioral Ecology* 16:159–168.
- Gandar, M.V. 1982. The dynamics and trophic ecology of grasshoppers (Acridoidea) in a South African savanna. *Oecologia* 54:370–378.
- Gandhi, K.J.K., D.W. Gilmore, S.A. Katovich, W.J. Mattson, S.R. Spence, and S.J. Seybold. 2007. Physical effects of weather events on the abundance and diversity of insects in North American forests. *Environmental Reviews* 15:113–152.
- Gandhi, K.J.K., J.R. Spence, D.W. Langor, L.E. Morgantini, and K.J. Cryer. 2004. Harvest retention patches are insufficient as stand analogues of fire residuals for litter-dwelling beetles in northern coniferous forests. *Canadian Journal of Forest Research* 34:1319–1331.
- Gange, A.C., and V.K. Brown. 1989. Insect herbivory affects size variability in plant populations. *Oikos* 56:351–356.
- Gange, A.C., E. Bower, and V.K. Brown. 1999. Positive effects of an arbuscular mycorrhizal fungus on aphid life history traits. *Oecologia* 120:123–131.
- Ganio, L.M., C.E. Torgersen, and R.E. Gresswell. 2005. A geostatistical approach for describing spatial pattern in stream networks. *Frontiers in Ecology and the Environment* 3:138–144.
- Gannes, L.Z., D.M. O'Brien, and C.M. del Rio. 1997. Stable isotopes in animal ecology: assumptions, caveats, and a call for more laboratory experiments. *Ecology* 78:1271–1276.
- Gara, R.I., D.R. Geiszler, and W.R. Littke. 1984. Primary attraction of the mountain pine beetle to lodgepole pine in Oregon. *Annals of the Entomological Society of America* 77:333–334.
- Gardiner, B., B. Marshall, A. Achim, R. Belcher, and C. Wood. 2005. The stability of different silvicultural systems: a wind-tunnel investigation. *Forestry* 78:471–484.
- Gardner, K.T., and D.C. Thompson. 1998. Influence of avian predation on a grasshopper (Orthoptera: Acrididae) assemblage that feeds on threadleaf snakeweed. *Environmental Entomology* 27:110–116.
- Garrett, K.A., and C.C. Mundt. 1999. Epidemiology in mixed host populations. *Phytopathology* 89:984–990.
- Garrettson, M., J.F. Stetzel, B.S. Halpern, D.J. Hearn, B.T. Lucey, and M.J. McKone. 1998. Diveristy and abundance of understorey plants on active and abandoned nests of leaf-cutting ants (*Atta cephalotes*) in a Costa Rican rain forest. *Journal of Tropical Ecology* 14:17–26.
- Garrison, R.W., and M.R. Willig. 1996. Arboreal invertebrates. In *The Food Web of a Tropical Rain Forest* (D.P. Reagan, and R.B. Waide, Eds.), pp. 183–245. University of Chicago Press, Chicago, IL.

- Gascoigne, J., L. Berec, S. Gregory, and F. Courchamp. 2009. Dangerously few liaisons: a review of mate-finding Allee effects. *Population Ecology* 51:355–372.
- Gaston, K.J. 2000. Global patterns in biodiversity. *Nature* 405:220–227.
- Gate, I.M., S. McNeill, and M.R. Ashmore. 1995. Effects of air pollution on the searching behaviour of an insect parasitoid. *Water, Air and Soil Pollution* 85:1425–1430.
- Gatto, B., A. Zocca, A. Battisti, M.J. Barrento, M. Branco, and M.R. Paiva. 2009. Economic assessment of managing processionary moth in pine Forests: a case-study in Portugal. *Journal of Environmental Management* 90:683–691.
- Gear, A.J., and B. Huntley. 1991. Rapid changes in the range limits of Scots pine 4000 years ago. *Science* 251:544–547.
- Gehring, C.A., and T.G. Whitham. 1991. Herbivore-driven mycorrhizal mutualism in insect-susceptible pinyon pine. *Nature* 353:556–557.
- Gehring, C.A., and T.G. Whitham. 1995. Duration of herbivore removal and environmental stress affect the ectomycorrhizae of pinyon pine. *Ecology* 76:2118–2123.
- Genersch, E. 2010. Honey bee pathology: current threats to honey bees and beekeeping. *Applied Microbiology and Biotechnology* 87:87–97.
- Gering, J.C., T.O. Crist, and J.A. Veech. 2003. Additive partitioning of species diversity across multiple spatial scales: implications for regional conservation of biodiversity. *Conservation Biology* 17:488–499.
- Gering, J.C., K.A. DeRennaux, and T.O. Crist. 2007. Scale-dependence of effective specialization: its analysis and implications for estimation of global insect species richness. *Diversity and Distributions* 13:115–125.
- Ghazoul, J., and M. McLeish. 2001. Reproductive ecology of tropical forest trees in logged and fragmented habitats in Thailand and Costa Rica. *Plant Ecology* 153:335–345.
- Gibbs, A.G. 2002. Lipid melting and cuticular permeability: new insights into an old problem. *Journal of Insect Physiology* 48:391–400.
- Gibbs, A.G. 2002. Water balance in desert *Drosophila*: lessons from non-charismatic microfauna. *Comparative Biochemistry and Physiology A* 133:781–789.
- Gibbs, A.G., and T.A. Markow. 2001. Effects of age on water balance in *Drosophila* species. *Physiological and Biochemical Zoology* 74:520–530.
- Gibbs, A.G., and L.M. Matzkin. 2001. Evolution of water balance in the genus *Drosophila*. *Journal of Experimental Biology* 204:2331–2338.
- Gibbs, A.G., F. Fukuzato, and L.M. Matzkin. 2003. Evolution of water conservation mechanisms in *Drosophila*. *Journal of Experimental Biology* 206:1183–1192.
- Gibson, D.J., C.C. Freeman, and L.C. Hulbert. 1990. Effects of small mammal and invertebrate herbivory on plant species richness and abundance in tallgrass prairie. *Oecologia* 84:169–175.
- Gibson, R.H., I.L. Nelson, G.W. Hopkins, B.J. Hamlett, and J. Memmott. 2006. Pollinator webs, plant communities and the conservation of rare plants: arable weeds as a case study. *Journal of Applied Ecology* 43:246–257.
- Gibson, R.W., and J.A. Pickett. 1983. Wild potato repels aphids by release of aphid alarm pheromone. *Nature* 302:608–609.
- Giebultowicz, J.M. 2000. Molecular mechanism and cellular distribution of insect circadian clocks. *Annual Review of Entomology* 45:769–793.
- Giebultowicz, J.M., and D.L. Denlinger. 1986. Role of the brain and ring gland in regulation of pupal diapause in the flesh fly *Sarcophaga crassipalpis*. *Journal of Insect Physiology* 32:161–166.
- Gilbert, M., and J.-C. Grégoire. 2003. Site condition and predation influence a bark beetle's success: a spatially realistic approach. *Agricultural and Forest Entomology* 5:87–96.
- Gillette, N.D., N. Erbilgin, J.N. Webster, L. Pederson, S.R. Mori, J.D. Stein, D.R. Owen, K.M. Bischel, and D.L. Wood. 2009. Aerially applied verbenone-releasing laminated flakes protect *Pinus contorta* stands from attack by *Dendroctonus ponderosae* in California and Idaho. *Forest Ecology and Management* 257:1405–1412.
- Gist, C.S., and D.A. Crossley, Jr. 1975. The litter arthropod community in a southern Appalachian hardwood forest: numbers, biomass and mineral element content. *American Midland Naturalist* 93:107–122.
- Gleason, H.A. 1917. The structure and development of the plant association. *Bulletin of the Torrey Botanical Club* 44:463–481.
- Gleason, H.A. 1926. The individualistic concept of the plant association. *Bulletin of the Torrey Botanical Club* 53:7–26.
- Gleason, H.A. 1927. Further views on the succession-concept. *Ecology* 8:299–326.
- Glenn-Lewin, D.C., R.K. Peet, and T.T. Veblen. 1992. *Plant Succession: Theory and Prediction*. Chapman and Hall, New York, NY.
- Gliessman, S.R. 2007. *Agroecology: the Ecology of Sustainable Food Systems*, 2<sup>nd</sup> Ed.. CRC Press, Boca Raton, FL.
- Glynn, C., D.A. Herms, M. Egawa, R. Hansen, and W.J. Mattson. 2003. Effects of nutrient availability on biomass allocation as well as constitutive and rapid induced herbivore resistance in poplar. *Oikos* 101:385–397.
- Glynn, C., D.A. Herms, C.M. Orians, R. Hansen, and W.J. Mattson. 2007. Testing the growth-differentiation balance hypothesis: dynamic responses of willows to nutrient availability. *New Phytologist* 176:623–634.

- Godfray, H.C.J. 1994. *Parasitoids: Behavioral and Evolutionary Ecology*. Princeton University Press, Princeton, NJ.
- Goff, M.L. 2000. *A Fly for the Prosecution: How Insect Evidence Helps Solve Crimes*. Harvard University Press, Cambridge, MA.
- Goh, B.S. 1979. Stability of models of mutualism. *American Naturalist* 113:261–275.
- Golden, D.M., and T.O. Crist. 1999. Experimental effects of habitat fragmentation on old-field canopy insects: community, guild and species responses. *Oecologia* 118:371–380.
- Goldwasser, L., and J. Roughgarden. 1997. Sampling effects and the estimation of food-web properties. *Ecology* 78:41–54.
- Golley, F.B. 1968. Secondary productivity in terrestrial communities. *American Zoologist* 8:53–59.
- Golley, F.B. 1977. Insects as regulators of forest nutrient cycling. *Tropical Ecology* 18:116–123.
- Golley, F.B. 1993. *A History of the Ecosystem Concept in Ecology*. Yale University Press, New Haven, CT.
- Gong, Z.-F., S.-Z. Xia, L. Liu, C.-H. Feng, and A.-K. Guo. 1998. Operant visual learning and memory in *Drosophila* mutants *dunce*, *amnesiac* and *radish*. *Journal of Insect Physiology* 44:1149–1158.
- González, G., and T.R. Seastedt. 2001. Soil fauna and plant litter decomposition in tropical and subalpine forests. *Ecology* 82:955–964.
- Gonzalez, M., and M. Loreau. 2009. The causes and consequences of compensatory dynamics in ecological communities. *Annual Review of Ecology, Evolution and Systematics* 40:393–414.
- Goodisman, M.A.D., and D.A. Hahn. 2004. Colony genetic structure of the ant *Camponotus ocreatus* (Hymenoptera: Formicidae). *Sociobiology* 44:21–33.
- Gorb, E., and S. Gorb. 2003. *Seed Dispersal by Ants in a Deciduous Forest Ecosystem: Mechanisms, Strategies, Adaptations*. Kluwer Academic Publishers, Dordrecht, The Netherlands.
- Gordon, D.M., and A.W. Kulig. 1996. Founding, foraging, and fighting: colony size and the spatial distribution of harvester ant nests. *Ecology* 77:2393–2409.
- Goto, S.G., and D.L. Denlinger. 2002. Short-day and long-day expression patterns of genes involved in the flesh fly clock mechanism: *period*, *timeless*, *cycle* and *cryptochrome*. *Journal of Insect Physiology* 48:803–816.
- Gould, F. 1998. Sustainability of transgenic insecticidal cultivars. *Annual Review of Entomology* 43:701–726.
- Gould, J.L. 1985. How bees remember flower shapes. *Science* 227:1492–1494.
- Gould, J.L. 1986. The locale map of honey bees: do insects have cognitive maps? *Science* 232:861–863.
- Gould, J.L., and W.F. Towne. 1988. Honey bee learning. *Advances in Insect Physiology* 20:55–86.
- Gould, J.L., J.L. Kirschvink, and K.S. Deffeyes. 1978. Bees have magnetic remanence. *Science* 201:1026–1028.
- Gould, S.J., and E.S. Vrba. 1982. Exaptation—a missing term in the science of form. *Paleobiology* 8:4–15.
- Goverde, M., M.G.A. van der Heijden, A. Wiemken, I.R. Sanders, and A. Erhardt. 2000. Arbuscular mycorrhizal fungi influence life history traits of a lepidopteran herbivore. *Oecologia* 125:362–369.
- Goyer, R.A., M.R. Wagner, and T.D. Schowalter. 1998. Current and proposed technologies for bark beetle management. *Journal of Forestry* 96(12):29–33.
- Goyer, R.A., G.J. Lenhard, and B.L. Strom. 2004. The influence of silhouette color and orientation on arrival and emergence of *Ips* pine engravers and their predators in loblolly pine. *Forest Ecology and Management* 191:147–155.
- Grace, J.K., and N.-Y. Su. 2001. Evidence supporting the use of termite baiting systems for long-term structural protection. *Sociobiology* 37:301–310.
- Grace, J.R. 1986. The influence of gypsy moth on the composition and nutrient content of litter fall in a Pennsylvania oak forest. *Forest Science* 32:855–870.
- Grant, G.G., and W.E. Miller. 1995. Larval images on lepidopteran wings—an unrecognized defense mechanism? *American Entomologist* 41:44–48.
- Gratton, C., and R.F. Denno. 2006. Arthropod food web restoration following removal of an invasive wetland plant. *Ecological Applications* 16:622–631.
- Gratton, C., J. Donaldson, and M.J. Vander Zanden. 2008. Ecosystem linkages between lakes and the surrounding terrestrial landscape in Iceland. *Ecosystems* 11:764–774.
- Greathouse, E.A., C.M. Pringle, W.H. McDowell, and J.G. Holmquist. 2006. Indirect upstream effects of dams: consequences of migratory consumer extirpation in Puerto Rico. *Ecological Applications* 16:339–352.
- Greenbank, D.O. 1957. The role of climate and dispersal in the initiation of outbreaks of the spruce budworm in New Brunswick. I. The role of climate. *Canadian Journal of Zoology* 34:453–476.
- Greenbank, D.O. 1963. The development of the outbreak. In *The Dynamics of Epidemic Spruce Budworm Populations*, 31. (Morris R.F., Ed.), pp. 19–23. Memoirs of the Entomological Society of Canada.
- Greenfield, A.B. 2005. *A Perfect Red: Empire, Espionage, and the Quest for the Color of Desire*. Harper Collins Publ, New York, NY.
- Gressitt, J.L., G.A. Samuelson, and D.H. Vitt. 1968. Moss growing on living Papuan moss-forest weevils. *Nature* 217:765–767.
- Gressitt, J.L., J. Sedlacek, and J.J.H. Szent-Ivany. 1965. Flora and fauna on backs of large Papuan moss-forest weevils. *Science* 150:1833–1835.
- Gribko, L.S., A.M. Liebhold, and M.E. Hohn. 1995. Model to predict gypsy moth (Lepidoptera: Lyman-

- triidae) defoliation using kriging and logistic regression. *Environmental Entomology* 24:529–537.
- Grier, C.C., and D.J. Vogt. 1990. Effects of aphid honeydew on soil nitrogen availability and net primary production in an *Alnus rubra* plantation in western Washington. *Oikos* 57:114–118.
- Gries, R., P.W. Schaefer, T. Gotoh, S. Takács, and G. Gries. 2009. Spacing of traps baited with species-specific *Lymantria* pheromones to prevent interference by antagonistic components. *Canadian Entomologist* 141:145–152.
- Grilli, M.P., and D.E. Gorla. 1997. The spatio-temporal pattern of *Delphacodes kuscheli* (Homoptera: Delphacidae) abundance in central Argentina. *Bulletin of Entomological Research* 87:45–53.
- Grimbacher, P.S., and N.E. Stork. 2009. How do beetle assemblages respond to cyclonic disturbance of a fragmented tropical rainforest landscape? *Oecologia* 161:591–599.
- Grime, J.P. 1977. Evidence for the existence of three primary strategies in plants and its relevance to ecological and evolutionary theory. *American Naturalist* 111:1169–1194.
- Grime, J.P. 1997. Biodiversity and ecosystem function: the debate deepens. *Science* 277:1260–1261.
- Grime, J.P., J.H.C. Cornelissen, K. Thompson, and J.G. Hodgson. 1996. Evidence of a causal connection between anti-herbivore defense and the decomposition rate of leaves. *Oikos* 77:489–494.
- Groot, A.T., J.L. Horovitz, J. Hamilton, R.G. Santangelo, C. Schal, and F. Gould. 2006. Experimental evidence for interspecific directional selection on moth pheromone communication. *Proceedings of the National Academy of Sciences, USA* 103:5858–5863.
- Gross, I., P. Georgel, C. Kappler, J.-M. Reichhart, and J.A. Hoffmann. 1996. *Drosophila* immunity: a comparative analysis of the Rel proteins dorsal and Dif in the induction of the genes encoding dipterin and cecropin. *Nucleic Acids Research* 24:1238–1245.
- Grove, S.J. 2002. Saproxylic insect ecology and the sustainable management of forests. *Annual Review of Ecology and Systematics* 33:1–23.
- Gudger, E.W. 1925. Stitching wounds with the mandibles of ants and beetles. *Journal of the American Medical Association* 84:1861–1864.
- Guillot, F.S., D.R. Ring, A.R. Lax, A. Morgan, K. Brown, C. Riegel, and D. Boykin. 2010. Area-wide management of the Formosan subterranean termite, *Coptotermes formosanus* Shiraki (Isoptera: Rhinotermitidae), in the New Orleans French Quarter. *Sociobiology* 55:311–338.
- Gumbert, A., J. Kunze, and L. Chittka. 1999. Floral colour diversity in plant communities, bee colour space and a null model. *Proceedings of the Royal Society of London B* 266:1711–1716.
- Gunn, D.L., and H.D. Brown. 1979. The development of aircraft attack on locust swarms in Africa since 1945 and the start of operational research on control systems. *Philosophical Transactions of the Royal Society of London, Series B* 287:251–263.
- Gunn, D.L., F.C. Perry, W.G. Seymour, T.M. Telford, E.N. Wright, and D. Yeo. 1948. Behaviour of the desert locust (*Schistocerca gregaria* Forskål) in Kenya in relation to aircraft spraying. *Anti-locust Bulletin* 3.
- Guo, H., Q. Hu, and T. Jiang. 2008. Annual and seasonal streamflow responses to climate and land-cover changes in the Poyang Lake Basin, China. *Journal of Hydrology* 355:106–122.
- Guo, Q. 1998. Microhabitat differentiation in Chihuahuan Desert plant communities. *Plant Ecology* 139:71–80.
- Gutierrez, A.P. 1986. Analysis of the interactions of host plant resistance, phytophagous and entomophagous species. In *Interactions of Plant Resistance and Parasitoids and Predators of Insects* (D.J. Boethel, and R.D. Eikenbary, Eds.), pp. 198–215. Ellis Horwood Ltd, Chichester, UK.
- Gutierrez, A.P. 1996. Applied Population Ecology: a Supply–demand Approach. John Wiley & Sons, Inc, New York, NY.
- Gutiérrez-Ibáñez, C., C.A. Villagra, and H.M. Niemeyer. 2007. Pre-pupation behaviour of the aphid parasitoid *Aphidius ervi* (Haliday) and its consequences for pre-imaginal learning. *Naturwissenschaften* 94:595–600.
- Gutschick, V.P. 1999. Biotic and abiotic consequences of differences in leaf structure. *New Phytologist* 143:3–18.
- Gutschick, V.P., and H. BassiriRad. 2010. Biological extreme events: a research framework. *EOS, Transactions, American Geophysical Union* 91:85–86.
- Habermann, E. 1972. Bee and wasp venoms. *Science* 177:314–322.
- Hackstein, J.H.P., and C.K. Stumm. 1994. Methane production in terrestrial arthropods. *Proceedings of the National Academy of Sciences, USA* 91:5441–5445.
- Haddad, N.M. 1999. Corridor and distance effects on interpatch movements: a landscape experiment with butterflies. *Ecological Applications* 9:612–622.
- Haddad, N. 2000. Corridor length and patch colonization by a butterfly, *Junonia coenia*. *Conservation Biology* 14:738–745.
- Haddad, N.M., and K.A. Baum. 1999. An experimental test of corridor effects on butterfly densities. *Ecological Applications* 9:623–633.
- Haddad, N.M., D.R. Browne, A. Cunningham, B.J. Danielson, D.J. Levey, S. Sargent, and T. Spira. 2003. Corridor use by diverse taxa. *Ecology* 84:609–615.
- Haddad, N.M., M. Holyoak, T.M. Mata, K.F. Davies, B.A. Melbourne, and K. Preston. 2008. Species' traits predict the effects of disturbance and productivity on diversity. *Ecology Letters* 11:348–356.
- Hadley, K.S., and T.T. Veblen. 1993. Stand response to western spruce budworm and Douglas-fir bark



- beetle outbreaks, Colorado Front Range. *Canadian Journal of Forest Research* 23:479–491.
- Hadley, N.F. 1994. Water Relations of Terrestrial Arthropods. Academic Press, San Diego, CA.
- Hagen, K.S., and J.M. Franz. 1973. A history of biological control. In *History of Entomology* (R.F. Smith, T.E. Mittler, and C.N. Smith, Eds.), pp. 433–476. Annual Reviews Inc, Palo Alto, CA.
- Haggerty, S.M., D.P. Batzer, and C.R. Jackson. 2002. Macroinvertebrate assemblages in perennial headwater streams of the coastal mountain range of Washington, U.S.A.. *Hydrobiologia* 479:143–154.
- Haggerty, S.M., D.P. Batzer, and C.R. Jackson. 2004. Macroinvertebrate response to logging in coastal headwater streams in Washington, U.S.A.. *Canadian Journal of Fisheries and Aquatic Science* 61:529–537.
- Haglund, B.M. 1980. Proline and valine—cues which stimulate grasshopper herbivory during drought stress? *Nature* 288:697–698.
- Haimi, J., and V. Huhta. 1990. Effects of earthworms on decomposition processes in raw humus forest soil: a microcosm study. *Biology and fertility of Soils* 10:178–183.
- Hain, F.P. 1980. Sampling and predicting population trends. In *The Southern Pine Beetle* (R.C. Thatcher, J.L. Searcy, J.E. Coster, and G.D. Hertel, Eds.), pp. 107–135. USDA Forest Service Tech. Bull. 1631. USDA Forest Service, Washington, DC.
- Haines, B.L. 1978. Element and energy flows through colonies of the leaf-cutting ant, *Atta columbica*, in Panama. *Biotropica* 10:270–277.
- Hairston, N.G., F.E. Smith, and L.B. Slobodkin. 1960. Community structure, population control, and competition. *American Naturalist* 94:421–425.
- Hajek, A.E., and R.J. St. Leger. 1994. Interactions between fungal pathogens and insect hosts. *Annual Review of Entomology* 39:293–322.
- Halaj, J., D.W. Ross, and A.R. Moldenke. 1997. Negative effects of ant foraging on spiders in Douglas-fir canopies. *Oecologia* 109:313–322.
- Haldane, J.B.S. 1932. *The Causes of Evolution*. Harper and Brothers, New York, NY.
- Hall, M.C., P. Stiling, D.C. Moon, B.G. Drake, and M.D. Hunter. 2005. Effects of elevated CO<sub>2</sub> on foliar quality and herbivore damage in a scrub oak ecosystem. *Journal of Chemical Ecology* 31:267–286.
- Hall, S.R. 2009. Stoichiometrically-explicit food webs: feedbacks between resource supply, elemental constraints, and species diversity. *Annual Review of Ecology, Evolution and Systematics* 40:503–528.
- Hambäck, P.A., J. Petterson, and L. Ericson. 2003. Are associational refuges species-specific? *Functional Ecology* 17:87–93.
- Hamilton, G.R., and T.F. Baskett. 2000. History of anesthesia: in the arms of Morpheus: the development of morphine for postoperative pain relief. *Canadian Journal of Anesthesiology* 47:367–374.
- Hamilton, W.D. 1964. The genetic evolution of social behavior. I. and II. *Journal of Theoretical Biology* 7:1–52.
- Hance, T., J. van Baaren, P. Vernon, and G. Boivin. 2007. Impact of extreme temperatures on parasitoids in a climate change perspective. *Annual Review of Entomology* 52:107–126.
- Hanewinkel, M., J. Breidenbach, T. Neeff, and E. Kublin. 2008. Seventy-seven years of natural disturbances in a mountain forest area—the influence of storm, snow, and insect damage analysed with a long-term time series. *Canadian Journal of Forest Research* 38:2249–2261.
- Hansen, D.M., and C.B. Müller. 2009. Invasive ants disrupt gecko pollination and seed dispersal of the endangered plant *Roussea simplex* in Mauritius. *Biotropica* 41:202–208.
- Hansen Jesse, L.C., and J.J. Obrycki. 2000. Field deposition of Bt transgenic corn pollen: lethal effects on the monarch butterfly. *Oecologia* 125:241–248.
- Hanski, I. 1989. Metapopulation dynamics: does it help to have more of the same? *Trends in Ecology and Evolution* 4:113–114.
- Hanski, I. 1997. Metapopulation dynamics: from concepts and observations to predictive models. In *Metapopulation Biology: Ecology, Genetics and Evolution* (I.A. Hanski, and M.E. Gilpin, Eds.), pp. 69–91. Academic Press, San Diego, CA.
- Hanski, I.A., and M.E., Gilpin (Eds.). 1997. *Metapopulation Biology: Ecology, Genetics and Evolution*. Academic Press, San Diego, CA.
- Hanski, I., and D. Simberloff. 1997. The metapopulation approach, its history, conceptual domain, and application to conservation. In *Metapopulation Biology: Ecology, Genetics and Evolution* (I.A. Hanski, and M.E. Gilpin, Eds.), pp. 5–26. Academic Press, San Diego, CA.
- Hanski, I., and M.C. Singer. 2001. Extinction–colonization dynamics and host–plant choice in butterfly metapopulations. *American Naturalist* 158:341–353.
- Hanson, B., S.D. Lindblom, M.L. Loeffler, and E.A.H. Pilon-Smits. 2004. Selenium protects plants from phloem-feeding aphids due to both deterrence and toxicity. *New Phytologist* 162:655–662.
- Hanula, J.L., and D.D. Wade. 2003. Influence of long-term dormant-season burning and fire exclusion on ground-dwelling arthropod populations in longleaf pine flatwoods ecosystems. *Forest Ecology and Management* 175:163–184.
- Harborne, J.B. 1994. *Introduction to Ecological Biochemistry*, 4<sup>th</sup> Ed.. Academic Press, London, UK.
- Hardee, D.D., and F.A. Harris. 2003. Eradicating the boll weevil (Coleoptera: Curculionidae): a clash between a highly successful insect, good scientific achievement, and differing agricultural philosophies. *American Entomologist* 49:82–97.
- Hardie, J. 2001. Photoperiodism and seasonality in aphids. In *Insect Timing: Circadian Rhythmicity to*

- Seasonality* (D.L. Denlinger, J.M. Giebultowicz, and D.S. Saunders, Eds.), pp. 85–94. Elsevier, Amsterdam, The Netherlands.
- Harding, J.S., E.F. Benfield, P.V. Bolstad, G.S. Helfman, and E.B.D. Jones, III. 1998. Stream biodiversity: the ghost of land use past. *Proceedings of the National Academy of Sciences, USA* 95:14843–14847.
- Hare, J.F., and T.M. Alloway. 2001. Prudent *Protomognathus* and despotic *Leptothorax duloticus*: differential costs of ant slavery. *Proceedings of the National Academy of Sciences* 98:12093–12096.
- Hargrove, W.W. 1988. A photographic technique for tracking herbivory on individual leaves through time. *Ecological Entomology* 13:359–363.
- Harmon, M.E., J.F. Franklin, F.J. Swanson, P. Sollins, S.V. Gregory, J.D. Lattin, N.H. Anderson, S.P. Cline, N.G. Aumen, J.R. Sedell, G.W. Lienkaemper, K. Cromack, Jr., and K.W. Cummins. 1986. Ecology of coarse woody debris in temperate ecosystems. *Advances in Ecological Research* 15:133–302.
- Harmon, M.E., J. Sexton, B.A. Caldwell, and S.E. Carpenter. 1994. Fungal sporocarp mediated losses of Ca, Fe, K, Mg, Mn, N, P, and Zn from conifer logs in the early stages of decomposition. *Canadian Journal of Forest Research* 24:1883–1893.
- Harrel, R.C. 1985. Effects of a crude oil spill on water quality and macrobenthos of a southeast Texas stream. *Hydrobiologia* 124:223–228.
- Harris, L.D. 1984. *The Fragmented Forest*. University of Chicago Press, Chicago, IL.
- Harris, T.W. 1841. *Treatise on some of the Insects Injurious to Vegetation*. William White, Boston MA.
- Harrison, S. 1994. Resources and dispersal as factors limiting a population of the tussock moth (*Orgyia vetusta*), a flightless defoliator. *Oecologia* 99:27–34.
- Harrison, S., and N. Cappuccino. 1995. Using density-manipulation experiments to study population regulation. In *Population Dynamics: New Approaches and Synthesis* (N. Cappuccino, and P.W. Price, Eds.), pp. 131–147. Academic Press, San Diego, CA.
- Harrison, S., and R. Karban. 1986. Effects of an early-season folivorous moth on the success of a later-season species, mediated by a change in the quality of the shared host, *Lupinus arboreus* Sims. *Oecologia* 69:354–359.
- Harrison, S., and A.D. Taylor. 1997. Empirical evidence for metapopulation dynamics. In *Metapopulation Biology: Ecology, Genetics and Evolution* (I.A. Hanski, and M.E. Gilpin, Eds.), pp. 27–42. Academic Press, San Diego, CA.
- Hart, D.D. 1992. Community organization in streams: the importance of species interactions, physical factors, and chance. *Oecologia* 91:220–228.
- Hartley, S.E. 1998. The chemical composition of plant galls: are levels of nutrients and secondary plant compounds controlled by the gall-former? *Oecologia* 113:492–501.
- Hartley, S.E., and A.C. Gange. 2009. Impacts of plant symbiotic fungi on insect herbivores: mutualism in a multitrophic context. *Annual Review of Entomology* 54:323–342.
- Hassall, M., A. Hawthorne, M. Maudsley, P. White, and C. Cardwell. 1992. Effects of headland management on invertebrate communities in cereal fields. *Agriculture, Ecosystems and Environment* 40:155–178.
- Hassell, M.P., and G.C. Varley. 1969. New inductive population model for insect parasites and its bearing on biological control. *Nature* 223:1133–1136.
- Hassell, M.P., H.N. Comins, and R.M. May. 1991. Spatial structure and chaos in insect population dynamics. *Nature* 353:255–258.
- Hatcher, P.E., P.G. Ayres, and N.D. Paul. 1995. The effect of natural and simulated insect herbivory, and leaf age, on the process of infection of *Rumex crispus* L. and *R. obtusifolius* L. by *Uromyces rumicis* (Schum.) Wint. *New Phytologist* 130:239–249.
- Hatcher, P.E., J. Moore, J.E. Taylor, G.W. Tinney, and N.D. Paul. 2004. Phytohormones and plant–herbivore–pathogen interactions: integrating the molecular with the ecological. *Ecology* 85:59–69.
- Hättenschwiler, S., and P. Gasser. 2005. Soil animals alter plant litter diversity effects on decomposition. *Proceedings of the National Academy of Sciences, USA* 102:1519–1524.
- Haukioja, E. 1990. Induction of defenses in trees. *Annual Review of Entomology* 36:25–42.
- Havens, K. 1992. Scale and structure in natural food webs. *Science* 257:1107–1109.
- Hawkins, B.A., F.S. Albuquerque, M.B. Araújo, J. Beck, L.M. Bini, F.J. Cabrero-Sañudo, I. Castro-Parga, J.A.F. Diniz-Filho, D. Ferrer-Castán, R. Field, J.F. Gómez, J. Hortal, J.T. Kerr, I.J. Kitching, J.L. León-Cortés, J.M. Lobo, D. Montoya, J.C. Moreno, M.Á. Olalla-Tárraga, J.G. Pausas, H. Qian, C. Rahbek, M.Á. Rodríguez, N.J. Sanders, and P. Williams. 2007. A global evaluation of metabolic theory as an explanation for terrestrial species richness gradients. *Ecology* 88:1877–1888.
- Hawkins, C.P., and J.A. MacMahon. 1989. Guilds: the multiple meanings of a concept. *Annual Review of Entomology* 34:423–451.
- Hawkins, C.P., R.H. Norris, J.N. Hogue, and J.W. Feminella. 2000. Development and evaluation of predictive models for measuring the biological integrity of streams. *Ecological Applications* 10:1456–1477.
- Hayes, J.L., B.L. Strom, L.M. Roton, and L.L. Ingram, Jr. 1994. Repellent properties of the host compound 4-allylanisole to the southern pine beetle. *Journal of Chemical Ecology* 20:1595–1615.
- Haynes, K.J., and J.T. Cronin. 2003. Matrix composition affects the spatial ecology of a prairie planthopper. *Ecology* 84:2856–2866.
- Hazlett, D.L. 1998. *Vascular Plant Species of the Pawnee National Grasslands*. USDA Forest Service Gen. Tech. Rpt. RM-GTR-17, USDA Forest Service, Rocky Mountain Exp. Stn, Ft. Collins, CO.

- He, F., and R.I. Alfaro. 1997. White pine weevil (Coleoptera: Curculionidae) attack on white spruce: spatial and temporal patterns. *Environmental Entomology* 26:888–895.
- He, F., and P. Legendre. 2002. Species diversity patterns derived from species-area models. *Ecology* 83:1185–1198.
- Heartsill-Scalley, T., F.N. Scatena, C. Estrada, W.H. McDowell, and A.E. Lugo. 2007. Disturbance and long-term patterns of rainfall and throughfall nutrient fluxes in a subtropical wet forest in Puerto Rico. *Journal of Hydrology* 333:472–485.
- Hedrick, P.W., and M.E. Gilpin. 1997. Genetic effective size of a metapopulation. In *Metapopulation Biology: Ecology, Genetics and Evolution* (I.A. Hanski, and M.E. Gilpin, Eds.), pp. 165–181. Academic Press, San Diego, CA.
- Heiermann, J., and S. Schütz. 2008. The effect of the tree species ratio of European beech (*Fagus sylvatica* L.) and Norway spruce (*Picea abies* (L.) Karst.) on polyphagous and monophagous pest species—*Lymantria monacha* L. and *Calliteara pudibunda* L. (Lepidoptera: Lymantriidae) as an example. *Forest Ecology and Management* 255:1161–1166.
- Heinrich, B. 1974. Thermoregulation in endothermic insects. *Science* 185:747–756.
- Heinrich, B. 1979. Bumblebee Economics. Harvard University Press, Cambridge, MA.
- Heinrich, B. 1981. Insect Thermoregulation. Wiley, New York, NY.
- Heinrich, B. 1993. The Hot-blooded Insects: Strategies and Mechanisms of Thermoregulation. Harvard University Press, Cambridge, MA.
- Heinrich, B., and P. Raven. 1972. Energetics and polination ecology. *Science* 176:597–602.
- Heithaus, E.R. 1979. Flower-feeding specialization in wild bee and wasp communities in seasonal neotropical habitats. *Oecologia* 42:179–194.
- Heithaus, E.R. 1981. Seed predation by rodents on three ant-dispersed plants. *Ecology* 62:136–145.
- Heliövaara, K. 1986. Occurrence of *Petrova resinella* (Lepidoptera: Tortricidae) in a gradient of industrial air pollutants. *Silva Fennica* 20:83–90.
- Heliövaara, K., and R. Väisänen. 1986. Industrial air pollution and the pine bark bug, *Aradus cinnamomeus* Panz. (Het. Aradidae). *Zeitschrift für angewandte Entomologie* 101:469–478.
- Heliövaara, K., and R. Väisänen. 1993. Insects and Pollution. CRC Press, Boca Raton, FL.
- Helson, J.E., T.L. Capson, T. Johns, A. Aiello, and D.M. Windsor. 2009. Ecological and evolutionary bioprospecting: using aposematic insects as guides to rainforest plants active against disease. *Frontiers in Ecology and the Environment* 7:130–134.
- Hemmann, D.J., J.D. Allison, and K.F. Haynes. 2008. Trade-off between sensitivity and specificity in the cabbage looper response to sex pheromone. *Journal of Chemical Ecology* 34:1476–1486.
- Hendrix, P.F., D.A. Crossley, Jr., J.M. Blair, and D.C. Coleman. 1990. Soil biota as components of sustainable agroecosystems. In *Sustainable Agricultural Systems* (C.A. Edwards, R. Lal, P. Madden, R.H. Miller, and G. House, Eds.), pp. 637–654. Soil and Water Conservation Society, Ankeny, IA.
- Heneghan, L., D.C. Coleman, X. Zou, D.A. Crossley, Jr., and B.L. Haines. 1999. Soil microarthropod contributions to decomposition dynamics: tropical-temperate comparisons of a single substrate. *Ecology* 80:1873–1882.
- Henne, D.C., and S.J. Johnson. 2007. Zombie fire ant workers: behavior controlled by decapitating fly parasitoids. *Insectes Sociaux* 54:150–153.
- Henne, D.C., S.J. Johnson, and J.T. Cronin. 2007. Population spread of the introduced red imported fire ant parasitoid, *Pseudacteon tricuspis* Borgmeier (Diptera: Phoridae), in Louisiana. *Biological Control* 42:97–104.
- Hermes, D.A., and W.J. Mattson. 1992. The dilemma of plants: to grow or defend. *Quarterly Review of Biology* 67:283–335.
- Herrera, C.M. 1989. Vertebrate frugivores and their interaction with invertebrate fruit predators: supporting evidence from a Costa Rican dry forest. *Oikos* 54:185–188.
- Herrick, J.E., and R. Lal. 1996. Dung decomposition and pedoturbation in a seasonally dry tropical pasture. *Biology and Fertility of Soils* 23:177–181.
- Herz, H., W. Beyschlag, and B. Hölldobler. 2007. Assessing herbivory rates of leaf-cutting ant (*Atta columbica*) colonies through short-term refuse deposition counts. *Biotropica* 39:476–481.
- Herzog, D.C., T.E. Reagan, D.C. Sheppard, K.M. Hyde, S.S. Nilakhe, M.Y.B. Hussein, M.L. McMahan, R.C. Thomas, and L.D. Newsom. 1976. *Solenopsis invicta* Buren: influence on Louisiana pasture soil chemistry. *Environmental Entomology* 5:160–162.
- Heuberger, S., C. Ellers-Kirk, C. Yafuso, A.J. Gassmann, B.E. Tabashnik, T.J. Dennehy, and Y. Carriere. 2008a. Effects of refuge contamination by transgenes on Bt resistance in pink bollworm (Lepidoptera: Gelichiidae). *Journal of Economic Entomology* 101:504–514.
- Heuberger, S., C. Yafuso, G. DeGrandi-Hoffman, B.E. Tabashnik, Y. Carriere, and T.J. Dennehy. 2008b. Outcrossed cottonseed and adventitious Bt plants in Arizona refuges. *Environmental Biosafety Research* 7:87–96.
- Hicks, W.T., and M.E. Harmon. 2002. Diffusion and seasonal dynamics of O<sub>2</sub> in woody debris from the Pacific Northwest, USA. *Plant and Soil* 243:67–79.
- Hik, D.S., and R.L. Jefferies. 1990. Increases in the net above-ground primary production of a salt-marsh forage grass: a test of the predictions of the herbivore-optimization model. *Journal of Ecology* 78:180–195.

- Hinton, H.E. 1960. A fly larva that tolerates dehydration and temperatures of  $-270^{\circ}$  to  $+102^{\circ}\text{C}$ . *Nature* 188:336–337.
- Hinton, H.E. 1960. Cryptobiosis in the larva of *Poly-pedilum vanderplanki* Hint. (Chironomidae). *Journal of Insect Physiology* 5:286–315.
- Hirai, H., W.S. Procnier, J.O. Ochoa, and K. Uemoto. 1994. A cytogenetic analysis of the *Simulium ochraceum* species complex (Diptera: Simuliidae) in Central America. *Genome* 37:36–53.
- Hirao, T., M. Murakami, J. Iwamoto, H. Takafumi, and H. Oguma. 2008. Scale-dependent effects of windthrow disturbance on forest arthropod communities. *Ecological Research* 23:189–196.
- Hirschel, G., C. Körner, and J.A. Arnone, III. 1997. Will rising atmospheric  $\text{CO}_2$  affect leaf litter quality and in situ decomposition rates in native plant communities? *Oecologia* 110:387–392.
- Hitchner, E.M., T.P. Kuhar, J.C. Dickens, R.R. Youngman, P.B. Schultz, and D.G. Pfeiffer. 2008. Host plant choice experiments of Colorado potato beetle (Coleoptera: Chrysomelidae) in Virginia. *Journal of Economic Entomology* 101:859–865.
- Hobbie, S.E. 2008. Nitrogen effects on decomposition: a five-year experiment in eight temperate sites. *Ecology* 89:2633–2644.
- Hochberg, M.E. 1989. The potential role of pathogens in biological control. *Nature* 337:262–265.
- Hochwender, C.G., and R.S. Fritz. 2004. Plant genetic differences influence herbivore community structure: evidence from a hybrid willow system. *Oecologia* 138:547–557.
- Hodges, J.D., S.J. Barras, and J.K. Mauldin. 1968. Free and protein-bound amino acids in inner bark of loblolly pine. *Forest Science* 14:330–333.
- Hodkinson, I.D., S.J. Coulson, J. Harrison, J. Moores, and N.R. Webb. 2001. What a wonderful web they weave: spiders, nutrient capture and early ecosystem development in the high Arctic—some counter-intuitive ideas on community assembly. *Oikos* 95:349–352.
- Hoehn, P., T. Tschardt, J.M. Tylanakis, and I. Steffan-Dewenter. 2008. Functional group diversity of bee pollinators increases crop yield. *Proceedings of the Royal Society B* 275:2283–2291.
- Hoekman, D., C. Terhorst, A. Bauer, S. Braun, P. Gignac, R. Hopkins, S. Joshi, K. Laskis, N. Sanssainte, J. Travis, and T.E. Miller. 2007. Oviposition decreased in response to enriched water: a field study of the pitcherplant mosquito, *Wyeomyia smithii*. *Ecological Entomology* 32:92–96.
- Hohn, M.E., A.M. Liebhold, and L.S. Gribko. 1993. Geostatistical model for forecasting spatial dynamics of defoliation caused by the gypsy moth (Lepidoptera: Lymantriidae). *Environmental Entomology* 22:1066–1075.
- Hokkanen, H.M.T. 1991. Trap cropping in pest management. *Annual Review of Entomology* 36:119–138.
- Hokkanen, H.M.T., J.C. van Lenteren, and I. Menzler-Hokkanen. 2007. Ecological risks of biological control agents: impacts on IPM. In *Perspectives in Ecological Theory and Integrated Pest Management* (M. Kogan, and P. Jepson, Eds.), pp. 246–268. Cambridge University Press, Cambridge, UK.
- Holdo, R.M., and L.R. McDowell. 2004. Termite mounds as nutrient-rich food patches for elephants. *Biotropica* 36:231–239.
- Holland, J.N. 1995. Effects of above-ground herbivory on soil microbial biomass in conventional and no-tillage agroecosystems. *Applied Soil Ecology* 2:275–279.
- Holland, J.N., and D.L. De Angelis. 2009. Consumer-resource theory predicts dynamic transitions between outcomes of interspecific interactions. *Ecology Letters* 12:1357–1366.
- Holland, J.N., W. Cheng, and D.A. Crossley, Jr. 1996. Herbivore-induced changes in plant carbon allocation: assessment of below-ground C fluxes using carbon-14. *Oecologia* 107:87–94.
- Hölldobler, B. 1995. The chemistry of social regulation: multicomponent signals in ant societies. *Proceedings of the National Academy of Sciences, USA* 92:19–22.
- Hollenhorst, S.J., S.M. Brock, W.A. Freimund, and M.J. Twery. 1993. Predicting the effects of gypsy moth on near-view aesthetic preferences and recreation appeal. *Forest Science* 39:28–40.
- Holling, C.S. 1959. Some characteristics of simple types of predation and parasitism. *Canadian Entomologist* 91:385–398.
- Holling, C.S. 1965. The functional response of predators to prey density and its role in mimicry and population regulation. *Memoirs of the Entomological Society of Canada* 45:1–60.
- Holling, C.S. 1966. The functional response of invertebrate predators to prey density. *Memoirs of the Entomological Society of Canada* 48:1–86.
- Holling, C.S. 1973. Resilience and stability of ecological systems. *Annual Review of Ecology and Systematics* 4:1–23.
- Holling, C.S. 1992. Cross-scale morphology, geometry, and dynamics of ecosystems. *Ecological Monographs* 62:447–502.
- Hollinger, D.Y. 1986. Herbivory and the cycling of nitrogen and phosphorus in isolated California oak trees. *Oecologia* 70:291–297.
- Holopainen, J.K., R. Rikala, P. Kainulainen, and J. Oksanen. 1995. Resource partitioning to growth, storage and defence in nitrogen-fertilized Scots pine and susceptibility of the seedlings to the tarnished plant bug *Lygus rugulipennis*. *New Phytologist* 131:521–532.
- Holter, P. 1979. Effect of dung-beetles (*Aphodius* spp.) and earthworms on the disappearance of cattle dung. *Oikos* 32:393–402.
- Holzschuh, A., I. Steffan-Dewenter, D. Kleijn, and T. Tschardt. 2007. Diversity of flower-visiting bees

- in cereal fields: effects of farming system, landscape composition and regional context. *Journal of Applied Ecology* 44:41–49.
- Honek, A., Z. Martinkova, P. Saska, and S. Koprdoва. 2009. Role of post-dispersal seed and seedling predation in establishment of dandelion (*Taraxacum* agg.) plants. *Agriculture, Ecosystems and Environment* 134:126–135.
- Honkanen, T., E. Haukioja, and J. Suomela. 1994. Effects of simulated defoliation and debudding on needle and shoot growth in Scots pine (*Pinus sylvestris*): implications of plant source/sink relationships for plant–herbivore studies. *Functional Ecology* 8:631–639.
- Hoogendoorn, M., and G.E. Heimpel. 2001. PCR-based gut content analysis of insect predators: using ribosomal ITS-1 fragments from prey to estimate predation frequency. *Molecular Ecology* 10:2059–2067.
- Hooker, J.D. 1847. The Botany of the Antarctic Voyage of H.M. Discovery Ships Erebus and Terror, in the Years 1839–1843. Vol. 1. Flora Antarctica. Reeve, Brothers, London, UK.
- Hooker, J.D. 1853. The Botany of the Antarctic Voyage of H.M. Discovery Ships Erebus and Terror, in the Years 1839–1843. Vol. 2. Flora Novae-Zelandiae. Reeve, Brothers, London, UK.
- Hooker, J.D. 1860. The Botany of the Antarctic Voyage of H.M. Discovery Ships Erebus and Terror, in the Years 1839–1843. Vol. 3. Flora Tasmaniae. Reeve, Brothers, London, UK.
- Hooper, D.U., and P.M. Vitousek. 1997. The effects of plant composition and diversity on ecosystem processes. *Science* 277:1302–1305.
- Hooper, D.U., F.S. Chapin, III, J.J. Ewel, A. Hector, P. Inchausti, S. Lavorel, J.H. Lawton, D.M. Lodge, M. Loreau, S. Naeem, B. Schmid, H. Setälä, A.J. Symstad, J. Vandermeer, and D.A. Wardle. 2005. Effects of biodiversity on ecosystem functioning: a consensus of current knowledge. *Ecological Monographs* 75:3–35.
- Hopkins, R.J., N.M. van Dam, and J.J.A. van Loon. 2009. Role of glucosinolates in insect–plant relationships and multitrophic interactions. *Annual Review of Entomology* 54:57–83.
- Horn, H.S. 1981. Some causes of variety in patterns of secondary succession. In *Forest Succession: Concepts and Application* (D.C. West, H.H. Shugart, and D.B. Botkin, Eds.), pp. 24–35. Springer-Verlag, New York, NY.
- Horn, M.H. 1997. Evidence for dispersal of fig seeds by the fruit-eating characid fish *Brycon guatemalensis* Regan in a Costa Rican tropical rain forest. *Oecologia* 109:259–264.
- Horridge, A. 2003. Visual resolution of the orientation cue by the honeybee (*Apis mellifera*). *Journal of Insect Physiology* 49:1145–1152.
- Horváth, G., G. Kriska, P. Malik, and B. Robertson. 2009. Polarized light pollution: a new kind of ecological photopollution. *Frontiers in Ecology and the Environment* 7:317–325.
- Horvitz, C.C., and D.W. Schemske. 1986. Ant-nest soil and seedling growth in a neotropical ant-dispersed herb. *Oecologia* 70:318–320.
- Horvitz, C.C., S. Tuljapurkar, and J.B. Pascarella. 2005. Plant–animal interactions in random environments: habitat-stage elasticity, seed predators and hurricanes. *Ecology* 86:3312–3322.
- Horwath, W.R., E.A. Paul, D. Harris, J. Norton, L. Jagger, and K.A. Horton. 1996. Defining a realistic control for the chloroform fumigation-incubation method using microscopic counting and <sup>14</sup>C-substrates. *Canadian Journal of Soil Science* 76:459–467.
- Hossain, F., I. Jeyachandran, and R. Pielke. 2009. Have large dams altered extreme precipitation patterns? *EOS, Transactions, American Geophysical Union* 90:453–454.
- Houlahan, J.E., J.D. Currie, K. Cottanie, G.S. Cumming, S.K.M. Earnest, C.S. Findlay, S.D. Fuhlen-dorf, U. Gaedke, P. Legendre, J.J. Magnuson, B.H. McArdle, E.H. Muldavin, D. Noble, R. Russell, R.D. Stevens, T.J. Willis, I.P. Woiwod, and S.M. Wondzell. 2007. Compensatory dynamics are rare in natural ecological communities. *Proceedings of the National Academy of Science, USA* 104:3273–3277.
- Howard, L.O. 1896. The Mexican Cotton Boll Weevil. USDA Bureau of Entomology Circular 14.
- Howe, H.F., and J. Smallwood. 1982. Ecology of seed dispersal. *Annual Review of Ecology and Systematics* 13:201–228.
- Hsu, J.-C., H.-T. Feng, and W.-J. Wu. 2004. Resistance and synergistic effects of insecticides in *Bactrocera dorsalis* (Diptera: Tephritidae) in Taiwan. *Journal of Economic Entomology* 97:1682–1688.
- Hsu, J.-C., D.S. Haymer, W.-J. Wu, and H.-T. Feng. 2006. Mutations in the acetylcholinesterase gene of *Bactrocera dorsalis* associated with resistance organophosphorus insecticides. *Insect Biochemistry and Molecular Biology* 38:396–402.
- Hsu, J.-C., W.-J. Wu, D.S. Haymer, H.-Y. Liao, and H.-T. Feng. 2008. Alterations of the acetylcholinesterase enzyme in the oriental fruit fly *Bactrocera dorsalis* are correlated with resistance to the organophosphate insecticide fenitrothion. *Insect Biochemistry and Molecular Biology* 38:146–154.
- Huang, C.-Y., C.-P. Wang, and P.-C. Hou. 2007. Toads (*Bufo bankorensis*) influence litter chemistry but not litter invertebrates and litter decomposition rates in a subtropical forest of Taiwan. *Journal of Tropical Ecology* 23:161–168.
- Huang, F., B.R. Leonard, and D.A. Andow. 2007. Sugarcane borer (Lepidoptera: Crambidae) resistance to transgenic *Bacillus thuringiensis* maize. *Journal of Economic Entomology* 100:164–171.
- Huberty, A.F., and R.F. Denno. 2006. Trade-off in investment between dispersal and ingestion capability

- in phytophagous insects and its ecological implications. *Oecologia* 148:226–234.
- Hudgins, J.W., E. Christiansen, and V.R. Franceschi. 2003. Methyl jasmonate induces changes mimicking anatomical defenses in diverse members of the Pinaceae. *Tree Physiology* 23:361–371.
- Hudgins, J.W., E. Christiansen, and V.R. Franceschi. 2004. Induction of anatomically based defensive responses in stems of diverse conifers by methyl jasmonate: a phylogenetic perspective. *Tree Physiology* 24:251–264.
- Huettl, R.F., and D. Mueller-Dombois (Eds.) 1993. Forest Declines in the Atlantic and Pacific Regions. Springer-Verlag, Berlin, Germany.
- Huffaker, C.B., and P.S. Messenger (Eds.) 1976. Theory and Practice of Biological Control. Academic, New York, NY.
- Hughes, L. 1990. The relocation of ant nest entrances: potential consequences for ant-dispersed seeds. *Australian Journal of Ecology* 16:207–214.
- Hughes, L., and F.A. Bazzaz. 1997. Effect of elevated CO<sub>2</sub> on interactions between the western flower thrips, *Frankliniella occidentalis* (Thysanoptera: Thripidae) and the common milkweed, *Asclepias syriaca*. *Oecologia* 109:286–290.
- Hughes, R.D., M. Tyndale-Biscoe, and J. Walker. 1978. Effects of introduced dung beetles (Coleoptera: Scarabaeidae) on the breeding and abundance of the Australian bushfly, *Musca vetustissima* Walker (Diptera: Muscidae). *Bulletin of Entomological Research* 68:361–372.
- Huhta, V., J. Haimi, and H. Setälä. 1991. Role of the fauna in soil processes: techniques using simulated forest floor. *Agriculture, Ecosystems and Environment* 34:223–229.
- Hulme, M.A., and J.K. Shields. 1970. Biological control of decay fungi in wood by competition for non-structural carbohydrates. *Nature* 227:300–301.
- Hulme, P.E. 1994. Seedling herbivory in grassland: relative impact of vertebrate and invertebrate herbivores. *Journal of Ecology* 82:873–880.
- Hulme, P.E., P. Pyšek, W. Nentwig, and M. Vilà. 2009. Will threat of biological invasions unite the European Union? *Science* 324:40–41.
- Hultmark, D., A. Engström, H. Bennich, R. Kapur, and H.G. Boman. 1982. Insect immunity: isolation and structure of cecropin D and four minor antibacterial components from cecropia pupae. *European Journal of Biochemistry* 127:207–217.
- Hung, C.F., C.H. Kao, C.C. Liu, J.G. Lin, and C.N. Sun. 1990. Detoxifying enzymes of selected insect species with chewing and sucking habits. *Journal of Economic Entomology* 83:361–365.
- Hunt, H.W., D.C. Coleman, E.R. Ingham, R.E. Ingham, E.T. Elliott, J.C. Moore, S.L. Rose, C.P.P. Reid, and C.R. Morley. 1987. The detrital food web in a shortgrass prairie. *Biology and Fertility of Soils* 3:57–68.
- Hunter, A.F., and L.W. Arssen. 1988. Plants helping plants. *BioScience* 38:34–40.
- Hunter, A.F., and J.S. Elkinton. 2000. Effects of synchrony with host plant on populations of a spring-feeding lepidopteran. *Ecology* 81:1248–1261.
- Hunter, M.D. 1987. Opposing effects of spring defoliation on late season oak caterpillars. *Ecological Entomology* 12:373–382.
- Hunter, M.D. 1992. A variable insect–plant interaction: the relationship between tree budburst phenology and population levels of insect herbivores among trees. *Ecological Entomology* 17:91–95.
- Hunter, M.D. 2001a. Out of sight, out of mind: the impacts of root-feeding insects in natural and managed systems. *Agricultural and Forest Entomology* 3:3–9.
- Hunter, M.D. 2001b. Insect population dynamics meets ecosystem ecology: effects of herbivory on soil nutrient dynamics. *Agricultural and Forest Entomology* 3:77–84.
- Hunter, M.D. 2009. Trophic promiscuity, intraguild predation and the problem of omnivores. *Agricultural and Forest Entomology* 11:125–131.
- Hunter, M.D., and R.E. Forkner. 1999. Hurricane damage influences foliar polyphenolics and subsequent herbivory on surviving trees. *Ecology* 80:2676–2682.
- Hunter, M.D., and P.W. Price. 1992. Playing chutes and ladders: heterogeneity and the relative roles of bottom–up and top–down forces in natural communities. *Ecology* 73:724–732.
- Hunter, M.D., and J.C. Schultz. 1993. Induced plant defenses breached? Phytochemical induction protects an herbivore from disease. *Oecologia* 94:195–203.
- Hunter, M.D., and J.C. Schultz. 1995. Fertilization mitigates chemical induction and herbivore responses within damaged oak trees. *Ecology* 76:1226–1232.
- Hunter, M.D., S. Adl, C.M. Pringle, and D.C. Coleman. 2003. Relative effects of macroinvertebrates and habitat on the chemistry of litter during decomposition. *Pedobiologia* 47:101–115.
- Hunter, M.R., and M.D. Hunter. 2008. Designing for conservation of insects in the built environment. *Insect Conservation and Diversity* 1:189–196.
- Hunter, W.D., and W.E. Hinds. 1904. The Mexican Cotton Boll Weevil. USDA Division of Entomology Bulletin 45. Government Printing Office, Washington, DC.
- Huntly, N. 1991. Herbivores and the dynamics of communities and ecosystems. *Annual Review of Ecology and Systematics* 22:477–503.
- Hurlbert, S.H. 1984. Pseudoreplication and the design of ecological field experiments. *Ecological Monographs* 54:187–211.
- Hurny, A.D., and J.B. Wallace. 1987. Local geomorphology as a determinant of macrofaunal production in a mountain stream. *Ecology* 68:1932–1942.

- Huryn, A.D., and J.B. Wallace. 2000. Life history and production of stream insects. *Annual Review of Entomology* 45:83–110.
- Husseneder, C., and J.K. Grace. 2001a. Similarity is relative: hierarchy of genetic similarities in the Formosan subterranean termite (Isoptera: Rhinotermitidae) in Hawaii. *Environmental Entomology* 30:262–266.
- Husseneder, C., and J.K. Grace. 2001b. Evaluation of DNA fingerprinting, aggression tests, and morphometry as tools for colony delineation of the Formosan subterranean termite. *Journal of Insect Behavior* 14:173–186.
- Husseneder, C., R. Brandl, C. Epplen, J.T. Epplen, and M. Kaib. 1998. Variation between and within colonies in the termite: morphology, genomic DNA, and behaviour. *Molecular Ecology* 7:983–990.
- Husseneder, C., R. Brandl, C. Epplen, J.T. Epplen, and M. Kaib. 1999. Within-colony relatedness in a termite species: genetic roads to eusociality? *Behaviour* 136:1045–1063.
- Husseneder, C., E.L. Vargo, and J.K. Grace. 2003. Molecular genetic methods: new approaches to termite biology. In *Wood Deterioration and Preservation: Advances in Our Changing World* (B. Goodell, D.D. Nicholas, and T.P. Schultz, Eds.), pp. 358–369. American Chemical Society, Washington, DC.
- Huston, M. 1979. A general hypothesis of species diversity. *American Naturalist* 113:81–101.
- Hutchinson, G.E. 1959. Homage to Santa Rosalia or why are there so many kinds of animals? *American Naturalist* 93:145–159.
- Huxley, C.R., and D.F. Cutler. 1991. Ant–plant Interactions. Oxford University Press, Oxford, UK.
- Ingham, E.R. 1985. Review of the effects of 12 selected biocides on target and non-target soil organisms. *Crop Protection* 4:3–32.
- Ingham, E.R., C. Cambardella, and D.C. Coleman. 1986. Manipulation of bacteria, fungi and protozoa by biocides in lodgepole pine forest soil microcosms: effects on organism interactions and nitrogen mineralization. *Canadian Journal of Soil Science* 66:261–272.
- Ingham, R.E., J.A. Trofymow, E.R. Ingham, and D.C. Coleman. 1985. Interactions of bacteria, fungi, and their nematode grazers: effects on nutrient cycling and plant growth. *Ecological Monographs* 55:119–140.
- Inouye, B., and J.R. Stinchcombe. 2001. Relationships between ecological interaction modifications and diffuse coevolution: similarities, differences, and causal links. *Oikos* 95:353–360.
- Inouye, D.W. 1982. The consequences of herbivory: a mixed blessing for *Jurinea mollis* (Asteraceae). *Oikos* 39:269–272.
- Inouye, R.S., G.S. Byers, and J.H. Brown. 1980. Effects of predation and competition on survivorship, fecundity, and community structure of desert annuals. *Ecology* 61:1344–1351.
- Irby, W.S., and C.S. Apperson. 1988. Hosts of mosquitoes in the coastal plain of North Carolina. *Journal of Medical Entomology* 25:85–93.
- Irvine, J., B.E. Law, and M.R. Kurpius. 2005. Coupling of canopy gas exchange with root and rhizosphere respiration in a semi-arid forest. *Biogeochemistry* 73:271–282.
- Isaacs, R., and D.N. Byrne. 1998. Aerial distribution, flight behaviour and eggload: their inter-relationship during dispersal by the sweetpotato whitefly. *Journal of Animal Ecology* 67:741–750.
- Isaacs, R., J. Tuell, A. Fiedler, M. Gardiner, and D. Landis. 2009. Maximizing arthropod-mediated ecosystem services in agricultural landscapes: the role of native plants. *Frontiers in Ecology and the Environment* 7:196–203.
- Isaev, A.S., and R.G. Khlebopros. 1979. Inertial and noninertial factors regulating forest insect population density. In *Pest Management. Proceed. International Conference. Oct. 25–29, 1976* (G.A. Norton, and C.S. Holling, Eds.), pp. 317–339. Pergamon Press, Oxford, UK.
- Ishii, Y., and M. Shimada. 2010. The effect of learning and search images on predator–prey interactions. *Population Ecology* 52:27–35.
- Ishimoto, H., T. Sakai, and T. Kitamoto. 2009. Ecdysone signaling regulates the formation of long-term courtship memory in adult *Drosophila melanogaster*. *Proceedings of the National Academy of Science, USA* 106:6381–6386.
- Istock, C.A. 1973. Population characteristics of a species ensemble of water-boatmen (Corixidae). *Ecology* 54:535–544.
- Istock, C.A. 1977. Logistic interaction of natural populations of two species of waterboatmen. *American Naturalist* 111:279–287.
- Istock, C.A. 1981. Natural selection and life history variation: theory plus lessons from a mosquito. In *Insect Life History Patterns: Habitat and Geographic Variation* (R.F. Denno, and H. Dingle, Eds.), pp. 113–127. Springer-Verlag, New York, NY.
- Ives, A.R., and D.A. Andow. 2002. Evolution of resistance to Bt crops: directional selection in structured environments. *Ecology Letters* 5:792–801.
- Iwasaki, T. 1990. Predatory behavior of the praying mantis, *Tenodera aridifolia*. I. effect of prey size on prey recognition. *Journal of Ethology* 8:75–79.
- Iwasaki, T. 1991. Predatory behavior of the praying mantis, *Tenodera aridifolia*. II. Combined effect of prey size and predator size on the prey recognition. *Journal of Ethology* 9:77–81.
- Jabłoński, P. 1999. A rare predator exploits prey escape behavior: the role of tail-fanning and plumage contrast in foraging of the painted redstart (*Myioborus pictus*). *Behavioral Ecology* 10:7–14.
- Jackson, D.M., A.W. Johnson, and M.G. Stephenson. 2002. Survival and development of *Heliothis virescens* (Lepidoptera: Noctuidae) larvae on isogenic

- tobacco lines with different levels of alkaloids. *Journal of Economic Entomology* 95:1294–1302.
- Jackson, R.V., J. Kollmann, R.J. Grubb, and J.N. Bee. 1999. Insect herbivory on five European tall-shrub species related to leaf ontogeny and quality, and the need to distinguish pre-expansion and expanding leaves. *Oikos* 87:561–570.
- Jactel, H., and E.G. Brockerhoff. 2007. Tree diversity reduces herbivory by forest insects. *Ecology Letters* 10:835–848.
- Jandér, K.C., and E.A. Herre. 2010. Host sanctions and pollinator cheating in the fig tree-fig wasp mutualism. *Proceedings of the Royal Society B* 277:1481–1488.
- Janssen, R.H.H., M.B.J. Meinders, E.H. van Nes, and M. Scheffer. 2008. Microscale vegetation–soil feedback boosts hysteresis in a regional vegetation–climate system. *Global Change Biology* 14:1104–1112.
- Janzen, D.H. 1966. Coevolution of mutualism between ants and acacias in Central America. *Evolution* 20:249–275.
- Janzen, D.H. 1977. What are dandelions and aphids? *American Naturalist* 111:586–589.
- Janzen, D.H. 1981. Patterns of herbivory in a tropical deciduous forest. *Biotropica* 13:271–282.
- Janzen, D.H. 1985. On ecological fitting. *Oikos* 45:308–310.
- Janzen, D.H., and P.S. Martin. 1982. Neotropical anachronisms: the fruits the gomphotheres ate. *Science* 215:19–27.
- Jarosz, J. 1995. Haemolymph immune proteins protect the insect body cavity from invading bacteria. *Comparative Biochemistry and Physiology* 111C:213–220.
- Jeffries, J.M., R.J. Marquis, and R.E. Forkner. 2006. Forest age influences oak insect community structure, richness, and density. *Ecological Applications* 16:901–912.
- Jenkins, M.J., E. Herbertson, W. Page, and C.A. Jorgensen. 2008. Bark beetles, fuels, fires and implications for forest management in the Intermountain West. *Forest Ecology and Management* 254:16–34.
- Jentsch, A., J. Kreyling, and C. Beierkuhnlein. 2007. A new generation of climate-change experiments: events, not trends. *Frontiers in Ecology and the Environment* 5:365–374.
- Jepsen, J.U., S.B. Hagen, R.A. Ims, and N.G. Yacoz. 2008. Climate change and outbreaks of the geometrids *Operophtera brumata* and *Epirrita autumnata* in subarctic birch forest: evidence of a recent outbreak range expansion. *Journal of Animal Ecology* 77:257–264.
- Jepson, P.C., and J.R.M. Thacker. 1990. Analysis of the spatial component of pesticide side-effects on non-target invertebrate populations and its relevance to hazard analysis. *Functional Ecology* 4:349–355.
- Jetz, W., C. Carbone, J. Fulford, and J.H. Brown. 2004. The scaling of animal space use. *Science* 306:266–268.
- Jhee, E.M., K.L. Dandridge, A.M. Christy, Jr., and A.J. Pollard. 1999. Selective herbivory on low-zinc phenotypes of the hyperaccumulator *Thlaspi caerulescens* (Brassicaceae). *Chemoecology* 9:93–95.
- Joel, D.M., B.E. Juniper, and A. Dafni. 1985. Ultraviolet patterns in the traps of carnivorous plants. *New Phytologist* 101:585–593.
- Joern, A., and S.T. Behmer. 1998. Impact of diet quality on demographic attributes in adult grasshoppers and the nitrogen limitation hypothesis. *Ecological Entomology* 23:174–184.
- Johansson, F. 1993. Effects of prey type, prey density and predator presence on behaviour and predation risk in a larval damselfly. *Oikos* 68:481–489.
- Johnsen, S., and K.J. Lohmann. 2005. The physics and neurobiology of magnetoreception. *Nature Reviews: Neuroscience* 6:703–712.
- Johnson, D.M. 2004. Life history and demography of *Cephaloleia fenestrata* (Hispinae: Chrysomelidae: Coleoptera). *Biotropica* 36:352–361.
- Johnson, D.M., O.N. Bjørnstad, and A.M. Liebhold. 2004. Landscape geometry and traveling waves in the larch budmoth. *Ecology Letters* 7:967–974.
- Johnson, D.M., A.M. Liebhold, O.N. Bjørnstad, and M.L. McManus. 2005. Circumpolar variation in periodicity and synchrony among gypsy moth populations. *Journal of Animal Ecology* 74:882–892.
- Johnson, D.M., A.M. Liebhold, P.C. Tobin, and O.N. Bjørnstad. 2006. Allee effects and pulsed invasion by the gypsy moth. *Nature* 444:361–363.
- Johnson, K.A., and W.G. Whitford. 1975. Foraging ecology and relative importance of subterranean termites in Chihuahuan Desert ecosystems. *Environmental Entomology* 4:66–70.
- Johnson, M.L., S. Armitage, B.C.G. Scholz, D.J. Merritt, B.W. Cribb, and M.P. Zalucki. 2006. Predator presence moves *Helicoverpa armigera* larvae to distraction. *Journal of Insect Behavior* 20:1–18.
- Johnson, M.P., and D.S. Simberloff. 1974. Environmental determinants of island species numbers in the British Isles. *Journal of Biogeography* 1:149–154.
- Johnson, M.T.J., and A.A. Agrawal. 2005. Plant genotype and environment interact to shape a diverse arthropod community on evening primrose (*Oenothera biennis*). *Ecology* 86:874–885.
- Johnson, M.T.J., M.J. Lajeunesse, and A.A. Agrawal. 2006. Additive and interactive effects of plant genotypic diversity on arthropod communities and plant fitness. *Ecology Letters* 9:24–34.
- Johnson, R.M., J.D. Evans, G.E. Robinson, and M.R. Berenbaum. 2009. Changes in transcript abundance relating to colony collapse disorder in honey bees (*Apis mellifera*). *Proceedings of the National Academy of Science, USA* 106:14790–14795.
- Johnson, S.D., and W.J. Bond. 1994. Red flowers and butterfly pollination in the fynbos of South Africa. In *Plant–animal Interactions in Mediterranean-type*



- Ecosystems* (M. Arianoutsou, and R.H. Graves, Eds.), pp. 137–148. Kluwer, Dordrecht, The Netherlands.
- Johnson, S.D., C.L. Collin, H.J. Wissman, E. Halvarsson, and J. Ågren. 2004. Factors contributing to variation in seed production among remnant populations of the endangered daisy *Gerbera aurantiaca*. *Biotropica* 36:148–155.
- Jolivet, P. 1996. *Ants and Plants: an Example of Co-evolution*. Backhuys Publishers, Leiden, The Netherlands.
- Jonas, J.L., and A. Joern. 2007. Grasshopper (Orthoptera: Acrididae) communities respond to fire, bison grazing and weather in North American tall-grass prairie: a long-term study. *Oecologia* 153:699–711.
- Jøndrup, P.M., J.D. Barnes, and G.R. Port. 2002. The effect of ozone fumigation and different *Brassica rapa* lines on the feeding behaviour of *Pieris brassicae* larvae. *Entomologia Experimentalis et Applicata* 104:143–151.
- Jones, C.G. 1984. Microorganisms as mediators of plant resource exploitation by insect herbivores. In *A New Ecology: Novel Approaches to Interactive Systems* (P.W. Price, W.S. Gaud, and C.N. Slobodchikoff, Eds.), pp. 53–100. John Wiley, New York, NY.
- Jones, C.G., J.H. Lawton, and M. Shachak. 1994. Organisms as ecosystem engineers. *Oikos* 69:373–386.
- Jones, C.G., R.S. Ostfeld, M.P. Richard, E.M. Schaubert, and J.O. Wolff. 1998. Chain reactions linking acorns to gypsy moth outbreaks and lyme disease risk. *Science* 279:1023–1026.
- Jones, C.R. 1917. Grasshopper control. Colorado Agricultural Experiment Station Bulletin 233, Ft. Collins, CO.
- Jones, J.A. 1989. Environmental influences on soil chemistry in central semiarid Tanzania. *Soil Science Society of America Journal* 53:1748–1758.
- Jones, J.A. 1990. Termites, soil fertility and carbon cycling in dry tropical Africa: a hypothesis. *Journal of Tropical Ecology* 6:291–305.
- Jones, M.E., T.D. Paine, M.E. Fenn, and M.A. Poth. 2004. Influence of ozone and nitrogen deposition on bark beetle activity under drought conditions. *Forest Ecology and Management* 200:67–76.
- Jonkman, J.C.M. 1978. Nests of the leaf-cutting ant *Atta vollenweideri* as accelerators of succession in pastures. *Zeitschrift für angewandte Entomologie* 86:25–34.
- Jouquet, P., J. Dauber, J. Lagerlöf, P. Lavelle, and M. Lapage. 2006. Soil invertebrates as ecosystem engineers: effects on soil and feedback loops. *Applied Soil Ecology* 32:153–164.
- Juang, J.-Y., G.G. Katul, A. Porporato, P.C. Stoy, M.S. Sequeira, M. Detto, H.-S. Kim, and R. Oren. 2007. Eco-hydrological controls on summertime convective rainfall triggers. *Global Change Biology* 13:887–896.
- Jung, C., and B.A. Croft. 2001. Aerial dispersal of phytoseiid mites (Acari: Phytoseiidae): estimating falling speed and dispersal distance of adult females. *Oikos* 94:182–190.
- Juniper, B.E., R.J. Robins, and D.M. Joel. 1989. *The Carnivorous Plants*. Academic Press, London, UK.
- Jurgensen, M.F., L. Finér, T. Domisch, J. Kilpeläinen, P. Punttila, M. Ohashi, P. Niemelä, L. Sundström, S. Neuvonen, and A.C. Risch. 2008. Organic mound-building ants: their impact on soil properties in temperate and boreal forests. *Journal of Applied Entomology* 132:266–275.
- Käärik, A.A. 1974. Decomposition of wood. In *Biology of Plant Litter Decomposition* (C.H. Dickinson, and G.J.F. Pugh, Eds.), pp. 129–174. Academic Press, London, UK.
- Kaczmarek, M., and A. Wasilewski. 1977. Dynamics of numbers of the leaf-eating insects and its effect on foliage production in the “Grabowy” Reserve in the Kampinos National Park. *Ekologia Polska* 25:653–673.
- Kaib, M., C. Husseneder, C. Epplen, J.T. Epplen, and R. Brandl. 1996. Kin-biased foraging in a termite. *Proceedings of the Royal Society, London B* 263:1527–1532.
- Kainulainen, P., J.K. Holopainen, H. Hyttinen, and J. Oksanen. 1994. Effect of ozone on the biochemistry and aphid infestation of Scots pine. *Phytochemistry* 35:39–42.
- Kaiser, J. 2005. *Acadia: The Complete Guide: Mount Desert Island and Acadia National Park*. Destination Press.
- Kamil, A.C., J.R., Krebs, and H.R., Pulliam (Eds.) 1987. *Foraging Behavior*. Plenum Press, New York, NY.
- Kaplan, I., R. Halitschke, A. Kessler, S. Sardaneli, and R.F. Denno. 2008. Constitutive and induced defenses to herbivory in above- and belowground plant tissues. *Ecology* 89:392–406.
- Karban, R. 2001. Communication between sagebrush and wild tobacco in the field. *Biochemical Systematics and Ecology* 29:995–1005.
- Karban, R., and A.A. Agrawal. 2002. Herbivore offense. *Annual Review of Ecology and Systematics* 33:641–664.
- Karban, R., and I.T. Baldwin. 1997. *Induced responses to herbivory*. University of Chicago Press, Chicago, IL.
- Karban, R., and J. Maron. 2002. The fitness consequences of interspecific eavesdropping between plants. *Ecology* 83:1209–1213.
- Karban, R., and C. Niiho. 1995. Induced resistance and susceptibility to herbivory: plant memory and altered plant development. *Ecology* 76:1220–1225.
- Karban, R., I.T. Baldwin, K.J. Baxter, G. Laue, and G.W. Felton. 2000. Communication between plants: induced resistance in wild tobacco plants following clipping of neighboring sagebrush. *Oecologia* 125:66–71.

- Kareiva, P. 1983. Influence of vegetation texture on herbivore populations: resource concentration and herbivore movement. In *Variable Plants and Herbivores in Natural and Managed Systems* (R.F. Denno, and M.S. McClure, Eds.), pp. 259–289. Academic Press, New York, NY.
- Karley, A.J., W.E. Parker, J.W. Pitchford, and A.E. Douglas. 2004. The mid-season crash in aphid populations: why and how does it occur? *Ecological Entomology* 29:383–388.
- Kasina, J.M., J. Mburu, M. Kraemer, and K. Holm-Mueller. 2009. Economic benefit of crop pollination by bees: a case of Kakamega small-holder farming in western Kenya. *Journal of Economic Entomology* 102:467–473.
- Kaushal, S.S., M.L. Pace, P.M. Groffman, L.E. Band, K.T. Belt, P.M. Mayer, and C. Welty. 2010. Land use and climate variability amplify contaminant pulses. *EOS, Transactions American Geophysical Union* 91:221–222.
- Kawaguchi, Y., and S. Nakano. 2001. Contribution of terrestrial invertebrates to the annual resource budget for salmonids in forest and grassland reaches of a headwater stream. *Freshwater Biology* 46:303–316.
- Kawecki, T.J. 2010. Evolutionary ecology of learning: insights from fruit flies. *Population Ecology* 52:15–25.
- Keeling, C.D., T.P. Whorf, M. Wahlen, and J. van der Plicht. 1995. Interannual extremes in the rate of rise of atmospheric carbon dioxide since 1980. *Science* 375:666–670.
- Keeton, W.S., and J.F. Franklin. 2005. Do remnant old-growth trees accelerate rates of succession in mature Douglas-fir forests? *Ecological Monographs* 75:103–118.
- Kelly, D.J., M.L. Bothwell, and D.W. Schindler. 2003. Effects of solar ultraviolet radiation on stream benthic communities: an intersite comparison. *Ecology* 84:2724–2740.
- Kempton, R.A. 1979. The structure of species abundance and measurement of diversity. *Biometrics* 35:307–321.
- Kennedy, J.S. 1975. Insect dispersal. In *Insects, Science, and Society* (D. Pimentel, Ed.), pp. 103–119. Academic Press, New York, NY.
- Kerridge, A., H. Lappin-Scott, and J.R. Stevens. 2005. Antibacterial properties of larval secretions of the blowfly, *Lucilia sericata*. *Medical and Veterinary Entomology* 19:333–337.
- Kessler, A., and I.T. Baldwin. 2001. Defensive function of herbivore-induced plant volatile emissions in nature. *Science* 291:2141–2144.
- Kessler, A., and I.T. Baldwin. 2002. Plant responses to herbivory: the emerging molecular analysis. *Annual Review of Plant Biology* 53:299–328.
- Kessler, A., R. Halitschke, and I.T. Baldwin. 2004. Silencing the jasmonate cascade: induced plant defenses and insect populations. *Science* 305:665–668.
- Kessler, A., R. Halitschke, C. Diezel, and I.T. Baldwin. 2006. Priming of plant defense responses in nature by airborne signaling between *Artemisia tridentata* and *Nicotiana attenuata*. *Oecologia* 148:280–292.
- Kettlewell, H.B.D. 1956. Further selection experiments on industrial melanism in the Lepidoptera. *Heredity* 10:287–301.
- Key, K.H.L., and M.F. Day. 1954. A temperature-controlled physiological colour response in the grasshopper *Kosciuscola tristis* Sjöst. (Orthoptera: Acrididae). *Australian Journal of Zoology* 2:309–339.
- Khalil, M.A.K., R.A. Rasmussen, J.R.J. French, and J.A. Holt. 1990. The influence of termites on atmospheric trace gases: CH<sub>4</sub>, CO<sub>2</sub>, CHCl<sub>3</sub>, N<sub>2</sub>O, CO, H<sub>2</sub>, and light hydrocarbons. *Journal of Geophysical Research* 95:3619–3634.
- Kharboul, M.S., and T.P. Mack. 1993. Tolerance of the striped earwig (Dermaptera: Labiduridae) to hot and dry conditions. *Environmental Entomology* 22:663–668.
- Kiffney, P.M., J.S. Richardson, and J.P. Bull. 2003. Responses of periphyton and insects to experimental manipulation of riparian buffer width along forest streams. *Journal of Applied Ecology* 40:1060–1076.
- Kiilgaard, C.W., S.E. Greene, and S.G. Stafford. 1987. Nutrient concentration in litterfall from some western conifers with special reference to calcium. *Plant and Soil* 102:223–227.
- Kikkert, D.A., T.A. Crowl, and A.P. Covich. 2009. Upstream migration of amphidromous shrimps in the Luquillo Experimental Forest, Puerto Rico: temporal patterns and environmental cues. *Journal of the North American Benthological Society* 28:233–246.
- Kim, Y., and N. Kim. 1997. Cold hardiness in *Spodoptera exigua* (Lepidoptera: Noctuidae). *Environmental Entomology* 26:1117–1123.
- Kimberling, D.N., J.R. Karr, and L.S. Fore. 2001. Measuring human disturbance using terrestrial invertebrates in the shrub-steppe of eastern Washington (USA). *Ecological Indicators* 1:63–81.
- Kimmins, J.P. 1972. Relative contributions of leaching, litterfall, and defoliation by *Neodiprion sertifer* (Hymenoptera) to the removal of cesium-134 from red pine. *Oikos* 23:226–234.
- King, A.A., R.F. Costantino, J.M. Cushing, S.M. Henson, R.A. Desharnais, and B. Dennis. 2004. Anatomy of a chaotic attractor: subtle model-predicted patterns revealed in population data. *Proceedings of the National Academy of Sciences, USA* 101:408–413.
- King, T.J. 1977a. The plant ecology of ant-hills in calcareous grasslands. I. Patterns of species in relation to ant-hills in southern England. *Journal of Ecology* 65:235–256.
- King, T.J. 1977b. The plant ecology of ant-hills in calcareous grasslands. II. Succession on the mounds. *Journal of Ecology* 65:257–278.
- Kinn, D.N. 1980. Mutualism between *Dendrolaelaps neodisetus* and *Dendroctonus frontalis*. *Environmental Entomology* 9:756–758.

- Kinney, K.K., R.L. Lindroth, S.M. Jung, and E.V. Nordheim. 1997. Effects of CO<sub>2</sub> and NO<sub>3</sub><sup>-</sup> availability on deciduous trees: phytochemistry and insect performance. *Ecology* 78:215–230.
- Kinyamario, J.I., and S.K. Imbamba. 1992. Savanna at Nairobi National Park, Nairobi. In *Primary Productivity of Grass Ecosystems of the Tropics and Subtropics* (S.P. Long, M.B. Jones, and M.J. Roberts, Eds.), pp. 25–69. Chapman and Hall, London, UK.
- Kishtawal, C.M., D. Niyogi, M. Tewari, R.A. Pielke, Sr., and J.M. Shepherd. 2010. Urbanization signature in the observed heavy rainfall climatology over India. *International Journal of Climatology* 30:1908–1916.
- Kitchell, J.F., R.V. O'Neill, D. Webb, G.W. Gallepp, S.M. Bartell, J.F. Koonce, and B.S. Ausmus. 1979. Consumer regulation of nutrient cycling. *BioScience* 29:28–34.
- Kitching, R.L., J.M. Bergelson, M.D. Lowman, S. McIntyre, and G. Carruthers. 1993. The biodiversity of arthropods from Australian rainforest canopies: general introduction, methods, sites and ordinal results. *Australian Journal of Ecology* 18:181–191.
- Kizilinski, M.L., D.A. Orwig, R.C. Cobb, and D.R. Foster. 2002. Direct and indirect ecosystem consequences of an invasive pest on forests dominated by eastern hemlock. *Journal of Biogeography* 29:1489–1503.
- Klapwijk, M.J., B.C. Gröbler, K. Ward, D. Wheeler, and O.T. Lewis. 2010. Influence of experimental warming and shading on host–parasitoid synchrony. *Global Change Biology* 16:102–112.
- Klein, A.-M., I. Steffan-Dewenter, and T. Tscharnkte. 2003. Fruit set of highland coffee increases with the diversity of pollinating bees. *Proceedings of the Royal Society of London B* 270:955–961.
- Klein, A.-M., B.E. Vaissière, J.H. Cane, I. Steffan-Dewenter, S.A. Cunningham, C. Kremen, and T. Tscharnkte. 2007. Importance of pollinators in changing landscapes for world crops. *Proceedings of the Royal Society B* 274:303–313.
- Klein, B.C. 1989. Effects of forest fragmentation on dung and carrion beetle communities in central Amazonia. *Ecology* 70:1715–1725.
- Klepzig, K.D., E.B. Smalley, and K.F. Raffa. 1996. Combined chemical defenses against an insect–fungal complex. *Journal of Chemical Ecology* 22:1367–1388.
- Klock, G.O., and B.E. Wickman. 1978. Ecosystem effects. In *The Douglas-fir Tussock Moth: a Synthesis* (M.H. Brookes, R.W. Stark, and R.W. Campbell, Eds.), pp. 90–95. USDA Forest Service, Tech. Bull. 1585, USDA Forest Service, Washington, DC.
- Kluth, S., A. Kruess, and T. Tscharnkte. 2002. Insects as vectors of plant pathogens: mutualistic and antagonistic interactions. *Oecologia* 133:193–199.
- Knapp, A.K., and T.R. Seastedt. 1986. Detritus accumulation limits productivity of tallgrass prairie. *BioScience* 36:662–668.
- Knight, T.M., and R.D. Holt. 2005. Fire generates spatial gradients in herbivory: an example from a Florida sandhill ecosystem. *Ecology* 86:587–593.
- Knight, T.M., M.W. McCoy, J.M. Chase, K.A. McCoy, and R.D. Holt. 2005a. Trophic cascades across ecosystems. *Nature* 437:880–883.
- Knight, T.M., J.A. Steets, J.A. Vamosi, S.J. Mazer, M. Burd, D.R. Campbell, M.R. Dudash, M.O. Johnston, R.J. Mitchell, and T.-L. Ashman. 2005b. Pollen limitation of plant reproduction: pattern and process. *Annual Review of Ecology, Evolution and Systematics* 36:467–497.
- Knops, J.M.H., D. Tilman, N.M. Haddad, S. Naeem, C.E. Mitchell, J. Haarstad, M.E. Ritchie, K.M. Howe, P.B. Reich, E. Siemann, and J. Groth. 1999. Effects of plant species richness on invasion dynamics, disease outbreaks, insect abundances and diversity. *Ecology Letters* 2:286–293.
- Knorr, M., S.D. Frey, and P.S. Curtis. 2005. Nitrogen additions and litter decomposition: a meta-analysis. *Ecology* 85:3252–3257.
- Koenig, W.D., and A.M. Liebhold. 2005. Effects of periodical cicada emergences on abundances and synchrony of avian populations. *Ecology* 86:1873–1882.
- Kogan, M. 1975. Plant resistance in pest management. In *Introduction to Insect Pest Management* (R.L. Metcalf, and W.H. Luckmann, Eds.), pp. 103–146. Wiley, New York, NY.
- Kogan, M. 1981. Dynamics of insect adaptations to soybean: impact of integrated pest management. *Environmental Entomology* 10:363–371.
- Kogan, M. 1998. Integrated pest management: historical perspectives and contemporary developments. *Annual Review of Entomology* 43:243–270.
- Kogan, M., and P. Jepson (Eds.) 2007. Perspectives in Ecological Theory and Integrated Pest Management. Cambridge University Press, Cambridge, UK.
- Kogan, M., and J. Paxton. 1983. Natural inducers of plant resistance to insects. In *Plant Resistance to Insects* (P.A. Hedin, Ed.), pp. 153–170. ACS Symposium Series 208, American Chemical Society, Washington, DC.
- Kogan, M., and S.G. Turnipseed. 1987. Ecology and management of soybean arthropods. *Annual Review of Entomology* 32:507–538.
- Kohlmann, B. 1991. Dung beetles in subtropical North America. In *Dung Beetle Ecology* (I. Hanski, and Y. Cambefort, Eds.), pp. 116–132. Princeton University Press, Princeton, NJ.
- Kohn, J.R., and B.B. Casper. 1992. Pollen-mediated gene flow in *Cucurbita foetidissima* (Cucurbitaceae). *American Journal of Botany* 79:57–62.
- Kolb, T.E., K.A. Dodds, and K.M. Clancy. 1999. Effect of western spruce budworm defoliation on the physiology and growth of potted Douglas-fir seedlings. *Forest Science* 45:280–291.
- Kolb, T.E., K.M. Holmberg, M.R. Wagner, and J.E. Stone. 1998. Regulation of ponderosa pine foliar

- physiology and insect resistance mechanisms by basal area treatments. *Tree Physiology* 18:375–381.
- Konishi, M., and Y. Itô. 1973. Early entomology in East Asia. In *History of Entomology* (R.F. Smith, T.E. Mittler, and C.N. Smith, Eds.), pp. 1–20. Annual Reviews Inc, Palo Alto, CA.
- Koptur, S., M.C. Rodriguez, S.F. Oberbauer, C. Weekley, and A. Herndon. 2002. Herbivore-free time? Damage to new leaves of woody plants after Hurricane Andrew. *Biotropica* 34:547–554.
- Koren, I., Y.J. Kaufman, L.A. Remer, and J.V. Martins. 2004. Measurement of the effect of Amazon smoke on inhibition of cloud formation. *Science* 303:1342–1345.
- Koricheva, J. 2002. Meta-analysis of sources of variation in fitness costs of plant antiherbivore defenses. *Ecology* 83:176–190.
- Koricheva, J., S. Larsson, and E. Haukioja. 1998. Insect performance on experimentally stressed woody plants: a meta-analysis. *Annual Review of Entomology* 43:195–216.
- Koricheva, J., C.P.H. Mulder, B.Schmid, J. Joshi and K. Huss-Danell. 2000. Numerical responses of different trophic groups of invertebrates.
- Körner, C. 1993. Scaling from species to vegetation: the usefulness of functional groups. In *Biodiversity and Ecosystem Function* (E.D. Schulze, and H.A. Mooney, Eds.), pp. 117–140. Springer-Verlag, Berlin, Germany.
- Koyama, J., H. Kakinohana, and T. Miyatake. 2004. Eradication of the melon fly, *Bactrocera cucurbitae*, in Japan: importance of behavior, ecology, genetics, and evolution. *Annual Review of Entomology* 49:331–349.
- Koyama, Y., I. Yao, and S.-I. Akimoto. 2004. Aphid galls accumulate high concentrations of amino acids: a support for the nutrition hypothesis for gall formation. *Entomologia Experimentalis et Applicata* 113:35–44.
- Kozár, F. 1991. Recent changes in the distribution of insects and the global warming. In *Proc. 4<sup>th</sup> European Congress of Entomology, Gödöllő, Hungary*, pp. 406–413.
- Kozár, F. 1992a. Organization of arthropod communities in agroecosystems. *Acta Phytopathologica et Entomologica Hungarica* 27:365–373.
- Kozár, F. 1992b. Resource partitioning of host plants by insects on a geographic scale. In *Proc. 8<sup>th</sup> International Symposium on Insect-plant Relationships* (S.B.J. Menken, J.H. Visser, and P. Harrewijn, Eds.), pp. 46–48. Kluwer Academic Publ, Dordrecht, The Netherlands.
- Krafft, C.C., and S.N. Handel. 1991. The role of carnivory in the growth and reproduction of *Drosera filiformis* and *D. rotundifolia*. *Bulletin of the Torrey Botanical Club* 118:12–19.
- Kramer, A.M., B. Dennis, A.M. Liebhold, and J.M. Drake. 2009. The evidence for Allee effects. *Population Ecology* 51:341–354.
- Kranthi, K.R., S. Naidu, C.S. Dhawad, A. Tatwawadi, K. Mate, E. Patil, A.A. Bharose, G.T. Behare, R.M. Wadaskar, and S. Kranthi. 2005. Temporal and intraplant variability in Cry1Ac expression in Bt cotton and its influence on the survival of the cotton bollworm, *Helicoverpa armigera* (Hübner) (Noctuidae: Lepidoptera). *Current Science* 89:291–298.
- Krantz, G.W. 1978. A Manual of Acarology. Oregon State University Book Stores, Corvallis, OR.
- Krantz, G.W., and J.L. Mellott. 1972. Studies on phoretic specificity in *Macrocheles mycotropetes* and *M. peliotrupetes* Krantz and Mellott (Acari: Macrochelidae), associates of geotrupine Scarabaeidae. *Acarologia* 14:317–344.
- Kratz, T.K., J.J. Magnuson, P. Bayley, B.J. Benson, C.W. Berish, C.S. Bledsoe, E.R. Blood, C.J. Bowser, S.R. Carpenter, G.L. Cunningham, R.A. Dahlgren, T.M. Frost, J.C. Halfpenny, J.D. Hansen, D. Heisey, R.S. Inouye, D.W. Kaufman, A. McKee, and J. Yarie. 1995. Temporal and spatial variability as neglected ecosystem properties: lessons learned from 12 North American ecosystems. In *Evaluating and Monitoring the Health of Large-scale Ecosystems* (D.J. Rapport, C.L. Gaudet, and P. Calow, Eds.), pp. 359–383. NATO ASI Series, Vol. 128. Springer-Verlag, Berlin, Germany.
- Krawchuk, M.A., and P.D. Taylor. 2003. Changing importance of habitat structure across multiple spatial scales for three species of insects. *Oikos* 103:153–161.
- Kremen, C. 2005. Managing ecosystem services: what do we need to know about their ecology? *Ecology Letters* 8:468–479.
- Kremen, C., N.M. Williams, and R.W. Thorp. 2002. Crop pollination from native bees as risk from agricultural intensification. *Proceedings of the National Academy of Science, USA* 99:16812–16816.
- Kremen, C., N.M. Williams, R.L. Bugg, J.P. Fay, and R.W. Thorp. 2004. The area requirements of an ecosystem service: crop pollination by native bee communities in California. *Ecology Letters* 7:1109–1119.
- Kremen, C., N.M. Williams, M.A. Aizen, B. Gemmill-Herren, G. LeBuhn, R. Minckley, L. Packer, S.G. Potts, T. Roulston, I. Steffan-Dewenter, D.P. Vázquez, R. Winfree, L. Adams, E.E. Crone, S.S. Greenleaf, T.H. Keitt, A.-M. Klein, J. Regetz, and T.H. Ricketts. 2007. Pollination and other ecosystem services produced by mobile organisms: a conceptual framework for the effects of land-use change. *Ecology Letters* 10:299–314.
- Kriska, G., Z. Csabai, P. Boda, P. Malik, and G. Horváth. 2006. Why do red and dark-coloured cars lure aquatic insects? The attraction of water insects to car paintwork explained by reflection-polarization signals. *Proceedings of the Royal Society B* 273:1667–1671.
- Kruess, A., and T. Tscharnke. 1994. Habitat fragmentation, species loss, and biological control. *Science* 264:1581–1584.

- Kruess, A., and T. Tschardt. 2000. Species richness and parasitism in a fragmented landscape: experiments and field studies with insects on *Vicia sepium*. *Oecologia* 122:129–137.
- Krug, E.C. 2007. Coastal change and hypoxia in the northern Gulf of Mexico. Part 1. *Hydrology and Earth System Sciences* 11:180–190.
- Kruger, M., J.B.J. Van Rensburg, and J. van den Berg. 2008. Perspective on the development of stem borer resistance to Bt maize and refuge compliance at the Vaalharts irrigation scheme in South Africa. *Crop Protection* 28:684–689.
- Kudo, G., T.Y. Ida, and T. Tani. 2008. Linkages between phenology, pollination, photosynthesis, and reproduction in deciduous forest understory plants. *Ecology* 89:321–331.
- Kurokawa, H., and T. Nakashizuka. 2008. Leaf herbivory and decomposability in a Malaysian tropical rain forest. *Ecology* 89:2645–2656.
- Kursar, T.A., T.L. Capson, P.D. Coley, D.G. Corley, L.B. Gupta, L.A. Harrison, E. Ortega-Barria, and D.M. Windsor. 1999. Ecologically guided bio-prospecting in Panama. *Pharmaceutical Biology* 37:114–126.
- Kurz, W.A., C.C. Dymond, G. Stinson, G.J. Rampley, E.T. Neilson, A.L. Carroll, T. Ebata, and L. Safranyik. 2008. Mountain pine beetle and forest carbon feedback to climate change. *Nature* 452:987–990.
- Kytö, M., P. Niemelä, and S. Larsson. 1996. Insects on trees: population and individual response to fertilization. *Oikos* 75:148–159.
- Laakso, J., and H. Setälä. 1999. Sensitivity of primary production to changes in the architecture of below-ground food webs. *Oikos* 87:57–64.
- Labandeira, C.C. 1998. Early history of arthropod and vascular plant associations. *Annual Review of Earth and Planetary Science* 26:329–377.
- Labandeira, C.C. 2002. The history of associations between plants and animals. In *Plant–Animal Interactions: an Evolutionary Approach* (C.M. Herrera, and O. Pellmyr, Eds.), pp. 26–74. Blackwell, London, UK.
- Labandeira, C.C., and J.J. Sepkoski, Jr. 1993. Insect diversity in the fossil record. *Science* 261:310–315.
- Labandeira, C.C., B.A. LePage, and A.H. Johnson. 2001. A *Dendroctonus* bark engraving (Coleoptera: Scolytidae) from a Middle Eocene *Larix* (Coniferales: Pinaceae): early or delayed colonization. *American Journal of Botany* 88:2026–2039.
- Labandeira, C.C., K.R. Johnson, and P. Wilf. 2002. Impact of the terminal Cretaceous event on plant–insect associations. *Proceedings of the National Academy of Sciences, USA* 99:2061–2066.
- LaDeau, S.L., A.M. Kilpatrick, and P.P. Marra. 2007. West Nile virus emergence and large-scale declines of North American bird populations. *Nature* 447:710–713.
- LaDeau, S.L., P.P. Marra, A.M. Kilpatrick, and C.A. Calder. 2008. West Nile virus revisited: consequences for North American ecology. *BioScience* 58:937–946.
- Lai, L.-C., R.-N. Huang, and W.-J. Wu. 2008. Venom alkaloids of monogyne and polygyne forms of the red imported fire ant, *Solenopsis invicta*, in Taiwan. *Insectes Sociaux* 55:443–449.
- Lake, P.S., N. Bond, and P. Reich. 2007. Linking ecological theory with stream restoration. *Freshwater Biology* 52:597–615.
- Lambeets, K., M.L. Vendegehuchte, J.-P. Maelfait, and D. Bonte. 2008. Understanding the impact of flooding on trait-displacements and shifts in assemblage structure of predatory arthropods on river banks. *Journal of Animal Ecology* 77:1162–1174.
- Lanciotti, R.S., J.T. Roehrig, V. Deubel, J. Smith, M. Parker, K. Steele, B. Crise, K.E. Volpe, M.B. Crabtree, J.H. Scherret, R.A. Hall, J.S. MacKenzie, C.B. Cropp, B. Panigrahy, E. Ostlund, B. Schmitt, M. Malkinson, C. Banet, J. Weissman, N. Komar, H.M. Savage, W. Stone, T. McNamara, and D.J. Gubler. 1999. Origin of the West Nile virus responsible for an outbreak of encephalitis in the northeastern United States. *Science* 286:2333–2337.
- Landis, D.A., S.D. Wratten, and G.M. Gurr. 2000. Habitat management to conserve natural enemies of arthropod pests in agriculture. *Annual Review of Entomology* 45:175–201.
- Landis, D.A., F.D. Menalled, A.C. Costamagna, and T.K. Wilkinson. 2005. Manipulating plant resources to enhance beneficial arthropods in agricultural landscapes. *Weed Science* 53:902–908.
- Landsberg, J. 1989. A comparison of methods for assessing defoliation, tested on eucalypt trees. *Australian Journal of Ecology* 14:423–440.
- Landsberg, J., and C. Ohmart. 1989. Levels of insect defoliation in forests: patterns and concepts. *Trends in Ecology and Evolution* 4:96–100.
- Larsen, T.H., N.M. Williams, and C. Kremen. 2005. Extinction order and altered community structure rapidly disrupt ecosystem functioning. *Ecology Letters* 8:538–547.
- Larsson, S., C. Bjorkman, and N.A.C. Kidd. 1993. Outbreaks in diprionid sawflies: why some species and not others? In *Sawfly Life History Adaptations to Woody Plants* (M.R. Wagner, and K.F. Raffa, Eds.), pp. 453–483. Academic Press, San Diego, CA.
- Laskowski, R., M. Niklińska, and M. Maryński. 1995. The dynamics of chemical elements in forest litter. *Ecology* 76:1393–1406.
- Lavigne, R., R. Kumar, and J.A. Scott. 1991. Additions to the Pawnee National Grasslands insect checklist. *Entomological News* 102:150–164.
- Law, J.M., and F.E. Regnier. 1971. Pheromones. *Annual Review of Biochemistry* 40:533–548.
- Lawrence, R.K., W.J. Mattson, and R.A. Haack. 1997. White spruce and the spruce budworm: defining the phenological window of susceptibility. *Canadian Entomologist* 129:291–318.

- Lawrence, W.T., Jr. 1996. Plants: the food base. In *The Food Web of a Tropical Rain Forest* (D.P. Reagan, and R.B. Waide, Eds.), pp. 17–51. University of Chicago Press, Chicago, IL.
- Lawton, J.H. 1982. Vacant niches and unsaturated communities: a comparison of bracken herbivores at sites on two continents. *Journal of Animal Ecology* 51:573–595.
- Lawton, J.H. 1983. Plant architecture and the diversity of phytophagous insects. *Annual Review of Entomology* 28:23–39.
- Lawton, J.H. 1995. Response of insects to environmental change. In *Insects in a Changing Environment* (R. Harrington, and N.E. Stork, Eds.), pp. 5–26. Academic Press, London, UK.
- Lawton, J.H., and V.K. Brown. 1993. Redundancy in ecosystems. In *Biodiversity and Ecosystem Function* (E.D. Schulze, and M.A. Mooney, Eds.), pp. 255–270. Springer-Verlag, Berlin, Germany.
- Lawton, J.H., and D.R. Strong. 1981. Community patterns and competition in folivorous insects. *American Naturalist* 118:317–338.
- Leather, S.R. (Ed.) 2005. *Insect Sampling in Forest Ecosystems*. Blackwell Science, Malden, MA.
- Lee, K.E., and J.H.A. Butler. 1977. Termites, soil organic matter decomposition and nutrient cycling. *Ecological Bulletin (Stockholm)* 25:544–548.
- Lee, K.P., S.T. Behmer, S.J. Simpson, and D. Raubenheimer. 2002. A geometric analysis of nutrient regulation in the generalist caterpillar *Spodoptera littoralis* (Boisduval). *Journal of Insect Physiology* 48:655–665.
- Lee, K.P., D. Raubenheimer, S.T. Behmer, and S.J. Simpson. 2003. A correlation between macronutrient balancing and insect host-plant range: evidence from the specialist caterpillar *Spodoptera exempta* (Walker). *Journal of Insect Physiology* 49:1161–1171.
- Lee, K.Y., F.M. Horodyski, A.P. Valaitis, and D.L. Denlinger. 2002. Molecular characterization of the insect immune protein hemolin and its high induction during embryonic diapause in the gypsy moth, *Lymantria dispar*. *Insect Biochemistry and Molecular Biology* 32:1457–1467.
- Le Goff, G., S. Boundy, P.J. Daborn, J.L. Yen, L. Sofer, R. Lind, C. Sabourault, L. Madi-Ravazzi, and R.H. Ffrench-Constant. 2003. Microarray analysis of cytochrome P450 mediated insecticide resistance in *Drosophila*. *Insect Biochemistry and Molecular Biology* 33:701–708.
- Leibold, M.A., and G.M. Mikkelsen. 2002. Coherence, species turnover, and boundary clumping: elements of meta-community structure. *Oikos* 97:237–250.
- Leigh, E.G., and N. Smythe. 1978. Leaf production, leaf consumption and the regulation of folivory on Barro Colorado Island. In *The Ecology of Arboreal Folivores* (E.G. Leigh, A.S. Rand, and D.M. Windsor, Eds.), pp. 33–50. Smithsonian Institution Press, Washington, DC.
- Leigh, E.G., and D.M. Windsor. 1982. Forest production and regulation of primary consumers on Barro Colorado Island. In *The Ecology of Arboreal Folivores* (E.G. Leigh, A.S. Rand, and D.M. Windsor, Eds.), pp. 109–123. Smithsonian Institution Press, Washington, DC.
- Leisnham, P.T., and I.G. Jamieson. 2002. Metapopulation dynamics of a flightless alpine insect *Hemideina maori* in a naturally fragmented habitat. *Ecological Entomology* 27:574–580.
- le Mellec, A., M. Habermann, and B. Michalzik. 2009. Canopy herbivory altering C to N ratios and soil input patterns of different organic matter fractions in a Scots pine forest. *Plant and Soil* 325:255–262.
- Lenoir, L., T. Persson, and J. Bengtsson. 2001. Wood ant nests as potential hot spots for carbon and nitrogen mineralization. *Biology and Fertility of Soils* 34:235–240.
- Lent, D.D., P. Graham, and T.S. Collett. 2009. A motor component to the memories of habitual foraging routes in wood ants? *Current Biology* 19: 115–121.
- Leonard, D.E. 1970. Intrinsic factors causing qualitative changes in populations of *Porthetria dispar* (Lepidoptera: Lymantriidae). *Canadian Entomologist* 102:239–249.
- Lerdau, M., A. Guenther, and R. Monson. 1997. Plant production and emission of volatile organic compounds. *BioScience* 47:373–383.
- Leroux, S.J., and M. Loreau. 2008. Subsidy hypothesis and strength of trophic cascades across ecosystems. *Ecology Letters* 11:1147–1156.
- Lesica, P., and P.B. Kannonowski. 1998. Ants create hummocks and alter structure and vegetation of a Montana fen. *American Midland Naturalist* 139:58–68.
- Letourneau, D.K., and L.A. Dyer. 1998. Density patterns of *Piper* ant-plants and associated arthropods: top-predator trophic cascades in a terrestrial system? *Biotropica* 30:162–169.
- Letourneau, D.K., J.A. Jedlicka, S.G. Bothwell, and C.R. Moreno. 2009. Effects of natural enemy biodiversity on the suppression of arthropod herbivores in terrestrial ecosystems. *Annual Review of Ecology, Evolution and Systematics* 40:573–592.
- Leuschner, W.A. 1980. Impacts of the southern pine beetle. In *The Southern Pine Beetle* (R.C. Thatcher, J.L. Searcy, J.E. Coster, and G.D. Hertel, Eds.), pp. 137–151. USDA Forest Service Technical Bulletin 1631. USDA Forest Service, Washington, DC.
- Levins, R. 1970. Extinction. *Lectures on Mathematics in the Life Sciences* 2:77–107.
- Lewinsohn, T.M., and P.W. Price. 1996. Diversity of herbivorous insects and ecosystem processes. In *Biodiversity and Savanna Ecosystem Processes* (O.T. Solbrig, E. Medina, and J.F. Silva, Eds.), pp. 143–157. Springer-Verlag, Berlin, Germany.
- Lewinsohn, T.M., and T. Roslin. 2008. Four ways toward tropical herbivore megadiversity. *Ecology Letters* 11:398–416.

- Lewis, A.C. 1979. Feeding preference for diseased and wilted sunflower in the grasshopper, *Melanoplus differentialis*. *Entomologia Experimentalis et Applicata* 26:202–207.
- Lewis, A.C. 1986. Memory constraints and flower choice in *Pteris rapae*. *Science* 232:863–865.
- Lewis, A.C. 1993. Learning and the evolution of resources: pollinators and flower morphology. In *Insect Learning: Ecological and Evolutionary Perspectives* (D.R. Papaj, and A.C. Lewis, Eds.), pp. 219–242. Chapman & Hall, New York, NY.
- Lewis, O.T., and S. Gripenberg. 2008. Insect seed predators and environmental change. *Journal of Applied Ecology* 45:1593–1599.
- Lewis, T. 1998. The effect of deforestation on ground surface temperatures. *Global and Planetary Change* 18:1–13.
- Lewis, W.J., and J.H. Tumlinson. 1988. Host detection by chemically mediated associative learning in a parasitic wasp. *Nature* 331:257–259.
- Li, Y.-H., and S.-S. Liu. 2004. Learning in phytophagous insects. *Acta Entomologica Sinica* 47:106–116 in Chinese with English summary.
- Liang, D., A. Zhang, R.J. Kopanic, Jr., W.L. Roelofs, and C. Schal. 1998. Field and laboratory evaluation of the female sex pheromone for detection, monitoring and management of brownbanded cockroaches (Dictyoptera: Blattellidae). *Journal of Economic Entomology* 91:480–485.
- Liebhold, A.M., and J.S. Elkinton. 1989. Characterizing spatial patterns of gypsy moth regional defoliation. *Forest Science* 35:557–568.
- Liebhold, A.M., J.A. Halverson, and G.A. Elmes. 1992. Gypsy moth invasion of North America: a quantitative analysis. *Journal of Biogeography* 19:513–520.
- Liebhold, A.M., R.E. Rossi, and W.P. Kemp. 1993. Geostatistics and geographic information systems in applied insect ecology. *Annual Review of Entomology* 38:303–327.
- Liebhold, A., W.D. Koenig, and O.N. Bjørnstad. 2004. Spatial synchrony in population dynamics. *Annual Review of Ecology, Evolution and Systematics* 35:467–490.
- Liebhold, A., D.M. Johnson, and O.N. Bjørnstad. 2006. Geographic variation in density-dependent dynamics impacts the synchronizing effect of dispersal and regional stochasticity. *Population Ecology* 48:131–138.
- Lill, J.T., and R.J. Marquis. 2001. The effects of leaf quality on herbivore performance and attack from natural enemies. *Oecologia* 126:418–428.
- Lincoln, D.E., E.D. Fajer, and R.H. Johnson. 1993. Plant–insect herbivore interactions in elevated CO<sub>2</sub> environments. *Trends in Ecology and Evolution* 8:64–68.
- Lindeman, R.L. 1942. The trophic-dynamic aspect of ecology. *Ecology* 23:399–418.
- Lindo, Z., and N.N. Winchester. 2007. Oribatid mite communities and foliar litter decomposition in canopy suspended soils and forest floor habitats of western redcedar forests, Vancouver Island, Canada. *Soil Biology and Biochemistry* 39:2957–2966.
- Lindroth, R.L., M.A. Barman, and A.V. Weisbrod. 1991. Nutrient deficiencies and the gypsy moth, *Lymantria dispar*: effects of larval performance and detoxification enzyme activity. *Journal of Insect Physiology* 37:45–52.
- Linley, J.R. 1966. The ovarian cycle of *Culicoides barbosai* Wirth & Blanton and *C. furens* (Poey) (Ceratopogonidae). *Bulletin of Entomological Research* 57:1–17.
- Little, D., C. Gouhier-Darimont, F. Bruessow, and P. Reymond. 2007. Oviposition by pierid butterflies triggers defense responses in Arabidopsis. *Plant Physiology* 143:784–800.
- Liu, Z.G., and X.M. Zou. 2002. Exotic earthworms accelerate plant litter decomposition in a Puerto Rican pasture and a wet forest. *Ecological Applications* 12:1406–1417.
- Llewellyn, D., C. Tyson, G. Constable, B. Duggan, S. Beale, and P. Steel. 2007. Containment of regulated genetically modified cotton in the field. *Agriculture, Ecosystems and Environment* 121:419–429.
- Llewellyn, M. 1972. The effects of the lime aphid, *Eucallipterus tiliae* L. (Aphididae) on the growth of the lime, *Tilia x vulgaris* Hayne. *Journal of Applied Ecology* 9:261–282.
- Lloyd, J.E. 1983. Bioluminescence and communication in insects. *Annual Review of Entomology* 28:131–160.
- Lockwood, J.A. 2001. Voices from the past: what we can learn from the Rocky Mountain locust. *American Entomologist* 47:208–215.
- Lockwood, J.A. 2008. Six legged soldiers: using insects as weapons of war. Oxford University Press, New York, NY.
- Lockwood, J.A., and L.D. DeBrey. 1990. A solution for the sudden and unexplained extinction of the Rocky Mountain grasshopper (Orthoptera: Acrididae). *Environmental Entomology* 19:1194–1205.
- Lodge, D.J., W.H. McDowell, J. Macy, S.K. Ward, R. Leisso, K. Claudio-Campos, and K. Kuhnert. 2008. Distribution and role of mat-forming saprobic basidiomycetes in a tropical forest. In *Ecology of Saprobiic Basidiomycetes* (L. Boddy, and J.C. Frankland, Eds.), pp. 195–208. Elsevier/Academic, Amsterdam, The Netherlands.
- Logan, J.A., and J.C. Allen. 1992. Nonlinear dynamics and chaos in insect populations. *Annual Review of Entomology* 37:455–477.
- Logan, J.A., J. Régnière, and J.A. Powell. 2003. Assessing the impacts of global warming on forest pest dynamics. *Frontiers in Ecology and the Environment* 1:130–137.
- Logan, J.D., W. Wolessensky, and A. Joern. 2006. Temperature-dependent phenology and predation in arthropod systems. *Ecological Modelling* 196:471–482.

- Logan, J.G., N.J. Seal, J.I. Cook, N.M. Stanczyk, M.A. Birkett, S.J. Clark, S.A. Gezan, L.J. Wadhams, J.A. Pickett, and A.J. Mordue (Luntz). 2009. Identification of human-derived volatile chemicals that interfere with attraction of the Scottish biting midge and their potential use as repellents. *Journal of Medical Entomology* 46:208–219.
- Loomis, W.E. 1932. Growth-differentiation balance vs. carbohydrate–nitrogen ratio. *Proceedings of the American Society for Horticultural Science* 29:240–245.
- Lorch, P.D., G.A. Sword, D.T. Gwynne, and G.L. Anderson. 2005. Radiotelemetry reveals differences in individual movement patterns between outbreak and non-outbreak Mormon cricket populations. *Ecological Entomology* 30:548–555.
- Loreau, M. 1995. Consumers as maximizers of matter and energy flow in ecosystems. *American Naturalist* 145:22–42.
- Loreau, M., and C. de Mazancourt. 2008. Species synchrony and its drivers: neutral and nonneutral community dynamics in fluctuating environments. *American Naturalist* 172:E48–E66.
- Lorio, Jr., P.L. 1993. Environmental stress and whole-tree physiology. In *Beetle–pathogen Interactions in Conifer Forests* (T.D. Schowalter, and G.M. Filip, Eds.), pp. 81–101. Academic Press, London, UK.
- Losey, J.E., and M. Vaughn. 2006. The economic value of ecological services provided by insects. *BioScience* 56:311–323.
- Losey, J.E., L.S. Rayor, and M.E. Carter. 1999. Transgenic pollen harms monarch larvae. *Nature* 399:214.
- Lotka, A.J. 1925. *Elements of Physical Biology*. Williams and Wilkins, Baltimore, MD.
- Lou, Y., and J. Cheng. 1997. Induced plant resistance to phytophagous insects. *Acta Entomologica Sinica* 40:320–331 in Chinese with English summary.
- Louda, S.M. 1982. Inflorescence spiders: a cost/benefit analysis for the host plant, *Haplopappus venetus* Blake (Asteraceae). *Oecologia* 55:185–191.
- Louda, S.M., and J.E. Rodman. 1996. Insect herbivory as a major factor in the shade distribution of a native crucifer (*Cardamine cordifolia* A. Gray, bitter-cress). *Journal of Ecology* 84:229–237.
- Louda, S.M., K.H. Keeler, and R.D. Holt. 1990a. Herbivore influences on plant performance and competitive interactions. In *Perspectives on Plant Competition* (J.B. Grace, and D. Tilman, Eds.), pp. 413–444. Academic Press, San Diego, CA.
- Louda, S.M., M.A. Potvin, and S.K. Collinge. 1990b. Predispersal seed predation, postdispersal seed predation and competition in the recruitment of seedlings of a native thistle in sandhills prairie. *American Midland Naturalist* 124:105–113.
- Louda, S.M., R.W. Pemberton, M.T. Johnson, and P.A. Follett. 2003. Non-target effects—the Achilles' heel of biocontrol? Retrospective analyses to assess risk associated with biocontrol introductions. *Annual Review of Entomology* 48:365–396.
- Lounibos, L.P., G.F. O'Meara, N. Nishimura, and R.L. Escher. 2003. Interactions with native mosquito larvae regulate the production of *Aedes albopictus* from bromeliads in Florida. *Ecological Entomology* 28:551–558.
- Lovelock, C.E., J. Posada, and K. Winter. 1999. Effects of elevated CO<sub>2</sub> and defoliation on compensatory growth and photosynthesis of seedlings in a tropical tree, *Copaifera aromatica*. *Biotropica* 31:279–287.
- Lovelock, J. 1988. *The Ages of Gaia*. W.W. Norton, New York, NY.
- Lovett, G.M., and A.E. Ruesink. 1995. Carbon and nitrogen mineralization from decomposing gypsy moth frass. *Oecologia* 104:133–138.
- Lovett, G., and P. Tobiesen. 1993. Carbon and nitrogen assimilation in red oaks (*Quercus rubra* L.) subject to defoliation and nitrogen stress. *Tree Physiology* 12:259–269.
- Lovett, G.M., S.S. Nolan, C.T. Driscoll, and T.J. Fahey. 1996. Factors regulating throughfall flux in a New Hampshire forested landscape. *Canadian Journal of Forest Research* 26:2134–2144.
- Lovett, G.M., L.M. Christenson, P.M. Groffman, C.G. Jones, J.E. Hart, and M.J. Mitchell. 2002. Insect defoliation and nitrogen cycling in forests. *BioScience* 52:335–341.
- Lowman, M.D. 1982. The effects of different rates and methods of leaf area removal on coachwood (*Ceratopetalum apetalum*). *Australian Journal of Botany* 30:477–483.
- Lowman, M.D. 1984. An assessment of techniques for measuring herbivory: is rainforest defoliation more intense than we thought? *Biotropica* 16:264–268.
- Lowman, M.D. 1985. Spatial and temporal variability in herbivory of Australian rain forest canopies. *Australian Journal of Ecology* 10:7–14.
- Lowman, M.D. 1992. Leaf growth dynamics and herbivory in five species of Australian rain forest canopy trees. *Journal of Ecology* 80:433–447.
- Lowman, M.D. 1995. Herbivory as a canopy process in rain forest trees. In *Forest Canopies* (M.D. Lowman, and N.M. Nadkarni, Eds.), pp. 431–455. Academic Press, San Diego, CA.
- Lowman, M.D., and J.H. Box. 1983. Variation in leaf toughness and phenolic content among 5 species of Australia rain forest trees. *Australian Journal of Ecology* 8:17–25.
- Lowman, M.D., and H.H. Heatwole. 1992. Spatial and temporal variability in defoliation of Australian eucalypts. *Ecology* 73:129–142.
- Lowman, M.D., M. Moffett, and H.B. Rinker. 1993. A technique for taxonomic and ecological sampling in rain forest canopies. *Selbyana* 14:75–79.
- Lowrance, R., B.R., Stinner, and G.J., House (Eds.) 1984. *Agricultural Ecosystems: Unifying Concepts*. Wiley, New York, NY.



- Lubchenco, J. 1978. Plant species diversity in a marine intertidal community: importance of herbivore food preference and algal competitive abilities. *American Naturalist* 112:23–39.
- Lugo, A.E. 2004. The outcome of alien tree invasions in Puerto Rico. *Frontiers in Ecology and the Environment* 2:265–273.
- Lugo, A.E., and H. Gucinski. 2000. Function, effects, and management of forest roads. *Forest Ecology and Management* 133:249–262.
- Luh, H.-K., and B.A. Croft. 1999. Classification of generalist or specialist life styles of predaceous phytoseiid mites using a computer genetic algorithm, information theory, and life history traits. *Environmental Entomology* 28:915–923.
- Lunderstädt, J. 1981. The role of food as a density-determining factor for phytophagous insects with reference to the relationship between Norway spruce (*Picea abies* Karst) and *Gilpinia hercyniae* Htg. (Hymenoptera, Diprionidae). *Forest Ecology and Management* 3:335–353.
- Lundheim, R., and K.E. Zachariassen. 1993. Water balance of over-wintering beetles in relation to strategies for cold tolerance. *Journal of Comparative Physiology B* 163:1–4.
- Lüscher, M. 1961. Air-conditioned termite nests. *Scientific American* 205:138–145.
- Lynch, H.J., R.A. Renkin, R.L. Crabtree, and P.R. Moorcroft. 2006. The influence of previous mountain pine beetle (*Dendroctonus ponderosae*) activity on the 1988 Yellowstone fires. *Ecosystems* 9:1318–1327.
- Lyytikäinen-Saarenmaa, P. 1999. Growth responses of Scots pine (Pinaceae) to artificial and sawfly (Hymenoptera: Diprionidae) defoliation. *Canadian Entomologist* 131:455–463.
- Ma, S.-C. 1958. The population dynamics of the oriental migratory locust (*Locusta migratoria manilensis* Mayen) in China. *Acta Entomologica Sinica* 8:1–40 in Chinese with English summary.
- MacArthur, R.H., and E.O. Wilson. 1967. *The Theory of Island Biogeography*. Princeton University Press, Princeton, NJ.
- Macaulay, B.J. 1975. Biodegradation of litter in *Eucalyptus pauciflora* communities. I: Techniques for comparing the effects of fungi and insects. *Soil Biology and Biochemistry* 7:341–344.
- MacDonald, N.W., A.J. Burton, H.O. Liechty, J.A. Witter, K.S. Pregitzer, G.D. Mroz, and D.D. Richter. 1992. Atmospheric pollutants: ion leaching in forest ecosystems along a Great Lakes air pollution gradient. *Journal of Environmental Quality* 21:614–623.
- MacEvilly, C. 2000. Bugs in the system. *Nutrition Bulletin* 25:267–268.
- MacFadden, B.J., and D.S. Jones. 1985. Magnetic butterflies: a case study of the monarch (Lepidoptera, Danaidae). In *Magnetite Biomineralization and Magnetoreception in Organisms* (J.L. Kirschvink, D.S. Jones, and B.J. MacFadden, Eds.), pp. 407–415. Plenum Press, New York, NY.
- Mack, R.N., D. Simberloff, W.M. Lonsdale, H. Evans, M. Clout, and F.A. Bazzazz. 2000. Biotic invasions; causes, epidemiology, global consequences and control. *Ecological Applications* 10:689–710.
- MacKenzie, D.I., and W.L. Kendall. 2002. How should detection probability be incorporated into estimates of relative abundance? *Ecology* 83:2387–2393.
- MacMahon, J.A. 1981. Successional processes: comparisons among biomes with special reference to probable roles of and influences on animals. In *Forest Succession: Concepts and Application* (D.C. West, H.H. Shugart, and D.B. Botkin, Eds.), pp. 277–304. Springer-Verlag, New York, NY.
- MacMahon, J.A., J.F. Mull, and T.O. Crist. 2000. Harvester ants (*Pogonomyrmex* spp.): their community and ecosystem influences. *Annual Review of Ecology and Systematics* 31:265–291.
- Maddrell, S.H.P. 1962. A diuretic hormone in *Rhodnius prolixus* Stal. *Nature* 194:605–606.
- Madigosky, S.R. 2004. Tropical microclimatic considerations. In *Forest Canopies* (M.D. Lowman, and H.B. Rinker, Eds.), pp. 24–48. Elsevier/Academic Press, San Diego, CA.
- Madritch, M.D., J.R. Donaldson, and R.L. Lindroth. 2007. Canopy herbivory can mediate the influence of plant genotype on soil processes through frass deposition. *Soil Biology and Biochemistry* 39:1192–1201.
- Mafra-Neto, A., and R.T. Cardé. 1995. Influence of plume structure and pheromone concentration on upwind flight by *Cadra cautella* males. *Physiological Entomology* 20:117–133.
- Magurran, A.E. 2004. *Measuring Biological Diversity*. Blackwell Scientific, Malden, MA.
- Mahaney, W.C., J. Zippin, M.W. Milner, K. Sanmugadas, R.G.V. Hancock, S. Aufreiter, S. Campbell, M.A. Huffman, M. Wink, D. Malloch, and V. Kalm. 1999. Chemistry, mineralogy and microbiology of termite mound soil eaten by the chimpanzees of the Mahale Mountains, western Tanzania. *Journal of Tropical Ecology* 15:565–588.
- Mahon, R.J., and K.M. Olsen. 2009. Limited survival of a Cry2Ab-resistant strain of *Helicoverpa armigera* (Lepidoptera: Noctuidae) on Bollgard II. *Journal of Economic Entomology* 102:708–716.
- Mahunka S., (Ed.), 1981 and 1983. *The Fauna of the Hortobágy National Park*, Vols. 1 and 2. Akadémiai Kiadó, Budapest, Hungary.
- Mahunka S., (Ed.), 1986 and 1987. *The Fauna of the Kiskunság National Park*, Vols. 4 and 5. Akadémiai Kiadó, Budapest, Hungary.
- Mahunka S., (Ed.), 1991. *Bátorliget Nature Reserve After Forty Years*, Vols. 1 and 2. Hungarian Natural History Museum, Budapest Hungary.
- Majer, J.D., and H.F. Recher. 1988. Invertebrate communities on Western Australian eucalypts—a comparison of branch clipping and chemical knock-down procedures. *Australian Journal of Ecology* 13:269–278.

- Malausa, T., M.-T. Bethenod, A. Bontemps, D. Bourguet, J.-M. Cornuet, and S. Ponsard. 2005. Assortative mating in sympatric host races of the European corn borer. *Science* 308:258–260.
- Malcolm, S.B. 1992. Prey defense and predator foraging. In *Natural Enemies: The Population Biology of Predators, Parasites and Diseases* (M.J. Crawley, Ed.), pp. 458–475. Blackwell Scientific, London.
- Maleque, M.A., K. Maeto, and H.T. Ishii. 2009. Arthropods as bioindicators of sustainable forest management, with a focus on plantation forests. *Applied Entomology and Zoology* 44:1–11.
- Maloney, P.E., and D.M. Rizzo. 2002. Pathogens and insects in a pristine forest ecosystem: the Sierra San Pedro Martir, Baja, Mexico. *Canadian Journal of Forest Research* 32:448–457.
- Malthus, T.R. 1789. An Essay on the Principle of Population as it Affects the Future Improvement of Society. Johnson, London, UK.
- Mankowski, M.E., T.D. Schowalter, J.J. Morrell, and B. Lyons. 1998. Feeding habits and gut fauna of *Zootermopsis angusticollis* (Isoptera: Termopsidae) in response to wood species and fungal associates. *Environmental Entomology* 27:1315–1322.
- Manley, G.V. 1971. A seed-cacheing carabid (Coleoptera). *Annals of the Entomological Society of America* 64:1474–1475.
- Manville, R.H. 1942. Notes on the mammals of Mount Desert Island, Maine. *Journal of Mammalogy* 23:391–398.
- Mao, L., and G. Henderson. 2010. Group size effect on worker juvenile hormone titers and soldier differentiation in Formosan subterranean termite. *Journal of Insect Physiology* 56:725–730.
- Mao, W., S. Rupasinghe, A.R. Zangerl, M.A. Schuler, and M.R. Berenbaum. 2006. Remarkable substrate-specificity of CYP6AB3 in *Depressaria pastinacella*, a highly specialized herbivore. *Insect Molecular Biology* 15:169–179.
- Mao, Y.-B., W.-J. Cai, J.-W. Wang, G.-J. Hong, X.-Y. Tao, L.-J. Wang, Y.-P. Huang, and X.-Y. Chen. 2007. Silencing a cotton bollworm P450 monooxygenase gene by plant-mediated RNAi impairs larval tolerance for gossypol. *Nature Biotechnology* 25:1307–1313.
- Maraun, M., and S. Scheu. 1996. Changes in microbial biomass, respiration and nutrient status of beech (*Fagus sylvatica*) leaf litter processed by millipedes (*Glomeris marginata*). *Oecologia* 107:131–140.
- March, J.G., J.P. Benstead, C.M. Pringle, and M.W. Ruebel. 2001. Linking shrimp assemblages with rates of detrital processing along an elevational gradient in a tropical stream. *Canadian Journal of Fisheries and Aquatic Science* 58:470–478.
- Marcot, B.G., R.S. Holthausen, M.G. Raphael, M.M. Rowland, and M.J. Wisdom. 2001. Using Bayesian belief networks to evaluate fish and wildlife population viability under land management alternatives from an environmental impact statement. *Forest Ecology and Management* 153:29–42.
- Marino, P.C., and D.A. Landis. 1996. Effect of landscape structure on parasitoid diversity and parasitism in agroecosystems. *Ecological Applications* 6:276–284.
- Mark, S., and J.M. Olesen. 1996. Importance of elaiosome size to removal of ant-dispersed seeds. *Oecologia* 107:95–101.
- Marks, S., and D.E. Lincoln. 1996. Antiherbivore defense mutualism under elevated carbon dioxide levels: a fungal endophyte and grass. *Environmental Entomology* 25:618–623.
- Marquis, R.J. 1984. Leaf herbivores decrease fitness of a tropical plant. *Science* 226:537–539.
- Marquis, R.J., and C.J. Whelan. 1994. Insectivorous birds increase growth of white oak through consumption of leaf-chewing insects. *Ecology* 75:2007–2014.
- Marra, P.P., S. Griffing, C. Caffrey, A.M. Kilpatrick, R. McLean, C. Brand, E. Saito, A.P. Dupuis, L. Kramer, and R. Novak. 2004. West Nile virus and wildlife. *BioScience* 54:393–402.
- Marron, M.T., T.A. Markow, K.J. Kain, and A.G. Gibbs. 2003. Effects of starvation and desiccation on energy metabolism in desert and mesic *Drosophila*. *Journal of Insect Physiology* 49:261–270.
- Marschner, H. 1995. The Mineral Nutrition of Higher Plants, 2<sup>nd</sup> Ed.. Academic Press, San Diego, CA.
- Martin-R, M., J.R. Cox, F. Ibarra-F, D.G. Alston, R.E. Banner, and J.C. Malecheck. 1999. Spittlebug and buffelgrass responses to summer fires in Mexico. *Journal of Range Management* 52:621–625.
- Martínez, A.J., J. López-Portillo, A. Eben, and J. Golubov. 2009. Cerambycid girdling and water stress modify mesquite architecture and reproduction. *Population Ecology* 51:533–541.
- Martinez, N.D. 1992. Constant connectance in community food webs. *American Naturalist* 139:1208–1218.
- Martínez-Mota, R., J.C. Serio-Silva, and V. Rico-Gray. 2004. The role of canopy ants in removing *Ficus perforata* seeds from howler monkey (*Alouatta palliata mexicana*) feces at Los Tuxtlas, México. *Biotropica* 36:429–432.
- Martius, C., R. Wassmann, U. Thein, A. Bandeira, H. Rennenberg, W. Junk, and W. Seiler. 1993. Methane emission from wood-feeding termites in Amazonia. *Chemosphere* 26:623–632.
- Martius, C., P.M. Fearnside, A.G. Bandeira, and R. Wassmann. 1996. Deforestation and methane release from termites in Amazonia. *Chemosphere* 33:517–536.
- Marvier, M., C. McCreedy, J. Regetz, and P. Kareiva. 2007. A meta-analysis of effects of Bt cotton and maize on non-target invertebrates. *Science* 316:1475–1477.
- Mascari, T.M., and L.D. Foil. 2009. Evaluation of rhodamine B as an orally delivered biomarker for rodents and a feed-through transtadial biomarker

- for phlebotamine sand flies (Diptera: Psychodidae). *Journal of Medical Entomology* 46:1131–1137.
- Mascari, T.M., and L.D. Foil. 2010. Laboratory evaluation of novaluron as a rodent feed-through insecticide against sand fly larvae (Diptera: Psychodidae). *Journal of Medical Entomology* 47:205–209.
- Mascari, T.M., M.A. Mitchell, E.D. Rowton, and L.D. Foil. 2007a. Laboratory evaluation of diflubenzuron as a feed-through for control of immature sand flies (Diptera: Psychodidae). *Journal of Medical Entomology* 44:171–174.
- Mascari, T.M., M.A. Mitchell, E.D. Rowton, and L.D. Foil. 2007b. Laboratory evaluation of novaluron as a feed-through for control of immature sand flies (Diptera: Psychodidae). *Journal of Medical Entomology* 44:714–717.
- Maschinski, J., and T.G. Whitham. 1989. The continuum of plant responses to herbivory: the influence of plant association, nutrient availability, and timing. *American Naturalist* 134:1–19.
- Mason, R.R. 1996. Dynamic behavior of Douglas-fir tussock moth populations in the Pacific Northwest. *Forest Science* 42:182–191.
- Mason, R.R., and R.F. Luck. 1978. Population growth and regulation. In *The Douglas-fir Tussock Moth: a Synthesis* (M.H. Brookes, R.W. Stark, and R.W. Campbell, Eds.), pp. 41–47. USDA Forest Service Technical Bulletin. 1585. USDA Forest Service, Washington, DC.
- Massonnet, B., J.-C. Simon, and W.G. Weisser. 2002. Metapopulation structure of the specialized herbivore *Macrosiphoniella tanacetaria* (Homoptera, Aphididae). *Molecular Ecology* 11:2511–2521.
- Masters, G.J., V.K. Brown, and A.C. Gange. 1993. Plant mediated interactions between above- and below-ground insect herbivores. *Oikos* 66:148–151.
- Mathias, D., L. Jacky, W.E. Bradshaw, and C.M. Holzapfel. 2007. Quantitative trait loci associated with photoperiodic response and stage of diapause in the pitcher-plant mosquito, *Wyeomyia smithii*. *Genetics* 176:391–402.
- Matis, J.H., T.R. Kiffe, and G.W. Otis. 1994. Use of birth–death–migration processes for describing the spread of insect populations. *Environmental Entomology* 23:18–28.
- Matsuda, H., P.A. Abrams, and M. Hori. 1993. The effect of adaptive anti-predator behavior on exploitative competition and mutualism between predators. *Oikos* 68:549–559.
- Matthaei, C.D., and C.R. Townsend. 2000. Long term effects of local disturbance history on mobile stream invertebrates. *Oecologia* 125:119–126.
- Matthews, R.W., and J.R. Matthews. 2010. *Insect Behavior*, 2<sup>nd</sup> Ed.. Springer, Dordrecht, The Netherlands.
- Mattson, W.J. 1980. Herbivory in relation to plant nitrogen content. *Annual Review of Ecology and Systematics* 11:119–161.
- Mattson, W.J., and N.D. Addy. 1975. Phytophagous insects as regulators of forest primary production. *Science* 190:515–522.
- Mattson, W.J., and R.A. Haack. 1987. The role of drought in outbreaks of plant-eating insects. *BioScience* 37:110–118.
- Mauricio, R., M.D. Bowers, and F.A. Bazzaz. 1993. Pattern of leaf damage affects fitness of the annual plant *Raphanus sativus* (Brassicaceae). *Ecology* 74:2066–2071.
- May, R.M. 1973. Qualitative stability in model ecosystems. *Ecology* 54:638–641.
- May, R.M. 1981. Models for two interacting populations. In *Theoretical Ecology: Principles and Applications* (R.M. May, Ed.), pp. 78–104. Blackwell Scientific, Oxford, UK.
- May, R.M. 1983. The structure of food webs. *Nature* 301:566–568.
- May, R.M. 1988. How many species are there on Earth? *Science* 241:1441–1449.
- Mayer, B., K.H. Feger, A. Giesemann, and H.J. Jäger. 1995. Interpretation of sulfur cycling in two catchments in the Black Forest (Germany) using stable sulfur and oxygen isotope data. *Biogeochemistry* 30:31–58.
- Mazza, C.A., M.M. Izaguirre, J. Zavala, A.L. Scopel, and C.L. Balaré. 2002. Insect perception of ultraviolet-B radiation. *Ecology Letters* 5:722–726.
- Mbata, K.J., E.N. Chidumayo, and C.M. Lwatura. 2002. Traditional regulation of edible caterpillar exploitation in the Kopa area of Mpika district in northern Zambia. *Journal of Insect Conservation* 6:115–130.
- McBrayer, J.F. 1975. Exploitation of deciduous leaf litter by *Apheloria montana* (Diplopoda: Eurydesmidae). *Pedobiologia* 13:90–98.
- McCann, K.S., J.B. Rasmussen, and J. Umbanhowar. 2005. The dynamics of spatially coupled food webs. *Ecology Letters* 8:513–523.
- McCloud, E.S., and I.T. Baldwin. 1997. Herbivory and caterpillar regurgitants amplify the wound-induced increases in jasmonic acid but not nicotine in *Nicotiana sylvestris*. *Planta* 203:430–435.
- McClure, M.S. 1990. Role of wind, birds, deer, and humans in the dispersal of hemlock woolly adelgid (Homoptera: Adelgidae). *Environmental Entomology* 19:36–43.
- McClure, M.S. 1991. Density-dependent feedback and population cycles in *Adelges tsugae* (Homoptera: Adelgidae) on *Tsuga canadensis*. *Environmental Entomology* 20:258–264.
- McCoy, E.D., and J.H. Frank. 2010. How should the risk associated with the introduction of biological control agents be estimated? *Agricultural and Forest Entomology* 12:1–8.
- McCreadie, J.W., and M.H. Colbo. 1993. Larval and pupal microhabitat selection by *Simulium truncatum*, *S. rostratum* and *S. verecundum* AA (Diptera:

- Simuliidae). *Canadian Journal of Zoology* 71:358–367.
- McCullough, D.G., and M.R. Wagner. 1993. Defusing host defenses: ovipositional adaptations of sawflies to plant resins. In *Sawfly Life History Adaptations to Woody Plants* (M.R. Wagner, and K.F. Raffa, Eds.), pp. 157–172. Academic Press, San Diego, CA.
- McCullough, D.G., R.A. Werner, and D. Neumann. 1998. Fire and insects in northern and boreal forest ecosystems of North America. *Annual Review of Entomology* 43:107–127.
- McElfresh, J.S., and J.G. Millar. 2001. Geographic variation in the pheromone system of the saturniid moth *Hemileuca eglanterina*. *Ecology* 82:3505–3518.
- McElfresh, J.S., A.M. Hammond, and J.G. Millar. 2001. Sex pheromone components of the buck moth, *Hemileuca maia*. *Journal of Chemical Ecology* 27:1409–1422.
- McEvoy, P.B., C. Cox, and E. Coombs. 1991. Successful biological control of ragwort, *Senecio jacobaea*, by introduced insects in Oregon. *Ecological Applications* 1:430–442.
- McEvoy, P.B., N.T. Rudd, C.S. Cox, and M. Huso. 1993. Disturbance, competition, and herbivory effects on ragwort *Senecio jacobaea* populations. *Ecological Monographs* 63:55–75.
- McIntosh, R.P. 1981. Succession and ecological theory. In *Forest Succession: Concepts and Application* (D.C. West, H.H. Shugart, and D.B. Botkin, Eds.), pp. 10–23. Springer-Verlag, New York, NY.
- McIntyre, N.E., and J.A. Wiens. 1999. How does habitat patch size affect animal movement? An experiment with darkling beetles. *Ecology* 80:2261–2270.
- McMahan, E.A. 1982. Bait-and-capture strategy of a termite-eating assassin bug. *Insectes Sociaux* 29:346–351.
- McMahan, E.A. 1983. Adaptations, feeding preferences, and biometrics of a termite-baiting assassin bug (Hemiptera: Reduviidae). *Annals of the Entomological Society of America* 76:483–486.
- McNab, B.K. 1963. Bioenergetics and the determination of home range size. *American Naturalist* 97:133–140.
- McNaughton, S.J. 1977. Diversity and stability of ecological communities: a comment on the role of empiricism in ecology. *American Naturalist* 111:515–525.
- McNaughton, S.J. 1979. Grazing as an optimization process: grass–ungulate relationships in the Serengeti. *American Naturalist* 113:691–703.
- McNaughton, S.J. 1985. Ecology of a grazing system: the Serengeti. *Ecological Monographs* 55:259–294.
- McNaughton, S.J. 1986. On plants and herbivores. *American Naturalist* 128:765–770.
- McNaughton, S.J. 1993a. Grasses and grazers, science and management. *Ecological Applications* 3:17–20.
- McNaughton, S.J. 1993b. Biodiversity and function of grazing ecosystems. In *Biodiversity and Ecosystem Function* (E.D. Schulze, and H.A. Mooney, Eds.), pp. 361–383. Springer-Verlag, Berlin, Germany.
- McNeill, S., and J.H. Lawton. 1970. Annual production and respiration in animal populations. *Nature* 225:472–474.
- Meentemeyer, V. 1978. Macroclimate and lignin control of litter decomposition rates. *Ecology* 59:465–472.
- Mehdiabadi, N.J., and L.E. Gilbert. 2002. Colony-level impacts of parasitoid flies on fire ants. *Proceedings of the Royal Society of London B* 269:1695–1699.
- Meher-Homji, V.M. 1991. Probable impact of deforestation on hydrological processes. *Climate Change* 19:163–173.
- Mehner, T., J. Ihlau, H. Dörner, M. Hupfer, and F. Hölker. 2005. Can feeding of fish on terrestrial insects subsidize the nutrient pool of lakes? *Limnology and Oceanography* 50:2022–2031.
- Meinwald, J., and T. Eisner. 1995. The chemistry of phyletic dominance. *Proceedings of the National Academy of Sciences, USA* 92:14–18.
- Meisel, J.E. 2006. Thermal ecology of the Neotropical army ant, *Eciton burchellii*. *Ecological Applications* 16:913–922.
- Meisner, M., J.P. Harmon, and A.R. Ives. 2007. Presence of an unsuitable host diminishes the competitive superiority of an insect parasitoid: a distraction effect. *Population Ecology* 49:347–355.
- Melander, A.L. 1923. Tolerance of San Jose Scale to Sprays. State College of Washington Agricultural Experiment Station Bulletin 174, Pullman, WA.
- Meller, V.H., and R.L. Davis. 1996. Biochemistry of insect learning: lessons from bees and flies. *Insect Biochemistry and Molecular Biology* 26:327–335.
- Menéndez, R. 2007. How are insects responding to global warming? *Tijdschrift voor Entomologie* 150:355–365.
- Menninger, H.L., M.A. Palmer, L.S. Craig, and D.C. Richardson. 2008. Periodical cicada detritus impacts stream ecosystem metabolism. *Ecosystems* 11:1306–1317.
- Menzel, R., K. Geiger, J. Joerges, U. Müller, and L. Chittka. 1998. Bees travel novel homeward routes by integrating separately acquired vector memories. *Animal Behaviour* 55:139–152.
- Merlin, C., R.J. Gegear, and S.M. Reppert. 2009. Antennal circadian clocks coordinate sun compass orientation in migratory monarch butterflies. *Science* 325:1700–1704.
- Merritt, R.W., M.E. Benbow, and P.L.C. Small. 2005. Unraveling an emerging disease associated with disturbed aquatic environments: the case of Buruli ulcer. *Frontiers in Ecology and the Environment* 3:323–331.
- Mertl, A.L., K.T.R. Wilkie, and J.F.A. Traniello. 2009. Impact of flooding on the species richness, density and composition of Amazonian litter-nesting ants. *Biotropica* 41:633–641.

- Mery, F., and T.J. Kawecki. 2005. The cost of long-term memory in *Drosophila*. *Science* 308:1148.
- Meyerson, L.A., and J.K. Reaser. 2003. Bioinvasions, bioterrorism, and biosecurity. *Frontiers in Ecology and the Environment* 1:307–314.
- Michalson, E.L. 1975. Economic impact of mountain pine beetle on outdoor recreation. *Southern Journal of Agricultural Economics* 7(2):43–50.
- Michener, C.D. 1969. Comparative and social behavior of bees. *Annual Review of Entomology* 14:299–334.
- Miles, P.W. 1972. The saliva of Hemiptera. *Advances in Insect Physiology* 9:183–255.
- Millennium Ecosystem Assessment, 2005. Ecosystems and human well-being: biodiversity synthesis. World Resources Institute, Washington, DC.
- Miller, J.C., and P.E. Hanson. 1989. Laboratory Feeding Tests on the Development of Gypsy Moth Larvae with Reference to Plant Taxa and Allelochemicals. Bull. 674, Oregon Agricultural Experimental Station, Oregon State University, Corvallis, OR.
- Miller, K.K., and M.R. Wagner. 1984. Factors influencing pupal distribution of the pandora moth (Lepidoptera: Saturniidae) and their relationship to prescribed burning. *Environmental Entomology* 13:430–431.
- Miller, S.W., D. Wooster, and J. Li. 2007. Resistance and resilience of macroinvertebrates to irrigation water withdrawals. *Freshwater Biology* 52:2494–2510.
- Millspaugh, C.F. 1892. American Medicinal Plants: an Illustrated and Descriptive Guide to the American Plants Used as Homeopathic Remedies: Their History, Preparation, Chemistry and Physiological Effects. J.C. Yorston, Philadelphia, PA.
- Minchin, P.R. 1987. An evaluation of the relative robustness of techniques for ecological ordination. *Vegetatio* 69:89–107.
- Misra, R. 1968. Energy transfer along terrestrial food chain. *Tropical Ecology* 9:105–118.
- Misson, L., D.D. Baldocchi, T.A. Black, P.D. Blanken, Y. Brunet, J. Curiel Yuste, J.R. Dorsey, M. Falk, A. Granier, M.R. Irvine, N. Jarosz, E. Lamaud, S. Launiainen, B.E. Law, B. Longdoz, D. Loustau, M. McKay, K.T. Paw U, T. Vesala, D. Vickers, K.B. Wilson, and A.H. Goldstein. 2007. Partitioning forest carbon fluxes with overstory and understory eddy-covariance measurements: a synthesis based on FLUXNET data. *Agricultural and Forest Meteorology* 144:14–31.
- Mitchell, J.D., P.H. Hewitt, T.C. de, and K. van der Linde. 1993. Critical thermal limits and temperature tolerance in the harvester termite, *Hodotermes mossambicus* (Hagen). *Journal of Insect Physiology* 39:523–528.
- Mitchell, R. 1970. An analysis of dispersal in mites. *American Naturalist* 104:425–431.
- Mitchell, R. 1975. The evolution of oviposition tactics in the bean weevil, *Callosobruchus maculatus* (F.). *Ecology* 56:696–702.
- Mitchell, R.G., and R.E. Martin. 1980. Fire and insects in pine culture of the Pacific Northwest. *Proceedings of the Conference on Fire and Forest Meteorology* 6:182–190.
- Mitchell, R.G., and H. Preisler. 1992. Analysis of spatial patterns of lodgepole pine attacked by outbreak populations of mountain pine beetle. *Forest Science* 29:204–211.
- Mitchell, R.J., R.J. Flanagan, B.J. Brown, N.M. Wasser, and J.D. Karron. 2009. New frontiers in competition for pollination. *Annals of Botany* 103:1403–1413.
- Mittelbach, G.G., C.F. Steiner, S.M. Scheiner, K.L. Gross, H.L. Reynolds, R.B. Waide, M.R. Willig, S.I. Dodson, and L. Gough. 2001. What is the observed relationship between species richness and productivity? *Ecology* 82:2381–2396.
- Mittler, T.E. 1958. The excretion of honeydew by *Tuberolachnus salignus* (Gmelin) (Homoptera: Aphididae). *Proceedings of the Royal Entomological Society of London (A)* 33:49–55.
- Mittler, T.E. 1970. Uptake rates of plant sap and synthetic diet by the aphid *Myzus persicae*. *Annals of the Entomological Society of America* 63:1701–1705.
- Mittler, T.E., and E.S. Sylvester. 1961. A comparison of the injury to alfalfa by the aphids, *Therioaphis maculata* and *Microsiphum pisi*. *Journal of Economic Entomology* 54:615–622.
- Mizutani, M., and N. Hijii. 2001. Mensuration of frass drop for evaluating arthropod biomass in canopies: a comparison among *Cryptomeria japonica*, *Larix kaempferi*, and deciduous broad-leaved trees. *Forest Ecology and Management* 154:327–335.
- Mock, K.E., B.J. Bentz, E.M. O'Neill, J.P. Chong, J. Orwin, and M.E. Pfrender. 2007. Landscape-scale genetic variation in a forest outbreak species, the mountain pine beetle (*Dendroctonus ponderosae*). *Molecular Ecology* 16:553–568.
- Molano-Flores, B. 2009. Insect herbivory of ovules and seeds in native and restored prairies. *Restoration Ecology* 17:187–191.
- Moldenke, A.R. 1976. California pollination ecology and vegetation types. *Phytologia* 34:305–361.
- Moldenke, A.R. 1979. Pollination ecology as an assay for ecosystemic organization: convergent evolution in Chile and California. *Phytologia* 42:415–454.
- Moll, E.J., and B. McKenzie. 1994. Modes of dispersal of seeds in the Cape fynbos. In *Plant-animal Interactions in Mediterranean-type Ecosystems* (M. Arianoutsou, and R.H. Graves, Eds.), pp. 151–157. Kluwer, Dordrecht, The Netherlands.
- Momose, K., T. Nagamitsu, and T. Inoue. 1998a. Thrips cross-pollination of *Popowia pisocarpa* (Annonaceae) in a lowland dipterocarp forest in Sarawak. *Biotropica* 30:444–448.
- Momose, K., T. Yumoto, T. Nagamitsu, M. Kato, H. Nagamasu, S. Sakai, R.D. Harrison, T. Itioka, A.A.

- Hamid, and T. Inoue. 1998b. Pollination biology in a lowland dipterocarp forest in Sarawak, Malaysia. I. Characteristics of the plant-pollinator community in a lowland dipterocarp forest. *American Journal of Botany* 85:1477–1501.
- Mondor, E.B., M.N. Tremblay, C.S. Awmack, and R.L. Lindroth. 2004. Divergent pheromone-mediated insect behaviour under global atmospheric change. *Global Change Biology* 10:1820–1824.
- Monteith, J.L. 1973. Principles of Environmental Physics. American Elsevier, New York, NY.
- Mooney, K.A. 2006. The disruption of an ant–aphid mutualism increases the effects of birds on pine herbivores. *Ecology* 87:1805–1815.
- Mooney, K.A. 2007. Tritrophic effects of birds and ants on a canopy food web, tree growth, and phytochemistry. *Ecology* 88:2005–2014.
- Moore, A.J., W.D. Beazley, M.C. Bibby, and D.A. Devine. 1996. Antimicrobial activity of cecropins. *Journal of Antimicrobial Chemotherapy* 37:1077–1089.
- Moore, J.C., and H.W. Hunt. 1988. Resource compartmentation and the stability of real ecosystems. *Nature* 333:261–263.
- Moore, J.C., D.E. Walter, and H.W. Hunt. 1988. Arthropod regulation of micro- and mesobiota in below-ground detrital food webs. *Annual Review of Entomology* 33:419–439.
- Moore, J.R., and D.A. Maguire. 2005. Natural sway frequencies and damping ratios of trees: influence of crown structure. *Trees* 19:363–373.
- Moore, J.W. 2006. Animal ecosystem engineers in streams. *BioScience* 56:237–246.
- Moore, L.V., J.H. Myers, and R. Eng. 1988. Western tent caterpillars prefer the sunny side of the tree, but why? *Oikos* 51:321–326.
- Moore, R., and B.J. Francis. 1991. Factors influencing herbivory by insects on oak trees in pure stands and paired mixtures. *Journal of Applied Ecology* 28:305–317.
- Moore, R., S. Warrington, and J.B. Whittaker. 1991. Herbivory by insects on oak trees in pure stands compared with paired mixtures. *Journal of Applied Ecology* 28:290–304.
- Mopper, S. 1996. Adaptive genetic structure in phytophagous insect populations. *Trends in Ecology and Evolution* 11:235–238.
- Mopper, S., and S.Y. Strauss. 1998. Genetic Structure and Local Adaptation in Natural Insect Populations: Effects of Ecology, Life History, and Behavior. Chapman and Hall, New York, NY.
- Mopper, S., Y. Wang, C. Criner, and K. Hasenstein. 2004. *Iris hexagona* hormonal responses to salinity stress, leafminer herbivory, and phenology. *Ecology* 85:38–47.
- Moran, N.A., and T.G. Whitham. 1990. Differential colonization of resistant and susceptible host plants: *Pemphigus* and *Populus*. *Ecology* 71:1059–1067.
- Moran, P.A.P. 1953. The statistical analysis of the Canadian lynx cycle. II. Synchronization and meteorology. *Australian Journal of Zoology* 1:291–298.
- Moran, V.C., and T.R.E. Southwood. 1982. The guild composition of arthropod communities in trees. *Journal of Animal Ecology* 51:289–306.
- Morgan, F.D. 1968. Bionomics of siricidae. *Annual Review of Entomology* 13:239–256.
- Moretti, M., and C. Legg. 2009. Combining plant and animal traits to assess community functional responses to disturbance. *Ecography* 32:299–309.
- Morishima, I., T. Horiba, M. Iketani, E. Nishioka, and Y. Yamano. 1995. Parallel induction of cecropin and lysozyme in larvae of the silkworm *Bombyx mori*. *Developmental and Comparative Immunology* 19:357–363.
- Morón-Ríos, A., R. Dirzo, and V.J. Jaramillo. 1997a. Defoliation and below-ground herbivory in the grass *Muhlenbergia quadridentata*: effects on plant performance and on the root-feeder *Phyllophaga* sp. (Coleoptera: Melolonthidae). *Oecologia* 110:237–242.
- Morón-Ríos, A., V.J. Jaramillo, and R. Dirzo. 1997b. Species composition of root-feeding microarthropods in a subalpine grassland associated with pine forest in Mexico. *Canadian Entomologist* 129:71–80.
- Morris, R.F. 1969. Approaches to the study of population dynamics. In *Forest Insect Population Dynamics* (W.E. Waters, Ed.), pp. 9–28. USDA Forest Service Research Paper NE-125, USDA Forest Service, Northeast Forest Experimental Station, Hamden, CT.
- Morrow, P.A., and V.C. LaMarche, Jr. 1978. Tree ring evidence for chronic insect suppression of productivity in subalpine *Eucalyptus*. *Science* 201:1244–1246.
- Moser, J.C. 1963. Contents and structure of *Atta texana* nest in summer. *Annals of the Entomological Society of America* 56:286–291.
- Moser, J.C. 1985. Use of sporothecae by phoretic *Tarsonemus* mites to transport ascospores of coniferous bluestain fungi. *Transactions of the British Mycological Society* 84:750–753.
- Moser, J.C. 2006. Complete excavation and mapping of a Texas leafcutting ant nest. *Annals of the Entomological Society of America* 99:891–897.
- Moser, S.E., and J.J. Obrycki. 2009. Competition and intraguild predation among three species of coccinellids (Coleoptera: Coccinellidae). *Annals of the Entomological Society of America* 102:419–425.
- Mottern, J.L., K.M. Heinz, and P.J. Ode. 2004. Evaluating biological control of fire ants using phorid flies: effects on competitive interactions. *Biological Control* 30:566–583.
- Muff, P., C. Kropf, H. Frick, W. Nentwig, and M.H. Schmidt-Entling. 2009. Co-existence of divergent

- communities at natural boundaries: spider (Arachnida: Araneae) diversity across an alpine timberline. *Insect Conservation and Diversity* 2:36–44.
- Mumme, R.L. 2002. Scare tactics in a neotropical warbler: white tail feathers enhance flush–pursuit foraging performance in the slate-throated redstart (*Myioborus miniatus*). *The Auk* 119:1024–1035.
- Murdock, J.N., K.B. Gido, W.K. Dodds, K.N. Bertrand, and M.R. Whiles. 2010. Consumer return chronology alters recovery trajectory of stream ecosystem structure and function following drought. *Ecology* 91:1048–1062.
- Murlis, J., J.S. Elkinton, and R.T. Cardé. 1992. Odor plumes and how insects use them. *Annual Review of Entomology* 37:505–532.
- Musser, R.O., D.F. Cipollini, S.M. Hum-Musser, S.A. Williams, J.K. Brown, and G.W. Felton. 2005. Evidence that the caterpillar salivary enzyme glucose oxidase provides herbivore offense in solanaceous plants. *Archives of Insect Biochemistry and Physiology* 58:128–137.
- Musser, R.O., E. Farmer, M. Peiffer, S.A. Williams, and G.W. Felton. 2006. Ablation of caterpillar labial salivary glands: technique for determining the role of saliva in insect–plant interactions. *Journal of Chemical Ecology* 32:981–992.
- Mustajärvi, K., P. Siikamäki, S. Rytönen, and A. Lammi. 2001. Consequences of plant population size and density for plant–pollinator interactions and plant performance. *Journal of Ecology* 89:80–87.
- Mustaparta, H. 1984. Olfaction. In *Chemical Ecology of Insects* (W.J. Bell, and R.T. Cardé, Eds.), pp. 37–70. Chapman and Hall, London, UK.
- Mustaparta, H. 2002. Encoding of plant odour information in insects: peripheral and central mechanisms. *Entomologia Experimentalis et Applicata* 104:1–13.
- Myers, J.H. 1988. Can a general hypothesis explain population cycles of forest Lepidoptera? *Advances in Ecological Research* 18:179–242.
- Myers, J.H., A. Savoie, and E. van Randen. 1998. Eradication and pest management. *Annual Review of Entomology* 43:471–491.
- Myers, N. 1996. Environmental services of biodiversity. *Proceedings of the National Academy of Sciences, USA* 93:2764–2769.
- Myles, T.G. 1999. Review of secondary reproduction in termites (Insecta: Isoptera) with comments on its role in termite ecology and social evolution. *Sociobiology* 33:1–91.
- Myles, T.G. 2002. Alarm, aggregation, and defense of *Reticulitermes flavipes* in response to a naturally occurring isolate of *Metarhizium anisopliae*. *Sociobiology* 40:243–255.
- Naem, S. 1998. Species redundancy and ecosystem reliability. *Conservation Biology* 12:39–45.
- Naem, S., and S. Li. 1997. Biodiversity enhances ecosystem reliability. *Nature* 390:507–509.
- Nakadai, T., H. Koizumi, Y. Usami, M. Satoh, and T. Oikawa. 1993. Examination of the method for measuring soil respiration in cultivated land: effect of carbon dioxide concentration on soil respiration. *Ecological Research* 8:65–71.
- Nakano, S., and M. Murakami. 2001. Reciprocal subsidies: dynamic interdependence between terrestrial and aquatic food webs. *Proceedings of the National Academy of Science, U.S.A.* 98:166–170.
- Nakano, S., H. Miyasaka, and N. Kuhara. 1999. Terrestrial–aquatic linkages: riparian arthropod inputs alter trophic cascades in a stream food web. *Ecology* 80:2435–2441.
- Namba, T., Y.H. Ma, and K. Inagaki. 1988. Insect-derived crude drugs in the Chinese Song Dynasty. *Journal of Ethnopharmacology* 24:247–285.
- Nansen, C., T. Macedo, R. Swanson, and D.K. Weaver. 2009. Use of spatial structure analysis hyperspectral data cubes for detection of insect-induced stress in wheat plants. *International Journal of Remote Sensing* 30:2447–2464.
- Nansen, C., A.J. Sidumo, and S. Capareda. 2010. Variogram analysis of hyperspectral data to characterize the impact of biotic and abiotic stress of maize plants and to estimate biofuel potential. *Applied Spectroscopy* 64:627–636.
- Nardi, J.B., R.I. Mackie, and J.O. Dawson. 2002. Could microbial symbionts of arthropod guts contribute significantly to nitrogen fixation in terrestrial ecosystems? *Journal of Insect Physiology* 48:751–763.
- Nathan, R., G. Perry, J.T. Cronin, A.E. Strand, and M.L. Cain. 2003. Methods for estimating long-distance dispersal. *Oikos* 103:261–273.
- Nault, L.R., and E.D. Ammar. 1989. Leafhopper and planthopper transmission of plant viruses. *Annual Review of Entomology* 34:503–529.
- Nealis, V.G., M.K. Noseworthy, R. Turnquist, and V.R. Waring. 2009. Balancing risks of disturbance from mountain pine beetle and western spruce budworm. *Canadian Journal of Forest Research* 39:839–848.
- Nebeker, T.E., J.D. Hodges, and C.A. Blanche. 1993. Host response to bark beetle and pathogen colonization. In *Beetle-pathogen Interactions in Conifer Forests* (T.D. Schowalter, and G.M. Filip, Eds.), pp. 157–173. Academic Press, London, UK.
- Nessimian, J.L., E.M. Venticinque, J. Zuanon, P. de Marco, Jr., M. Gordo, L. Fidelis, J. D'arc Batista, and L. Juen. 2008. Land use, habitat integrity, and aquatic insect assemblages in central Amazonian streams. *Hydrobiologia* 614:117–131.
- Neville, P.J., D.J. O'Dowd, and A.L. Yen. 2008. Issues and implications for research on disturbed oceanic islands illustrated through an ant survey of the Cocos (Keeling) Islands. *Journal of Insect Conservation* 12:313–323.
- Newman, R.M. 1990. Herbivory and detritivory on freshwater macrophytes by invertebrates: a review.

- Journal of the North American Benthological Society* 10:89–114.
- Nicholls, C.I., and M.A. Altieri. 2007. Agroecology: contributions towards a renewed ecological foundation for pest management. In *Perspectives in Ecological Theory and Integrated Pest Management* (M. Kogan, and P. Jepson, Eds.), pp. 431–468. Cambridge University Press, Cambridge, UK.
- Nichols, E., T.A. Gardner, C.A. Peres, S. Spector, and the Scarabaeinae Network. 2009. Co-declining mammals and dung beetles: an impending ecological cascade. *Oikos* 118:481–487.
- Nicholson, A.J. 1933. The balance of animal populations. *Journal of Animal Ecology* 2(suppl.):131–178.
- Nicholson, A.J. 1954a. Compensatory reactions of populations to stress, and their evolutionary significance. *Australian Journal of Zoology* 2:1–8.
- Nicholson, A.J. 1954b. An outline of the dynamics of animal populations. *Australian Journal of Zoology* 2:9–65.
- Nicholson, A.J. 1958. Dynamics of insect populations. *Annual Review of Entomology* 3:107–136.
- Nicholson, A.J., and V.A. Bailey. 1935. The balance of animal populations. Part I. *Proceedings of the Zoological Society of London* 3:551–598.
- Nielsen, B.O. 1978. Above ground food resources and herbivory in a beech forest ecosystem. *Oikos* 31:273–279.
- Niemelä, J., and J.R. Spence. 1994. Distribution of forest dwelling carabids: spatial scale and concept of communities. *Ecography* 17:166–175.
- Niemelä, J., D. Langor, and J.R. Spence. 1992. Effects of clear-cut harvesting on boreal ground beetle assemblages in western Canada. *Conservation Biology* 7:551–561.
- Niesenbaum, R.A. 1992. The effects of light environment on herbivory and growth in the dioecious shrub *Lindera benzoin* (Lauraceae). *American Midland Naturalist* 128:270–275.
- Niwa, C.G., G.E. Daterman, C. Sartwell, and L.L. Sower. 1988. Control of *Rhyacionia zozana* (Lepidoptera: Tortricidae) by mating disruption with synthetic sex pheromone. *Environmental Entomology* 17:593–595.
- Norman, E.M., and D. Clayton. 1986. Reproductive biology of two Florida pawpaws: *Asimina obovata* and *A. pygmaea* (Annonaceae). *Bulletin of the Torrey Botanical Club* 113:16–22.
- Norman, E.M., K. Rice, and S. Cochran. 1992. Reproductive biology of *Asimina parviflora* (Annonaceae). *Bulletin of the Torrey Botanical Club* 119:1–5.
- North, M., J. Innes, and H. Zald. 2007. Comparison of thinning and prescribed fire restoration treatments to Sierran mixed-conifer historic conditions. *Canadian Journal of Forest Research* 37:331–342.
- Norton, R.A., and V.M. Behan-Pelletier. 1991. Calcium carbonate and calcium oxalate as cuticular hardening agents in oribatid mites (Acari: Oribatida). *Canadian Journal of Zoology* 69:1504–1511.
- Nothnagle, P.J., and J.C. Schultz. 1987. What is a forest pest? In *Insect Outbreaks* (P. Barbosa, and J.C. Schultz, Eds.), pp. 59–80. Academic Press, San Diego, CA.
- Novotný, V., and Y. Basset. 2000. Rare species in communities of tropical insect herbivores: pondering the mystery of singletons. *Oikos* 89:564–572.
- Novotný, V., Y. Basset, S.E. Miller, G.D. Weiblen, B. Bremer, L. Cizek, and P. Drozd. 2002. Low host specificity of herbivorous insects in a tropical forest. *Nature* 416:841–844.
- Novotný, V., P. Drozd, S.E. Miller, M. Kulfan, M. Janda, Y. Basset, and G.D. Weiblen. 2006. Why are there so many species of herbivorous insects in tropical rainforests? *Science* 313:1115–1118.
- Nowlin, W.H., M.J. González, M.J. Vanni, M.H.H. Stevens, M.W. Fields, and J.J. Valenti. 2007. Allochthonous subsidy of periodical cicadas affects the dynamics and stability of pond communities. *Ecology* 88:2174–2186.
- Oberrath, R., and K. Böhning-Gaese. 2002. Phenological adaptation of ant-dispersed plants to seasonal variation in ant activity. *Ecology* 83:1412–1420.
- O'Callaghan, M., T.R. Glare, E.P.J. Burgess, and L.A. Malone. 2005. Effects of plants genetically modified for insect resistance on nontarget organisms. *Annual Review of Entomology* 50:271–292.
- O'Connell, A.M., and P. Menagé. 1983. Decomposition of litter from three major plant species of jarrah (*Eucalyptus marginata* Donn ex Sm.) forest in relation to site fire history and soil type. *Australian Journal of Ecology* 8:277–286.
- O'Dowd, D.J., and M.E. Hay. 1980. Mutualism between harvester ants and a desert ephemeral: seed escape from rodents. *Ecology* 61:531–540.
- O'Dowd, D.J., and M.F. Willson. 1991. Associations between mites and leaf domatia. *Trends in Ecology and Evolution* 6:179–182.
- Odum, E.P. 1953. *Fundamentals of Ecology*. W.B. Saunders, Philadelphia, PA.
- Odum, E.P. 1969. The strategy of ecosystem development. *Science* 164:262–270.
- Odum, E.P. 1971. *Fundamentals of Ecology*, 3<sup>rd</sup> Ed. W.B. Saunders, Philadelphia, PA.
- Odum, E.P., and A.E. Smalley. 1959. Comparison of population energy flow of a herbivorous and a deposit-feeding invertebrate in a salt marsh ecosystem. *Proceedings of the National Academy of Sciences, USA* 45:617–622.
- Odum, H.T. 1957. Trophic structure and productivity of Silver Springs, Florida. *Ecological Monographs* 27:55–112.
- Odum, H.T. 1996. *Environmental Accounting: Emergency and Environmental Decision Making*. John Wiley, New York, NY.
- Odum, H.T., and R.C. Pinkerton. 1955. Time's speed regulator: the optimum efficiency for maximum power output in physical and biological systems. *American Scientist* 43:331–343.



- Odum, H.T., and J. Ruíz-Reyes. 1970. Holes in leaves and the grazing control mechanism. In *A Tropical Rain Forest* (H.T. Odum, and R.F. Pigeon, Eds.), pp. I-69–I-80. U.S. Atomic Energy Commission, Oak Ridge, TN.
- Oertli, B. 1993. Leaf litter processing and energy flow through macroinvertebrates in a woodland pond (Switzerland). *Oecologia* 96:466–477.
- Oesterheld, M., and S.J. McNaughton. 1988. Intraspecific variation in the response of *Themeda triandra* to defoliation: the effect of time of recovery and growth rates on compensatory growth. *Oecologia* 77:181–186.
- Oesterheld, M., and S.J. McNaughton. 1991. Effect of stress and time for recovery on the amount of compensatory growth after grazing. *Oecologia* 85:305–313.
- Oesterheld, M., O.E. Sala, and S.J. McNaughton. 1992. Effect of animal husbandry on herbivore-carrying capacity at a regional scale. *Nature* 356:234–236.
- Ohashi, K., and J.D. Thomson. 2009. Trapline foraging by pollinators: its ontogeny, economics and possible consequences for plants. *Annals of Botany* 103:1365–1378.
- Ohashi, K., J.D. Thomson, and D. D'Souza. 2007. Trapline foraging by bumble bees. IV. Optimization of route geometry in the absence of competition. *Behavioral Ecology* 18:1–11.
- Ohashi, K., A. Leslie, and J.D. Thomson. 2008. Trapline foraging by bumble bees. V. Effects of experience and priority on competitive performance. *Behavioral Ecology* 19:936–948.
- Ohgushi, T. 1995. Adaptive behavior produces stability of herbivorous lady beetle populations. In *Population Dynamics: New Approaches and Synthesis* (N. Cappuccino, and P.W. Price, Eds.), pp. 303–319. Academic Press, San Diego, CA.
- Ohgushi, T. 2005. Indirect interaction webs: herbivore-induced effects through trait change in plants. *Annual Review of Ecology, Evolution and Systematics* 36:81–105.
- Ohgushi, T. 2008. Herbivore-induced indirect interaction webs on terrestrial plants: the importance of nontrophic, indirect, and facultative interactions. *Entomologia Experimentalis et Applicata* 128:217–229.
- Ohgushi, T., and H. Sawada. 1985. Population equilibrium with respect to available food resource and its behavioural basis in an herbivorous lady beetle *Henosepilachna niponica*. *Journal of Animal Ecology* 54:781–796.
- Ohkawara, K., S. Higashi, and M. Ohara. 1996. Effects of ants, ground beetles and the seed-fall patterns on myrmecochory of *Erythronium japonicum* Decne. (Liliaceae). *Oecologia* 106:500–506.
- Ohmart, C.P., L.G. Stewart, and J.R. Thomas. 1983. Phytophagous insect communities in the canopies of three *Eucalyptus* forest types in south-eastern Australia. *Australian Journal of Ecology* 8:395–403.
- Ohmart, C.P., L.G. Stewart, and J.R. Thomas. 1985. Effects of nitrogen concentrations of *Eucalyptus blakei* foliage on the fecundity of *Paropsis atomaria* (Coleoptera: Chrysomelidae). *Oecologia* 68:41–44.
- Økland, B., A.M. Liebhold, A. Bjørnstad, N. Erbilgin, and P. Krokene. 2005. Are bark beetle outbreaks less synchronous than forest Lepidoptera outbreaks? *Oecologia* 146:365–372.
- Økland, B., O. Skarpaas, and K. Kausrud. 2009. Threshold facilitations of interacting species. *Population Ecology* 51:513–523.
- Oksanen, L. 1983. Trophic exploitation and arctic phytomass patterns. *American Naturalist* 122:45–52.
- Oliveira, P.S., and C.R.F. Brandão. 1991. The ant community associated with extrafloral nectaries in the Brazilian cerrados. In *Ant-plant Interactions* (C.R. Huxley, and D.F. Cutler, Eds.), pp. 198–212. Oxford University Press, Oxford, UK.
- Oliveira, P.S., M. Galetti, F. Pedroni, and L.P.C. Morellato. 1995. Seed cleaning by *Mycocarpus goeldii* ants (Attini) facilitates germination in *Hymenaea courbaril* (Caesalpinaceae). *Biotropica* 27:518–522.
- Olson, J.S. 1963. Energy storage and the balance of producers and decomposers in ecological systems. *Ecology* 44:322–331.
- O'Neill, R.V. 2001. Is it time to bury the ecosystem concept? (with full military honors, of course!). *Ecology* 82:3275–3284.
- O'Neill, R.V., D.L. DeAngelis, J.B. Waide, and T.F.H. Allen. 1986. A Hierarchical Concept of Ecosystems. Princeton University Press, Princeton, NJ.
- Onstad, D.W., D.W. Crowder, S.A. Isard, E. Levine, J.L. Spencer, M.E. O'Neal, S.T. Ratcliffe, M.E. Gray, L.W. Bledsoe, C.D. Di Fonzo, J.B. Eislely, and C.R. Edwards. 2003. Does landscape diversity slow the spread of rotation-resistant western corn rootworm (Coleoptera: Chrysomelidae)? *Environmental Entomology* 32:992–1001.
- Orr, M.R., D.L. Dahlsten, and W.W. Benson. 2003. Ecological interactions among ants in the genus *Linepithema*, their phorid parasitoids, and ant competitors. *Ecological Entomology* 28:203–210.
- Orwig, D.A. 2002. Ecosystem to regional impacts of introduced pests and pathogens: historical context, questions and issues. *Journal of Biogeography* 29:1471–1474.
- Orwig, D.A., D.R. Foster, and D.L. Mauseel. 2002. Landscape patterns of hemlock decline in New England due to the introduced hemlock woolly adelgid. *Journal of Biogeography* 29:1475–1487.
- Ostfeld, R.S., and F. Keesing. 2000. Biodiversity and disease risk: the case of Lyme disease. *Conservation Biology* 14:722–728.
- Ostfeld, R.S., R.H. Manson, and C.D. Canham. 1997. Effects of rodents on survival of tree seeds and seedlings invading old fields. *Ecology* 78:1531–1542.
- Ostrom, P.H., M. Colunga-Garcia, and S.H. Gage. 1997. Establishing pathways of energy flow for in-

- sect predators using stable isotope ratios: field and laboratory evidence. *Oecologia* 109:108–113.
- Otte, D., and A. Joern. 1975. Insect territoriality and its evolution: population studies of desert grasshoppers on creosote bushes. *Journal of Animal Ecology* 44:29–54.
- Ottea, J., and R. Leonard. 2006. Insecticide/acaricide resistance and management strategies. In *Use and Management of Insecticides, Acaricides, and Transgenic Crops* (J.N. All, and M.F. Treacy, Eds.), pp. 82–92. Entomological Society of America, Lanham, MD.
- Owen, D.F. 1978. Why do aphids synthesize melezitose? *Oikos* 31:264–267.
- Owen, D.F., and R.G. Wiegert. 1976. Do consumers maximize plant fitness? *Oikos* 27:488–492.
- Ozaki, M., A. Wada-Katsumata, K. Fujikawa, M. Iwasaki, F. Yokohari, Y. Satoji, T. Nisimura, and R. Yamaoka. 2005. Ant nestmate and non-nestmate discrimination by a chemosensory sensillum. *Science* 309:311–314.
- Paige, K.N., and T.G. Whitham. 1987. Overcompensation in response to mammalian herbivory: the advantage of being eaten. *American Naturalist* 129:407–416.
- Paine, R.T. 1966. Food web complexity and species diversity. *American Naturalist* 100:65–75.
- Paine, R.T. 1969a. The *Pisaster–Tegula* interaction: prey patches, predator food preference, and intertidal community structure. *Ecology* 50:950–961.
- Paine, R.T. 1969b. A note on trophic complexity and community stability. *American Naturalist* 103:91–93.
- Paine, T.D., and F.A. Baker. 1993. Abiotic and biotic predisposition. In *Beetle–pathogen Interactions in Conifer Forests* (T.D. Schowalter, and G.M. Filip, Eds.), pp. 61–79. Academic Press, London, UK.
- Painter, E.L., and A.J. Belsky. 1993. Application of herbivore optimization theory to rangelands of the western United States. *Ecological Applications* 3:2–9.
- Painter, R.H. 1936. The food of insects and its relation to resistance of plants to insect attack. *American Naturalist* 70:547–566.
- Painter, R.H. 1951. Insect resistance in crop plants. The Macmillan Co., New York, NY.
- Palmer, T.M. 2003. Spatial habitat heterogeneity influences competition and coexistence in an African acacia ant guild. *Ecology* 84:2843–2855.
- Palmisano, S., and L.R. Fox. 1997. Effects of mammal and insect herbivory on population dynamics of a native Californian thistle, *Cirsium occidentale*. *Oecologia* 111:413–421.
- Pamilo, P., P. Gertsch, P. Thorén, and P. Seppä. 1997. Molecular population genetics of social insects. *Annual Review of Ecology and Systematics* 28:1–25.
- Paoletti, M.G., R.A.J. Taylor, B.R. Stinner, D.H. Stinner, and D.H. Benzing. 1991. Diversity of soil fauna in the canopy and forest floor of a Venezuelan cloud forest. *Journal of Tropical Ecology* 7:373–383.
- Papaj, D.R., and R.J. Prokopy. 1989. Ecological and evolutionary aspects of learning in phytophagous insects. *Annual Review of Entomology* 34:315–350.
- Papaj, D.R., H.S. Mallory, and C.A. Heinz. 2007. Extreme weather change and the dynamics of oviposition behavior in the pipevine swallowtail, *Battus philenor*. *Oecologia* 152:365–375.
- Paquin, P., and D. Coderre. 1997. Deforestation and fire impact on edaphic insect larvae and other macroarthropods. *Environmental Entomology* 26:21–30.
- Paradise, C.J. 2004. Relationship of water and leaf litter variability to insects inhabiting treeholes. *Journal of the North American Benthological Society* 23:793–805.
- Park, T. 1948. Experimental studies of interspecies competition. I. Competition between populations of the flour beetles, *Tribolium confusum* Duval and *Tribolium castaneum* Herbst. *Ecological Monographs* 18:265–308.
- Park, T. 1954. Experimental studies of interspecies competition. II. Temperature, humidity and competition in two species of *Tribolium*. *Physiological Zoology* 27:177–238.
- Parker, G.G. 1983. Throughfall and stemflow in the forest nutrient cycle. *Advances in Ecological Research* 13:57–133.
- Parker, G.G. 1995. Structure and microclimate of forest canopies. In *Forest Canopies* (M.D. Lowman, and N.M. Nadkarni, Eds.), pp. 73–106. Academic Press, San Diego, CA.
- Parker, J. 2003. World honey prices bolstered by smaller 2002 production, U.S. antidumping tariffs and fears about contaminated Chinese honey. *American Bee Journal* 143:523–525.
- Parker, L.W., H.G. Fowler, G. Ettershank, and W.G. Whitford. 1982. The effects of subterranean termite removal on desert soil nitrogen and ephemeral flora. *Journal of Arid Environments* 5:53–59.
- Parker, M.A. 1985. Size dependent herbivore attack and the demography of an arid grassland shrub. *Ecology* 66:850–860.
- Parkinson, K.J. 1981. An improved method for measuring soil respiration in the field. *Journal of Applied Ecology* 18:221–228.
- Parmenter, R.R., E.P. Yadav, C.A. Parmenter, P. Ettestad, and K.L. Gage. 1999. Incidence of plague associated with increased winter–spring precipitation in New Mexico. *American Journal of Tropical Medicine and Hygiene* 61:814–821.
- Parmesan, C., and G. Yohe. 2003. A globally coherent fingerprint of climate change impacts across natural systems. *Nature* 421:37–42.
- Parry, D., and R.A. Goyer. 2004. Variation in the suitability of host tree species for geographically discrete populations of forest tent caterpillar. *Environmental Entomology* 33:1477–1487.

- Parry, D., J.R. Spence, and W.J.A. Volney. 1997. Responses of natural enemies to experimentally increased populations of the forest tent caterpillar, *Malacosoma disstria*. *Ecological Entomology* 22:97–108.
- Parsons, G.L., G. Cassis, A.R. Moldenke, J.D. Lattn, N.H. Anderson, J.C. Miller, P. Hammond, and T.D. Schowalter. 1991. Invertebrates of the H.J. Andrews Experimental Forest, Western Cascade Range, Oregon. V: an Annotated List of Insects and Other Arthropods. Gen. Tech. Rpt. PNW-GTR-290. USDA Forest Service, Pacific Northwest Research Station, Portland, OR.
- Parsons, K.A., and A.A. de la Cruz. 1980. Energy flow and grazing behavior of conocephaline grasshoppers in a *Juncus roemerianus* marsh. *Ecology* 61:1045–1050.
- Parsons, T.J., H.D. Bradshaw, Jr., and M.P. Gordon. 1989. Systematic accumulation of specific mRNAs in response to wounding in poplar trees. *Proceedings of the National Academy of Science, USA* 86:7895–7899.
- Parton, W.J., J.M.O. Scurlock, D.S. Ojima, T.G. Gilmanov, R.J. Scholes, D.S. Schimel, T. Kirchner, J.-C. Menaut, T. Seastedt, E.G. Moya, A. Kamnalrut, and J.I. Kinyamario. 1993. Observations and modeling of biomass and soil organic matter dynamics for the grassland biome worldwide. *Global Biogeochemical Cycles* 7:785–809.
- Paschold, A., R. Halitschke, and I.T. Baldwin. 2007. Co(i)-ordinating defenses: NaCOII mediates herbivore-induced resistance in *Nicotiana attenuata* and reveals the role of herbivore movement in avoiding defenses. *Plant Journal* 51:79–91.
- Passos, L., and P.S. Oliveira. 2003. Interactions between ants, fruits and seeds in a restinga forest in south-eastern Brazil. *Journal of Tropical Ecology* 19:261–270.
- Patnaik, S., and P.S. Ramakrishnan. 1989. Comparative study of energy flow through village ecosystems of two co-existing communities (the Khasis and the Nepalis) of Meghalaya in north-east India. *Agricultural Systems* 30:245–267.
- Patten, B.C. 1995. Network integration of ecological extremal principles: exergy, emergy, power, ascendancy, and indirect effects. *Ecological Modelling* 79:75–84.
- Patten, B.C., and E.P. Odum. 1981. The cybernetic nature of ecosystems. *American Naturalist* 118:886–895.
- Patten, D.T. 1993. Herbivore optimization and overcompensation: does native herbivory on western rangelands support these theories? *Ecological Applications* 3:35–36.
- Payne, J.A. 1965. A summer carrion study of the baby pig *Sus scrofa* Linnaeus. *Ecology* 46:592–602.
- Peakall, R., and A.J. Beattie. 1996. Ecological and genetic consequences of pollination by sexual deception in the orchid *Caladenia tentaculata*. *Evolution* 50:2207–2220.
- Peakall, R., A.J. Beattie, and S.H. James. 1987. Pseudocopulation of an orchid by male ants: a test of two hypotheses accounting for the rarity of ant pollination. *Oecologia* 73:522–524.
- Pearl, R. 1928. *The Rate of Living*. Knopf, New York, NY.
- Pearl, R., and L.J. Reed. 1920. On the rate of growth of the population of the United States since 1790 and its mathematical representation. *Proceedings of the National Academy of Sciences, USA* 6:275–288.
- Pearson, T.R.H., D.F.R.P. Burslem, R.E. Goeriz, and J.W. Dalling. 2003. Regeneration niche partitioning in neotropical pioneers: effects of gap size, seasonal drought and herbivory on growth and survival. *Oecologia* 137:456–465.
- Péché, G. 1993. Fire hazard in budworm-killed balsam fir stands on Cape Breton Highlands. *Forestry Chronicle* 69:178–186.
- Pedigo, L.P., S.H. Hutchins, and L.G. Higley. 1986. Economic injury levels in theory and practice. *Annual Review of Entomology* 31:341–368.
- Peet, R.K., and N.L. Christensen. 1980. Succession; a population process. *Vegetatio* 43:131–140.
- Pemberton, R.W. 1999. Insects and other arthropods used as drugs by Korean traditional medicine. *Journal of Ethnopharmacology* 65:207–216.
- Pérez-Lachaud, G., T.P. Batchelor, and I.C.W. Hardy. 2004. Wasp eat wasp: facultative hyperparasitism and intra-guild predation by bethylid wasps. *Biological Control* 30:149–155.
- Perlman, F., E. Press, J.A. Googins, A. Malley, and H. Poarea. 1976. Tussockosis: reactions to Douglas-fir tussock moth. *Annals of Allergy* 36:302–307.
- Perry, D.R. 1984. The canopy of the tropical rain forest. *Scientific American* 251(5):138–147.
- Petanidou, T., and D. Vokou. 1990. Pollination and pollen energetics in Mediterranean ecosystems. *American Journal of Botany* 77:986–992.
- Petelle, M. 1980. Aphids and melezitose: a test of Owen's 1978 hypothesis. *Oikos* 35:127–128.
- Peterson, J.R., and D.J. Merrell. 1983. Rare male mating disadvantage in *Drosophila melanogaster*. *Evolution* 37:1306–1316.
- Peterson, L.R., V. Trivett, A.J.M. Baker, C. Agular, and A.J. Pollard. 2003. Spread of metals through invertebrate food chain as influenced by a plant that hyperaccumulates nickel. *Chemoecology* 13:103–108.
- Peterson, R.K.D. 1995. Insects, disease, and military history. *American Entomologist* 41:147–160.
- Peterson, R.K.D. 2009. The real enemy: scrub typhus and the invasion of Sansapor. *American Entomologist* 55:91–94.
- Petrusewicz, K. (Ed.) 1967. *Secondary Productivity of Terrestrial Ecosystems: Principles and Methods*. Pan'stwowe Wydawnictwo Naukowe, Warszawa, Poland.

- Phillipson, J. 1981. Bioenergetic options and phylogeny. In *Physiological Ecology: an Evolutionary Approach to Resource Use* (C.R. Townsend, and P. Calow, Eds.), pp. 20–45. Blackwell Scientific, Oxford, UK.
- Pianka, E.R. 1974. *Evolutionary Ecology*. Harper & Row, New York, NY.
- Pianka, E.R. 1981. Competition and niche theory. In *Theoretical Ecology: Principles and Applications* (R.M. May, Ed.), pp. 167–196. Blackwell Scientific, Oxford, UK.
- Pickett, S.T.A., and P.S. White. 1985. Patch dynamics: a synthesis. In *The Ecology of Natural Disturbance and Patch Dynamics* (S.T.A. Pickett, and P.S. White, Eds.), pp. 371–384. Academic Press, Orlando, FL.
- Pielke, R.A., and P.L. Vidale. 1995. The boreal forest and the polar front. *Journal of Geophysical Research* 100:25755–25758.
- Pimentel, D., L. Lach, R. Zuniga, and D. Morrison. 2000. Environmental and economic costs of nonindigenous species in the United States. *BioScience* 50:53–65.
- Pimm, S.L. 1980. Properties of food webs. *Ecology* 61:219–225.
- Pimm, S.L. 1982. *Food Webs*. Chapman and Hall, London, UK.
- Pimm, S.L., and R.L. Kitching. 1987. The determinants of food chain length. *Oikos* 50:302–307.
- Pimm, S.L., and J.H. Lawton. 1977. Number of trophic levels in ecological communities. *Nature* 268:329–331.
- Pimm, S.L., and J.H. Lawton. 1980. Are food webs divided into compartments? *Journal of Animal Ecology* 49:879–898.
- Pimm, S.L., and J.C. Rice. 1987. The dynamics of multispecies, multi-life-stage models of aquatic food webs. *Theoretical Population Biology* 32:303–325.
- Pimm, S.L., J.H. Lawton, and J.E. Cohen. 1991. Food web patterns and their consequences. *Nature* 350:669–674.
- Pinder, L.C.V., and D.J. Morley. 1995. Chironomidae as indicators of water quality—with a comparison of the chironomid faunas of a series of contrasting Cumbrian tarns. In *Insects in a Changing Environment* (R. Harrington, and N.E. Stork, Eds.), pp. 271–293. Academic Press, London, UK.
- Plapp, F.W. 1976. Biochemical genetics of insecticide resistance. *Annual Review of Entomology* 21:179–197.
- Platt, W.J., and J.H. Connell. 2003. Natural disturbances and directional replacement of species. *Ecological Monographs* 73:507–522.
- Pohlman, C.L., S.M. Turton, and M. Goosem. 2007. Edge effects of linear canopy openings on tropical rain forest understory microclimate. *Biotropica* 39:62–71.
- Poinar, G.O. Jr., 1993. Insects in amber. *Annual Review of Entomology* 38:145–159.
- Poinar, G.O. Jr., 2001. Dominican Amber. In *Palaeobiology II* (D.E. Briggs, and P.R. Crowther, Eds.), Blackwell, Malden, MA.
- Poinar, G. Jr., 2002. First fossil record of nematode parasitism of ants: a 40 million year tale. *Parasitology* 125:457–459.
- Poinar, G. Jr., 2005. *Plasmodium dominicana* n. sp. (Plasmodiidae: Haemospororida) from Tertiary Dominican amber. *Systematic Parasitology* 61:47–52.
- Poinar, G. Jr., 2009. Early Cretaceous protest flagellates (Parabasilia: Hypermastigia: Oxymonada) of cockroaches (Insecta: Blattaria) in Burmese amber. *Cretaceous Research* 30:1066–1072.
- Poinar, G., Jr., and R. Poinar. 1994. *The Quest for Life in Amber*. Addison–Wesley, New York, NY.
- Poinar, G., Jr., and R. Poinar. 1999. *The Amber Forest: A Reconstruction of a Vanished World*. Princeton University Press, Princeton, NJ.
- Poinar, G., Jr., and R. Poinar. 2004a. *Palaeoleishmania proterus* n. gen., n. sp., (Trypanosomatida: Kinetoplastida) from Cretaceous Burmese amber. *Protist* 155:305–310.
- Poinar, G., Jr., and R. Poinar. 2004b. Evidence of vector-borne disease of early Cretaceous reptiles. *Vector-borne and Zoonotic Diseases* 4:281–284.
- Poinar, G., Jr., and R. Poinar. 2005. Fossil evidence of insect pathogens. *Journal of Invertebrate Pathology* 89:243–250.
- Poinar, G., Jr., and R. Poinar. 2007. *What Bugged the Dinosaurs? Insects, Disease, and Death in the Cretaceous*. Princeton University Press, Princeton, NJ.
- Poinar, G., Jr., and S.R. Telford, Jr.. 2005. *Paleohaemoproteus burmacis* gen. n., sp. n. (Haemospororida: Plasmodiidae) from an early Cretaceous biting midge (Diptera: Ceratopogonidae). *Parasitology* 131:79–84.
- Poinar, G.O., Jr., C.J. Marshall, and R. Buckley. 2007. One hundred million years of chemical warfare by insects. *Journal of Chemical Ecology* 33:1663–1669.
- Poland, T.M., J.H. Borden, A.J. Stock, and L.J. Chong. 1998. Green leaf volatiles disrupt responses by the spruce beetle, *Dendroctonus rufipennis*, and the western pine beetle, *Dendroctonus brevicomis* (Coleoptera: Scolytidae) to attractant-baited traps. *Journal of the Entomological Society of British Columbia* 95:17–24.
- Polis, G.A. 1991a. Desert communities: an overview of patterns and processes. In *The Ecology of Desert Communities* (G.A. Polis, Ed.), pp. 1–26. University of Arizona Press, Tucson, AZ.
- Polis, G.A. 1991b. Food webs in desert communities: complexity via diversity and omnivory. In *The Ecology of Desert Communities* (G.A. Polis, Ed.), pp. 383–429. University of Arizona Press, Tucson, AZ.
- Polis, G.A., and D.R. Strong. 1996. Food web complexity and community dynamics. *American Naturalist* 147:813–846.

- Polis, G.A., C. Myers, and M. Quinlan. 1986. Burrowing biology and spatial distribution of desert scorpions. *Journal of Arid Environments* 10:137–145.
- Polis, G.A., W.B. Anderson, and R.D. Holt. 1997a. Toward an integration of landscape and food web ecology: the dynamics of spatially subsidized food webs. *Annual Review of Ecology and Systematics* 28:289–316.
- Polis, G.A., S.D. Hurd, C.T. Jackson, and F. Sanchez-Piñero. 1997b. El Niño effects on the dynamics and control of an island ecosystem in the Gulf of California. *Ecology* 78:1884–1897.
- Polis, G.A., S.D. Hurd, C.T. Jackson, and F. Sanchez-Piñero. 1998. Multifactor population limitation: variable spatial and temporal control of spiders on Gulf of California islands. *Ecology* 79:490–502.
- Pollard, A.J., and A.J.M. Baker. 1997. Deterrence of herbivory by zinc hyperaccumulation in *Thlaspi caerulescens* (Brassicaceae). *New Phytologist* 135:655–658.
- Ponsard, S., and R. Arditì. 2000. What can stable isotopes ( $d^{15}N$  and  $d^{13}C$ ) tell us about the food web of soil macro-invertebrates? *Ecology* 81:852–864.
- Ponyi, J.E., I. Tátrai, and A. Frankó. 1983. Quantitative studies on Chironomidae and Oligochaeta in the benthos of Lake Balaton. *Archiv für Hydrobiologie* 97:196–207.
- Pope, D.N., R.N. Coulson, W.S. Fargo, J.A. Gagne, and C.W. Kelly. 1980. The allocation process and between-tree survival probabilities in *Dendroctonus frontalis* infestations. *Researches in Population Ecology* 22:197–210.
- Porder, S., G.P. Asner, and P.M. Vitousek. 2005. Ground-based and remotely sensed nutrient availability across a tropical landscape. *Proceedings of the National Academy of Sciences, USA* 102:10909–10912.
- Porter, E.E., and R.A. Redak. 1996. Short-term recovery of grasshopper communities (Orthoptera: Acrididae) of a California native grassland after prescribed burning. *Environmental Entomology* 25:987–992.
- Porter, S.D., and D.A. Savignano. 1990. Invasion of polygynous fire ants decimates native ants and disrupts arthropod community. *Ecology* 71:2095–2106.
- Post, D.A., and J.A. Jones. 2001. Hydrologic regimes of forested, mountainous, headwater basins in New Hampshire, North Carolina, Oregon, and Puerto Rico. *Advances in Water Resources* 24:1195–1210.
- Poveda, K., I. Steffan-Dewenter, S. Scheu, and T. Tscharntke. 2007. Plant-mediated interactions between below- and aboveground processes: decomposition, herbivory, parasitism, and pollination. In *Ecological Communities: Plant Mediation in Indirect Interaction Webs* (T. Ohgushi, T.P. Craig, and P.W. Price, Eds.), pp. 147–163. Cambridge University Press, Cambridge, UK.
- Póvoa, M.M., J.E. Conn, C.D. Schlichting, J.C.O.F. Amaral, M.N.O. Segura, A.N.M. da Silva, C.C.B. dos Santos, R.N.L. Lacerda, R.T.L. de Souza, D. Galiza, E.P.S. Rosa, and R.A. Wirtz. 2003. Malaria vectors, epidemiology, and the re-emergence of *Anopheles darlingi* in Belém, Pará, Brazil. *Journal of Medical Entomology* 40:379–386.
- Powell, A.H., and G.V.N. Powell. 1987. Population dynamics of male euglossine bees in Amazonian forest fragments. *Biotropica* 19:176–179.
- Power, M.E. 1992. Top-down and bottom-up forces in food webs: do plants have primacy? *Ecology* 73:733–746.
- Power, M.E., D. Tilman, J.A. Estes, B.A. Menge, W.J. Bond, L.S. Mills, G. Daily, J.C. Castilla, J. Lubchenco, and R.T. Paine. 1996. Challenges in the quest for keystones. *BioScience* 46:609–620.
- Prange, H.D., and B. Pinshow. 1994. Thermoregulation of an unusual grasshopper in a desert environment: the importance of food source and body size. *Journal of Thermal Biology* 19:75–78.
- Pray, C.L., W.H. Nowlin, and M.J. Vanni. 2009. Deposition and decomposition of periodical cicadas (Homoptera: Cicadidae: Magicicada) in woodland aquatic ecosystems. *Journal of the North American Benthological Society* 28:181–195.
- Presley, S.J., C.L. Higgins, and M.R. Willig. 2010. A comprehensive framework for the evaluation of metacommunity structure. *Oikos* 119:908–917.
- Pretty, J.N., J.I.L. Morison, and R.E. Hine. 2003. Reducing food poverty by increasing agricultural sustainability in developing countries. *Agriculture, Ecosystems and Environment* 95:217–234.
- Price, P.W. 1980. *Evolutionary Biology of Parasites. Monographs in Population Biology* 15. Princeton University Press, Princeton, NJ.
- Price, P.W. 1986. Ecological aspects of host plant resistance and biological control: interactions among three trophic levels. In *Interactions of Plant Resistance and Parasitoids and Predators of Insects* (D.J. Boethel, and R.D. Eikenbary, Eds.), pp. 11–30. Ellis Horwood Ltd, Chichester, UK.
- Price, P.W. 1991. The plant vigor hypothesis and herbivore attack. *Oikos* 62:244–251.
- Price, P.W. 1997. *Insect Ecology*, 3<sup>rd</sup> Ed. John Wiley & Sons, New York, NY.
- Price, P.W., C.E. Bouton, P. Gross, B.A. McPherson, J.N. Thompson, and A.E. Weis. 1980. Interactions among three trophic levels: influence of plants on interactions between insect herbivores and natural enemies. *Annual Review of Ecology and Systematics* 11:41–65.
- Price, P.W., G.W. Fernandes, and G.W. Waring. 1987. Adaptive nature of insect galls. *Environmental Entomology* 16:15–24.
- Priesser, E.L., and D.R. Strong. 2004. Climate affects predator control of an herbivore outbreak. *American Naturalist* 163:754–762.
- Pringle, C.M. 1997. Exploring how disturbance is transmitted upstream: going against the flow. *Jour-*

- nal of the North American Benthological Society* 16:425–438.
- Pringle, C.M., N. Hemphill, W.H. McDowell, A. Bednarek, and J.G. March. 1999. Linking species and ecosystems: differing biotic assemblages cause interstream differences in organic matter. *Ecology* 80:1860–1872.
- Pringle, C.M., M.C. Freeman, and B.J. Freeman. 2000. Regional effects of hydrologic alterations on riverine macrobiota in the New World: tropical–temperate comparisons. *BioScience* 50:807–823.
- Pringle, R.M., and K. Fox-Dobbs. 2008. Coupling of canopy and understory food webs by ground-dwelling predators. *Ecology Letters* 11:1328–1337.
- Pritchard, I.M., and R. James. 1984a. Leaf mines: their effect on leaf longevity. *Oecologia* 64:132–140.
- Pritchard, I.M., and R. James. 1984b. Leaf fall as a source of leaf miner mortality. *Oecologia* 64:140–142.
- Procter, W. 1946. Biological Survey of the Mount Desert Region: the Insect Fauna, with Reference to the Methods of Capture, Food Plants, the Flora and other Biological Features. Wistar Insitute of Anatomy and Biology, Philadelphia, PA.
- Progar, R.A., and T.D. Schowalter. 2002. Canopy arthropod assemblages along a precipitation and latitudinal gradient among Douglas-fir *Pseudotsuga menziesii* forests in the Pacific Northwest of the United States. *Ecography* 25:129–138.
- Progar, R.A., T.D. Schowalter, C.M. Freitag, and J.J. Morrell. 2000. Respiration from coarse woody debris as affected by moisture and saprotroph functional diversity in western Oregon. *Oecologia* 124:426–431.
- Punttila, P., Y. Haila, N. Niemelä, and T. Pajunen. 1994. Ant communities in fragments of old-growth taiga and managed surroundings. *Annales Zoologici Fennici* 31:131–144.
- Quesada, M., K. Bollman, and A.G. Stephenson. 1995. Leaf damage decreases pollen production and hinders pollen performance in *Cucurbita texana*. *Ecology* 76:437–443.
- Quesada, M., G.A. Sanchez-Azofeifa, M. Alvarez-Añorve, K.E. Stoner, L. Avila-Cabadilla, J. Calvo-Alvarado, A. Castillo, M.M. Espírito-Santo, M. Fagundes, G.W. Fernandes, J. Gamon, M. Lopezaraziza-Mikel, D. Lawrence, L.P.C. Morellato, J.S. Powers, F. de S. Neves, V. Rosas-Guerrero, R. Sayago, and G. Sanchez-Montoya. 2009. Succession and management of tropical dry forests in the Americas: review and new perspectives. *Forest Ecology and Management* 258:1014–1024.
- Rabatin, S.C., and B.R. Stinner. 1988. Indirect effects of interactions between VAM fungi and soil-inhabiting invertebrates on plant processes. *Agriculture, Ecosystems and Environment* 24:135–146.
- Rabb, R.L., G.K. DeFoliart, and G.G. Kennedy. 1984. An ecological approach to managing insect populations. In *Ecological Entomology* (C.B. Huffaker, and R.L. Rabb, Eds.), pp. 697–728. John Wiley & Sons, New York, NY.
- Rácz, V., and I. Bernath. 1993. Dominance conditions and population dynamics of *Lygus* (Het., Miridae) species in Hungarian maize stands (1976–1985), as functions of climatic conditions. *Journal of Applied Entomology* 115:511–518.
- Radeloff, V.C., D.J. Mladenoff, and M.S. Boyce. 2000. The changing relation of landscape patterns and jack pine budworm populations during an outbreak. *Oikos* 90:417–430.
- Raffa, K.F., T.W. Phillips, and S.M. Salom. 1993. Strategies and mechanisms of host colonization by bark beetles. In *Beetle–pathogen Interactions in Conifer Forests* (T.D. Schowalter, and G.M. Filip, Eds.), pp. 103–128. Academic Press, London, UK.
- Raffa, K.F., B.H. Aukema, B.J. Bentz, A.L. Carroll, J.A. Hicke, M.G. Turner, and W.H. Romme. 2008. Cross-scale drivers of natural disturbances prone to anthropogenic amplification: the dynamics of bark beetle eruptions. *BioScience* 58:501–517.
- Raich, J.W., R.D. Bowden, and P.A. Steudler. 1990. Comparison of two static chamber techniques for determining carbon dioxide efflux from forest soils. *Soil Science Society of America Journal* 54:1754–1757.
- Raimondo, S., M. Turcáni, J. Patoëka, and A.M. Liebhold. 2004. Interspecific synchrony among foliage-feeding forest Lepidoptera species and the potential role of generalist predators as synchronizing agents. *Oikos* 107:462–470.
- Rainey, R.C. 1963. Meteorology and the migration of desert locusts: applications of synoptic meteorology in locust control. *Anti-locust Memoir* 7.
- Rainey, R.C., and H.J. Sayer. 1953. Some recent developments in the use of aircraft against flying locust swarms. *Nature* 172:224–228.
- Ralph, S.G., H. Yueh, M. Friedmann, D. Aeschliman, J.A. Zeznik, C.C. Nelson, Y.S.N. Butterfield, R. Kirkpatrick, J. Liu, S.J.M. Jones, M.A. Marra, C.J. Douglas, K. Ritland, and J. Bohlmann. 2006. Conifer defence against insects: microarray gene expression profiling of Sitka spruce (*Picea sitchensis*) induced by mechanical wounding or feeding by spruce budworms (*Choristoneura occidentalis*) or white pine weevils (*Pissodes strobi*) reveals large-scale changes of the host transcriptome. *Plant, Cell and Environment* 29:1545–1570.
- Ramos-Elorduy, J. 2009. Anthro-entomophagy: cultures, evolution and sustainability. *Entomological Research* 39:271–288.
- Rand, E.L., and J.H. Redfield. 1894. Flora of Mount Desert Island, Maine. A Preliminary Catalogue of the Plants Growing on Mount Desert and the Adjacent Islands. John Wilson and Son, Cambridge, MA.
- Rankin, M.A., and J.C.A. Burchsted. 1992. The cost of migration in insects. *Annual Review of Entomology* 37:533–559.

- Ranson, H., C. Claudianos, F. Ortelii, C. Abgrall, J. Hemmingway, M.V. Sharakhova, M.F. Unger, F.H. Collins, and R. Feyereisen. 2002. Evolution of supergene families associated with insecticide resistance. *Science* 298:179–181.
- Rasmussen, E.M., and J.M. Wallace. 1983. Meteorological aspects of the El Niño/southern oscillation. *Science* 222:1195–1202.
- Rastetter, E.B., G.I. Ågren, and G.R. Shaver. 1997. Responses of N-limited ecosystems to increased CO<sub>2</sub>: a balanced-nutrition, coupled-element-cycles model. *Ecological Applications* 7:444–460.
- Rastetter, E.B., M.G. Ryan, G.R. Shaver, J.M. Melillo, K.J. Nadelhoffer, J.E. Hobbie, and J.D. Aber. 1991. A general biogeochemical model describing the responses of the C and N cycles in terrestrial ecosystems to changes in CO<sub>2</sub>, climate and N deposition. *Tree Physiology* 9:101–126.
- Raubenheimer, D., and S.J. Simpson. 1999. Integrating nutrition: a geometrical approach. *Entomologia Experimentalis et Applicata* 91:67–82.
- Raubenheimer, D., and S.J. Simpson. 2003. Nutrient balancing in grasshoppers: behavioural and physiological correlates of diet breadth. *Journal of Experimental Biology* 206:1669–1681.
- Raubenheimer, D., and D. Tucker. 1997. Associative learning by locusts: pairing of visual cues with consumption of protein and carbohydrate. *Animal Behaviour* 54:1449–1459.
- Raupp, M.J., P.M. Shrewsbury, and D.A. Herms. 2010. Ecology of herbivorous arthropods in urban landscapes. *Annual Review of Entomology* 55:19–38.
- Raven, J.A. 1983. Phytophages of xylem and phloem: a comparison of animal and plant sap-feeders. *Advances in Ecological Research* 13:136–204.
- Reagan, D.P.G.R., R.B. Camilo, and Waide. 1996. The community food web: major properties and patterns of organization. In *The Food Web of a Tropical Rain Forest* (D.P. Reagan, and R.B. Waide, Eds.), pp. 462–488. University of Chicago Press, Chicago, IL.
- Reay-Jones, F.P.F., M.O. Way, M. Sétamou, B.L. Legendre, and T.E. Reagan. 2003. Resistance to the Mexican rice borer (Lepidoptera: Crambidae) among Louisiana and Texas sugarcane cultivars. *Journal of Economic Entomology* 96:1929–1934.
- Reay-Jones, F.P.F., L.T. Wilson, M.O. Way, T.E. Reagan, and C.E. Carlton. 2007. Movement of Mexican rice borer (Lepidoptera: Crambidae) through the Texas rice belt. *Journal of Economic Entomology* 100:54–60.
- Regal, R.J. 1982. Pollination by wind and animals: ecology of geographic patterns. *Annual Review of Ecology and Systematics* 13: 497–424.
- Reice, S.R. 1985. Experimental disturbance and the maintenance of species diversity in a stream community. *Oecologia* 67:90–97.
- Reichle, D.E. 1968. Relation of body size to food intake, oxygen consumption, and trace element metabolism in forest floor arthropods. *Ecology* 49:538–542.
- Reichle, D.E., and D.A. Crossley, Jr. 1967. Investigation on heterotrophic productivity in forest insect communities. In *Secondary Productivity of Terrestrial Ecosystems: Principles and Methods* (K. Petrusewicz, Ed.), pp. 563–587. Pastwowe Wydawnictwo Naukowe, Warszawa, Poland.
- Reichle, D.E., M.H. Shanks, and D.A. Crossley, Jr. 1969. Calcium, potassium, and sodium content of forest floor arthropods. *Annals of the Entomological Society of America* 62:57–62.
- Reichle, D.E., R.A. Goldstein, R.I. Van Hook, and G.J. Dodson. 1973. Analysis of insect consumption in a forest canopy. *Ecology* 54:1076–1084.
- Renwick, J.A.A. 2002. The chemical world of crucivores: lures, treats and traps. *Entomologia Experimentalis et Applicata* 104:35–42.
- Reusch, T.B.H., A. Ehlers, A. Hämmerli, and B. Worm. 2005. Ecosystem recovery after climatic extremes enhanced by genotypic diversity. *Proceedings of the National Academy of Science, USA* 102:2826–2831.
- Reynolds, A.M., A.D. Smith, R. Menzel, U. Greggers, D.R. Reynolds, and J.R. Riley. 2007. Displaced honey bees perform optimal scale-free search flights. *Ecology* 88:1955–1961.
- Reynolds, B.C., D.A. Crossley, Jr., and M.D. Hunter. 2003. Response of soil invertebrates to forest canopy inputs along a productivity gradient. *Pedobiologia* 47:127–139.
- Rhoades, D.F. 1977. The antiherbivore chemistry of *Larrea*. In *Creosote Bush: Biology and Chemistry of Larrea in New World Deserts* (T.J. Mabry, J.H. Hunziker, and D.R. DiFeo Jr., Eds.), pp. 135–175. Dowden, Hutchinson & Ross, Inc., Stroudsburg, PA.
- Rhoades, D.F. 1983. Responses of alder and willow to attack by tent caterpillars and webworms: evidence for pheromonal sensitivity of willows. In *Plant Resistance to Insects* (P.A. Hedin, Ed.), pp. 55–68. ACS Symposium Series 208, American Chemical Society, Washington, DC.
- Ribeiro, S.P., H.R. Pimenta, and G.W. Fernandes. 1994. Herbivory by chewing and sucking insects on *Tabebuia ochracea*. *Biotropica* 26:302–307.
- Rice, B., and M. Westoby. 1986. Evidence against the hypothesis that ant-dispersed seeds reach nutrient-enriched microsites. *Ecology* 67:1270–1274.
- Richardson, B.A., and G.A. Hull. 2000. Insect colonization sequences in bracts of *Heliconia caribaea* in Puerto Rico. *Ecological Entomology* 25:460–466.
- Richardson, B.A., M.J. Richardson, F.N. Scatena, and W.H. McDowell. 2000a. Effects of nutrient availability and other elevational changes on bromeliad populations and their invertebrate communities in

- a humid tropical forest in Puerto Rico. *Journal of Tropical Ecology* 16:167–188.
- Richardson, B.A., C. Rogers, and M.J. Richardson. 2000b. Nutrients, diversity, and community structure of two phytotelm systems in a lower montane forest, Puerto Rico. *Ecological Entomology* 25:348–356.
- Richardson, S.J., M.C. Press, A.N. Parsons, and S.E. Hartley. 2002. How do nutrients and warming impact on plant communities and their insect herbivores? A 9-year study from a sub-Arctic heath. *Journal of Ecology* 90:544–556.
- Richerson, J.V., and P.E. Boldt. 1995. Phytophagous insect fauna of *Flourensia cernua* (Asteraceae: Heliantheae) in trans-Pecos Texas and Arizona. *Environmental Entomology* 24:588–594.
- Richter, M.R. 1990. Hunting social wasp interactions: influence of prey size, arrival order, and wasp species. *Ecology* 71:1018–1030.
- Ricketts, T.H. 2004. Tropical forest fragments enhance pollinator activity in nearby coffee crops. *Conservation Biology* 18:1262–1271.
- Ricketts, T.H., J. Regetz, I. Steffan-Dewenter, S.A. Cunningham, C. Kremen, A. Bogdanski, B. Gemmill-Herren, S.S. Greenleaf, A.M. Klein, M.M. Mayfield, L.A. Morandin, A. Ochieng, and B.F. Viana. 2008. Landscape effects on crop pollinator services: are there general patterns? *Ecology Letters* 11:499–515.
- Rickson, F.R. 1971. Glycogen plastids in Müllerian body cells of *Cecropia peltata*—a higher green plant. *Science* 173:344–347.
- Rickson, F.R. 1977. Progressive loss of ant-related traits of *Cecropia peltata* on selected Caribbean islands. *American Journal of Botany* 64:585–592.
- Rickson, F.R., and M.M. Rickson. 1998. The cashew nut, *Anacardium occidentale* (Anacardiaceae), and its perennial association with ants: extrafloral nectary location and the potential for ant defense. *American Journal of Botany* 85:835–849.
- Ridsdill-Smith, T.J., and A.A. Kirk. 1985. Selecting dung beetles (Scarabaeinae) from Spain for bushfly control in south-western Australia. *Entomophaga* 30:217–223.
- Ries, L., and W.F. Fagan. 2003. Habitat edges as a potential ecological trap for an insect predator. *Ecological Entomology* 28:567–572.
- Riley, C.V. 1878. First Annual Report of the United States Entomological Commission for the Year 1877 Relating to the Rocky Mountain Locust and the Best Methods of Preventing its Injuries and of Guarding Against its Invasions, in Pursuance of an Appropriation Made by Congress for this Purpose. US Department of Agriculture, Washington, DC.
- Riley, C.V. 1880. Second Report of the United States Entomological Commission for the Years 1878 and 1879 Relating to the Rocky Mountain Locust and the Western Cricket and Treating of the Best Means of Subduing the Locust in its Permanent Breeding Grounds, With a View of Preventing its Migrations into the More Fertile Portions of the Trans-Mississippi Country, in Pursuance of Appropriations Made by Congress for this Purpose. US Department of Agriculture, Washington, DC.
- Riley, C.V. 1883. Third Report of the United States Entomological Commission, Relating to the Rocky Mountain Locust, the Western Cricket, the Armyworm, Canker Worms, and the Hessian Fly, Together with Descriptions of Larvae of Injurious Forest Insects, Studies on the Embryological Development of the Locust and of Other Insects, and on the Systematic Position of the Orthoptera in Relation to Other Orders of Insects. US Department of Agriculture, Washington, DC.
- Riley, C.V. 1885. Fourth Report of the United States Entomological Commission, Being a Revised Edition of Bulletin No. 3, and the Final Report on the Cotton Worm, Together with a Chapter on the Boll Worm. US Department of Agriculture, Washington, DC.
- Riley, C.V. 1893. Predaceous and parasitic insects in applied entomology. *Insect Life* 6:130–141.
- Riley, C.V., and L.O. Howard. 1890. The imported gypsy moth (*Ocneria dispar* L.). *Insect Life* 2:208–211.
- Riley, C.V., and G. Vasey. 1870. Imported insects and native American insects. *American Entomologist* 2:110–112.
- Riley, J.R., A.D. Smith, D.R. Reynolds, A.S. Edwards, J.L. Osborne, I.H. Williams, N.L. Carreck, and G.M. Poppy. 1996. Tracking bees with harmonic radar. *Nature* 379:29–30.
- Risch, A.C., M.F. Jurgensen, M. Schütz, and D.S. Page-Dumroese. 2005. The contribution of red wood ants to soil C and N pools and CO<sub>2</sub> emissions in subalpine forests. *Ecology* 85:419–430.
- Risch, S. 1980. The population dynamics of several herbivorous beetles in a tropical agroecosystem: the effect of intercropping corn, beans and squash in Costa Rica. *Journal of Applied Ecology* 17:593–612.
- Risch, S.J. 1981. Insect herbivore abundance in tropical monocultures and polycultures: an experimental test of two hypotheses. *Ecology* 62:1325–1340.
- Risley, L.S., and D.A. Crossley, Jr. 1993. Contribution of herbivore-caused greenfall to litterfall nitrogen flux in several southern Appalachian forested watersheds. *American Midland Naturalist* 129:67–74.
- Rissing, S.W. 1986. Indirect effects of granivory by harvester ants: plant species composition and reproductive increase near ant nests. *Oecologia* 68:231–234.
- Ritchie, M.E. 2000. Nitrogen limitation and trophic vs. abiotic influences on insect herbivores in a temperate grassland. *Ecology* 81:1601–1612.



- Ritchie, M.E., D. Tilman, and J.M.H. Knops. 1998. Herbivore effects on plant and nitrogen dynamics in oak savanna. *Ecology* 79:165–177.
- Ritland, D.B., and L.P. Brower. 1991. The viceroy butterfly is not a Batesian mimic. *Nature* 350:497–498.
- Ritter, Jr., H. 1964. Defense of mate and mating chamber in a wood roach. *Science* 143:1459–1460.
- Rivers, D.B., R.E. Lee, Jr., and D.L. Denlinger. 2000. Cold hardness of the fly pupal parasitoid *Nasonia vitripennis* is enhanced by its host *Sarcophaga crassipalpis*. *Journal of Insect Physiology* 46:99–106.
- Roberds, J.H., F.P. Hain, and L.B. Nunnally. 1987. Genetic structure of southern pine beetle populations. *Forest Science* 33:52–69.
- Robertson, A.I., R. Giddins, and T.J. Smith. 1990. Seed predation by insects in tropical mangrove forests: extent and effects on seed viability and the growth of seedlings. *Oecologia* 83:213–219.
- Robinson, M.H. 1969. The defensive behaviour of some orthopteroid insects from Panama. *Transactions of the Royal Entomological Society London* 121:281–303.
- Robinson, M.H., and B.C. Robinson. 1974. Adaptive complexity: the thermoregulatory postures of the golden-web spider, *Nephila clavipes*, at low latitudes. *American Midland Naturalist* 92:386–396.
- Rodgers, H.L., M.P. Brakke, and J.J. Ewel. 1995. Shoot damage effects on starch reserves of *Cedrela odorata*. *Biotropica* 27:71–77.
- Rodriguez, J.M. (Ed.) 1972. Insect and Mite Nutrition: Significance and Implications in Ecology and Pest Management. North-Holland Publishing Co., Amsterdam, The Netherlands.
- Rodriguez-Saona, C., J.A. Chalmers, S. Raj, and J.S. Thaler. 2005. Induced plant responses to multiple damagers: differential effects on an herbivore and its parasitoid. *Oecologia* 143:566–577.
- Roelofs, W.L. 1995. Chemistry of sex attraction. *Proceedings of the National Academy of Sciences, USA* 92:44–49.
- Roland, J. 1993. Large-scale forest fragmentation increases the duration of tent caterpillar outbreak. *Oecologia* 93:25–30.
- Roland, J., and W.J. Kaupp. 1995. Reduced transmission of forest tent caterpillar (Lepidoptera: Lasiocampidae) nuclear polyhedrosis virus at the forest edge. *Environmental Entomology* 24:1175–1178.
- Roland, J., and P.D. Taylor. 1997. Insect parasitoid species respond to forest structure at different spatial scales. *Nature* 386:710–713.
- Romeis, J., D. Bartsch, F. Bigler, M.P. Candolfi, M.M.C. Gielkens, S.E. Hartley, R.L. Hellmich, J.E. Huesing, P.C. Jepson, R. Layton, H. Quemada, A. Raybould, R.I. Rose, J. Schiemann, M.K. Sears, A.M. Shelton, J. Sweet, Z. Vaituzis, and J.D. Wolt. 2008. Assessment of risk of insect-resistant transgenic crops to nontarget arthropods. *Nature Biotechnology* 26:203–208.
- Romme, W.H., D.H. Knight, and J.B. Yavitt. 1986. Mountain pine beetle outbreaks in the Rocky Mountains: regulators of primary productivity? *American Naturalist* 127:484–494.
- Romoser, W.S., and J.G. Stoffolano, Jr. 1998. The Science of Entomology, 4th Ed. McGraw-Hill, Boston, MA.
- Root, R.B. 1967. The niche exploitation pattern of the blue-gray gnatcatcher. *Ecological Monographs* 37:317–350.
- Root, R.B. 1973. Organization of a plant–arthropod association in simple and diverse habitats: the fauna of collards (*Brassica oleracea*). *Ecological Monographs* 43:95–124.
- Rosenheim, J.A. 2005. Intraguild predation of *Orius tristicolor* by *Geocoris* spp. and the paradox of irruptive spider mite dynamics in California cotton. *Biological Control* 32:172–179.
- Rosenthal, G.A., and D.H. Janzen (Eds.) 1979. Herbivores: Their Interactions with Secondary Plant Metabolites. Academic Press, New York, NY.
- Rosenzweig, M.L., and Z. Abramsky. 1993. How are diversity and productivity related? In *Species Diversity in Ecological Communities: Historical and Geographic Perspectives* (R.E. Ricklefs, and D. Schluter, Eds.), pp. 52–65. University of Chicago Press, Chicago, IL.
- Rosi-Marshall, E.J., J.L. Tank, T.V. Royer, M.R. Whiles, M. Evans-White, C. Chambers, N.A. Griffiths, J. Pokelsek, and M.L. Stephen. 2007. Toxins in transgenic crop byproducts may affect headwater stream ecosystems. *Proceedings of the National Academy of Sciences, USA* 104:16204–16208.
- Rotem, K., A.A. Agrawal, and L. Kott. 2003. Parental effects in *Pieris rapae* in response to variation in food quality: adaptive plasticity across generations? *Ecological Entomology* 28:211–218.
- Roth, J.P., A. MacQueen, and D.E. Bay. 1988. Predation by the introduced phoretic mite, *Macrocheles peregrinus* (Acari: Macrochelidae), on the buffalo fly, *Haematobia irritans exigua* (Diptera: Muscidae), in Australia. *Environmental Entomology* 17:603–607.
- Roth, S.K., and R.L. Lindroth. 1994. Effects of CO<sub>2</sub>-mediated changes in paper birch and white pine chemistry on gypsy moth performance. *Oecologia* 98:133–138.
- Roubik, D.W. 1989. Ecology and Natural History of Tropical Bees. Cambridge University Press, Cambridge, UK.
- Roubik, D.W. 1993. Tropical pollinators in the canopy and understory: field data and theory for stratum “preferences”. *Journal of Insect Behavior* 6:659–673.
- Rousseaux, M.C., R. Julkunen-Tiitto, P.S. Searles, A.L. Scopel, P.J. Aphalo, and C.L. Ballaré. 2004. Solar UV-B radiation affects leaf quality and insect herbivory in the southern beech tree *Nothofagus antarctica*. *Oecologia* 138:505–512.

- Roussel, J.S., and D.F. Clower. 1957. Resistance to the chlorinated hydrocarbon insecticides in the boll weevil. *Journal of Economic Entomology* 50:463–468.
- Royama, T. 1984. Population dynamics of the spruce budworm *Choristoneura fumiferana*. *Ecological Monographs* 54:429–462.
- Royama, T. 1992. Analytical Population Dynamics. Chapman & Hall, London, UK.
- Ruangpanit, N. 1985. Percent crown cover related to water and soil losses in mountainous forest in Thailand. In *Soil Erosion and Conservation* (S.A. El-Swaify, W.C. Moldenhauer, and A. Lo, Eds.), pp. 462–471. Soil Conservation Society of America, Ankeny, IA.
- Rubenstein, D.I. 1992. The greenhouse effect and changes in animal behavior: effects on social structure and life-history strategies. In *Global Warming and Biological Diversity* (R.L. Peters, and T.E. Lovejoy, Eds.), pp. 180–192. Yale University Press, New Haven, CT.
- Ruberson, J.R., T.J. Kring, and N. Elkassabany. 1998. Overwintering and the diapause syndrome of predatory Heteroptera. In *Predatory Heteroptera: Their Ecology and Use In Biological Control* (M. Coll, and J.R. Ruberson, Eds.), pp. 49–69. Proc. Thomas Say Publ. in Entomol., Entomological Society of America, Lanham, MD.
- Rudd, W.G., and R.W. Gandour. 1985. Diffusion model for insect dispersal. *Journal of Economic Entomology* 78:295–301.
- Ruel, J., and T.G. Whitham. 2002. Fast-growing juvenile pinyons suffer greater herbivory when mature. *Ecology* 83:2691–2699.
- Rudinsky, J.A. and L.C. Ryker. 1976. Olfactory and auditory signals mediating behavioral patterns of bark beetles. In *Coll. Internat., Centre National de la Recherche Scientifique*, pp. 195–207, No. 265, Paris, France.
- Running, S.W., and S.T. Gower. 1991. FOREST-BGC, a general model of forest ecosystem processes for regional applications. II. Dynamic carbon allocation and nitrogen budgets. *Tree Physiology* 9:147–160.
- Russell, T.L., and B.H. Kay. 2008. Biologically based insecticides for the control of immature Australian mosquitoes: a review. *Australian Journal of Entomology* 47:232–242.
- Rykiel, E.J., M.C. Saunders, T.L. Wagner, D.K. Loh, R.H. Turnbow, L.C. Hu, P.E. Pulley, and R.N. Coulson. 1984. Computer-aided decision making and information accessing in pest management systems, with emphasis on the southern pine beetle (Coleoptera: Scolytidae). *Journal of Economic Entomology* 77:1073–1082.
- Rykken, J.J., D.E. Capen, and S.P. Mahabir. 1997a. Ground beetles as indicators of land type diversity in the Green Mountains of Vermont. *Conservation Biology* 11:522–530.
- Rykken, J.J., A.R. Moldenke, and D.H. Olson. 2007b. Headwater riparian forest-floor invertebrate communities associated with alternative forest management practices. *Ecological Applications* 17:1168–1183.
- Rykken, J.J., S.S. Chan, and A.R. Moldenke. 2007b. Headwater riparian microclimate patterns under alternative forest management treatments. *Forest Science* 53:270–280.
- Sabo, J.L., R. Sponseller, M. Dixon, K. Gade, T. Harms, J. Heffernan, A. Jani, G. Katz, C. Soykan, J. Watts, and J. Welter. 2005. Riparian zones increase regional species richness by harboring different, not more, species. *Ecology* 86:56–62.
- Sackville Hamilton, C.A.G., J.M. Cherrett, J.B. Ford, G.R. Sagar, and R. Whitbread. 1991. A modular rhizotron for studying soil organisms: construction and establishment. In *Plant Root Growth: an Ecological Perspective* (D. Atkinson, Ed.), pp. 49–59. Blackwell Scientific, London, UK.
- St. Pierre, M.J., and S.D. Hendrix. 2003. Movement patterns of *Rhysomatus lineaticollis* Say (Coleoptera: Curculionidae) within and among *Asclepias syriaca* (Asclepiadaceae) patches in a fragmented landscape. *Ecological Entomology* 28:579–586.
- St. Pierre, M.J., S.D. Hendrix, and C.K. Lewis. 2005. Dispersal ability and host-plant characteristics influence spatial population structure of monophagous beetles. *Ecological Entomology* 30:105–115.
- Sakai, S., K. Momose, T. Yumoto, M. Kato, and T. Inoue. 1999. Beetle pollination of *Shorea parvifolia* (section *Mutica*, Dipterocarpaceae) in a general flowering period in Sarawak, Malaysia. *American Journal of Botany* 86:62–69.
- Salati, E. 1987. The forest and the hydrologic cycle. In *The Geophysiology of Amazonia: Vegetation and Climate Interactions* (R.E. Dickinson, Ed.), pp. 273–296. John Wiley & Sons, New York, NY.
- Salick, J., R. Herrera, and C.F. Jordan. 1983. Termitaria: nutrient patchiness in nutrient-deficient rain forests. *Biotropica* 15:1–7.
- Sallabanks, R., and S.P. Courtney. 1992. Frugivory, seed predation, and insect-vertebrate interactions. *Annual Review of Entomology* 37:377–400.
- Salo, J., R. Kallioloa, I. Häkkinen, Y. Mäkinen, P. Niemelä, M. Puhakka, and P.D. Coley. 1986. River dynamics and the diversity of Amazon lowland forest. *Nature* 322:254–258.
- Salt, D.T., P. Fenwick, and J.B. Whittaker. 1996. Interspecific herbivore interactions in a high CO<sub>2</sub> environment: root and shoot aphids feeding on *Caramine*. *Oikos* 77:326–330.
- Saltzman, K.D., M.P. Giovanini, C. Zheng, and C.E. Williams. 2008. Virulent Hessian fly larvae manipulate the free amino acid content of host wheat plants. *Journal of Chemical Ecology* 34:1401–1410.
- Samways, M.J. 1995. Southern hemisphere insects: their variety and the environmental pressures upon

- them. In *Insects in a Changing Environment* (R. Harrington, and N.E. Stork, Eds.), pp. 297–320. Academic Press, London, UK.
- Samways, M.J., P.M. Caldwell, and R. Osborn. 1996. Ground-living invertebrate assemblages in native, planted and invasive vegetation in South Africa. *Agriculture, Ecosystems and Environment* 59:19–32.
- Sanders, D., and C. Platner. 2007. Intraguild interactions between spiders and ants and top-down control in a grassland food web. *Oecologia* 150:611–624.
- Sanders, N.J., N.J. Gotelli, N.E. Heller, and D.M. Gordon. 2003. Community disassembly by an invasive species. *Proceedings of the National Academy of Sciences, USA* 100:2474–2477.
- Sanders, N.J., J.F. Weltzin, G.M. Crutsinger, M.C. Fitzpatrick, M.A. Nuñez, C.M. Oswalt, and K.E. Lane. 2007. Insects mediate the effects of propagule supply and resource availability on a plant invasion. *Ecology* 88:2383–2391.
- Sanderson, M.G. 1996. Biomass of termites and their emissions of methane and carbon dioxide: a global database. *Global Biogeochemical Cycles* 10:543–557.
- Sandlin, E.A., and M.R. Willig. 1993. Effects of age, sex, prior experience, and intraspecific food variation on diet composition of a tropical folivore (Phasmatodea: Phasmatidae). *Environmental Entomology* 22:625–633.
- Sanson, D.W., A.A. DeRosa, G.R. Oremus, and L.D. Foil. 2003. Effect of horn fly and internal parasite control on growth of beef heifers. *Veterinary Parasitology* 117:291–300.
- Santos, P.F., and W.G. Whitford. 1981. The effects of microarthropods on litter decomposition in a Chihuahuan Desert ecosystem. *Ecology* 62:654–663.
- Santos, P.F., J. Phillips, and W.G. Whitford. 1981. The role of mites and nematodes in early stages of buried litter decomposition in a desert. *Ecology* 62:664–669.
- Šantrůčková, H., M.I. Bird, J. Frouz, V. Šustr, and K. Tajovský. 2000. Natural abundance of  $^{13}\text{C}$  in leaf litter as related to feeding activity of soil invertebrates and microbial mineralization. *Soil Biology and Biochemistry* 32:1793–1797.
- Sarmiento, J.L., and C. Le Quéré. 1996. Oceanic carbon dioxide uptake in a model of century-scale global warming. *Science* 274:1346–1350.
- Sartwell, C., and R.E. Stevens. 1975. Mountain pine beetle in ponderosa pine: prospects for silvicultural control in second-growth stands. *Journal of Forestry* 73:136–140.
- Savage, H.M., M.L. Niebylski, G.C. Smith, C.J. Mitchell, and G.B. Craig, Jr. 1993. Host-feeding patterns of *Aedes albopictus* (Diptera: Culicidae) at a temperate North American site. *Journal of Medical Entomology* 30:27–34.
- Savely, Jr., H.E. 1939. Ecological relations of certain animals in dead pine and oak logs. *Ecological Monographs* 9:321–385.
- Scatena, F.N., S. Moya, C. Estrada, and J.D. China. 1996. The first five years in the reorganization of aboveground biomass and nutrient use following Hurricane Hugo in the Bisley Experimental Watersheds, Luquillo Experimental Forest, Puerto Rico. *Biotropica* 28:424–440.
- Scheiner, S.M., and M.R. Willig. 2008. A general theory of ecology. *Theoretical Ecology* 1:21–28.
- Schell, S.P., and J.A. Lockwood. 1997. Spatial characteristics of rangeland grasshopper (Orthoptera: Acrididae) population dynamics in Wyoming: implications for pest management. *Environmental Entomology* 26:1056–1065.
- Scheu, S., and M. Falca. 2000. The soil food web of two beech forests (*Fagus sylvatica*) of contrasting humus type: stable isotope analysis of a macro- and a mesofauna-dominated community. *Oecologia* 123:285–296.
- Schiff, H. 1991. Modulation of spike frequencies by varying the ambient magnetic field and magnetite candidates in bees (*Apis mellifera*). *Comparative Biochemistry and Physiology A* 100:975–985.
- Schlesinger, W.H., J.F. Reynolds, G.L. Cunningham, L.F. Huenneke, W.M. Jarrell, R.A. Virginia, and W.G. Whitford. 1990. Biological feedbacks in global desertification. *Science* 247:1043–1048.
- Schmelz, E.A., R.J. Brebeno, T.E. Ohnmeiss, and W.S. Bowers. 2002. Interactions between *Spinacia oleracea* and *Bradysia impatiens*: a role for phytoecdysteroids. *Archives of Insect Biochemistry and Physiology* 51:204–221.
- Schmelz, E.A., M.J. Carroll, S. LeClere, S.M. Phipps, J. Meredith, P.S. Chourey, H.T. Alborn, and P.E.A. Teal. 2006. Fragments of ATP synthase mediate plant perception of insect attack. *Proceedings of the National Academy of Sciences, USA* 103:8894–8899.
- Schmelz, E.A., S. LeClere, M.J. Carroll, H.T. Alborn, and P.E.A. Teal. 2007. Cowpea chloroplastic ATP synthase is the source of multiple plant defense elicitors during insect herbivory. *Plant Physiology* 144:793–805.
- Schmidt, D.D., C. Voelckel, M. Hartl, S. Schmidt, and I.T. Baldwin. 2005. Specificity in ecological interactions. Attack from the same lepidopteran herbivore results in species-specific transcriptional responses in two solanaceous host plants. *Plant Physiology* 138:1763–1773.
- Schmidt, J.O. 1982. Biochemistry of insect venoms. *Annual Review of Entomology* 27:339–368.
- Schmitz, O.J. 2007. Predator diversity and trophic interactions. *Ecology* 88:2415–2426.
- Schneider, J.C. 1999. Dispersal of a highly vagile insect in a heterogeneous environment. *Ecology* 80:2740–2749.
- Schnierla, T.C. 1953. Modifiability in insect behavior. In *Insect Physiology* (K.D. Roeder, Ed.), pp. 723–747. John Wiley & Sons, New York, NY.

- Schoener, T.W. 1982. The controversy over interspecific competition. *American Scientist* 70:586–595.
- Scholte, E.-J., K. Ng'habi, J. Kihonda, W. Takken, K. Paaijmans, S. Abdulla, G.F. Killeen, and B.G.J. Knols. 2005. An entomopathogenic fungus for control of adult African malaria mosquitoes. *Science* 308:1641–1642.
- Schöning, C., W.M. Njagi, and N.R. Franks. 2005. Temporal and spatial patterns in the emigrations of the army ant *Dorylus (Anomma) molestus* in the montane forest of Mt. Kenya. *Ecological Entomology* 30:532–540.
- Schöpf, R., C. Mignat, and P. Hedden. 1982. As to the food quality of spruce needles for forest damaging insects: 18: Resorption of secondary plant metabolites by the sawfly, *Gilpinia hercyniae* Htg. (Hym., Diprionidae). *Zeitschrift für angewandte Entomologie* 93:244–257.
- Schowalter, T.D. 1981. Insect herbivore relationship to the state of the host plant: biotic regulation of ecosystem nutrient cycling through ecological succession. *Oikos* 37:126–130.
- Schowalter, T.D. 1985. Adaptations of insects to disturbance. In *The Ecology of Natural Disturbance and Patch Dynamics* (S.T.A. Pickett, and P.S. White, Eds.), pp. 235–252. Academic Press, Orlando, FL.
- Schowalter, T.D. 1989. Canopy arthropod community structure and herbivory in old-growth and regenerating forests in western Oregon. *Canadian Journal of Forest Research* 19:318–322.
- Schowalter, T.D. 1993. Cone and seed insect phenology in a Douglas-fir seed orchard during three years in western Oregon. *Journal of Economic Entomology* 87:758–765.
- Schowalter, T.D. 1994. Invertebrate community structure and herbivory in a tropical rainforest canopy in Puerto Rico following Hurricane Hugo. *Biotropica* 26:312–319.
- Schowalter, T.D. 1995. Canopy arthropod communities in relation to forest age and alternative harvest practices in western Oregon. *Forest Ecology and Management* 78:115–125.
- Schowalter, T.D. 2000. Insects as regulators of ecosystem development. In *Invertebrates as Webmasters in Ecosystems* (D.C. Coleman, and P. Hendrix, Eds.), pp. 99–114. CAB International, Wallingford, UK.
- Schowalter, T.D. 2008. Insect herbivore responses to management practices in conifer forests in North America. *Journal of Sustainable Forestry* 26:204–222.
- Schowalter, T.D., and D.A. Crossley, Jr. 1982. Bioelimination of  $^{51}\text{Cr}$  and  $^{85}\text{Sr}$  by cockroaches, *Gromphadorhina portentosa* (Orthoptera: Blaberidae), as affected by mites, *Gromphadorholaelaps schaeferi* (Parasitiformes: Laelapidae). *Annals of the Entomological Society of America* 75:158–160.
- Schowalter, T.D., and D.A. Crossley, Jr. 1983. Forest canopy arthropods as sodium, potassium, magnesium and calcium pools in forests. *Forest Ecology and Management* 7:143–148.
- Schowalter, T.D., and D.A. Crossley, Jr. 1988. Canopy arthropods and their response to forest disturbance. In *Forest Hydrology and Ecology at Coweeta* (W.T. Swank, and D.A. Crossley Jr., Eds.), pp. 207–218. Springer-Verlag, New York, NY.
- Schowalter, T.D., and L.M. Ganio. 1998. Vertical and seasonal variation in canopy arthropod communities in an old-growth conifer forest in southwestern Washington, USA. *Bulletin of Entomological Research* 88:633–640.
- Schowalter, T.D., and L.M. Ganio. 1999. Invertebrate communities in a tropical rain forest canopy in Puerto Rico following Hurricane Hugo. *Ecological Entomology* 24:1–11.
- Schowalter, T.D., and L.M. Ganio. 2003. Diel, seasonal and disturbance-induced variation in invertebrate assemblages. In *Arthropods of Tropical Forests* (Y. Basset, V. Novotny, S.E. Miller, and R.L. Kitching, Eds.), pp. 315–328. Cambridge University Press, Cambridge, UK.
- Schowalter, T.D., and M.D. Lowman. 1999. Forest herbivory by insects. In *Ecosystems of the World: Ecosystems of Disturbed Ground* (L.R. Walker, Ed.), pp. 269–285. Elsevier, Amsterdam, The Netherlands.
- Schowalter, T.D., and T.E. Sabin. 1991. Litter microarthropod responses to canopy herbivory, season and decomposition in litterbags in a regenerating conifer ecosystem in western Oregon. *Biology and Fertility of Soils* 11:93–96.
- Schowalter, T.D., and P. Turchin. 1993. Southern pine beetle infestation development: interaction between pine and hardwood basal areas. *Forest Science* 39:201–210.
- Schowalter, T.D., and W.G. Whitford. 1979. Territorial behavior of *Boottettix argentatus* Bruner (Orthoptera: Acrididae). *American Midland Naturalist* 102:182–184.
- Schowalter, T.D., W.G. Whitford, and R.B. Turner. 1977. Bioenergetics of the range caterpillar, *Hemileuca oliviae* (Ckll.). *Oecologia* 28:153–161.
- Schowalter, T.D., R.N. Coulson, and D.A. Crossley, Jr. 1981a. Role of southern pine beetle and fire in maintenance of structure and function of the southeastern coniferous forest. *Environmental Entomology* 10:821–825.
- Schowalter, T.D., D.N. Pope, R.N. Coulson, and W.S. Fargo. 1981b. Patterns of southern pine beetle (*Dendroctonus frontalis* Zimm.) infestation enlargement. *Forest Science* 27:837–849.
- Schowalter, T.D., J.W. Webb, and D.A. Crossley, Jr. 1981c. Community structure and nutrient content of canopy arthropods in clearcut and uncut forest ecosystems. *Ecology* 62:1010–1019.
- Schowalter, T.D., R.N. Coulson, R.H. Turnbow, and W.S. Fargo. 1982. Accuracy and precision of procedures for estimating populations of the southern pine beetle (Coleoptera: Scolytidae) by using host

- tree correlates. *Journal of Economic Entomology* 75:1009–1016.
- Schowalter, T.D., W.W. Hargrove, and D.A. Crossley, Jr. 1986. Herbivory in forested ecosystems. *Annual Review of Entomology* 31:177–196.
- Schowalter, T.D., T.E. Sabin, S.G. Stafford, and J.M. Sexton. 1991. Phytophage effects on primary production, nutrient turnover, and litter decomposition of young Douglas-fir in western Oregon. *Forest Ecology and Management* 42:229–243.
- Schowalter, T.D., Y.L. Zhang, and T.E. Sabin. 1998. Decomposition and nutrient dynamics of oak *Quercus* spp. logs after five years of decomposition. *Ecography* 21:3–10.
- Schowalter, T.D., D.C. Lightfoot, and W.G. Whitford. 1999. Diversity of arthropod responses to host-plant water stress in a desert ecosystem in southern New Mexico. *American Midland Naturalist* 142:281–290.
- Schowalter, T.D., Y.L. Zhang, and J.J. Rykken. 2003. Litter invertebrate responses to variable density thinning in western Washington forest. *Ecological Applications* 13:1204–1211.
- Schroll, H. 1994. Energy-flow and ecological sustainability in Danish agriculture. *Agriculture, Ecosystems and Environment* 51:301–310.
- Schultz, J.C. 1983. Habitat selection and foraging tactics of caterpillars in heterogeneous trees. In *Variation in Plants and Herbivores in Natural and Managed Systems* (R.F. Denno, and M.S. McClure, Eds.), pp. 61–90. Academic Press, New York, NY.
- Schultz, J.C. 1988. Many factors influence the evolution of herbivore diets, but plant chemistry is central. *Ecology* 69:896–897.
- Schultz, J.C., and H.M. Appel. 2004. Cross-kingdom cross-talk: hormones shared by plants and their insect herbivores. *Ecology* 85:70–77.
- Schulze, E.D., and H.A. Mooney (Eds.) 1993. Biodiversity and Ecosystem Function. Springer-Verlag, Berlin, Germany.
- Schupp, E.W. 1988. Seed and early seedling predation in the forest understory and in treefall gaps. *Oikos* 51:71–78.
- Schupp, E.W., and D.H. Feener, Jr. 1991. Phylogeny, lifeform, and habitat dependence of ant-defended plants in a Panamanian forest. In *Ant-plant Interactions* (C.R. Huxley, and D.F. Cutler, Eds.), pp. 175–197. Oxford University Press, Oxford, UK.
- Schütz, M., C. Kretz, L. Dekoninck, M. Iravani, and A.C. Risch. 2008. Impact of *Formica exsecta* Nyl. on seed bank and vegetation patterns in a subalpine grassland ecosystem. *Journal of Applied Entomology* 132:295–305.
- Schütz, S., B. Weissbecker, H.E. Hummel, K.-H. Apel, H. Schmitz, and H. Bleckmann. 1999. Insect antenna as a smoke detector. *Nature* 398:298–299.
- Schuur, E.A.G., O.A. Chadwick, and P.A. Matson. 2001. Carbon cycling and soil carbon storage in mesic to wet Hawaiian montane forests. *Ecology* 82:3182–3196.
- Schwachtje, J., and I.T. Baldwin. 2008. Why does herbivore attack reconfigure primary metabolism? *Plant Physiology* 146:845–851.
- Schwachtje, J., P.E.H. Minchin, S. Jahnke, J.T. van Dongen, U. Schittko, and I.T. Baldwin. 2006. SNF1-related kinases allow plants to tolerate herbivory by allocating carbon to roots. *Proceedings of the National Academy of Sciences, USA* 103:12935–12940.
- Schweitzer, J.A., J.K. Bailey, B.J. Rehill, G.D. Martinsen, S.C. Hart, R.L. Lindroth, P. Keim, and T.G. Whitham. 2004. Genetically based trait in a dominant tree affects ecosystem processes. *Ecology Letters* 7:127–134.
- Schweitzer, J.A., J.K. Bailey, S.C. Hart, G.M. Wimp, S.K. Chapman, and T.G. Whitham. 2005. The interaction of plant genotype and herbivory decelerate leaf litter decomposition and alter nutrient dynamics. *Oikos* 110:133–145.
- Scott, A.C., and T.N. Taylor. 1983. Plant/animal interactions during the Upper Carboniferous. *The Botanical Review* 49:259–307.
- Scriber, J.M., and F. Slansky, Jr. 1981. The nutritional ecology of immature insects. *Annual Review of Entomology* 26:183–211.
- Sears, M.K., R.L. Hellmich, D.E. Stanley-Horn, K.S. Oberhauser, J.M. Pleasants, H.R. Mattila, B.D. Siegfried, and G.P. Dively. 2001. Impact of *Bt* corn pollen on monarch butterfly populations: a risk assessment. *Proceedings of the National Academy of Sciences, USA* 98:11937–11942.
- Seastedt, T.R. 1984. The role of microarthropods in decomposition and mineralization processes. *Annual Review of Entomology* 29:25–46.
- Seastedt, T.R. 1985. Maximization of primary and secondary productivity by grazers. *American Naturalist* 126:559–564.
- Seastedt, T.R. 2000. Soil fauna and controls of carbon dynamics: comparisons of rangelands and forests across latitudinal gradients. In *Invertebrates as Webmasters in Ecosystems* (D.C. Coleman, and P. Hendrix, Eds.), pp. 99–114. CAB International, Wallingford, UK.
- Seastedt, T.R., and D.A. Crossley, Jr. 1981a. Microarthropod response following cable logging and clear-cutting in the southern Appalachians. *Ecology* 62:126–135.
- Seastedt, T.R., and D.A. Crossley, Jr. 1981b. Sodium dynamics in forest ecosystems and the animal starvation hypothesis. *American Naturalist* 117:1029–1034.
- Seastedt, T.R., and D.A. Crossley, Jr. 1983. Nutrients in forest litter treated with naphthalene and simulated throughfall: a field microcosm study. *Soil Biology and Biochemistry* 15:159–165.
- Seastedt, T.R., and D.A. Crossley, Jr. 1984. The influence of arthropods on ecosystems. *BioScience* 34:157–161.

- Seastedt, T.R., and C.M. Tate. 1981. Decomposition rates and nutrient contents of arthropod remains in forest litter. *Ecology* 62:13–19.
- Seastedt, T.R., D.A. Crossley, Jr., and W.W. Hargrove. 1983. The effects of low-level consumption by canopy arthropods on the growth and nutrient dynamics of black locust and red maple trees in the southern Appalachians. *Ecology* 64:1040–1048.
- Seastedt, T.R., R.A. Ramundo, and D.C. Hayes. 1988. Maximization of densities of soil animals by foliage herbivory: empirical evidence, graphical and conceptual models. *Oikos* 51:243–248.
- Seastedt, T.R., M.V. Reddy, and S.P. Cline. 1989. Microarthropods in decomposing wood from temperate coniferous and deciduous forests. *Pedobiologia* 33:69–78.
- Segraves, K.A. 2008. Florivores limit cost of mutualism in the yucca–yucca moth association. *Ecology* 89:3215–3221.
- Şekerciöğlu, Ç.H., P.R. Ehrlich, G.C. Daily, D. Aygen, D. Goehring, and R.F. Sandi. 2002. Disappearance of insectivorous birds from tropical forest fragments. *Proceedings of the National Academy of Sciences, USA* 99:263–267.
- Senthil-Nathan, S., K. Kalaivani, M.-Y. Choi, and C.-H. Paik. 2009. Effects of jasmonic acid-induced resistance in rice on the plant brownhopper, *Nilaparvata lugens* Stål (Homoptera: Delphacidae). *Pesticide Biochemistry and Physiology* 95:77–84.
- Setälä, H., and V. Huhta. 1991. Soil fauna increase *Betula pendula* growth: laboratory experiments with coniferous forest floor. *Ecology* 72:665–671.
- Setälä, H., V.G. Marshall, and J.A. Trofymow. 1996. Influence of body size of soil fauna on litter decomposition and <sup>15</sup>N uptake by poplar in a pot trial. *Soil Biology and Biochemistry* 28:1661–1675.
- Sexton, J.M., and T.D. Schowalter. 1991. Physical barriers to reduce *Lepesoma lecontei* (Coleoptera: Curculionidae) damage to conelets in a Douglas-fir seed orchard in western Oregon. *Journal of Economic Entomology* 84:212–214.
- Seymour, A.S., D. Gutiérrez, and D. Jordano. 2003. Dispersal of the lycaenid *Plebejus argus* in response to patches of its mutualist ant *Lasius niger*. *Oikos* 103:162–174.
- Sharkey, M.J. 2001. The all taxa biological inventory of the Great Smoky Mountains National Park. *Florida Entomologist* 84:556–564.
- Shaw, III, C.G., and B.B. Eav. 1993. Modeling interactions. In *Beetle–pathogen Interactions in Conifer Forests* (T.D. Schowalter, and G.M. Filip, Eds.), pp. 199–208. Academic Press, London, UK.
- Shaw, D.C. 1998. Distribution of larval colonies of *Lophocampa argentata* Packard, the silver spotted tiger moth (Lepidoptera: Arctiidae), in an old growth Douglas-fir/western hemlock forest canopy, Cascade Mountains, Washington State, USA. *Canadian Field Naturalist* 112:250–253.
- Shaw, D.C. 2004. Vertical organization of canopy biota. In *Forest Canopies* (M.D. Lowman, and H.B. Rinker, Eds.), pp. 73–101. Elsevier/Academic Press, Amsterdam, The Netherlands.
- Shaw, P.B., D.B. Richman, J.C. Owens, and E.W. Huddleston. 1987. Ecology of the range caterpillar, *Hemileuca oliviae* Cockerell. In *Integrated Pest Management on Rangeland: a Shortgrass Prairie Perspective* (J.L. Capinera, Ed.), pp. 234–247. Westview Press, Boulder, CO.
- Shea, S.R., M. McCormick, and C.C. Portlock. 1979. The effect of fires on regeneration of leguminous species in the northern jarrah (*Eucalyptus marginata* Sm) forest of Western Australia. *Australian Journal of Ecology* 4:195–205.
- Shelford, V.E. 1907. Preliminary note on the distribution of the tiger beetle (*Cicindela*) and its relation to plant succession. *Biological Bulletin* 14:9–14.
- Shelford, V.E. 1918. Physiological problems in the life-histories of animals with particular reference to their seasonal appearance. *American Naturalist* 52:129–154.
- Shelton, T.G., and J.K. Grace. 2003. Effects of exposure duration on transfer of nonrepellent termiticides among workers of *Coptotermes formosanus* Shiraki (Isoptera: Rhinotermitidae). *Journal of Economic Entomology* 96:456–460.
- Sheppard, P.M., J.R.G. Turner, K.S. Brown, W.W. Benson, and M.C. Singer. 1985. Genetics and the evolution of Müllertian mimicry in *Heliconius* butterflies. *Philosophical Transactions of the Royal Society of London B Biological Sciences* 308:433–613.
- Sheppard, S., and P. Picard. 2006. Visual-quality impact of forest pest activity at the landscape level: a synthesis of published knowledge and research needs. *Landscape and Urban Planning* 77:321–342.
- Sherman, R.A., M.J.R. Hall, and S. Thomas. 2000. Medical maggots: an ancient remedy for some contemporary afflictions. *Annual Review of Entomology* 45:55–81.
- Sherman, R.A., H. Stevens, D. Ng, and E. Iversen. 2007. Treating wounds in small animals with maggot debridement therapy: a survey of practitioners. *Veterinary Journal* 173:138–143.
- Sherratt, T.N., and P.C. Jepson. 1993. A metapopulation approach to modelling the long-term impact of pesticides on invertebrates. *Journal of Applied Ecology* 30:696–705.
- Shettleworth, S.J. 1984. Learning and behavioural ecology. In *Behavioural Ecology: an Evolutionary Approach* (J.R. Krebs, and N.B. Davies, Eds.), pp. 170–194. Blackwell Scientific, Oxford, UK.
- Shonle, I., and J. Bergelson. 2000. Evolutionary ecology of the tropane alkaloids of *Datura stramonium* L. (Solanaceae). *Evolution* 54:778–788.
- Showalter, A.M., S. Heuberger, B.E. Tabashnik, and Y. Carrière. 2009. A primer for using transgenic

- insecticidal cotton in developing countries. *Journal of Insect Science* 9:22–39.
- Showler, A.T. 2009. Roles of host plants in boll weevil range expansion beyond tropical Mesoamerica. *American Entomologist* 55:234–242.
- Shugart, H.H., D.C. West, and W.R. Emanuel. 1981. Patterns and dynamics of forests: an application of simulation models. In *Forest Succession: Concepts and Application* (D.C. West, H.H. Shugart, and D.B. Botkin, Eds.), pp. 74–94. Springer-Verlag, New York, NY.
- Shure, D.J., and D.L. Phillips. 1991. Patch size of forest openings and arthropod populations. *Oecologia* 86:325–334.
- Shure, D.J., and L.A. Wilson. 1993. Patch-size effects on plant phenolics in successional openings of the southern Appalachians. *Ecology* 74:55–67.
- Shurin, J.B., E.T. Borer, E.W. Seabloom, K. Anderson, C.A. Blanchette, B. Broitman, S.D. Cooper, and B.S. Halpern. 2002. A cross-ecosystem comparison of the strength of trophic cascades. *Ecology Letters* 5:785–791.
- Shuster, S.M., E.V. Lonsdorf, G.M. Wimp, J.K. Bailey, and T.G. Whitham. 2006. Community heritability measures the evolutionary consequences of indirect genetic effects on community structure. *Evolution* 60:991–1003.
- Siemann, E. 1998. Experimental tests of effects of plant productivity and diversity on grassland arthropod diversity. *Ecology* 79:2057–2070.
- Siepel, H., and E.M. de Ruiter-Dijkman. 1993. Feeding guilds of oribatid mites based on their carbohydrazase activities. *Soil Biology and Biochemistry* 25:1491–1497.
- Siepielski, A.M., K.-L. Hung, E.E.B. Bein, and M.A. McPeck. 2010. Experimental evidence for neutral community dynamics governing an insect assemblage. *Ecology* 91:847–857.
- Sillén-Tullberg, B. 1985. Higher survival of an aposomatic than of a cryptic form of a distasteful bug. *Oecologia* 67:411–415.
- Silva, S.I., W.P. MacKay, and W.G. Whitford. 1985. The relative contributions of termites and microarthropods to fluff grass litter disappearance in the Chihuahuan Desert. *Oecologia* 67:31–34.
- Simard, M., and S. Payette. 2005. Reduction of black spruce seed bank by spruce budworm infestation compromises postfire stand regeneration. *Canadian Journal of Forest Research* 35:1686–1696.
- Simberloff, D.S. 1969. Experimental zoology of islands: a model for insular colonization. *Ecology* 50:296–314.
- Simberloff, D.S. 1974. Equilibrium theory of island biogeography and ecology. *Annual Review of Ecology and Systematics* 5:161–182.
- Simberloff, D.S. 1978. Colonization of islands by insects: immigration, extinction, and diversity. In *Diversity of Insect Faunas. Symposium of the Royal Entomological Society, London No. 9* (L.A. Mound, and N. Waloff, Eds.), pp. 139–153. Royal Entomological Society, London, UK.
- Simberloff, D.S., and T. Dayan. 1991. The guild concept and the structure of ecological communities. *Annual Review of Ecology and Systematics* 22:115–143.
- Simberloff, D.S., and E.O. Wilson. 1969. Experimental zoogeography of islands: the colonization of empty islands. *Ecology* 50:278–295.
- Similä, M., J. Kouki, P. Martikainen, and A. Uotila. 2002. Conservation of beetles in boreal pine forests: the effects of forest age and naturalness on species assemblages. *Biological Conservation* 106:19–27.
- Simpson, S.J., and D. Raubenheimer. 1993. A multi-level analysis of feeding behaviour: the geometry of nutritional decisions. *Philosophical Transactions of the Royal Society of London, Series B* 342:381–402.
- Simpson, S.J., D. Raubenheimer, S.T. Behmer, A. Whitworth, and G.A. Wright. 2002. A comparison of nutritional regulation in solitary and gregarious phase nymphs of the desert locust *Schistocerca gregaria*. *Journal of Experimental Biology* 205:121–129.
- Sims, P.L., and J.S. Singh. 1978. The structure and function of ten western North American grasslands. III. Net primary production, turnover and efficiencies of energy capture and water use. *Journal of Ecology* 66:573–597.
- Sinclair, A.R.E. 1975. The resource limitation of trophic levels in tropical grassland ecosystems. *Journal of Animal Ecology* 44:497–520.
- Sinclair, B.J., M.R. Worland, and D.A. Wharton. 1999. Ice nucleation and freezing tolerance in New Zealand alpine and lowland weta, *Hemideina* spp. (Orthoptera; Stenopelmatidae). *Physiological Entomology* 24:56–63.
- Sinclair, B.J., P. Vernon, C.J. Klok, and S.L. Chown. 2003. Insects at low temperatures: an ecological perspective. *Trends in Ecology and Evolution* 18:257–262.
- Singh, G., and S. Prakash. 2009. Efficacy of *Bacillus sphaericus* against larvae of malaria and filarial vectors: an analysis of early resistance detection. *Parasitology Research* 104:763–766.
- Skarmoutsos, G., and C. Millar. 1982. *Adelges* aphids and fungi causing premature defoliation of larch. *European Journal of Forest Pathology* 12:73–78.
- Skellam, J.G. 1951. Random dispersal in theoretical populations. *Biometrika* 38:196–218.
- Skovmand, O., T.D.A. Ouedraogo, E. Sanogo, H. Samuelson, L.P. Toé, and T. Baldet. 2009. Impact of slow-release *Bacillus sphaericus* granules on mosquito populations followed in a tropical urban environment. *Journal of Medical Entomology* 46:67–76.
- Slansky, F. Jr., 1978. Utilization of energy and nitrogen by larvae of the imported cabbageworm, *Pieris rapae*, as affected by parasitism by *Apanteles glomeratus*. *Environmental Entomology* 7:179–185.

- Smalley, A.E. 1960. Energy flow of a salt marsh grasshopper population. *Ecology* 41:672–677.
- Smedley, S.R., and T. Eisner. 1995. Sodium uptake by puddling in a moth. *Science* 270:1816–1818.
- Smith, A.A., B. Hölldobler, and J. Liebig. 2009. Cyclic hydrocarbons reliably identify cheaters and allow enforcement of altruism in social insects. *Current Biology* 19:78–81.
- Smith, B.H., and M.D. Breed. 1995. The chemical basis for nestmate recognition and mate discrimination in social insects. In *Chemical Ecology of Insects* 2 (R.T. Cardé, and W.J. Bell, Eds.), pp. 287–317. Chapman & Hall, New York, NY.
- Smith, C.M. 2005. Plant Resistance to Arthropods: Molecular and Conventional Approaches. Springer, Dordrecht, The Netherlands.
- Smith, F.R., and R.I. Yeaton. 1998. Disturbance by the mound-building termite, *Trinervitermes trinervoides*, and vegetation patch dynamics in a semi-arid, southern African grassland. *Plant Ecology* 137:41–53.
- Smith, J.M. 1964. Group selection and kin selection. *Nature* 201:1145–1147.
- Smith, J.M.B. 1989. An example of ant-assisted plant invasion. *Australian Journal of Ecology* 14:247–250.
- Smith, J.P., and T.D. Schowalter. 2001. Aphid-induced reduction of shoot and root growth in Douglas-fir seedlings. *Ecological Entomology* 26:411–416.
- Smith, K.F., D.F. Sax, S.D. Gaines, V. Guernier, and J.-F. Guégan. 2007. Globalization of human infectious disease. *Ecology* 88:1903–1910.
- Smith, K.G.V. 1986. A Manual of Forensic Entomology. Cornell University Press, Ithaca, NY.
- Smith, M.T., P.C. Tabin, J. Bancroft, G. Li, and R. Gao. 2004. Dispersal and spatiotemporal dynamics of Asian longhorned beetle (Coleoptera: Cerambycidae) in China. *Environmental Entomology* 33:435–442.
- Smith, R.C. 1954. An analysis of 100 years of grasshopper populations in Kansas (1854 to 1954). *Transactions of the Kansas Academy of Science* 57:397–433.
- Smith, R.H. 2007. History of the Boll Weevil in Alabama. Alabama Agricultural Experiment Station Bulletin 670, Auburn, AL.
- Smith, S., T.E. Reagan, J.L. Flynn, and G.H. Willis. 1983. Azinphosmethyl and fenvalerate runoff loss from a sugarcane-insect IPM system. *Journal of Environmental Quality* 12:534–537.
- Smith, W.H. 1981. Air Pollution and Forests: Interactions Between Air Contaminants and Forest Ecosystems. Springer-Verlag, New York, NY.
- Soderlund, D.M., and J.R. Bloomquist. 1990. Molecular mechanisms of insecticide resistance. In *Pesticide Resistance in Arthropods* (R.T. Roush, and B.E. Tabashnik, Eds.), pp. 58–96. Chapman & Hall, New York, NY.
- Sollins, P., S.P. Cline, R. Verhoeven, D. Sachs, and G. Spycher. 1987. Patterns of log decay in old-growth Douglas-fir forests. *Canadian Journal of Forest Research* 17:1585–1595.
- Solomon, A.M., D.C. West, and J.A. Solomon. 1981. Simulating the role of climate change and species immigration in forest succession. In *Forest Succession: Concepts and Application* (D.C. West, H.H. Shugart, and D.B. Botkin, Eds.), pp. 154–177. Springer-Verlag, New York, NY.
- Somanathan, H., R.M. Borges, and V.S. Chakravarthy. 2004. Does neighbourhood floral display matter? Fruit set in carpenter bee-pollinated *Heterophragma quadriloculare* and beetle-pollinated *Lasiosiphon eriocephalus*. *Biotropica* 36:139–147.
- Somlyódy, L., and G., van Straten (Eds.) 1986. *Modeling and Managing Shallow Lake Eutrophication, with Application to Lake Balaton*. Springer-Verlag, Berlin, Germany.
- Song, M.Y., and J.J. Brown. 2006. Influence of fluctuating salinity on insecticide tolerance of two euryhaline arthropods. *Journal of Economic Entomology* 99:745–751.
- Sopow, S.L., J.D. Shorthouse, W. Strong, and D.T. Quiring. 2003. Evidence for long-distance, chemical gall induction by an insect. *Ecology Letters* 6:102–105.
- Sorensen, B.C., E.H. Smith, J. Smith, and Y. Carton. 2008. Charles V. Riley, France, and *Phylloxera*. *American Entomologist* 54:134–149.
- Soulé, M.E., and D. Simberloff. 1986. What do genetics and ecology tell us about the design of nature refuges? *Biological Conservation* 35:19–40.
- Sousa, W.P. 1979. Disturbance in marine intertidal boulder fields: the nonequilibrium maintenance of species diversity. *Ecology* 60:1225–1239.
- Sousa, W.P. 1985. Disturbance and patch dynamics on rocky intertidal shores. In *Ecology of Natural Disturbance and Patch Dynamics* (S.T.A. Pickett, and P.S. White, Eds.), pp. 101–124. Academic Press, New York, NY.
- Sousa, W.P., S.P. Quek, and B.J. Mitchell. 2003. Regeneration of *Rhizophora mangle* in a Caribbean mangrove forest: interacting effects of canopy disturbance and a stem-boring beetle. *Oecologia* 137:436–445.
- Southwick, L.M., G.H. Willis, T.E. Reagan, and L.M. Rodriguez. 1995. Residues in runoff and on leaves of azinphosmethyl and fenvalerate applied to sugarcane. *Environmental Entomology* 24:1013–1017.
- Southwood, T.R.E. 1975. The dynamics of insect populations. In *Insects, Science, and Society* (D. Pimentel, Ed.), pp. 151–199. Academic Press, San Diego, CA.
- Southwood, T.R.E. 1977. The relevance of population dynamics theory to pest status. In *Origins of Pest, Parasite, Disease and Weed Problems. Symposium of the British Ecological Society* 18 (J.M. Cherrett, and G.R. Sagar, Eds.), pp. 35–54. British Ecological Society, London, UK.



- Southwood, T.R.E. 1978. *Ecological Methods with Particular Reference to the Study of Insect Populations*. Methuen, Inc., London, UK.
- Spaethe, J., J. Tautz, and L. Chittka. 2001. Visual constraints in foraging bumblebees: flower size and color affect search time and flight behavior. *Proceedings of the National Academy of Sciences, USA* 98:3898–3903.
- Spain, A.V., and R.P. Le Feuvre. 1987. Breakdown of four litters of contrasting quality in a tropical Australian rain forest. *Journal of Applied Ecology* 24:279–288.
- Spain, A.V., and R.P. Le Feuvre. 1997. Stable C and N isotope values of selected components of a tropical Australian sugarcane ecosystem. *Biology and Fertility of Soils* 24:118–222.
- Speer, J.H., T.W. Swetnam, B.E. Wickman, and A. Youngblood. 2001. Changes in Pandora moth outbreak dynamics during the past 622 years. *Ecology* 82:679–697.
- Spehn, E.M., A. Hector, J. Joshi, M. Scherer-Lorenzen, B. Schmid, E. Bazeley-White, C. Beierkuhnlein, M.C. Caldeira, M. Diemer, P.G. Dimitrakopoulos, J.A. Finn, H. Freitas, P.S. Giller, J. Good, R. Harris, P. Höglberg, K. Huss-Danell, A. Jumpponen, J. Koricheva, P.W. Leadley, M. Loreau, A. Minns, C.P.H. Mulder, G. O'Donovan, S.J. Otway, C. Palmberg, J.S. Pereira, A.B. Pfisterer, A. Prinz, D.J. Read, E.-D. Schultze, A.-S.D. Siamantziouras, A.C. Terry, A.Y. Troumbis, F.I. Woodward, S. Yachi, and J.H. Lawton. 2005. Ecosystem effects of biodiversity manipulations in European grasslands. *Ecological Monographs* 75:37–63.
- Spencer, H.J., and G.R. Port. 1988. Effects of roadside conditions on plants and insects. II. Soil conditions. *Journal of Applied Ecology* 25:709–715.
- Spencer, H.J., N.E. Scott, G.R. Port, and A.W. Davison. 1988. Effects of roadside conditions on plants and insects. I. atmospheric conditions. *Journal of Applied Ecology* 25:699–707.
- Springett, B.P. 1968. Aspects of the relationship between burying beetles, *Necrophorus* spp. and the mite, *Poecilochirus necrophori* Vitz. *Journal of Animal Ecology* 37:417–424.
- Srinivasan, M.V., S. Zhang, M. Alwein, and J. Tautz. 2000. Honeybee navigation: nature and calibration of the “odometer”. *Science* 287:851–853.
- Stach, S., J. Benard, and M. Giurfa. 2004. Local-feature assembling in visual pattern recognition and generalization in honeybees. *Nature* 429:758–761.
- Stachurski, A., and J.R. Zimka. 1984. The budget of nitrogen dissolved in rainfall during its passing through the crown canopy in forest ecosystems. *Ekologia Polska* 32:191–218.
- Stadler, B., and T. Müller. 1996. Aphid honeydew and its effect on the phyllosphere microflora of *Picea abies* (L.) Karst. *Oecologia* 108:771–776.
- Stadler, B., B. Michalzik, and T. Müller. 1998. Linking aphid ecology with nutrient fluxes in a coniferous forest. *Ecology* 79:1514–1525.
- Stadler, B., S. Solinger, and B. Michalzik. 2001. Insect herbivores and the nutrient flow from the canopy to the soil in coniferous and deciduous forests. *Oecologia* 126:104–113.
- Stadler, B., T. Müller, and D. Orwig. 2006. The ecology of energy and nutrient fluxes in hemlock forests invaded by hemlock woolly adelgid. *Ecology* 87:1792–1804.
- Städler, E. 1984. Perceptual mechanisms. In *Chemical Ecology of Insects* (W.J. Bell, and R.T. Cardé, Eds.), pp. 3–35. Chapman and Hall, London, UK.
- Stamp, N.E. 1992. Relative susceptibility to predation of two species of caterpillars on plantain. *Oecologia* 92:124–129.
- Stamp, N. 2004. Can the growth-differentiation balance hypothesis be tested rigorously? *Oikos* 107:439–448.
- Stamp, N.E., and M.D. Bowers. 1990. Variation in food quality and temperature constrain foraging of gregarious caterpillars. *Ecology* 71:1031–1039.
- Stamp, N.E., Y. Yang, and T.L. Osier. 1997. Response of an insect predator to prey fed multiple allelochemicals under representative thermal regimes. *Ecology* 78:203–214.
- Stanko-Golden, K.M., W.T. Swank, and J.W. Fitzgerald. 1994. Factors affecting sulfate adsorption, organic sulfur formation, and mobilization in forest and grassland spodosols. *Biology and Fertility of Soils* 17:289–296.
- Stanton, M.L. 1983. Spatial patterns in the plant community and their effects upon insect search. In *Herbivorous Insects: Host-seeking Behavior and Mechanisms* (S. Ahmad, Ed.), pp. 125–157. Academic Press, New York, NY.
- Stanton, N. 1975. Herbivore pressure on 2 types of forests. *Biotropica* 7:8–11.
- Stapp, P., M.F. Antolin, and M. Ball. 2004. Patterns of extinction in prairie dog metapopulations: plague outbreaks follow El Niño events. *Frontiers in Ecology and the Environment* 2:235–240.
- Starzyk, J.R., and Z. Witkowski. 1981. Changes in the parameters describing the cambio- and xylophagous insect communities during the secondary succession of the oak-hornbeam association in the Niepolomice Forest near Kraków. *Zeitschrift für angewandte Entomologie* 91:525–533.
- Steelman, C.D. 1976. Effects of external and internal arthropod parasites on domestic livestock production. *Annual Review of Entomology* 21:155–178.
- Steffan-Dewenter, I., and T. Tscharnke. 1999. Effects of habitat isolation on pollinator communities and seed set. *Oecologia* 121:432–440.
- Steffan-Dewenter, I., U. Münzenberg, and T. Tscharnke. 2001. Pollination, seed set and seed predation on a landscape scale. *Proceedings of the Royal Society of London B* 268:1685–1690.
- Steffan-Dewenter, I., U. Münzenberg, C. Bürger, C. Thies, and T. Tscharnke. 2002. Scale-dependent

- effects of landscape context on three pollinator guilds. *Ecology* 83:1421–1432.
- Steidle, J.L.M. 1998. Learning pays off: influence of experience on host finding and parasitism in *Lar-iophagus distinguendus*. *Ecological Entomology* 23:451–456.
- Stephen, F.M., C.W. Berisford, D.L. Dahlsten, P. Fenn, and J.C. Moser. 1993. Invertebrate and microbial associates. In *Beetle-pathogen Interaction in Conifer Forests* (T.D. Schowalter, and G.M. Filip, Eds.), pp. 129–153. Academic Press, London, UK.
- Stephens, D.W., and J.R. Krebs. 1986. Foraging theory. Princeton University Press, Princeton, NJ.
- Stermitz, F.R., J.N. Tawara, M. Boeckl, M. Pomeroy, T.A. Foderaro, and F.G. Todd. 1994. Piperidine alkaloid content of *Picea* (spruce) and *Pinus* (pine). *Phytochemistry* 35:951–953.
- Stern, V.M., R.F. Smith, R. van den Bosch, and K.S. Hagen. 1959. The integration of chemical and biological control of the spotted alfalfa aphid. Part 1. The integrated control concept. *Hilgardia* 29:81–101.
- Sterner, R.W., and J.J. Elser. 2002. Ecological Stoichiometry: the Biology of Elements from Molecules to the Biosphere. Princeton University Press, Princeton, NJ.
- Stevens, M.T., D.M. Waller, and R.L. Lindroth. 2007. Resistance and tolerance in *Populus tremuloides*: genetic variation, costs, and environmental dependency. *Evolutionary Ecology* 21:829–847.
- Stewart, M.M., and L.L. Woolbright. 1996. Amphibians. In *The Food Web of a Tropical Rain Forest* (D.P. Reagan, and R.B. Waide, Eds.), pp. 273–320. University of Chicago Press, Chicago, IL.
- Sticher, L., B. Mauch-Mani, and M.P. Métraux. 1997. Systematic acquired resistance. *Annual Review of Phytopathology* 35:235–270.
- Stige, L.C., K.-S. Chan, Z. Zhang, D. Frank, and N.C. Stenseth. 2007. Thousand-year-long Chinese time series reveals climatic forcing of decadal locust dynamics. *Proceedings of the National Academy of Sciences, USA* 104:16188–16193.
- Stiles, J.H., and R.H. Jones. 1998. Distribution of the red imported fire ant, *Solenopsis invicta*, in road and powerline habitats. *Landscape Ecology* 13:335–346.
- Stiling, P.D. 1996. Ecology: Theories and Applications. Prentice-Hall, Upper Saddle River, NJ.
- Stiling, P., and D.C. Moon. 2005. Quality or quantity: the direct and indirect effects of host plants on herbivores and their natural enemies. *Oecologia* 142:413–420.
- Stiling, P.D., D. Simberloff, and B.V. Brodbeck. 1991. Variation in rates of leaf abscission between plants may affect the distribution patterns of sessile insects. *Oecologia* 88:367–370.
- Stone, J.E., T.E. Kolb, and W.W. Covington. 1999. Effects of restoration thinning on presettlement *Pinus ponderosa* in northern Arizona. *Restoration Ecology* 7:172–182.
- Stone, M.K., and J.B. Wallace. 1998. Long-term recovery of a mountain stream from clear-cut logging: the effects of forest succession on benthic invertebrate community structure. *Freshwater Biology* 39:151–169.
- Storey, A.W., and L.C.V. Pinder. 1985. Mesh-size and efficiency of sampling larval Chironomidae. *Hydrobiologia* 124:193–197.
- Stork, N.E. 1987. Guild structure of arthropods from Bornean rain forest trees. *Ecological Entomology* 12:69–80.
- Stout, J., and J. Vandermeer. 1975. Comparison of species richness for stream-inhabiting insects in tropical and mid-latitude streams. *American Naturalist* 109:263–280.
- Stout, M.J., and R.M. Bostock. 1999. Specificity of induced responses to arthropods and pathogens. In *Induced Plant Defenses Against Pathogens and Herbivores: Biochemistry, Ecology, and Agriculture* (A.A. Agrawal, S. Tuzun, and E. Bent, Eds.), pp. 183–209. American Phytopathological Society, St. Paul, MN.
- Stout, M.J., G.W. Zehnder, and M.E. Baur. 2002. Potential for use of elicitors of plant resistance in arthropod management programs. *Archives of Insect Biochemistry and Physiology* 51:222–235.
- Stout, M.J., J.S. Thaler, and B.P.H.J. Thomma. 2006. Plant-mediated interactions between pathogenic microorganisms and herbivorous insects. *Annual Review of Entomology* 51:663–689.
- Stout, R.J. 1989. Effects of condensed tannins on leaf processing in mid-latitude and tropical streams: a theoretical approach. *Canadian Journal of Fisheries and Aquatic Sciences* 46:1097–1106.
- Straub, C.S., and W.E. Snyder. 2008. Increasing enemy biodiversity strengthens herbivore suppression on two plant species. *Ecology* 89:1605–1615.
- Strauss, S.Y., and P. Murch. 2004. Towards an understanding of the mechanisms of tolerance: compensating for herbivore damage by enhancing a mutualism. *Ecological Entomology* 29:234–239.
- Strauss, S.Y., R.E. Irwin, and V.M. Lambrix. 2004. Optimal defence theory and flower petal colour predict variation in the secondary chemistry of wild radish. *Journal of Ecology* 92:132–141.
- Streams, F.A. 1994. Effect of prey size on attack components of the functional response by *Notonecta undulata*. *Oecologia* 98:57–63.
- Strickland, T.C., and J.W. Fitzgerald. 1986. Organosulphur recalcitrance in soil and litter from a hardwood forest. *Soil Biology and Biochemistry* 18:661–662.
- Strom, B.L., L.M. Roton, R.A. Goyer, and J.R. Meeker. 1999. Visual and semiochemical disruption of host finding in the southern pine beetle. *Ecological Applications* 9:1028–1038.
- Strong, D.R. 1992. Are trophic cascades all wet? Differentiation and donor-control in speciose ecosystems. *Ecology* 73:747–754.

- Strong, D.R., J.H. Lawton, and T.R.E. Southwood. 1984. *Insects on Plants: Community Patterns and Mechanisms*. Harvard University Press, Cambridge, MA.
- Strong, D.R., J.L. Maron, P.G. Connors, A. Whipple, S. Harrison, and R.L. Jeffries. 1995. High mortality, fluctuation in numbers, and heavy subterranean insect herbivory in bush lupine, *Lupinus arboreus*. *Oecologia* 104:85–92.
- Strong, W.B., B.A. Croft, and D.H. Slone. 1997. Spatial aggregation and refugia of the mites *Tetranychus urticae* and *Neoseiulus fallacis* (Acari: Tetranychidae, Phytoseiidae) on hop. *Environmental Entomology* 26:859–865.
- Sturgeon, K.B., and J.B. Mitton. 1986. Allozyme and morphological differentiation of mountain pine beetles *Dendroctonus ponderosae* Hopkins (Coleoptera: Scolytidae) associated with host trees. *Evolution* 40:290–302.
- Suarez, A.V., D.T. Bolger, and T.J. Case. 1998. Effects of fragmentation and invasion on native ant communities in coastal southern California. *Ecology* 79:2041–2056.
- Suarez, A.V., D.A. Holway, and T.J. Case. 2001. Patterns of spread in biological invasions dominated by long-distance jump dispersal: insights from Argentine ants. *Proceedings of the National Academy of Sciences, USA* 98:1095–1100.
- Suarez, M.E., and B.L. Thorne. 2000. Rate, amount, and distribution pattern of alimentary fluid transfer via trophallaxis in three species of termites (Isoptera: Rhinotermitidae). *Annals of the Entomological Society of America* 93:145–155.
- Summerville, K.S., and T.O. Crist. 2001. Effects of experimental habitat fragmentation on patch use by butterflies and skippers (Lepidoptera). *Ecology* 82:1360–1370.
- Summerville, K.S., and T.O. Crist. 2004. Contrasting effects of habitat quantity and quality on moth communities in fragmented landscapes. *Ecography* 27:3–12.
- Summerville, K.S., J.A. Veech, and T.O. Crist. 2002. Does variation in patch use among butterfly species contribute to nestedness at fine spatial scales?. *Oikos* 97:195–204.
- Swank, W.T., J.B. Waide, D.A. Crossley, Jr., and R.L. Todd. 1981. Insect defoliation enhances nitrate export from forest ecosystems. *Oecologia* 51:297–299.
- Swenson, N.G., D.L. Mahler, M. Ferro, and A. Ritchie. 2007. The energetic determination, spatial dispersion and density dependence of Mymeleon ant lion pits in Las Cruces, Cost Rica. *Biotropica* 39:774–777.
- Swetnam, T.W., and A.M. Lynch. 1989. A tree-ring reconstruction of western spruce budworm history in the southern Rocky Mountains. *Forest Science* 35:962–986.
- Swetnam, T.W., and A.M. Lynch. 1993. Multicentury, regional-scale patterns of western spruce budworm outbreaks. *Ecological Monographs* 63:399–424.
- Swift, M.J. 1977. The ecology of wood decomposition. *Science Progress (Oxford)* 64:175–199.
- Swift, M.J., O.W. Heal, and J.M. Anderson. 1979. *Decomposition in Terrestrial Ecosystems*. Blackwell Scientific, Oxford, UK.
- Sword, M.A. 1998. Seasonal development of loblolly pine lateral roots in response to stand density and fertilization. *Plant and Soil* 200:21–25.
- Symondson, W.O.C., K.D. Sunderland, and M.H. Greenstone. 2002. Can generalist predators be effective biocontrol agents? *Annual Review of Entomology* 47:561–594.
- Szujko-Lacza, J. 1982. The Flora of the Hortobágy National Park. Akadémiai Kiadó, Budapest, Hungary.
- Szujko-Lacza, J., and D. Kovacs (Eds.) 1993. The Flora of the Kiskunság National Park. Akadémiai Kiadó, Budapest, Hungary.
- Tabashnik, B.E. 1994. Evolution of resistance to *Bacillus thuringiensis*. *Annual Review of Entomology* 39:47–79.
- Tabashnik, B.E., F.R. Groeters, N. Finson, Y.B. Liu, M.W. Johnson, D.G. Heckel, K. Luo and M.L. Adang. 1996. Resistance to *Bacillus thuringiensis* in *Plutella xylostella*: the moth heard round the world. In *Molecular Genetics and Evolution of Pesticide Resistance, American Chemical Society Symposium Series 645*, pp. 130–140. Washington, DC.
- Tabashnik, B.E., N. Finson, F.R. Groeters, W.J. Moarr, M.W. Johusm, K. Luo, and M.J. Adang. 1994. Reversal of resistance to *Bacillus thuringiensis* in *Plutella xylostella*. *Proceeding of the National Academy of Sciences, USA* 91: 4120–4124.
- Tabashnik, B.E., Y.B. Liu, N. Finson, L. Masson, and D.G. Heckel. 1997. One gene in diamondback moth confers resistance to four *Bacillus thuringiensis* toxins. *Proceedings of the National Academy of Sciences, USA* 94:1640–1644.
- Tabashnik, B.E., A.J. Gassmann, D.W. Crowder, and Y. Carrière. 2008. Insect resistance to Bt crops: evidence vs. theory. *Nature Biotechnology* 26:199–202.
- Tack, A.J.M., O. Ovsskainen, P.J. Harrison, and T. Roslin. 2009. Competition as a structuring force in leaf miner communities. *Oikos* 118:809–818.
- Tahvanainen, J.O., and R.B. Root. 1972. The influence of vegetational diversity on the population ecology of a specialized herbivore, *Phyllotreta cruciferae* (Coleoptera: Chrysomelidae). *Oecologia* 10:321–346.
- Taki, H., P.G. Kevan, and J.S. Ascher. 2007. Landscape effects of forest loss in a pollination system. *Landscape Ecology* 22:1575–1587.
- Tallamy, D.W., and F.T. Halaweish. 1993. Effects of age, reproductive activity, sex, and prior exposure on sensitivity to cucurbitacins in southern corn rootworm (Coleoptera: Chrysomelidae). *Environmental Entomology* 22:922–925.

- Tallamy, D.W., J. Stull, N.P. Ehresman, P.M. Gorski, and C.E. Mason. 1997. Cucurbitacins as feeding and oviposition deterrents to insects. *Environmental Entomology* 26:678–683.
- Tallamy, D.W., D.P. Whittington, F. Defurio, D.A. Fontaine, P.M. Gorski, and P.W. Gothro. 1998. Sequestered cucurbitacins and pathogenicity of *Metarhizium anisopliae* (Moniliales: Moniliaceae) on spotted cucumber beetle eggs and larvae (Coleoptera: Chrysomelidae). *Environmental Entomology* 27:366–372.
- Tamasi, E., A. Stokes, B. Lasserre, F. Danjon, S. Berthier, T. Fourcaud, and D. Chiatante. 2005. Influence of wind loading on root system development and architecture in oak (*Quercus robur* L.) seedlings. *Trees* 19:374–384.
- Tanada, Y., and H. Kaya. 1993. Insect Pathology. Academic Press, San Diego, CA.
- Tanaka, S., and Y. Suzuki. 1998. Physiological trade-offs between reproduction, flight capability and longevity in a wing-dimorphic cricket, *Modicogryllus confirmatus*. *Journal of Insect Physiology* 44:121–129.
- Tanaka, Y., J. Yoshimura, C. Simon, J.R. Cooley, and K. Tainaka. 2009. Allee effect in the selection of prime-numbered cycles in periodical cicadas. *Proceedings of the National Academy of Sciences, USA* 106:8975–8979.
- Tansley, A.G. 1935. The use and abuse of vegetational concepts and terms. *Ecology* 16:284–307.
- Tantawi, T.I., E.M. El-Kady, B. Greenberg, and H.A. El-Ghaffar. 1996. Arthropod succession on exposed rabbit carrion in Alexandria, Egypt. *Journal of Medical Entomology* 33:566–580.
- Tayasu, I., T. Abe, P. Eggleton, and D.E. Bignell. 1997. Nitrogen and carbon isotope ratios in termites: an indicator of trophic habit along the gradient from wood-feeding to soil-feeding. *Ecological Entomology* 22:343–351.
- Taylor, S.L., and D.A. MacLean. 2009. Legacy of insect defoliators: increased wind-related mortality two decades after a spruce budworm outbreak. *Forest Science* 55:256–267.
- Teal, J.M. 1957. Community metabolism in a temperate cold spring. *Ecological Monographs* 27:283–302.
- Teal, J.M. 1962. Energy flow in the salt marsh ecosystem of Georgia. *Ecology* 43:614–624.
- Temple, S.A. 1977. Plant–animal mutualism: coevolution with dodo leads to near extinction of plant. *Science* 197:885–886.
- Terborgh, J. 1973. On the notion of favorableness in plant ecology. *American Naturalist* 107:481–501.
- Terborgh, J. 1985. The vertical component of plant species diversity in temperate and tropical forests. *American Naturalist* 126:760–776.
- Thaler, J.S. 1999a. Jasmonic acid mediated interactions between plants, herbivores, parasitoids, and pathogens: a review of field experiments with tomato. In *Induced Plant Defenses Against Pathogens and Herbivores: Biochemistry, Ecology, and Agriculture* (A.A. Agrawal, S. Tuzun, and E. Bent, Eds.), pp. 319–334. American Phytopathological Society, St. Paul, MN.
- Thaler, J.S. 1999b. Jasmonate-inducible plant defenses cause increased parasitism of herbivores. *Nature* 399:686–687.
- Thaler, J.S., M.J. Stout, R. Karban, and S.S. Duffey. 2001. Jasmonate-mediated induced plant resistance affects a community of herbivores. *Ecological Entomology* 26:312–324.
- Thaler, J.S., M.A. Farag, P.W. Pare, and M. Dicke. 2002. Jasmonate-deficient plants have reduced direct and indirect defences against herbivores. *Ecology Letters* 5:764–774.
- Theis, N., and R.A. Raguso. 2005. The effect of pollination on floral fragrance in thistles. *Journal of Chemical Ecology* 31:2581–2600.
- Thies, C., and T. Tschardt. 1999. Landscape structure and biological control in agroecosystems. *Science* 285:893–895.
- Thies, C., I. Steffan-Dewenter, and T. Tschardt. 2003. Effects of landscape context on herbivory and parasitism at different spatial scales. *Oikos* 101:18–25.
- Thomas, C.D., and I. Hanski. 1997. Butterfly populations. In *Metapopulation Biology: Ecology, Genetics and Evolution* (I.A. Hanski, and M.E. Gilpin, Eds.), pp. 359–386. Academic Press, San Diego, CA.
- Thomas, J.A., M.G. Telfer, D.B. Roy, C.D. Preston, J.J.D. Greenwood, J. Asher, R. Fox, R.T. Clarke, and J.H. Lawton. 2004. Comparative losses of British butterflies, birds, and plants and the global extinction crisis. *Science* 303:1879–1881.
- Thomas, M.D., S.D. Wratten, and N.W. Sotherton. 1992. Creation of ‘island’ habitats in farmland to manipulate populations of beneficial arthropods: predator densities and species composition. *Journal of Applied Ecology* 29:524–531.
- Thompson, D.C., and K.T. Gardner. 1996. Importance of grasshopper defoliation period on southwestern blue grama-dominated rangeland. *Journal of Range Management* 49:494–498.
- Thorne, B.L. 1997. Evolution of eusociality in termites. *Annual Review of Ecology and Systematics* 28:27–54.
- Thorne, B.L., and J.F.A. Traniello. 2003. Comparative social biology of basal taxa of ants and termites. *Annual Review of Entomology* 48:283–306.
- Thornhill, R. 1976. Sexual selection and nuptial feeding behavior in *Bittacus apicalis* (Insecta: Mecoptera). *American Naturalist* 110:529–548.
- Throop, H.L., and M.T. Lerdau. 2004. Effects of nitrogen deposition on insect herbivory: implications for community and ecosystem processes. *Ecosystems* 7:109–133.

- Throop, H.L., E.A. Holland, W.J. Parton, D.S. Ojima, and C.A. Keough. 2004. Effects of nitrogen deposition and insect herbivory on patterns of ecosystem-level carbon and nitrogen dynamics: results from the CENTURY model. *Global Change Biology* 10:1092–1105.
- Tian, G., L. Brussaard, and B.T. Kang. 1995. Breakdown of plant residues with contrasting chemical compositions under humid tropical conditions: effects of earthworms and millipedes. *Soil Biology and Biochemistry* 27:277–280.
- Tilman, D. 1978. Cherries, ants, and tent caterpillars: timing of nectar production in relation to susceptibility of caterpillars to ant predation. *Ecology* 59:686–692.
- Tilman, D., and J.A. Downing. 1994. Biodiversity and stability in grasslands. *Nature* 367:363–365.
- Tilman, D., and S. Pacala. 1993. The maintenance of species richness in plant communities. In *Species Diversity in Ecological Communities: Historical and Geographic Perspectives* (R.E. Ricklefs, and D. Schluter, Eds.), pp. 13–25. University of Chicago Press, Chicago, IL.
- Tilman, D., J. Knops, D. Wedin, P. Reich, M. Ritchie, and E. Siemann. 1997. The influence of functional diversity and composition on ecosystem processes. *Science* 277:1300–1302.
- Tinbergen, L. 1960. The natural control of insects in pinewoods. I. factors influencing the intensity of predation by songbirds. *Archives Neerlandaises de Zoologie* 13:265–343.
- Tisdale, R.A., and M.R. Wagner. 1990. Effects of photoperiod, temperature, and humidity on oviposition and egg development of *Neodiprion fulviceps* (Hymenoptera: Diprionidae) on cut branches of ponderosa pine. *Environmental Entomology* 19:456–458.
- Tobin, P.C., A.M. Liebhold, and E.A. Roberts. 2007. Comparison of methods for estimating the spread of a non-indigenous species. *Journal of Biogeography* 34:305–312.
- Torchin, M.E., and C.E. Mitchell. 2004. Parasites, pathogens, and invasions by plants and animals. *Frontiers in Ecology and the Environment* 4:183–190.
- Torres, J.A. 1988. Tropical cyclone effects on insect colonization and abundance in Puerto Rico. *Acta Cientifica* 2:40–44.
- Torres, J.A. 1992. Lepidoptera outbreaks in response to successional changes after the passage of Hurricane Hugo in Puerto Rico. *Journal of Tropical Ecology* 8:285–298.
- Towne, W.F., and J.L. Gould. 1985. Magnetic field sensitivity in honeybees. In *Magnetite Biomineralization and Magnetoreception in Organisms* (J.L. Kirschvink, D.S. Jones, and B.J. MacFadden, Eds.), pp. 385–406. Plenum Press, New York, NY.
- Townsend, C.R., and R.N. Hughes. 1981. Maximizing net energy returns from foraging. In *Physiological Ecology: an Evolutionary Approach to Resource Use* (C.R. Townsend, and P. Calow, Eds.), pp. 86–108. Blackwell Scientific, Oxford, UK.
- Traniello, J.F.A., and S.K. Robson. 1995. Trail and territorial communication in social insects. In *Chemical Ecology of Insects 2* (R.T. Cardé, and W.J. Bell, Eds.), pp. 241–286. Chapman & Hall, New York, NY.
- Traugott, M.S., and N.E. Stamp. 1996. Effects of chlorogenic acid- and tomatine-fed prey on behavior of an insect predator. *Journal of Insect Behavior* 9:461–476.
- Trenberth, K.E. 1999. Atmospheric moisture recycling: role of advection and local evaporation. *Journal of Climate* 12:1368–1381.
- Treseder, K.K. 2008. Nitrogen additions and microbial biomass: a meta-analysis of ecosystem studies. *Ecology Letters* 11:1111–1120.
- Treuhaft, R.N., B.E. Law, and G.P. Asner. 2004. Forest attributes from radar interferometric structure and its fusion with optical remote sensing. *BioScience* 54:561–571.
- Trivers, R.L. 1971. The evolution of reciprocal altruism. *Quarterly Review of Biology* 46:35–57.
- Trlica, M.J., and L.R. Rittenhouse. 1993. Grazing and plant performance. *Ecological Applications* 3:21–23.
- Trouvelot, L. 1867. The American silk worm. *American Naturalist* 1:30–38, 85–94, 145–149.
- Trumble, J.T., and P.D. Jensen. 2004. Ovipositional response, developmental effects and toxicity of hexavalent chromium to *Magaselia scalaris*, a terrestrial detritivore. *Archives of Environmental Contamination and Toxicology* 46:372–376.
- Trumble, J., and M. Sorensen. 2008. Selenium and the elemental defense hypothesis. *New Phytologist* 177:569–572.
- Trumble, J.T., D.M. Kolodny-Hirsch, and I.P. Ting. 1993. Plant compensation for arthropod herbivory. *Annual Review of Entomology* 38:93–119.
- Tscharntke, T. 1992. Fragmentation of *Phragmites* habitats, minimum viable population size, habitat suitability, and local extinction of moths, midges, flies, aphids, and birds. *Conservation Biology* 6:530–536.
- Tscharntke, T., S. Thiessen, R. Dolch, and W. Boland. 2001. Herbivory, induced resistance, and interplant signal transfer in *Alnus glutinosa*. *Biochemical Systematics and Ecology* 29:1025–1047.
- Tscharntke, T., A.M. Klein, A. Kruess, I. Steffan-DeWenter, and C. Thies. 2005. Landscape perspectives on agricultural intensification and biodiversity—ecosystem service management. *Ecology Letters* 8:857–874.
- Tscharntke, T., R. Bommarco, Y. Clough, T.O. Crist, T. Kleijn, T.A. Rand, J.M. Tylianakis, S. van Nouhuys, and S. Vidal. 2007. Conservation biological control and enemy diversity on a landscape scale. *Biological Control* 43:294–309.

- Tschinkel, W.R. 1999. Sociometry and sociogenesis of colonies of the harvester ant, *Pogonomyrmex badius*: distribution of workers, brood and seeds within the nest in relation to colony size and season. *Ecological Entomology* 24:222–237.
- Tschinkel, W.R. 2004. The nest architecture of the Florida harvester ant, *Pogonomyrmex badius*. *Journal of Insect Science* 4:21.
- Tschinkel, W.R. 2005. The nest architecture of the ant, *Camponotus socius*. *Journal of Insect Science* 5:9.
- Tullis, K., and M.L. Goff. 1987. Arthropod succession in exposed carrion in a tropical rainforest on O'ahu Island, Hawai'i. *Journal of Medical Entomology* 24:332–339.
- Tumlinson, J.H., and P.E.A. Teal. 1987. Relationship of structure and function to biochemistry in insect pheromone systems. In *Pheromone Biochemistry* (G.D. Prestwich, and G.J. Blomquist, Eds.), pp. 3–26. Academic Press, Orlando, FL.
- Tumlinson, J.H., D.D. Hardee, R.C. Gueldner, A.C. Thompson, P.A. Hedin, and J.P. Minyard. 1969. Sex pheromones produced by male boll weevils: isolation, identification and synthesis. *Science* 166:1010–1012.
- Tuomi, J., P. Niemela, E. Haukioja, S. Siren, and S. Neuvonen. 1984. Nutrient stress: an explanation for plant anti-herbivore responses to defoliation. *Oecologia* 61:208–210.
- Turchin, P. 1988. The effect of host-plant density on the numbers of Mexican bean beetles, *Epilachna varivestis*. *American Midland Naturalist* 119:15–20.
- Turchin, P. 1990. Rarity of density dependence or population regulation with lags? *Nature* 344:660–663.
- Turchin, P. 1998. *Quantitative Analysis of Movement*. Sinauer Associates, Sunderland, MA.
- Turchin, P., A.D. Taylor, and J.D. Reeve. 1999. Dynamical role of predators in population cycles of a forest insect. *Science* 285:1068–1071.
- Turgeon, J.J., A. Roques, and P. de Groot. 1994. Insect fauna of coniferous seed cones: diversity, host plant interactions, and management. *Annual Review of Entomology* 39:179–212.
- Turlings, T.C.J., J.H. Tumlinson, and W.J. Lewis. 1990. Exploitation of herbivore-induced plant odors by host-seeking parasitic wasps. *Science* 250:1251–1253.
- Turlings, T.C.J., P.J. McCall, H.T. Alborn, and J.H. Tumlinson. 1993. An elicitor in caterpillar oral secretions that induces corn seedlings to emit chemical signals attractive to parasitic wasps. *Journal of Chemical Ecology* 19:411–425.
- Turlings, T.C.J., J.H. Loughrin, P.J. McCall, U.S.R. Röse, W.J. Lewis, and J.H. Tumlinson. 1995. How caterpillar-damaged plants protect themselves by attracting parasitizing wasps. *Proceedings of the National Academy of Sciences, USA* 92:4169–4174.
- Turnbow, R.H., R.N. Coulson, L. Hu, and R.F. Billings. 1982. Procedural Guide for Using the Interactive Version of the TAMBEETLE Model of Southern Pine Beetle Population and Spot Dynamics. Texas Agricultural Experiment Station, Miscellaneous Publication MP–1518, Texas A&M University, College Station, TX.
- Turner, D.P., W.D. Ritts, W.B. Cohen, T.K. Maeirsperger, S.T. Gower, A.A. Kirschbaum, S.W. Running, M. Zhao, S.C. Wofsy, A.L. Dunn, B.E. Law, J.L. Campbell, W.C. Oechel, H.J. Kwon, T.P. Meyers, E.E. Small, S.A. Kurc, and J.A. Gamon. 2005. Site-level evaluation of satellite-based terrestrial gross primary production and net primary production monitoring. *Global Change Biology* 11:666–684.
- Turner, G.B. 1970. The ecological efficiency of consumer populations. *Ecology* 51:741–742.
- Turner, M.G. 1989. Landscape ecology: the effect of pattern on process. *Annual Review of Ecology and Systematics* 20:171–197.
- Turell, M.J., D.J. Dohm, M.R. Sardelis, M.L. O'Guinn, T.G. Andreadis, and J.A. Blow. 2005. An update on the potential of North American mosquitoes (Diptera: Culicidae) to transmit West Nile virus. *Journal of Medical Entomology* 42:57–62.
- Tyler, C.M. 1995. Factors contributing to post-fire seedling establishment in chaparral: direct and indirect effects of fire. *Journal of Ecology* 83:1009–1020.
- Tylianakis, J.M., T. Tscharntke, and O.T. Lewis. 2007. Habitat modification alters the structure of tropical host–parasitoid food webs. *Nature* 445:202–205.
- Tylianakis, J.M., R.K. Didham, J. Bascompte, and D.A. Wardle. 2008. Global change and species interactions in terrestrial ecosystems. *Ecology Letters* 11:1351–1363.
- Tyndale-Biscoe, M. 1994. Dung burial by native and introduced dung beetles (Scarabaeidae). *Australian Journal of Agricultural Research* 45:1799–1808.
- Tyndale-Biscoe, M., and W.G. Vogt. 1996. Population status of the bush fly, *Musca vetustissima* (Diptera: Muscidae), and native dung beetles (Coleoptera: Scarabaeinae) in south-eastern Australia in relation to establishment of exotic dung beetles. *Bulletin of Entomological Research* 86:183–192.
- Tzean, S.S., L.S. Hsieh, and W.J. Wu. 1997. Atlas of Entomopathogenic Fungi from Taiwan. Council of Agriculture, Taipei, Taiwan, ROC.
- Ulanowicz, R.E. 1995. Utricularia's secret: the advantage of positive feedback in oligotrophic environments. *Ecological Modelling* 79:49–57.
- Urbas, P., M.V. Araújo, Jr., I.R. Leal, and R. Wirth. 2007. Cutting more from cut forests: edge effects on foraging and herbivory of leaf-cutting ants in Brazil. *Biotropica* 39:489–495.
- Uvarov, B.P. 1954. Present trends in locust research. Report of the Sixth Commonwealth Entomological Conference, pp.
- Vacas, S., C. Alfaro, V. Navarro-Llopis, M. Zarzo, and J. Primo. 2009. Study on the optimal pheromone release rate for attraction of *Chilo suppressalis*

- (Lepidoptera: Pyralidae). *Journal of Economic Entomology* 102:1094–1100.
- Valkama, E., J. Koricheva, and E. Oksanen. 2007. Effects of elevated O<sub>3</sub>, alone and in combination with elevated CO<sub>2</sub>, on tree leaf chemistry and insect herbivore performance: a meta-analysis. *Global Change Biology* 13:184–201.
- Vamosi, J.C., T.M. Knight, J.A. Steets, S.J. Mazer, M. Burd, and T.-L. Ashman. 2006. Pollination decays in biodiversity hotspots. *Proceedings of the National Academy of Sciences, USA* 103:956–961.
- Van Baaren, J., C. Le Lann, J. Pichenot, J.S. Pierre, L. Krespi, and Y. Outreman. 2009. How could host discrimination abilities influence the structure of a parasitoid community? *Bulletin of Entomological Research* 99:299–306.
- Van Bael, S.A., A. Aiello, A. Valderrama, E. Medianero, M. Samaniego, and S.J. Wright. 2004. General herbivore outbreak following an El Niño-related drought in a lowland Panamanian forest. *Journal of Tropical Ecology* 20:625–633.
- Van Bael, S.A., M.C. Valencia, E.I. Rojas, N. Gómez, D.M. Windsor, and E.A. Herre. 2009. Effects of foliar endophytic fungi on the preference and performance of the leaf beetle *Chelymorpha alternans* in Panama. *Biotropica* 41:221–225.
- van Biervliet, O., K. Wiśniewski, J. Daniels, and J.R. Vonesh. 2009. Effects of tea plantations on stream invertebrates in a global biodiversity hotspot in Africa. *Biotropica* 41:469–475.
- Van Cleve, K., and S. Martin. 1991. Long-term Ecological Research in the United States, 6<sup>th</sup> Ed. University of Washington, Seattle, WA.
- van Dam, N.M. 2009. Belowground herbivory and plant defenses. *Annual Review of Ecology, Evolution and Systematics* 40:373–391.
- van den Bosch, R., and V.M. Stern. 1962. The integration of chemical and biological control of arthropod pests. *Annual Review of Entomology* 7:367–386.
- van den Bosch, R., P.S. Messenger, and A.P. Gutierrez. 1982. An Introduction to Biological Control. Plenum Press, New York, NY.
- van der Maarel, E., and A. Titlyanova. 1989. Above-ground and below-ground biomass relations in steppes under different grazing conditions. *Oikos* 56:364–370.
- van der Zee, B., S.T. Behmer, and S.J. Simpson. 2002. Food mixing strategies in the desert locust: effects of phase, distance between foods, and food nutrient content. *Entomologia Experimentalis et Applicata* 103:227–237.
- Van Driesche, R.G., and T. Bellows. 1996. Biological Control. Chapman & Hall, New York, NY.
- Van Hook, Jr., R.I., M.G. Nielsen, and H.H. Shugart. 1980. Energy and nitrogen relations for a *Macrosiphum liriodendri* (Homoptera: Aphididae) population in an east Tennessee *Liriodendron tulipifera* stand. *Ecology* 61:960–975.
- Van Langevelde, R., C.A.D.M. van de Vijver, L. Kumar, J. van de Koppel, N. de Ridder, J. van Andel, A.K. Skidmore, J.W. Hearne, L. Stroosnijder, W.J. Bond, H.H.T. Prins, and M. Rietkerk. 2003. Effects of fire and herbivory on the stability of savanna ecosystems. *Ecology* 84:337–350.
- van Lenteren, J.C., J. Bale, F. Bigler, H.M.T. Hokkanen, and A.J.M. Loomans. 2006. Assessing risks of releasing exotic biological control agents of arthropod pests. *Annual Review of Entomology* 51:609–634.
- Vanni, M.J., and G.D. Layne. 1997. Nutrient recycling and herbivory as mechanisms in the “top–down” effect of fish on algae in lakes. *Ecology* 78:21–40.
- Vannote, R.L., G.W. Minshaw, K.W. Cummins, J.R. Sedell, and C.E. Cushing. 1980. The river continuum concept. *Canadian Journal of Fisheries and Aquatic Science* 37:130–137.
- Van Zandt, P.A., and A.A. Agrawal. 2004. Community-wide impacts of herbivore-induced plant responses in milkweed (*Asclepias syriaca*). *Ecology* 85:2616–2629.
- Vargas, R.I., J.C. Piñero, R.F.L. Mau, J.D. Stark, M. Hertlein, A. Mafra-Neto, R. Coler, and A. Getchell. 2009. Attraction and mortality of oriental fruit flies to SPLAT–MAT-methyl eugenol with spinosad. *Entomologia Experimentalis et Applicata* 131:286–293.
- Vargo, E.L., C. Husseneder, and J.K. Grace. 2003. Colony and population genetic structure of the Formosan subterranean termite, *Coptotermes formosanus*, in Japan. *Molecular Ecology* 12:2599–2608.
- Várkonyi, G., M. Kuussaari, and H. Lappalainen. 2003. Use of forest corridors by boreal *Xestia* moths. *Oecologia* 137:466–474.
- Varley, G.C., and G.R. Gradwell. 1970. Recent advances in insect population dynamics. *Annual Review of Entomology* 15:1–24.
- Varley, G.C., G.R. Gradwell, and M.P. Hassell. 1973. Insect Population Ecology: an Analytical Approach. Blackwell Scientific, Oxford, UK.
- Vasconcelos, H.L., E.H.M. Vieira-Neto, and F.M. Mundim. 2006. Roads alter the colonization dynamics of a keystone herbivore in Neotropical savannas. *Biotropica* 38:661–665.
- Veblen, T.T., K.S. Hadley, E.M. Nel, T. Kitzberger, M. Reid, and R. Villalba. 1994. Disturbance regime and disturbance interactions in a Rocky Mountain subalpine forest. *Journal of Ecology* 82:125–135.
- Via, S. 1990. Ecological genetics and host adaptation in herbivorous insects: the experimental study of evolution in natural and agricultural systems. *Annual Review of Entomology* 35:421–446.
- Via, S. 1991a. The genetic structure of host plant adaptation in a spatial patchwork: demographic variability among reciprocally transplanted pea aphid clones. *Evolution* 45:827–852.
- Via, S. 1991b. Specialized host plant performance of pea aphid clones is not altered by experience. *Ecology* 72:1420–1427.

- Vickerman, D.B., and J.T. Trumble. 2003. Biotransfer of selenium: effects on an insect predator, *Podisus maculiventris*. *Ecotoxicology* 12:497–504.
- Vickerman, D.B., J.K. Young, and J.T. Trumble. 2002. Effect of selenium-treated alfalfa on development, survival, feeding, and oviposition preferences of *Spodoptera exigua* (Lepidoptera: Noctuidae). *Environmental Entomology* 31:953–959.
- Vincent, C., G. Hallman, B. Panneton, and F. Fleurat-Lessard. 2003. Management of agricultural insects with physical control methods. *Annual Review of Entomology* 48:261–281.
- Vinson, M.R., and C.P. Hawkins. 1998. Biodiversity of stream insects: variation at local, basin, and regional scales. *Annual Review of Entomology* 43:271–293.
- Visser, J.H. 1986. Host odor perception in phytophagous insects. *Annual Review of Entomology* 31:121–144.
- Visser, M.E., and C. Both. 2005. Shifts in phenology due to global climate change: the need for a yardstick. *Proceedings of the Royal Society B* 272:2561–2569.
- Visser, M.E., and L.J.M. Holleman. 2001. Warmer springs disrupt the synchrony of oak and winter moth phenology. *Proceedings of the Royal Society B* 268:289–294.
- Vitousek, P. 1982. Nutrient cycling and nutrient use efficiency. *American Naturalist* 119:553–572.
- Vitousek, P.M., and D.U. Hooper. 1993. Biological diversity and terrestrial ecosystem biogeochemistry. In *Biodiversity and Ecosystem Function* (E.D. Schulze, and H.A. Mooney, Eds.), pp. 3–14. Springer-Verlag, Berlin, Germany.
- Vitousek, P.M., H.A. Mooney, J. Lubchenco, and J.M. Melillo. 1997. Human domination of Earth's ecosystems. *Science* 277:494–499.
- Vittor, A.Y., R.H. Gilman, J. Tielsch, G. Glass, T. Shields, W.S. Lozano, V. Pinedo-Cancino, and J.A. Patz. 2006. The effect of deforestation on the human-biting rate of *Anopheles darlingi*, the primary vector of falciparum malaria in the Peruvian Amazon. *American Journal of Tropical Medicine and Hygiene* 74:3–11.
- Voelckel, C., U. Schittko, and I.T. Baldwin. 2001. Herbivore-induced ethylene burst reduces fitness costs of jasmonate- and oral secretion-induced defenses in *Nicotiana attenuata*. *Oecologia* 127:274–280.
- Voelz, N.J., N.L. Poff, and J.V. Ward. 1994. Differential effects of a brief thermal disturbance on caddisflies (Trichoptera) in a regulated river. *American Midland Naturalist* 132:173–182.
- Volney, W.J.A., J.E. Milstead, and V.R. Lewis. 1983. Effect of food quality, larval density and photoperiod on the feeding rate of the California oakworm (Lepidoptera: Diopidae). *Environmental Entomology* 12:792–798.
- Volterra, V. 1926. Fluctuations in the abundance of a species considered mathematically. *Nature* 118:558–560.
- von Frisch, K. 1967. *The Dance Language and Orientation of Bees*. Harvard University Press, Cambridge, MA.
- Vossbrinck, C.R., D.C. Coleman, and T.A. Woolley. 1979. Abiotic and biotic factors in litter decomposition in a semiarid grassland. *Ecology* 60:265–271.
- Wäckers, F.L., C. Bonifay, and W.J. Lewis. 2002. Conditioning of appetitive behavior in the Hymenopteran parasitoid *Microplitis croceipes*. *Entomologia Experimentalis et Applicata* 103:135–138.
- Wagner, D. 1997. The influence of ant nests on *Acacia* seed production, herbivory and soil nutrients. *Journal of Ecology* 85:83–93.
- Wagner, D., and J.B. Jones. 2004. The contribution of harvester ant nests, *Pogonomyrmex rugosus* (Hymenoptera, Formicidae), to soil nutrient stocks and microbial biomass in the Mojave Desert. *Environmental Entomology* 33:599–607.
- Wagner, D., M.J.F. Brown, and D.M. Gordon. 1997. Harvest ant nests, soil biota and soil chemistry. *Oecologia* 112:232–236.
- Wagner, D.L. 2009. Ode to *Alabama*: the meteoric fall of a once extraordinarily abundant moth. *American Entomologist* 55:170–173.
- Wagner, R. 1991. The influence of the diel activity pattern of the larvae of *Sericostoma personatum* (Kirby & Spence) (Trichoptera) on organic matter distribution in stream sediments: a laboratory study. *Hydrobiologia* 224:65–70.
- Wagner, T.L., R.M. Feldman, J.A. Gagne, J.D. Cover, R.N. Coulson, and R.M. Schoolfield. 1981. Factors affecting gallery construction, oviposition, and re-emergence of *Dendroctonus frontalis* in the laboratory. *Annals of the Entomological Society of America* 74:255–273.
- Waide, R.B., M.R. Willig, G. Mittelbach, C. Steiner, L. Gough, S.I. Dodson, G.P. Judy, and R. Parmenter. 1999. The relationship between primary productivity and species richness. *Annual Review of Ecology and Systematics* 30:257–300.
- Walker, L.R., and M.R. Willig. 1999. An introduction to terrestrial disturbances. In *Ecosystems of the World 16: Ecosystems of Disturbed Ground* (L.R. Walker, Ed.), pp. 1–16. Elsevier, Amsterdam, The Netherlands.
- Wallace, A.R. 1876. *The Geographical Distribution of Animals, with a Study of the Relations of Living and Extinct Faunas as Elucidating the Past Changes of the Earth's Surface*. Macmillan, London, UK.
- Wallace, A.R. 1911. *Island Life, or the Phenomena and Causes of Insular Faunas and Floras Including a Revision and Attempted Solution of the Problem of Geological Climates*. Macmillan, London, UK.
- Wallace, J., and D. McJannet. 2010. Processes controlling transpiration in the rainforests of north Queensland, Australia. *Journal of Hydrology* 384:107–117.
- Wallace, J.B., and J.J. Hutchens, Jr. 2000. Effects of invertebrates in lotic ecosystem processes. In *Invertebrates as Webmasters in Ecosystems* (D.C. Coleman, and P. Hendrix, Eds.), pp. 99–114. CAB International, Wallingford, UK.



- Wallace, J.B., and J. O'Hop. 1985. Life on a fast pad: waterlily leaf beetle impact on water lilies. *Ecology* 66:1534–1544.
- Wallace, J.B., and J.R. Webster. 1996. The role of macroinvertebrates in stream ecosystem function. *Annual Review of Entomology* 41:115–139.
- Wallace, J.B., T.F. Cuffney, J.R. Webster, G.J. Lugthart, K. Chung, and G.S. Goldwitz. 1991. Export of fine organic particles from headwater streams: effects of season, extreme discharges, and invertebrate manipulation. *Limnology and Oceanography* 36:670–682.
- Wallace, J.B., J.R. Webster, and R.L. Lowe. 1992. High-gradient streams of the Appalachians. In *Biodiversity of Southeastern United States: Aquatic Communities* (C.T. Hackney, S.M. Adams, and W.A. Martin, Eds.), pp. 133–191. John Wiley, New York, NY.
- Wallace, J.B., M.R. Whiles, S. Eggert, T.F. Cuffney, G.J. Lugthart, and K. Chung. 1995. Long-term dynamics of coarse particulate organic matter in three Appalachian Mountain streams. *Journal of the North American Benthological Society* 14:217–232.
- Wallace, J.B., S.L. Eggert, J.L. Meyer, and J.B. Webster. 1997. Multiple trophic levels of a forest stream linked to terrestrial litter inputs. *Science* 277:102–104.
- Wallin, K.F., and K.F. Raffa. 2001. Effects of folivory on subcortical plant defenses: can defense theories predict interguild processes? *Ecology* 82:1387–1400.
- Wallner, W.E. 1996. Invasive pests ('biological pollutants') and US forests: whose problem, who pays? *EPPO Bulletin* 26:167–180.
- Waloff, N., and P. Thompson. 1980. Census data of populations of some leafhoppers (Auchenorrhyncha, Homoptera) of acid grassland. *Journal of Animal Ecology* 49:395–416.
- Walter, D.E., and D.J. O'Dowd. 1995. Life on the forest phyllophane: hairs, little houses, and myriad mites. In *Forest Canopies* (M.D. Lowman, and N.M. Nadkarni, Eds.), pp. 325–351. Academic Press, San Diego, CA.
- Walter, J.K., R.E. Bilby, and B.R. Fransen. 2006. Effects of Pacific salmon spawning and carcass availability on the caddisfly *Ecclisomyia conspersa* (Trichoptera: Limnephilidae). *Freshwater Biology* 51:1211–1218.
- Wang, Y., S. Mopper, and K. Hasenstein. 2001. Effects of salinity on endogenous ABA, IAA, JA, and SA in *Iris hexagona*. *Journal of Chemical Ecology* 27:327–342.
- Ward, J.V. 1992. *Aquatic Insect Ecology*. 1. Biology and Habitat. John Wiley & Sons, New York, NY.
- Ward, J.V., and J.A. Stanford. 1982. Thermal responses in the evolutionary ecology of aquatic insects. *Annual Review of Entomology* 27:97–117.
- Waring, G.L., and N.S. Cobb. 1992. The impact of plant stress on herbivore population dynamics. Bernays E.A., Ed.), *Plant–insect Interactions*, Vol. 4. pp. 167–226. CRC Press, Boca Raton, FL.
- Waring, G.L., and P.W. Price. 1990. Plant water stress and gall formation (Cecidomyiidae: *Asphondylia* spp.) on creosote bush (*Larrea tridentata*). *Ecological Entomology* 15:87–95.
- Waring, R.H., and G.B. Pitman. 1983. Physiological stress in lodgepole pine as a precursor for mountain pine beetle attack. *Zeitschrift für angewandte Entomologie* 96:265–270.
- Waring, R.H., and S.W. Running. 1998. *Forest Ecosystems: Analysis at Multiple Scales*. Academic Press, San Diego, CA.
- Warren, M.S., J.K. Hill, J.A. Thomas, J. Asher, R. Fox, B. Huntley, D.B. Roy, M.G. Telfer, S. Jeffcoate, P. Harding, G. Jeffcoate, S.G. Willis, J.N. Greatorex-Davies, D. Moss, and C.D. Thomas. 2001. Rapid responses of British butterflies to opposing forces of climate and habitat change. *Nature* 414:65–69.
- Wassenaar, L.I., and K.A. Hobson. 1998. Natal origins of migratory monarch butterflies at wintering colonies in Mexico: new isotopic evidence. *Proceedings of the National Academy of Sciences, USA* 95:15436–15439.
- Waterman, P.G. 2007. The current status of chemical systematics. *Phytochemistry* 68:2896–2903.
- Watson, E.J., and C.E. Carlton. 2003. Spring succession of necrophilous insects on wildlife carcasses in Louisiana. *Journal of Medical Entomology* 40:338–347.
- Watson, M.A., and H.L. Nixon. 1953. Studies on the feeding of *Myzus persicae* (Sulz.) on radioactive plants. *Annals of Applied Biology* 40:537–545.
- Watt, A.D., and A.M. McFarlane. 2002. Will climate change have a different impact on different trophic levels? Phenological development of winter moth *Opheroptera brumata* and its host plants. *Ecological Entomology* 27:254–256.
- Watt, A.D., J.B. Whittaker, M. Docherty, G. Brooks, E. Lindsay, and D.T. Salt. 1995. The impact of elevated atmospheric CO<sub>2</sub> on insect herbivores. In *Insects in a Changing Environment* (R. Harrington, and N.E. Stork, Eds.), pp. 197–217. Academic Press, London, UK.
- Webb, J.R., B.J. Cosby, F.A. Diviney, Jr., K.N. Eshleman, and J.N. Galloway. 1995. Change in the acid-base status of an Appalachian Mountain catchment following forest defoliation by the gypsy moth. *Water, Air and Soil Pollution* 85:535–540.
- Webb, W.L. 1978. Effects of defoliation and tree energetics. In *The Douglas-fir Tussock Moth: a Synthesis* (M.H. Brookes, R.W. Stark, and R.W. Campbell, Eds.), pp. 77–81. USDA Forest Service Technical Bulletin 1585, USDA Forest Service, Washington, DC.
- Webb, W.L., and J.J. Karchesy. 1977. Starch content of Douglas-fir defoliated by the tussock moth. *Canadian Journal of Forest Research* 7:186–188.
- Webb, W.L., W.K. Lauenroth, S.R. Szarek, and R.S. Kinerson. 1983. Primary production and abiotic

- controls in forests, grasslands, and desert ecosystems in the United States. *Ecology* 64:134–151.
- Weber, N.A. 1966. The fungus-growing ants. *Science* 121:587–604.
- Webster, J.R., J.B. Waide, and B.C. Patten. 1975. Nutrient recycling and the stability of ecosystems. In *Mineral Cycling in Southeastern Ecosystems. CONF-740513* (F.G. Howell, J.B. Gentry, and M.H. Smith, Eds.), pp. 1–27. USDOE Energy Research and Development Administration, Washington, DC.
- Wedin, D.A., L.L. Tieszen, B. Dewey, and J. Pastor. 1995. Carbon isotope dynamics during grass decomposition and soil organic matter formation. *Ecology* 76:1383–1392.
- Wegener, A.L. 1924. Entstehung der Kontinente und Ozeane. English Trans, 3<sup>rd</sup> Ed. Methuen, London, UK.
- Wehner, R. 2003. Desert ant navigation: how miniature brains solve complex tasks. *Journal of Comparative Physiology A* 189:579–588.
- Wehner, R., K. Gallizzi, C. Frei, and M. Vesely. 2002. Calibration processes in desert ant navigation: vector courses and systematic search. *Journal of Comparative Physiology A* 188:683–693.
- Wei, C.A., S.L. Rafalko, and F.C. Dyer. 2002. Deciding to learn: modulation of learning flight in honeybees, *Apis mellifera*. *Journal of Comparative Physiology A* 188:725–737.
- Weinstock, G.M., G.E. Robinson, and members of the Honeybee Genome Sequencing Consortium. 2006. Insights into social insects from the genome of the honeybee *Apis mellifera*. *Nature* 443:931–949.
- Weisser, W.W., and E., Siemann (Eds.) 2004. *Insects and Ecosystem Function*. Springer-Verlag, Berlin, Germany.
- Wellington, W.G. 1980. Dispersal and population change. In *Dispersal of Forest Insects: Evaluation, Theory and Management Implications. Proceedings International Union of Forest Research Organizations Conference* (A.A. Berryman, and L. Safranyik, Eds.), pp. 11–24. Washington State University Cooperative Extension Service, Pullman, WA.
- Wellington, W.G., P.J. Cameron, W.A. Thompson, I.B. Vertinsky, and A.S. Landsberg. 1975. A stochastic model for assessing the effects of external and internal heterogeneity of an insect population. *Researches in Population Ecology* 17:1–28.
- Wells, J.D., and B. Greenberg. 1994. Effect of the red imported fire ant (Hymenoptera: Formicidae) and carcass type on the daily occurrence of post-feeding cation-fly larvae (Diptera: Calliphoridae, Sarcophagidae). *Journal of Medical Entomology* 31:171–174.
- West, D.C., H.H., Shugart, and D.B., Botkin (Eds.) 1981. *Forest Succession: Concepts and Application*. Springer-Verlag, New York, NY.
- Westoby, M., K. French, L. Hughes, B. Rice, and L. Rodgeron. 1991. Why do more plant species use ants for dispersal on infertile compared with fertile soils? *Australian Journal of Ecology* 16:445–455.
- Weygoldt, P. 1969. *The Biology of Pseudoscorpions*. Harvard University Press, Cambridge, MA.
- Wheeler, G.S., M. Tokoro, R.H. Scheffrahn, and N.Y. Su. 1996. Comparative respiration and methane production rates in Nearctic termites. *Journal of Insect Physiology* 42:799–806.
- Wheelwright, N.T., and G.H. Orians. 1982. Seed dispersal by animals: contrasts with pollen dispersal, problems of terminology, and constraints on coevolution. *American Naturalist* 119:402–413.
- Whiles, M.R., M.A. Callahan, Jr., C.K. Meyer, B.L. Brock, and R.E. Charlton. 2001. Emergence of periodical cicadas (*Magicicada cassini*) from a Kansas riparian forest: densities, biomass and nitrogen flux. *American Midland Naturalist* 145:176–187.
- White, G.M., D.H. Boshier, and W. Powell. 2002. Increased pollen flow counteracts fragmentation in a tropical dry forest: an example from *Swietenia humilis* Zuccarini. *Proceedings of the National Academy of Sciences, USA* 99:2038–2042.
- White, P.S. 1988. Prickle distribution in *Aralia spinosa* (Araliaceae). *American Journal of Botany* 75:282–285.
- White, P.S., and S.T.A. Pickett. 1985. Natural disturbance and patch dynamics: an introduction. In *Ecology of Natural Disturbance and Patch Dynamics* (S.T.A. Pickett, and P.S. White, Eds.), pp. 3–13. Academic Press, New York, NY.
- White, T.C.R. 1969. An index to measure weather-induced stress of trees associated with outbreaks of psyllids in Australia. *Ecology* 50:905–909.
- White, T.C.R. 1976. Weather, food and plagues of locusts. *Oecologia* 22:119–134.
- White, T.C.R. 1984. The abundance of invertebrate herbivores in relation to the availability of nitrogen in stressed food plants. *Oecologia* 63:90–105.
- Whitford, W.G. 1978. Foraging by seed-harvesting ants. In *Production Ecology of Ants and Termites* (M.V. Brian, Ed.), pp. 107–110. Cambridge University Press, Cambridge, UK.
- Whitford, W.G. 1986. Decomposition and nutrient cycling in deserts. In *Pattern and Process in Desert Ecosystems* (W.G. Whitford, Ed.), pp. 93–117. University of New Mexico Press, Albuquerque, NM.
- Whitford, W.G. 1992. Effects of climate change on soil biotic communities and soil processes. In *Global Warming and Biological Diversity* (R.L. Peters, and T.E. Lovejoy, Eds.), pp. 124–136. Yale University Press, New Haven, CT.
- Whitford, W.G. 2000. Arthropods as keystone webmasters in desert ecosystems. In *Invertebrates as Webmasters in Ecosystems* (D.C. Coleman, and P. Hendrix, Eds.), pp. 99–114. CAB International, Wallingford, UK.

- Whitford, W.G., and E. Jackson. 2007. Seed harvester ants (*Pogonomyrmex rugosus*) as “pulse” predators. *Journal of Arid Environments* 70:549–552.
- Whitford, W.G., P. Johnson, and J. Ramirez. 1976. Comparative ecology of the harvester ants *Pogonomyrmex barbatus* (F. Smith) and *Pogonomyrmex rugosus* (Emery). *Insectes Sociaux* 23:117–132.
- Whitford, W.G., V. Meentemeyer, T.R. Seastedt, K. Cromack, Jr., D.A. Crossley, Jr., P. Santos, R.L. Todd, and J.B. Waide. 1981. Exceptions to the AET model: deserts and clear-cut forest. *Ecology* 62:275–277.
- Whitford, W.G., Y. Steinberger, and G. Ettershank. 1982. Contributions of subterranean termites to the “economy” of Chihuahuan Desert ecosystems. *Oecologia* 55:298–302.
- Whitham, T.G. 1983. Host manipulation of parasites: within-plant variation as a defense against rapidly evolving pests. In *Variable Plants and Herbivores in Natural and Managed Systems* (R.F. Denno, and M.S. McClure, Eds.), pp. 15–41. Academic Press, New York, NY.
- Whitham, T.G., W.P. Young, G.D. Martinsen, C.A. Gehring, J.A. Schweitzer, S.M. Shuster, G.M. Wimp, D.G. Fischer, J.K. Bailey, R.L. Lindroth, S. Woolbright, and C.R. Kuske. 2003. Community and ecosystem genetics: a consequence of the extended phenotype. *Ecology* 84:559–573.
- Whitham, T.G., J.K. Bailey, J.A. Schweitzer, S.M. Shuster, R.K. Bangert, C.J. LeRoy, E.V. Lonsdorf, G.J. Allan, S.P. DiFazio, B.M. Potts, D.G. Fischer, C.A. Gehring, R.L. Lindroth, J.C. Marks, S.C. Hart, G.M. Wimp, and S.C. Wooley. 2006. A framework for community and ecosystem genetics: from genes to ecosystems. *Nature Reviews Genetics* 7:510–523.
- Whittaker, R.H. 1953. A consideration of climax theory: the climax as a population and pattern. *Ecological Monographs* 23:41–78.
- Whittaker, R.H. 1970. *Communities and Ecosystems*. Macmillan, London, UK.
- Whittaker, R.H., and P.P. Feeny. 1971. Allelochemicals: chemical interactions between species. *Science* 171:757–770.
- Wickler, W. 1968. *Mimicry in Plants and Animals*. English translation by R. D. Martin. Weidenfeld and Nicolson, Ltd., London, UK.
- Wickman, B.E. 1964. Attack habits of *Melanophila consputa* on fire-killed pines. *Pan-Pacific Entomologist* 40:183–186.
- Wickman, B.E. 1980. Increased growth of white fir after a Douglas-fir tussock moth outbreak. *Journal of Forestry* 78:31–33.
- Wickman, B.E. 1992. *Forest Health in the Blue Mountains: the Influence of Insects and Diseases*. USDA Forest Serv. Gen. Tech. Rpt. PNW-GTR-295. USDA Forest Serv., Pacific Northwest Res. Stn, Portland, OR.
- Wiegert, R.G. 1964. Population energetics of meadow spittlebugs (*Philaenus spumarius* L.) as affected by migration and habitat. *Ecological Monographs* 34:217–241.
- Wiegert, R.G. 1968. Thermodynamic considerations in animal nutrition. *American Zoologist* 8:71–81.
- Wiegert, R.G., and F.C. Evans. 1967. Investigations of secondary productivity in grasslands. In *Secondary Productivity of Terrestrial Ecosystems: principles and methods* (K. Petrusewicz, Ed.), pp. 499–518. Panstwowe Wydawnictwo Naukowe, Warszawa, Poland.
- Wiegert, R.G., and C.E. Petersen. 1983. Energy transfer in insects. *Annual Review of Entomology* 28:455–486.
- Wiens, J.J., C.H. Graham, D.S. Moen, S.A. Smith, and T.W. Reeder. 2006. Evolutionary and ecological causes of the latitudinal diversity gradient in hylid frogs: treefrog trees unearth the roots of high tropical diversity. *American Naturalist* 168:579–596.
- Wiggins, G.B., R.J. MacKay, and I.M. Smith. 1980. Evolutionary and ecological strategies of animals in annual temporary pools. *Archiv für Hydrobiologie Supplement* 58:97–206.
- Wikars, L.-O., and J. Schimmel. 2001. Immediate effects of fire-severity on soil invertebrates in cut and uncut pine forests. *Forest Ecology and Management* 141:189–200.
- Wiklund, C., and M. Friberg. 2009. The evolutionary ecology of generalization: among-year variation in host plant use and offspring survival in a butterfly. *Ecology* 90:3406–3417.
- Wilf, P., and C.C. Labandeira. 1999. Response of plant–insect associations to Paleocene–Eocene warming. *Science* 284:2153–2156.
- Wilf, P., C.C. Labandeira, K.R. Johnson, P.D. Coley, and A.D. Cutter. 2001. Insect herbivory, plant defense, and early Cenozoic climate change. *Proceedings of the National Academy of Sciences, USA* 98:6221–6226.
- Willers, J.L., J.N. Jenkins, W.L. Ladner, P.D. Gerard, D.L. Boykin, K.B. Hood, P.L. McKibben, S.A. Samson, and M.M. Bethel. 2005. Site specific approaches to cotton insect control. Sampling and remote sensing analysis techniques. *Precision Agriculture* 6:431–452.
- Williams, D.W., and A.M. Liebhold. 1995. Forest defoliators and climatic change: potential changes in spatial distribution of outbreaks of western spruce budworm (Lepidoptera: Tortricidae) and gypsy moth (Lepidoptera: Lymantriidae). *Environmental Entomology* 24:1–9.
- Williams, D.W., and A.M. Liebhold. 2002. Climate change and the outbreak ranges of two North American bark beetles. *Agricultural and Forest Entomology* 4:87–99.
- Williams, K.S., and C. Simon. 1995. The ecology, behavior, and evolution of periodical cicadas. *Annual Review of Entomology* 40:269–295.
- Williams, N.M., and C. Kremen. 2007. Resource distributions among habitats determine solitary bee offspring production in a mosaic landscape. *Ecological Applications* 17:910–921.

- Williamson, M. 1972. *The Analysis of Biological Populations*. Edward Arnold, London, UK.
- Williamson, S.C., J.K. Detling, J.L. Dodd, and M.I. Dyer. 1989. Experimental evaluation of the grazing optimization hypothesis. *Journal of Range Management* 42:149–152.
- Willig, M.R., and G.R. Camilo. 1991. The effect of Hurricane Hugo on six invertebrate species in the Luquillo Experimental Forest of Puerto Rico. *Biotropica* 23:455–461.
- Willig, M.R., and S.K. Lyons. 1998. An analytical model of latitudinal gradient in species richness with an empirical test for marsupials and bats in the New World. *Oikos* 81:93–98.
- Willig, M.R., and M.A. McGinley. 1999. Animal responses to natural disturbance and roles as patch generating phenomena. In *Ecosystems of the World: Ecosystems of Disturbed Ground* (L.R. Walker, Ed.), pp. 667–689. Elsevier Science, Amsterdam, The Netherlands.
- Willig, M.R., and L.R. Walker. 1999. Disturbance in terrestrial ecosystems: salient themes, synthesis, and future directions. In *Ecosystems of the World: Ecosystems of Disturbed Ground* (L.R. Walker, Ed.), pp. 747–767. Elsevier Science, Amsterdam, The Netherlands.
- Willmer, P.G., J.P. Hughes, J.A.T. Woodford, and S.C. Gordon. 1996. The effects of crop microclimate and associated physiological constraints on the seasonal and diurnal distribution patterns of raspberry beetle (*Byturus tomentosus*) on the host plant *Rubus idaeus*. *Ecological Entomology* 21:87–97.
- Wilson, D., and S.H. Faeth. 2001. Do fungal endophytes result in selection for leafminer ovipositional preference? *Ecology* 82:1097–1111.
- Wilson, D.S. 1976. Evolution on the level of communities. *Science* 192:1358–1360.
- Wilson, D.S. 1997. Biological communities as functionally organized units. *Ecology* 78:2018–2024.
- Wilson, E.O. 1969. The species equilibrium. In *Diversity and Stability in Ecological Systems. Brookhaven Symposium in Biology* 22 (G.M. Woodwell, and H.H. Smith, Eds.), pp. 38–47. Brookhaven National Laboratory, Upton, NY.
- Wilson, E.O. 1973. Group selection and its significance for ecology. *BioScience* 23:631–638.
- Wilson, E.O. 1975. *Sociobiology: the New Synthesis*. Belknap Press of Harvard University Press, Cambridge, MA.
- Wilson, E.O. 1992. *The Diversity of Life*. Harvard University Press, Cambridge, MA.
- Wilson, E.O., and T. Eisner. 1957. Quantitative studies of liquid food transmission in ants. *Insectes Sociaux* 4:157–166.
- Wilson, E.O., and D.S. Simberloff. 1969. Experimental zoogeography of islands: defaunation and monitoring techniques. *Ecology* 50:267–278.
- Wilson, M.V., P.C. Hammond, and C.B. Schultz. 1997. The interdependence of native plants and Fender's blue butterfly. In *Conservation and Management of Native Plants and Fungi* (T.N. Kaye, A. Liston, R.M. Love, D.L. Luoma, R.J. Meinke, and M.V. Wilson, Eds.), pp. 83–87. Native Plant Society of Oregon, Corvallis, OR.
- Wimp, G.M., S. Wooley, R.K. Bangert, W.P. Young, G.D. Martinsen, P. Keim, B. Rehill, R.L. Lindroth, and T.G. Whitham. 2007. Plant genetics predicts intra-annual variation in phytochemistry and arthropod community structure. *Molecular Ecology* 16:5057–5069.
- Winchester, N.N. 1997. Canopy arthropods of coastal Sitka spruce trees on Vancouver Island, British Columbia, Canada. In *Canopy Arthropods* (N.E. Stork, J. Adis, and R.K. Didham, Eds.), pp. 151–168. Chapman & Hall, London, UK.
- Winchester, N.N., V. Behan-Pelletier, and R.A. Ring. 1999. Arboreal specificity, diversity and abundance of canopy-dwelling oribatid mites (Acari: Oribatida). *Pedobiologia* 43:391–400.
- Windsor, D.M. 1990. *Climate and Moisture Variability in a Tropical Forest: Long-term Records from Barro Colorado Island, Panamá*. Smithsonian Institution Press, Washington, DC.
- Winfree, R., N.M. Williams, J. Dushoff, and C. Kremen. 2007. Native bees provide insurance against ongoing honey bee losses. *Ecology Letters* 10:1105–1113.
- Wint, G.R.W. 1983. Leaf damage in tropical rain forest canopies. In *Tropical Rain Forest: Ecology and Management* (S.L. Sutton, T.C. Whitmore, and A.C. Chadwick, Eds.), pp. 229–240. Blackwell Scientific, Oxford, UK.
- Winter, C., S. Lehmann, and M. Diekmann. 2008. Determinants of reproductive success: a comparative study of five endangered river corridor plants in fragmented habitats. *Biological Conservation* 141:1095–1104.
- Winter, K., and J.A.C. Smith. 1996. An introduction to crassulacean acid metabolism: biochemical principles and ecological diversity. In *Crassulacean Acid Metabolism: Biochemistry, Ecophysiology, and Evolution* (K. Winter, and J.A.C. Smith, Eds.), pp. 1–13. Springer-Verlag, New York, NY.
- Wipfli, M.S. 1997. Terrestrial invertebrates as salmonid prey and nitrogen sources in streams: contrasting old-growth and young-growth riparian forests in southeastern Alaska, U.S.A.. *Canadian Journal of Fisheries and Aquatic Science* 54:1259–1269.
- Wipfli, M.S., and J. Musslewhite. 2004. Density of red alder (*Alnus rubra*) in headwaters influences invertebrate and detritus subsidies to downstream fish habitats in Alaska. *Hydrobiologia* 520:153–163.
- Wipfli, M.S., J.S. Richardson, and R.J. Naiman. 2007. Ecological linkages between headwaters and downstream ecosystems: transport of organic matter, invertebrates, and wood down headwater channels.

- Journal of the American Water Resources Association* 43:72–85.
- Wisdom, C.S., C.S. Crawford, and E.F. Aldon. 1989. Influence of insect herbivory on photosynthetic area and reproduction in *Gutierrezia* species. *Journal of Ecology* 77:685–692.
- Wise, D.H. 1975. Food limitation of the spider *Linyphia marginata*: experimental field studies. *Ecology* 56:637–646.
- Wise, D.H., and M. Schaefer. 1994. Decomposition of leaf litter in a mull beech forest: comparison between canopy and herbaceous species. *Pedobiologia* 38:269–288.
- Wise, D.H., D.M. Moldenhauer, and J. Halaj. 2006. Using stable isotopes to reveal shifts in prey consumption by generalist predators. *Ecological Applications* 16:865–876.
- Wise, M.J. 2009. Competition among herbivores of *Solanum carolinense* as a constraint on the evolution of host-plant resistance. *Evolutionary Ecology* 23:347–361.
- Wissinger, S.A., and J. McGrady. 1993. Intra-guild predation and competition between larval dragonflies: direct and indirect effects of shared prey. *Ecology* 74:207–218.
- Witcosky, J.J., T.D. Schowalter, and E.M. Hansen. 1986. The influence of time of precommercial thinning on the colonization of Douglas-fir by three species of root-colonizing insects. *Canadian Journal of Forest Research* 16:745–749.
- Witkamp, M. 1971. Soils as components of ecosystems. *Annual Review of Ecology and Systematics* 2:85–110.
- Witkamp, M., and D.A. Crossley, Jr. 1966. The role of microarthropods and microflora in the breakdown of white oak litter. *Pedobiologia* 6:293–303.
- Witkamp, M., and J.S. Olson. 1963. Breakdown of confined and unconfined oak litter. *Oikos* 14:138–147.
- Witmer, M.C., and A.S. Cheke. 1991. The dodo and the tambalocoque tree: an obligate mutualism reconsidered. *Oikos* 61:133–137.
- Wold, E.N., and R.J. Marquis. 1997. Induced defense in white oak: effects on herbivores and consequences for the plant. *Ecology* 78:1356–1369.
- Wood, D.M., and M.C. Andersen. 1990. The effect of predispersal seed predators on colonization of *Aster ledophyllus* on Mount St. Helens, Washington. *American Midland Naturalist* 123:193–201.
- Wood, T.E., D. Lawrence, D.A. Clark, and R.L. Chazdon. 2009. Rain forest nutrient cycling and productivity in response to large-scale litter manipulation. *Ecology* 90:109–121.
- Wood, T.K. 1976. Alarm behavior of brooding female *Umbohia crassicornis* (Homoptera: Membracidae). *Annals of the Entomological Society of America* 69:340–344.
- Woods, P.V., and R.J. Raison. 1982. An appraisal of techniques for the study of litter decomposition in eucalypt forests. *Australian Journal of Ecology* 7:215–225.
- Woods, P.V., and R.J. Raison. 1983. Decomposition of litter in sub-alpine forests of *Eucalyptus delegatensis*, *E. pauciflora* and *E. dives*. *Australian Journal of Ecology* 8:287–299.
- Woodwell, F.I. 1993. How many species are required for a functional ecosystem? In *Biodiversity and Ecosystem Function* (E.D. Schulze, and H.A. Mooney, Eds.), pp. 271–291. Springer-Verlag, Berlin, Germany.
- Woolhouse, H.W. 1981. Aspects of the carbon and energy requirements of photosynthesis considered in relation to environmental constraints. In *Physiological Ecology: an Evolutionary Approach to Resource Use* (C.R. Townsend, and P. Calow, Eds.), pp. 51–85. Blackwell Scientific, Oxford, UK.
- Wotton, R.S., B. Malmqvist, T. Muotka, and K. Larsson. 1998. Fecal pellets from a dense aggregation of suspension-feeders in a stream: an example of ecosystem engineering. *Limnology and Oceanography* 43:719–725.
- Wright, L.C., A.A. Berryman, and B.E. Wickman. 1986. Abundance of the fir engraver, *Scolytus ventralis*, and the Douglas-fir beetle, *Dendroctonus pseudotsugae*, following tree defoliation by the Douglas-fir tussock moth, *Orgyia pseudotsugata*. *Canadian Entomologist* 116:293–305.
- Wynne-Edwards, V.C. 1963. Intergroup selection in the evolution of social systems. *Nature* 200:623–626.
- Wynne-Edwards, V.C. 1965. Self-regulating systems in populations of animals. *Science* 147:1543–1548.
- Wystrach, A., and G. Beugnon. 2009. Ants learn geometry and features. *Current Biology* 19:61–66.
- Xiao, J., Q. Zhuang, D.D. Baldocchi, B.E. Law, A.D. Richardson, J. Chen, R. Oren, G. Starr, A. Noormets, S. Ma, S.B. Verma, S. Wharton, S.C. Wofsy, P.V. Bolstad, S.P. Burns, D.R. Cook, P.S. Curtis, B.G. Drake, M. Falk, M.L. Fischer, D.R. Foster, L. Gu, J.L. Hadley, D.Y. Hollinger, G.G. Katul, M. Litvak, T.A. Martin, R. Matamala, S. McNulty, T.P. Meyers, R.K. Monson, J.W. Munger, W.C. Oechel, K.T. Paw U, H.P. Schmid, R.L. Scott, G. Sun, A.E. Suyker, and M.S. Torn. 2008. Estimation of net ecosystem carbon exchange for the coterminous United States by combining MODIS and AmeriFlux data. *Agricultural and Forest Meteorology* 148:1827–1847.
- Yamanaka, T., and A.M. Liebhold. 2009. Spatially implicit approaches to understand the manipulation of mating success for insect invasion management. *Population Ecology* 51:427–444.
- Yang, G.-H. 2005. Harm of introducing the western honeybee *Apis mellifera* L. to the Chinese honeybee *Apis cerana* F. and its ecological impact. *Acta Entomologica Sinica* 48:401–406 in Chinese with English summary.
- Yang, M.-X., Z.-W. Wang, H. Li, Z.-Y. Zhang, K. Tan, S.E. Radloff, and H.R. Hepburn. 2010. Thermoregulation in mixed-species colonies of honeybees

- (*Apis cerana* and *Apis mellifera*). *Journal of Insect Physiology* 56:706–709.
- Yang, S., J.G. Bishop, and M.S. Webster. 2008. Colonization genetics of an animal-dispersed plant (*Vaccinium membranaceum*) at Mount St. Helens, Washington. *Molecular Ecology* 17:731–740.
- Yee, D.A., and M.R. Willig. 2007. Colonisation of *Heliconia caribaea* by aquatic invertebrates: resource and microsite characteristics. *Ecological Entomology* 32:603–612.
- Yen, A.L. 2009. Entomophagy and insect conservation: some thoughts for digestion. *Journal of Insect Conservation* 13:667–670.
- Yoder, J.A., G.C. Theriot, and D.B. Rivers. 1996. Venom from *Nasonia vitripennis* alters water loss from the flesh fly, *Sarcophaga bullata*. *Entomologia Experimentalis et Applicata* 81:235–238.
- Yodzis, P. 1980. The connectance of real ecosystems. *Nature* 284:544–545.
- Yokoyama, K., H. Kai, and H. Tsuchiyama. 1991. Paracoprid dung beetles and gaseous loss of nitrogen from cow dung. *Soil Biology and Biochemistry* 23:643–647.
- Yorks, T.E., D.J. Leopold, and D.J. Raynal. 2003. Effects of *Tsuga canadensis* mortality on soil water chemistry and understory vegetation: possible consequences of an invasive insect herbivore. *Canadian Journal of Forest Research* 33:1525–1537.
- Yuan, W., S. Liu, G. Zhou, G. Zhou, L.L. Tieszen, D. Baldocchi, C. Bernhofer, H. Gholz, A.H. Goldstein, M.L. Goulden, D.Y. Hollinger, Y. Hu, B.E. Law, P.C. Stoy, T. Vesala, and S.C. Wofsy. 2007. Deriving a light use efficiency model from eddy covariance flux data for predicting daily gross primary production across biomes. *Agricultural and Forest Meteorology* 143:189–207.
- Zabel, J., and T. Tschardt. 1998. Does fragmentation of *Urtica* habitats affect phytophagous and predatory insects differentially? *Oecologia* 116:419–425.
- Zaidi, R.H., Z. Jaal, N.J. Hawkes, J. Hemingway, and W.O.C. Symondson. 1999. Can multiple-copy sequences of prey DNA be detected amongst the gut contents of invertebrate predators? *Molecular Ecology* 8:2081–2087.
- Zalucki, M.P., L.P. Brower, and A. Alonso-M. 2001. Detrimental effects of latex and cardiac glycosides on survival and growth of first-instar monarch butterfly larvae *Danaus plexippus* feeding on the sandhill milkweed *Asclepias humistrata*. *Ecological Entomology* 26:212–224.
- Zangerl, A.R., D. McKenna, C.L. Wraight, M. Carroll, P. Ficarello, R. Warner, and M.R. Berenbaum. 2001. Effects of exposure to event 176 *Bacillus thuringiensis* corn pollen on monarch and black swallowtail caterpillars under field conditions. *Proceedings of the National Academy of Sciences, USA* 98:11908–11912.
- Zaragoza, S.R., W.G. Whitford, and Y. Steinberger. 2007. Effects of temporally persistent ant nests on soil protozoan communities and the abundance of morphological types of amoeba. *Applied Soil Ecology* 37:81–87.
- Zavala, J.A., C.L. Casteel, E.H. DeLucia, and M.R. Berenbaum. 2008. Anthropogenic increase in carbon dioxide compromises plant defense against invasive insects. *Proceedings of the National Academy of Sciences, USA* 105:5129–5133.
- Zehnder, C.B., and M.D. Hunter. 2008. Effects of nitrogen deposition on the interaction between an aphid and its host plant. *Ecological Entomology* 33:24–30.
- Zehnder, C.B., and M.D. Hunter. 2009. More is not necessarily better: the impact of limiting and excessive nutrients on herbivore population growth rates. *Ecological Entomology* 34:535–543.
- Zeng, R.S., Z. Wen, G. Niu, M.A. Schuler, and M.R. Berenbaum. 2009. Enhanced toxicity and induction of cytochrome P450s suggest a cost of “eavesdropping” in a multitrophic interaction. *Journal of Chemical Ecology* 35:526–532.
- Zenk, M.H., and M. Juenger. 2007. Evolution and current status of the phytochemistry of nitrogenous compounds. *Phytochemistry* 68:2757–2772.
- Zera, A.J., and R.F. Denno. 1997. Physiology and ecology of dispersal polymorphism in insects. *Annual Review of Entomology* 42:207–230.
- Zera, A.J., and Z. Zhao. 2006. Intermediary metabolism and life-history trade-offs: differential metabolism of amino acids underlies the dispersal–reproduction trade-off in a wing-polymorphic cricket. *American Naturalist* 167:889–900.
- Zeringue, Jr., H.J. 1987. Changes in cotton leaf chemistry induced by volatile elicitors. *Phytochemistry* 26:1357–1360.
- Zettler, J.A., M.D. Taylor, C.R. Allen, and T.P. Spira. 2004. Consequences of forest clear-cuts for native and nonindigenous ants. *Annals of the Entomological Society of America* 97:513–518.
- Zhang, J., Y. Hu, X. Xiao, P. Chen, S. Han, G. Song, and G. Yu. 2009. Satellite-based estimation of evapotranspiration of an old-growth temperate mixed forest. *Agricultural and Forest Meteorology* 149:976–984.
- Zhang, Q.-H., and F. Schlyter. 2004. Olfactory recognition and behavioural avoidance of angiosperm nonhost volatiles by conifer-inhabiting bark beetles. *Agricultural and Forest Entomology* 6:1–19.
- Zhong, H., and T.D. Schowalter. 1989. Conifer bole utilization by wood-boring beetles in western Oregon. *Canadian Journal of Forest Research* 19:943–947.
- Zhong, H., Z. Yan, F. Jones, and C. Brock. 2003. Ecological analysis of mosquito light trap collections from west central Florida. *Environmental Entomology* 32:807–815.

- Zhou, H.-B., J.-L. Chen, D.-F. Cheng, Y. Liu, and J.-R. Sun. 2009. Effects of wheat-pea intercropping on the population dynamics of *Sitobion avenae* (Homoptera: Aphididae) and its main natural enemies. *Acta Entomologica Sinica* 52:775–782 in Chinese with English summary.
- Zhou, J., W.K.-M. Lau, P.M. Masuoka, R.G. Andre, J. Chamberlin, P. Lawyer, and L.W. Laughlin. 2002. El Niño helps spread Bartonellosis epidemics in Peru. *EOS, Transactions, American Geophysical Union* 83:157 160–161.
- Zimmerman, J.K., M.R. Willig, L.R. Walker, and W.L. Silver. 1996. Introduction: disturbance and Caribbean ecosystems. *Biotropica* 28:414–423.
- Zimmerman, J.K., L.S. Comita, J. Thompson, M. Uriarte, and N. Brokaw. 2010. Patch dynamics and community metastability of a subtropical forest: compound effects of natural disturbance and human land use. *Landscape Ecology* 25:1099–1111.
- Zimmerman, P.R., J.P. Greenberg, S.O. Wandiga, and P.J. Crutzen. 1982. Termites: a potentially large source of atmospheric methane, carbon dioxide, and molecular hydrogen. *Science* 218:563–565.
- Zjhra, M.L. 2008. Facilitating sympatric species coexistence via pollinator partitioning in endemic tropical trees of Madagascar. *Plant Systematics and Evolution* 271:157–176.
- Zlotin, R.I., and K.S. Khodashova. 1980. The Role of Animals in Biological Cycling of Forest-steppe Ecosystems. English translation. N. R. French. Dowden, Hutchinson & Ross, Stroudsburg, PA.

# AUTHOR INDEX

---

## A

- Abrams, P.A. 242  
Ackerman, A.S. 50  
Ackerman, I.L. 441, 444, 450  
Adams, J.M. 498, 509  
Adams, T.S. 269  
Adler, L.S. 245  
Adler, P.H. 40, 200  
Aerts, R. 428  
Agee, J.K. 27, 305, 309, 474  
Agrawal, A.A. 61, 81, 517  
Ågren, G.I. 425  
Agustí, N. 269  
Aide, T.M. 363, 365, 368  
Aizen, M.A. 398, 402, 406, 408, 488, 505, 509  
Akiyama, T. 376  
Alfaro, C. 499  
Alfaro, R.I. 365 374, 472  
Algar, A.C. 277  
Allan, B.F. 220, 499–500, 507  
Allan, J.D. 4, 228, 257–258, 287, 483  
Allee, W.C. 174  
Allen, A.P. 97, 277  
Allen, C.R. 49, 227, 509  
Allen, E.B. 248–249, 254  
Alstad, D.N. 11, 28, 35, 39, 46, 48, 136, 139, 168, 200, 244, 496  
Altieri, M.A. 494, 521  
Altizer, S.M. 234  
Amaranthus, M.P. 507  
Amman, G.D. 28, 198  
Amoo, A.O.J. 4, 236  
Andersen, A.N. 360, 415, 417, 505, 510  
Andersen, D.C. 306  
Andersen, P.C. 362  
Anderson, J.M. 424, 426, 440–441, 446  
Anderson, K.E. 246  
Anderson, N.H. 423, 425–426, 428, 433  
Anderson, V.J. 381  
Andreae, M.O. 50  
Andresen, E. 49, 411  
Andreux, F. 425  
Andrewartha, H.G. 18, 171, 186  
Andrews, W.V. 185, 485, 508  
Anelli, C.M. 4, 485  
Anstey, M.L. 41–42, 129, 145  
Appanah, S. 400, 404  
Aranibar, J.N. 400, 404  
Archer, S. 405  
Ardón, M. 387  
Arim, M. 270 272  
Arnfield, A.J. 210, 501, 503  
Arnone, III, J.A. 11, 38, 46, 75, 244  
Asquith, N.M. 413, 418  
Auclair, J.L. 95, 362  
Ausmus, B.S. 4, 56, 301, 422, 427  
Autry, A.R. 440  
Axelrod, R. 111, 454, 456–457, 462  
Ayres, E. 373, 392  
Ayres, M.P. 239, 252  
Bach, C.E. 369, 371, 381  
Bailey, J.K. 459–460  
Baker, R.R. 112–113  
Balanyá, J. 46, 459, 510–511  
Baldwin, D.H. 492  
Baldwin, I.T. 4, 54, 70, 247, 364, 374, 462  
Bale, J.S. 46  
Balvanera, P. 398  
Bangert, R.K. 285  
Banks, C.J. 95, 362  
Barbehenn, R. 59, 78  
Barbosa, P. 56, 142, 382, 493–494  
Bardgett, R.D. 381, 382, 385  
Barker, J.S. 427  
Barras, S.J. 252  
Barz, W. 430  
Bascompte, J. 490, 505, 508  
Baskerville, G.L. 32  
Basset, Y. 191, 258, 272, 278–279  
Batra, L.R. 4, 239  
Batzer, D.P. 24, 39–40, 190, 208, 245, 286, 507  
Baum, K.A. 195, 199, 203  
Baumann, P. 76, 239  
Bawa, K.S. 398–399, 404–405, 408  
Baxter, C.V. 4, 228, 257, 287, 329, 333, 483–484, 504, 507, 509  
Bayliss-Smith, T.P. 338  
Bazykin, A.D. 174  
Bazzaz, F.A. 75, 168, 244, 261, 262, 279, 299  
Beard, K.H. 172, 286, 294  
Beare, M.H. 274, 465  
Beaver, L.M. 31  
Bebi, P. 393–394  
Becerra, J.X. 61, 78–79, 81, 267  
Bede, J.C. 78  
Beedlow, P.A. 11, 49  
Begon, M. 143, 151, 163, 171, 174, 231  
Behan, V.M. 436  
Behmer, S.T. 55, 75–78, 80, 83, 97, 99, 100  
Bell, G. 28 136–137, 174  
Bell, W.J. 83–85, 100, 108  
Belle-Isle, J. 380  
Belnap, J. 349, 352  
Belovsky, G.E. 373, 374, 375, 377, 390, 471–472  
Belsky, A.J. 375  
Bender, M.A. 45  
Benedek, S. 260



- Benedict, F. 366  
 Benke, A.C. 355  
 Bennett, A. 415  
 Benstead, J.P. 30, 45, 297  
 Berenbaum, M.R. 54, 78  
 Berlow, E.L. 231, 242  
 Bernays, E.A. 78, 80  
 Bernhard-Reversat, F. 426  
 Berryman, A.A. 130, 142,  
     159–160, 163, 170, 174, 175,  
     176, 177  
 Bezemer, T.M. 38, 46, 75, 246  
 Biesmeijer, J.C. 397, 398, 490,  
     505, 508  
 Biondini, M.E. 267  
 Birk, E.M. 426, 428  
 Birks, H.J.B. 278, 282  
 Bisch-Knaden, S. 91  
 Bishop, J.A. 34  
 Bishop, J.G. 306, 379  
 Bjorksten, T.A. 90  
 Blanchette, R.A. 430  
 Blanton, C.M. 275  
 Blatt, S.E. 304, 306, 310  
 Bloesch, U. 450  
 Blossy, B. 373  
 Blum, M.S. 61, 66–67, 69, 78,  
     116–117  
 Blumberg, A.J.Y. 56  
 Blumer, P. 361, 362, 367  
 Blüthgen, N. 269  
 Boddum, T. 498  
 Boecklen, W.J. 188, 205,  
     206, 504  
 Boethel, D.J. 246  
 Boggs, C.L. 96  
 Boman, H.G. 69  
 Bonada, N. 510  
 Bond, W.J. 252, 286  
 Bongiovanni, R. 499  
 Boorman, S.A. 456  
 Boring, L.R. 308, 463  
 Bormann, F.H. 338, 392  
 Bos, M.M. 490  
 Bossart, J.L. 486  
 Bostock, R.M. 70  
 Botkin, D.B. 299, 309  
 Boucot, A.J. 220, 231, 310,  
     311, 312, 314,  
     316, 320, 471  
 Boulton, A.J. 464, 465  
 Bowers, M.D. 80, 229  
 Boyce, M.S. 149, 177, 299  
 Boyd, R.S. 64, 66, 78  
 Bozer, S.F. 81–82  
 Bradbear, N. 484  
 Bradley, C.A. 146, 234  
 Bradshaw, J.W.S. 88  
 Bradshaw, W.E. 18, 25, 46, 459  
 Braithwaite, R.W. 169  
 Braschler, B. 47–48  
 Brauman, A. 437  
 Bray, D.P. 499, 501  
 Bray, R.S. 499–500  
 Brazzel, J.R. 482  
 Bredenhand, E. 49  
 Brenes-Arguedas, T. 56  
 Brenner, A.G.F. 306, 449  
 Breshears, D.D. 30, 46, 165, 167,  
     168, 328  
 Brey, P.T. 69  
 Breznak, J.A. 240, 337, 423, 436  
 Briand, F. 269, 273  
 Bridges, J.R. 76, 252, 436  
 Bristow, C.M. 240, 254  
 Broadway, R.M. 78  
 Broderick, N.A. 269  
 Brody, A.K. 286, 448, 450–451  
 Brokaw, N.V.L. 305  
 Bronstein, J.L. 4  
 Brookes, M.H. 170, 492  
 Brosi, B.J. 402  
 Brower, A.V.Z. 116, 137–138  
 Brower, L.P. 61, 66, 73, 106–107,  
     116, 249  
 Brown, B.J. 360, 368–369  
 Brown, J.H. 97, 225, 277,  
     359, 411  
 Brown, M. 385  
 Brown, M.V. 171, 198  
 Brown, S. 335  
 Brown, S.C. 507  
 Brown, V.C. 39, 73, 244  
 Brown, V.K. 299–300, 306, 364,  
     368, 373, 381  
 Bruinsma, M. 9, 54  
 Brys, R. 405, 406  
 Buddle, C.M. 28, 45  
 Buhl, J. 129–130  
 Bullock, S.H. 306  
 Burd, M. 121  
 Burdon, F.J. 272  
 Burger, J.M.S. 122  
 Burkle, L. 407  
 Burney, D.A. 11  
 Burt, A. 497  
 Buteler, M. 494  
 Butler, C.D. 48  
 Byers, J.A. 239  
 Byrd, J.H. 510  
 Calder, I.R. 349  
 Callaway, R.M. 246  
 Cambefort, Y. 423  
 Camilo, G.R. 267, 353  
 Campbell, B.C. 411  
 Canham, C.D. 27  
 Capinera, J.L. 168, 195  
 Cappuccino, N. 171  
 Cárcamo, H.A. 425  
 Cardé, R.T. 85, 102–103,  
     105, 166  
 Cardinale, B.J. 230, 242,  
     245, 348, 459  
 Carlson, J.C. 49  
 Carlton, R.G. 341, 347, 484  
 Carpenter, D. 509  
 Carpenter, S.R. 170, 172,  
     286, 296, 365,  
     368, 373, 375  
 Carrière, Y. 79, 123, 496  
 Carroll, C.R. 373  
 Carroll, G. 56, 63, 248, 255  
 Carson, W.P. 254, 462  
 Carter, G.A. 328, 364  
 Carter, J.L. 280  
 Cartron, J.-L.E. 203, 264  
 Casey, T.M. 33  
 Cates, R.G. 369  
 Cattaneo, M.G. 496  
 Cattânio, J.H. 437  
 Cavalieri, L.F. 178–179  
 Cebrián, J. 368  
 Céréghino, R. 286  
 Cerritos, R. 485, 487, 495  
 Chabot, B.F. 377  
 Chalk, R. 69  
 Chamberlain, K. 247, 249  
 Chambers, J.Q. 328  
 Changnon, S.A. 503  
 Chapin, III, F.S. 50, 70, 75, 365  
 Chapman, C.A. 411, 413  
 Chapman, L.J. 38  
 Chapman, R.F. 32–34, 36–38,  
     42, 55, 87–88, 106, 142, 342  
 Chapman, S.K. 181, 360, 387,  
     390–391, 453, 472  
 Chase, J.M. 29, 243, 286,  
     297, 305, 321, 472–473  
 Chase, T.N. 348  
 Chazdon, R. 392  
 Chen, J. 46, 68, 89, 169,  
     206, 316, 352  
 Chen, Y. 269  
 Chilcutt, C.F. 251, 496  
 Chittka, L. 87, 238, 399,  
     403–404, 407  
 Christensen, K.M. 359, 412  
 Christenson, L.M. 181,  
     203, 269, 364, 374,  
     388–389, 453  
 Cipollini, Jr. D.F. 72  
 Clark, D.B. 377–379

- Clark, J.S. 147  
 Clark, K.L. 353, 385  
 Clark, L.R. 144, 163  
 Clark, W.C. 160, 162, 211  
 Clarke, C.M. 238  
 Classen, A.T. 181, 353, 360,  
 390, 392, 394, 453, 459  
 Claudianos, C. 397, 492  
 Clausen, L.W. 485–486  
 Clay, K. 56, 63, 220, 248  
 Cleary, D.F.R. 27  
 Clements, F.E. 298–299,  
 308, 456  
 Cloe, III, W.W. 228, 332–333  
 Cobb, R.C. 390  
 Cociancich, S. 69  
 Codella, Jr. S.G. 66  
 Coe, M. 411, 413, 423,  
 429, 433  
 Cohen, J.E. 269  
 Colbert, J.J. 178, 181  
 Cole, L. 283–284  
 Colegrave, N. 200, 222  
 Coleman, D.C. 4, 422, 425,  
 431–432, 435, 521  
 Coley, P.D. 70–72, 74, 268,  
 337, 365–366, 368–369,  
 372, 381, 387  
 Collinge, S.K. 203, 282  
 Collins, N.C. 269  
 Collins, N.M. 433  
 Combes, S.A. 100  
 Connell, J.H. 222, 225, 253, 259,  
 283, 298–300,  
 308–309  
 Conner, W.E. 66, 78, 106,  
 114, 228  
 Contarini, M. 509  
 Cook, D.C. 508  
 Cooper, R.A. 485  
 Cooper, S.M. 71  
 Corbet, P.S. 112  
 Corbet, S.A. 404–405  
 Correa, S.B. 410  
 Costa, M.H. 352  
 Costantino, R.F. 178–179  
 Costanza, R. 2, 338, 397, 483, 486,  
 488  
 Côté, M. 411, 417  
 Cotrufo, M.F. 428  
 Couceiro, S.R.M. 11, 39, 45  
 Coulson, R.N. 4, 7, 12, 130,  
 133, 170, 202,  
 211–212, 226, 273  
 Courtney, S.P. 42, 56, 81–83,  
 100, 109, 122, 191  
 Coûteaux, M.M. 244, 471  
 Covich, A.P. 245, 260, 282, 333  
 Cowles, H.C. 298  
 Cowling, R.M. 415  
 Cox-Foster, D.L. 397, 490  
 Coxson, D.S. 430  
 Crane, E. 398, 484–485  
 Crawford, C.S. 35, 37  
 Crawley, M.J. 363–364, 368–369,  
 372–373, 377, 379, 410–412  
 Creelman, R.A. 72  
 Cregg, B.M. 503  
 Croft, B.A. 3, 178, 202, 209,  
 232, 254, 274, 471  
 Cromack, Jr. K. 347, 426, 428,  
 439–440  
 Cromartie, Jr. W.J. 285  
 Cronin, J.T. 71, 145, 153, 190–191,  
 231  
 Crossley, Jr. D.A. 95–96, 269, 329,  
 367, 385, 422, 425–426, 439,  
 446  
 Crutsinger, G.M. 285, 385  
 Cuffney, T.F. 432  
 Culver, D.C. 415, 417, 441  
 Cummins, K.W. 273, 423  
 Cunningham, J.P. 89–90,  
 119–120  
 Currano, E.D. 46–47, 310,  
 312, 316  
 Currie, C.R. 239, 252  
 Currie, D.J. 276  
 Curry, J.P. 31, 39, 153, 182, 261,  
 268, 279, 285  
 Cushing, J.M. 178  
 Cushman, J.H. 240, 251, 254  
  
 Daily, G.C. 2, 338  
 Daly, K.C. 73, 89  
 Dambacher, J.M. 356, 459, 462  
 Dangerfield, J.M. 423, 425, 441  
 Darlington, P.J. 4  
 Darwin, C. 189, 221, 454  
 Dasgupta, P. 483  
 Dauber, J. 405, 441–442  
 Daufresne, T. 347, 357  
 Davidson, D.W. 225, 228, 244, 298,  
 301, 304, 306, 381, 411–412,  
 471  
 Davies, P.E. 204, 209, 507  
 Davis, A.L.V. 421–422  
 Davis, R.L. 89, 121  
 Davis, T.S. 222, 226  
 Davison, E.A. 121  
 Day, J.F. 235, 453  
 Day, M.F. 95, 362  
 Dean, A.M. 178, 241, 254  
 De Carvalho, E.L. 242  
 Dedej, S. 399  
 Deevy, E.S. 150  
 DeFoliart, G.R. 485  
 Degen, B. 398  
 De la Cruz, M. 365  
 Delfosse, E.S. 498  
 Delphin, F. 36  
 De Mazancourt, C. 28, 375, 464  
 DeMers, M.N. 195, 199, 203  
 Demir, E. 121  
 Denlinger, D.L. 31  
 Dennis, B. 178, 180  
 Denno, R.F. 173, 222, 271–272,  
 282, 287, 508  
 Denslow, J.S. 244, 305, 392  
 Denys, C. 494, 522  
 DeRouen, S.M. 235  
 De Ruiter, P.C. 316, 318–320,  
 343, 355–356, 462  
 De Souza-Stevauz, M.C. 410, 416  
 Detling, J.K. 367–368, 373–375  
 Dévai, G. 208, 510  
 Dial, R. 172, 228, 235  
 Diamond, J.M. 4, 236, 285,  
 499, 505  
 Didham, R.K. 405  
 Dik, A.J. 377  
 Dirzo, R. 71  
 Dixon, A.F.G. 37, 81, 84, 87,  
 133, 159, 240, 276  
 Dodds, K.J. 226  
 Doi, H. 284  
 Dolch, R. 73, 247  
 Domisch, T. 441, 448  
 Donald, P.F. 490  
 Dowding, P. 4, 301, 427  
 Downes, J.A. 108  
 Downing, A.L. 465, 470–471  
 Downing, K.B. 487  
 Doyle, R.D. 372–373,  
 498, 509  
 Doyle, T.W. 309  
 Dreisig, H. 238, 240  
 Drew, A.P. 294  
 Drukker, B. 89  
 Drury, W.H. 298, 308–309  
 Dudt, J.F. 75, 244, 281  
 Duffy, J.E. 490, 504  
 Dufrière, M. 267, 510  
 Dukas, R. 89, 92, 121  
 Duncan, D.H. 404  
 Dungan, R.J. 373, 375  
 Dunn, P.E. 31, 69  
 Dunn, R.R. 259, 276–277  
 Dwyer, G. 179  
 Dyer, F.C. 89, 92, 101, 121  
 Dyer, L.A. 70, 119, 276,  
 287–288  
 Dyer, M.I. 364, 373–376

- Edelaar, P. 148, 459  
 Edman, J.D. 4, 236  
 Edmonds, R.L. 308, 425, 427, 434  
 Edmunds, Jr. G.F. 136, 200  
 Edney, E.B. 35  
 Edson, K.M. 234, 239  
 Edwards, C.A. 426–427, 446  
 Edwards, E.P. 37  
 Edwards, J.S. 43, 191, 201, 422  
 Edwards, N.T. 382, 426  
 Edwards, P.J. 75  
 Effler, R.S. 386  
 Eggert, A.-K. 109  
 Eggert, S.L. 82–83, 97, 113, 171, 257  
 Egler, F.E. 298, 299, 304, 308  
 Ehlrlén, J. 411–421, 417  
 Eisner, T. 87  
 Elder, B.D. 30, 160  
 Eldridge, D.J. 343, 422, 441, 444–445, 447  
 Elkins, N.Z. 444  
 Elkinton, J.S. 85, 105  
 Elliott, E.T. 338  
 Elliott, N.C. 37  
 Elser, J.J. 75, 96–97, 347  
 Elton, C. 332  
 Elvidge, C.D. 24  
 Engelberg, J. 454, 461  
 Epstein, W.L. 485  
 Erbilgin, N. 271–272, 498  
 Ernsting, G. 120, 225, 229  
 Erwin, T.L. 276  
 Eshleman, K.N. 392  
 Esper, J. 158–161, 164, 168, 182  
 Espirito-Santo, M.M. 55  
 Evans, E.W. 27, 300, 309, 311, 320  
 Evans, W.G. 44, 166  
 Ewel, J.J. 467, 510, 522  
 Ewers, R.M. 207
- Faeth, S.H. 337, 362, 373, 377  
 Fagen, W.F. 272, 462  
 Fagundes, M. 173  
 Fajer, E.D. 38  
 Fares, Y. 85, 105  
 Fargo, W.S. 178, 181  
 Farmer, E.E. 54, 72–73, 247  
 Farnsworth, N.R. 53  
 Farwig, N. 417  
 Fastie, C.L. 305  
 Feeley, K.J. 375  
 Feener, Jr. D.H. 233  
 Feeny, P.P. 4, 53, 59, 71, 79, 83, 369
- Fei, H. 38  
 Feinsinger, P. 4, 238, 402, 406, 408, 488, 505, 509  
 Felton, G.W. 78  
 Fernandez, D.S. 392  
 Ferrar, P. 421  
 Fewell, J.H. 100, 101  
 Feyereisen, R. 78–79  
 Fielden, L.J. 36  
 Fielding, D.J. 150–151, 202, 273, 510  
 Filip, V. 56, 361–363, 366, 382  
 Finch, V.C. 18–19  
 Fine, P.V.A. 379  
 Finke, D.L. 253, 271, 282, 287  
 Fischer, D.G. 459–460  
 Fischer, R.C. 56, 238  
 Fitzgerald, T.D. 34, 96, 110, 131, 182  
 Flaherty, L. 76  
 Flamm, R.O. 166, 202, 226, 286  
 Fleishman, E. 200  
 Flinn, P.W. 196  
 Florence, L.Z. 136–137  
 Fogel, R. 428  
 Foley, J.A. 6, 24, 49, 207, 328, 349–350, 352–353, 393  
 Foley, P. 166  
 Folgarait, P.J. 100, 233  
 Folz, H.C. 121  
 Fonseca, C.R. 301, 369  
 Fonseca, D.M. 146, 191  
 Fonte, S.J. 83, 181, 364, 386–387, 428  
 Forbush, E.H. 186, 485, 492, 508  
 Ford, C.R. 386  
 Forkner, R.E. 71  
 Forschler, B.T. 37  
 Forup, M.L. 490, 508  
 Fowler, S.V. 54, 247  
 Fox, L.R. 42, 79, 143, 173, 225, 244, 270, 367–368  
 Fox-Dobbs, K. 286, 451  
 Frady, C. 30, 204  
 Fraenkel, G. 55  
 Fraenkel, G.S. 4, 53  
 Frank, D.A. 467–468  
 Frank, S.A. 457  
 Frankie, G.W. 501, 503  
 Franklin, J.F. 46, 133–134, 168, 204, 319  
 French, J.R.J. 239, 436  
 Freymann, B.P. 433  
 Fried, J.H. 199  
 Fritz, R.S. 251, 470  
 Frost, C.J. 181, 364, 374, 385–386, 388, 392, 453
- Frouz, J. 197, 203, 441  
 Fry, S.N. 88, 90  
 Fu, X.-H. 105  
 Fukami, T. 262, 320, 466  
 Fukushima, J. 90  
 Furniss, R.L. 11, 130  
 Futuyama, D.J. 119
- Galatowitsch, M.L. 116, 229  
 Galeas, M.L. 64, 66  
 Galizia, C.G. 407  
 Gandar, M.V. 360–362, 367–368  
 Gange, A.C. 249, 378  
 Ganio, L.M. 213, 215  
 Gannes, L.Z. 269  
 Gara, R.I. 44  
 Gardiner, B. 395  
 Gardner, K.T. 228  
 Garrett, K.A. 469, 494  
 Garretton, M. 306, 448  
 Garrison, R.W. 260  
 Gascoigne, J. 174, 509  
 Gaston, K.J. 276  
 Gate, I.M. 39  
 Gatto, P. 493  
 Gear, A.J. 281, 316  
 Gehring, C.A. 9, 359, 365, 377, 382  
 Genersch, E. 397–398, 490  
 Gering, J.C. 276, 278  
 Ghandi, K.J.K. 27, 30, 507  
 Ghazoul, J. 399, 402  
 Gibbs, A.G. 35–37  
 Gibson, D.J. 364, 381  
 Gibson, R.H. 488, 504–505, 508  
 Gibson, R.W. 56, 63  
 Giebultowicz, J.M. 31  
 Gilbert, M. 212, 214  
 Gillette, N.D. 499  
 Gist, C.S. 97  
 Gleason, H.A. 298, 308  
 Glenn-Lewin, D.C. 299  
 Gliessman, S.R. 494, 522  
 Glynn, C. 70, 73  
 Godfray, H.C.J. 85, 88, 90, 108, 234, 239  
 Goff, M.L. 510  
 Goh, B.S. 238, 240, 246  
 Golden, D.M. 283  
 Goldwasser, L. 270  
 Golley, F.B. 96, 329, 337, 366  
 Gong, Z.-F. 89  
 Gonzalez, M. 316, 318, 320, 427–428, 435  
 Goodisman, M.A.D. 140  
 Gorb, E. 239, 414–415  
 Gordon, D.M. 225

- Goto, S.G. 31  
 Gould, F. 496  
 Gould, J.L. 85, 89, 91–92, 121  
 Gould, S.J. 285  
 Goverde, M. 249  
 Goyer, R.A. 44, 87, 474  
 Grace, J.K. 110, 503  
 Grace, J.R. 386  
 Grant, G.G. 116–117  
 Gratton, C. 204, 508  
 Greathouse, E.A. 504  
 Greenbank, D.O. 146, 163, 182, 195  
 Greenfield, A.B. 485  
 Gressitt, J.L. 239, 329  
 Gribko, L.S. 212  
 Grier, C.C. 387  
 Gries, R. 498  
 Grilli, M.P. 194, 212–213  
 Grimbacher, P.S. 27, 45  
 Grime, J.P. 38, 75, 149–150, 246, 273, 299, 316, 318–319, 332  
 Groot, A.T. 102, 498  
 Gross, I. 69  
 Grove, S.J. 169, 200, 429, 504, 510  
 Gudger, E.W. 485  
 Guillot, F.S. 503  
 Gumbert, A. 407  
 Gunn, D.L. 129, 158, 204  
 Guo, H. 328, 333  
 Guo, Q. 306, 448  
 Gutierrez, A.P. 2, 7, 178, 246  
 Gutiérrez-Ibáñez, C. 89, 121  
 Gutschick, V.P. 45, 50, 328, 336, 347, 386
- Habermann, E. 68  
 Hackstein, J.H.P. 437  
 Haddad, N.M. 29, 199, 203  
 Hadley, K.S. 168  
 Hadley, N.F. 32–33, 35–37  
 Hagen, K.S. 498  
 Haggerty, S.M. 208, 279  
 Haglund, B.M. 81, 167  
 Haimi, J. 427, 433  
 Hain, F.P. 179  
 Haines, B.L. 425  
 Hairston, N.G. 53, 119, 222, 336  
 Hajek, A.E. 234  
 Halaj, J. 225, 271  
 Haldane, J.B.S. 3, 111, 455  
 Hall, M.C. 75  
 Hall, S.R. 269  
 Hambäck, P.A. 87  
 Hamilton, G.R. 53
- Hamilton, W.D. 3, 111, 141, 455, 459  
 Hance, T. 46  
 Hanewinkel, M. 165  
 Hansen Jesse, L.C. 496  
 Hansen, D.M. 505, 509  
 Hanski, I.A. 4, 127, 133, 190, 194, 200, 201, 206, 505  
 Hanson, B. 66  
 Hanula, J.L. 27–28  
 Harborne, J.B. 60–65, 68, 71, 89, 105  
 Hardee, D.D. 481  
 Hardie, J. 31  
 Harding, J.S. 26, 45, 275, 305  
 Hare, J.F. 111, 233  
 Hargrove, W.W. 362–363  
 Harmon, M.E. 425–426, 429, 431, 437  
 Harrel, R.C. 39  
 Harris, L.D. 505  
 Harris, T.W. 491  
 Harrison, S. 9, 171, 173, 200, 201, 246, 505  
 Hart, D.D. 244, 279  
 Hartley, S.E. 63, 76  
 Hassall, M. 498, 505  
 Hassell, M.P. 178, 211, 236, 506  
 Hatcher, P.E. 70, 72, 373, 377  
 Hättenschwiler, S. 432, 435, 465  
 Haukioja, E. 72  
 Havens, K. 271  
 Hawkins, B.A. 277  
 Hawkins, C.P. 273–274, 279, 423, 510  
 Hayes, J.L. 87  
 Haynes, K.J. 133, 147, 191, 192, 195, 198, 207  
 Hazlett, D.L. 260  
 He, F. 43, 282  
 Heartsill-Scalley, T. 28  
 Hedrick, P.W. 133, 136–137, 148, 201  
 Heiermann, J. 162  
 Heinrich, B. 33–35, 87, 99, 100, 120–122, 170, 399, 403, 407  
 Heithaus, E.R. 404, 411, 416  
 Heliövaara, K. 11, 39, 46, 73, 158, 168, 193, 194, 244  
 Helson, J.E. 483, 490  
 Hemmann, D.J. 102, 498  
 Hendrix, P.F. 343  
 Heneghan, L. 429, 435  
 Henne, D.C. 198, 233  
 Herms, D.A. 70, 73  
 Herrera, C.M. 413  
 Herrick, J.E. 433, 443
- Herz, H. 362  
 Herzog, D.C. 415, 417, 441  
 Heuberger, S. 139, 496–497  
 Hicks, W.T. 38  
 Hik, D.S. 364–365, 374–376  
 Hinton, H.E. 37  
 Hirai, H. 136, 200  
 Hirao, T. 28  
 Hirschel, G. 38  
 Hitchner, E.M. 101, 163  
 Hobbie, S.E. 429  
 Hochberg, M.E. 232, 234  
 Hochwender, C.G. 470  
 Hodges, J.D. 81  
 Hodgkinson, I.D. 306  
 Hoehn, P. 490  
 Hoekman, D. 123  
 Hohn, M.E. 212  
 Hokkanen, H.M.T. 494, 498  
 Holdo, R.M. 441, 443, 448, 451, 472  
 Holland, J.N. 242–243, 365, 377, 382–383, 391  
 Hölldobler, B. 110  
 Hollenhorst, S.J. 488  
 Holling, C.S. 5, 120, 225, 229–231, 319  
 Hollinger, D.Y. 386  
 Holopainen, J.K. 54, 75, 97  
 Holter, P. 423, 429, 433  
 Holzschuh, A. 398, 505  
 Honek, A. 411  
 Honkanen, T. 364, 376  
 Hoogendoorn, M. 269  
 Hooker, J.D. 187, 189  
 Hooper, D.U. 316, 318, 465–467, 470–471  
 Hopkins, R.J. 64  
 Horn, H.S. 299, 308–309, 320, 410, 416, 454  
 Horridge, A. 90  
 Horváth, G. 41  
 Horvitz, C.C. 70, 239, 411, 415  
 Horwath, W.R. 425  
 Hossain, F. 45, 49–50, 328  
 Houlihan, J.E. 320  
 Howard, L.O. 481  
 Howe, H.F. 410, 416  
 Hsu, J.-C. 79, 459, 492  
 Huang, C.-Y. 287, 496  
 Huang, F. 54  
 Huberty, A.F. 122  
 Hudgins, J.W. 73, 247  
 Huettl, R.F. 168  
 Huffaker, C.B. 493  
 Hughes, L. 168, 244, 415–417, 425  
 Hughes, R.D. 421–422

- Huhta, V. 427, 436  
Hulme, M.A. 430  
Hulme, P.E. 377, 379, 491  
Hultmark, D. 69  
Hung, C.F. 78  
Hunt, H.W. 267–268  
Hunter, A.F. 46, 254, 348  
Hunter, M.D. 7, 9, 71, 246, 270, 272, 286, 363, 369, 377, 386–387, 392, 426  
Hunter, M.R. 508  
Hunter, W.D. 481  
Huntly, N. 363, 365, 379  
Hurlbert, S.H. 364, 518–519  
Hurny, A.D. 148, 257, 337, 430  
Husseneder, C. 111, 140–141, 455, 503  
Huston, M. 259  
Hutchinson, G.E. 259, 276  
Huxley, C.R. 37, 56, 238
- Ingham, E.R. 427  
Ingham, R.E. 446  
Inouye, B. 242  
Inouye, D.W. 374, 379  
Inouye, R.S. 306, 417, 419  
Irby, W.S. 269  
Irvine, J. 328  
Isaacs, R. 146–147, 153, 397, 488, 490, 494, 498, 522  
Isaev, A.S. 171, 174  
Ishii, Y. 120, 122  
Ishimoto, H. 89  
Istock, C.A. 189, 222, 224, 226  
Ives, A.R. 496  
Iwasaki, T. 120, 229
- Jabłoński, P. 116, 228–229  
Jackson, D.M. 64  
Jackson, R.V. 71, 369  
Jactel, H. 171, 318, 368, 470  
Jandér, K.C. 458–459  
Janssen, R.H.H. 328, 351–353  
Janzen, D.H. 4, 41, 118, 148, 253, 285, 299, 368, 413, 416, 418  
Jarosz, J. 69  
Jeffries, J.M. 285  
Jenkins, M.J. 395  
Jentsch, A. 45, 328, 332  
Jepsen, J.U. 194  
Jepson, P.C. 196  
Jetz, W. 100  
Jhee, E.M. 64, 66  
Joel, D.M. 228  
Joern, A. 75, 97  
Johansson, F. 116, 231
- Johnsen, S. 85, 92  
Johnson, D.M. 32, 41, 162, 194–195, 508, 510  
Johnson, K.A. 425, 433  
Johnson, M.L. 220, 252, 470  
Johnson, M.P. 281–282  
Johnson, M.T.J. 121, 285  
Johnson, R.M. 397–398  
Johnson, S.D. 399, 402–404  
Jolivet, P. 238–239, 251  
Jonas, J.L. 295, 297  
Jøndrup, P.M. 39  
Jones, C.G. 228, 246, 328, 373, 377, 499  
Jones, C.R. 496  
Jones, J.A. 429, 433, 441  
Jones, M.E. 75  
Jonkman, J.C.M. 306, 417, 441, 449  
Jouquet, P. 432, 441  
Juang, J.-Y. 328, 330, 348, 350–352  
Jung, C. 43  
Juniper, B.E. 228  
Jurgensen, M.F. 441, 448
- Käärik, A.A. 305, 309, 427, 430  
Kaczmarek, M. 338  
Kaib, M. 111, 141  
Kainulainen, P. 39  
Kaiser, J. 260  
Kamil, A.C. 83  
Kaplan, I. 72  
Karban, R. 70, 72–73, 78–79, 220, 246, 247, 377  
Kareiva, P. 83, 162, 368  
Karley, A.J. 159  
Kasina, J.M. 488  
Kaushal, S.S. 45  
Kawaguchi, Y. 228, 287, 483, 507  
Kawecki, T.J. 121–122  
Keeling, C.D. 11, 49, 341, 343  
Keeton, W.S. 298  
Kelly, D.J. 40, 244  
Kempston, R.A. 261, 263, 279  
Kennedy, J.S. 43  
Kerridge, A. 485  
Kessler, A. 9, 56, 64, 70, 72–73, 79–81, 85, 220, 249  
Kettlewell, H.B.D. 137, 139  
Key, K.H.L. 33  
Khalil, M.A.K. 437  
Kharboutli, M.S. 35–36  
Kiffney, P.M. 204, 208, 209, 507  
Kiilsgaard, C.W. 348, 386  
Kikkert, D.A. 257–258  
Kim, Y. 33
- Kimberling, D.N. 47  
Kimmins, J.P. 364, 386  
King, A.A. 178  
King, T.J. 306, 448  
Kinn, D.N. 237, 240, 252  
Kinney, K.K. 11, 38, 46, 75, 244  
Kinyamario, J.I. 374  
Kishtawal, C.M. 45, 328  
Kitchell, J.F. 4  
Kitching, R.L. 278  
Kizlinski, M.L. 11  
Klapwijk, M.J. 46  
Klein, A.-M. 397–398, 490, 505–506, 508  
Klein, B.C. 265–266, 470, 510  
Klepzig, K.D. 72  
Klock, G.O. 181  
Kluth, S. 76, 239  
Knapp, A.K. 328, 374, 393  
Knight, T.M. 27, 249, 287, 407  
Knops, J.M.H. 469  
Knorr, M. 429  
Koenig, W.D. 162  
Kogan, M. 3, 5, 7, 100, 109, 122, 209, 246, 307, 491–494, 522  
Kohlmann, B. 423–424, 433  
Kohn, J.R. 402, 404  
Kolb, T.E. 166, 365, 373, 379, 386, 391, 453, 473  
Konishi, M. 158–159, 165, 168, 182, 498  
Koptur, S. 27  
Koren, I. 50  
Koricheva, J. 70, 73, 174  
Körner, C. 273–274  
Koyama, J. 499  
Koyama, Y. 76  
Kozár, F. 163, 194, 204, 222, 278  
Krafft, C.C. 228  
Kramer, A.M. 174, 509  
Kranthi, K.R. 496  
Krantz, G.W. 44, 145, 240  
Kratz, T.K. 319, 462–464  
Krawchuk, M.A. 206  
Kremen, C. 397–398, 488–489, 490, 505, 508  
Kriska, G. 41  
Kruess, A. 168, 244, 282, 506, 522  
Krug, E.C. 6  
Kruger, M. 496  
Kudo, G. 402  
Kurokawa, H. 387, 428  
Kursar, T.A. 490  
Kurz, W.A. 353, 385  
Kytö, M. 75, 347

- Laakso, J. 447, 470  
 Labandeira, C.C. 220, 310–312, 314, 316, 318  
 LaDeau, S.L. 219  
 Lai, L.-C. 68  
 Lake, P.S. 504  
 Lambeets, K. 203  
 Lanciotti, R.S. 219  
 Landis, D.A. 490, 494, 498, 504–505, 522  
 Landsberg, J. 361–362, 368  
 Larsen, T.H. 470  
 Larsson, S. 159  
 Laskowski, R. 431  
 Lavigne, R. 260  
 Law, J.M. 102  
 Lawrence, Jr. W.T. 260  
 Lawrence, R.K. 46, 56, 58, 83  
 Lawton, J.H. 38, 222, 274, 282, 286  
 Leather, S.R. 150, 275  
 Lee, K.E. 429, 433  
 Lee, K.P. 76, 97, 99  
 Lee, K.Y. 31, 69  
 Le Goff, G. 79  
 Leibold, M.A. 278, 465  
 Leigh, E.G. 366  
 Leisnham, P.T. 133, 146, 153, 190, 202  
 Le Mellec, A. 386–388  
 Lenoir, L. 441–442  
 Lent, D.D. 92  
 Leonard, D.E. 146  
 Lerdau, M. 170, 348  
 Leroux, S.J. 287  
 Lesica, P. 306, 415, 441, 443, 448  
 Letourneau, D.K. 172, 287, 296, 471  
 Leuschner, W.A. 178, 181, 488  
 Levins, R. 200, 456  
 Lewsinsohn, T.M. 261, 276, 285, 459, 470  
 Lewis, A.C. 89–90, 119, 166, 403  
 Lewis, O.T. 417  
 Lewis, T. 26, 49, 348–349, 352  
 Lewis, W.J. 90  
 Li, Y.-H. 89  
 Liang, D. 503  
 Liebhold, A.M. 2, 162, 185, 186, 195, 211–212, 499, 509  
 Lill, J.T. 56  
 Lincoln, D.E. 11, 38, 46, 158, 168, 194  
 Lindeman, R.L. 327, 333, 338  
 Lindo, Z. 430–431  
 Lindroth, R.L. 79, 81  
 Linley, J.R. 142  
 Little, D. 72  
 Liu, Z.G. 348  
 Llewellyn, D. 496  
 Llewellyn, M. 362  
 Lloyd, J.E. 105–106  
 Lockwood, J.A. 158, 164, 202, 499, 500, 505  
 Lodge, D.J. 437, 439  
 Logan, J.A. 46, 178–179  
 Logan, J.D. 46  
 Logan, J.G. 501  
 Loomis, W.E. 70  
 Lorch, P.D. 154  
 Loreau, M. 318, 375, 464  
 Lorio, Jr. P.L. 70–71, 73, 167  
 Losey, J.E. 397, 483, 486, 488, 496  
 Lotka, A.J. 143, 177, 230, 333  
 Lou, Y. 72  
 Louda, S.M. 209, 249, 252, 306, 364, 379–380, 411, 416, 498, 504, 509  
 Lounibos, L.P. 195  
 Lovelock, J. 329, 375, 459  
 Lovett, G.M. 364, 375–377, 386–389, 392, 439  
 Lowman, M.D. 71, 361–363, 365–369, 372, 379, 381, 471–473  
 Lowrance, R. 493, 522  
 Lubchenco, J. 259  
 Lugo, A.E. 210, 510  
 Luh, H.-K. 274  
 Lunderstädt, J. 171  
 Lundheim, R. 32–33, 37  
 Lüscher, M. 38  
 Lynch, H.J. 507  
 Lyytikäinen-Saarenmaa, P. 364  
 Ma, S.-C. 158, 168, 182  
 MacArthur, R.H. 4, 148, 259, 281–282, 307  
 Macauley, B.J. 426–427  
 MacDonald, N.W. 392  
 MacEvilly, C. 485  
 MacFadden, B.J. 85–86  
 Mack, R.N. 154  
 MacKenzie, D.I. 150  
 MacMahon, J.A. 4, 19, 273, 299, 306, 308–309, 441, 444, 446, 448  
 Maddrell, S.H.P. 37  
 Madigosky, S.R. 351  
 Madritch, M.D. 390  
 Mafra-Neto, A. 85, 103  
 Magurran, A.E. 259, 261, 263, 285  
 Mahaney, W.C. 306, 441, 443, 483  
 Mahon, R.J. 496  
 Mahunka S. 260  
 Majer, J.D. 275  
 Malausa, T. 139  
 Malcolm, S.B. 73  
 Maleque, M.A. 510  
 Maloney, P.E. 306  
 Malthus, T.R. 170, 221  
 Mankowski, M.E. 76, 252, 425, 427  
 Manley, G.V. 411  
 Manville, R.H. 260  
 Mao, L. 140  
 Mao, W. 78  
 Mao, Y.-B. 54, 78, 497  
 Maraun, M. 436, 439  
 March, J.G. 427  
 Marcot, B.G. 2  
 Marino, P.C. 498, 505  
 Mark, S. 225, 239  
 Marks, S. 46, 168  
 Marquis, R.J. 170, 172, 373  
 Marra, P.P. 4, 236, 453, 499, 509  
 Marron, M.T. 36  
 Marschner, H. 55, 347, 386  
 Martínez, A.J. 373, 378  
 Martínez, N.D. 269, 271  
 Martínez-Mota, R. 411  
 Martin-R, M. 29  
 Martius, C. 437  
 Marvier, M. 496  
 Mascari, T.M. 501–502  
 Maschinski, J. 4, 359, 365  
 Mason, R.R. 143, 159, 162, 182  
 Massonnet, B. 131, 200  
 Masters, G.J. 9, 251  
 Mathias, D. 25, 46  
 Matis, J.H. 178, 211  
 Matsuda, H. 121  
 Matthaei, C.D. 29–30, 195  
 Matthews, R.W. 42–45, 87, 103, 106, 108–110, 112–113, 170, 204, 456  
 Mattson, W.J. 4, 7, 46, 55, 73–74, 87, 159, 163, 165–168, 174, 369, 375, 471, 473  
 Mauricio, R. 358  
 May, R.M. 178, 226, 238, 240–241, 246, 254, 259, 269–270, 276, 318–320  
 Mayer, B. 425  
 Mazza, C.A. 41  
 Mbata, K.J. 485  
 McBrayer, J.F. 76, 423  
 McCann, K.S. 272  
 McCloud, E.S. 72, 247  
 McClure, M.S. 43–44, 379

- McCoy, E.D. 498  
 McCreadie, J.W. 40  
 McCullough, D.G. 78, 109–110, 131, 393  
 McElfresh, J.S. 102  
 McEvoy, P.B. 209, 379, 381, 471, 504, 509  
 McIntosh, R.P. 299, 308  
 McIntyre, N.E. 191  
 McMahan, E.A. 229  
 McNab, B.K. 100  
 McNaughton, S.J. 364–365, 368, 373–375, 377–378, 467, 468  
 McNeill, S. 338  
 Meentemeyer, V. 428, 431  
 Mehdiabadi, N.J. 233, 235  
 Meher-Homji, V.M. 328  
 Mehner, T. 484  
 Meinwald, J. 67–68  
 Meisel, J.E. 32, 198  
 Meisner, M. 87, 252  
 Melander, A.L. 492  
 Meller, V.H. 89  
 Menéndez, R. 510–511  
 Menninger, H.L. 341, 484  
 Menzel, R. 92  
 Merlin, C. 45  
 Merritt, R.W. 499–500  
 Mertl, A.L. 28  
 Mery, F. 122  
 Meyerson, L.A. 509  
 Michalson, E.L. 487  
 Michener, C.D. 110  
 Miles, P.W. 377–378  
 Millennium Ecosystem Assessment, 5, 483  
 Miller, J.C. 80  
 Miller, K.K. 28, 31, 166, 496  
 Miller, S.W. 49, 284  
 Millsbaugh, C.F. 53  
 Minchin, P.R. 264, 267  
 Misra, R. 338  
 Misson, L. 328  
 Mitchell, J.D. 32  
 Mitchell, R. 108, 146  
 Mitchell, R.G. 44, 198  
 Mitchell, R.J. 407  
 Mittelbach, G.G. 285  
 Mittler, T.E. 95, 362  
 Mizutani, M. 362  
 Mock, K.E. 136–137  
 Molano-Flores, B. 504  
 Moldenke, A.R. 402, 404  
 Moll, E.J. 416  
 Momose, K. 398–399, 402, 404–405  
 Mondor, E.B. 38, 138, 244  
 Monteith, J.L. 348, 350  
 Mooney, K.A. 271, 287, 289  
 Moore, A.J. 69  
 Moore, J.C. 4, 8, 34, 267–268, 272, 282, 423  
 Moore, J.R. 330, 395  
 Moore, J.W. 328  
 Moore, R. 368  
 Mopper, S. 28, 71, 73, 136, 138–139, 272  
 Moran, N.A. 87, 246  
 Moran, P.A.P. 162  
 Moran, V.C. 279  
 Moretti, M. 28  
 Morgan, F.D. 4, 239, 436  
 Morishima, I. 69  
 Morón-Ríos, A. 363–364, 368, 377–378  
 Morris, R.F. 4  
 Morrow, P.A. 377  
 Moser, J.C. 4, 252–253, 425, 427–428, 441  
 Moser, S.E. 222, 271  
 Mottern, J.L. 233  
 Muff, P. 280  
 Mumme, R.L. 116, 229  
 Murdock, J.N. 30, 304  
 Murlis, J. 85, 103–104  
 Musser, R.O. 78  
 Mustajärvi, K. 405  
 Mustaparta, H. 84–85, 102  
 Myers, J.H. 160, 174, 499  
 Myers, N. 338  
 Myles, T.G. 69, 141  
 Naeem, S. 189, 355, 466  
 Nakadai, T. 426  
 Nakano, S. 287  
 Namba, T. 4, 485  
 Nansen, C. 328, 364  
 Nardi, J.B. 436, 439  
 Nathan, R. 144, 147, 153  
 Nault, L.R. 4  
 Nealis, V.G. 494  
 Nebeker, T.E. 61, 71–72, 110  
 Nessimian, J.L. 47  
 Neville, P.J. 509  
 Newman, R.M. 71  
 Nicholls, C.I. 492, 494, 522  
 Nichols, E. 504  
 Nicholson, A.J. 4, 171, 236  
 Nielsen, B.O. 367, 378  
 Niemelä, J. 505, 510  
 Niesenbaum, R.A. 75, 244  
 Niwa, C.G. 499  
 Norman, E.M. 400, 403, 405  
 North, M. 454, 476, 490  
 Norton, R.A. 439  
 Nothnagle, P.J. 159  
 Novotný, V. 259, 261, 264, 276, 285  
 Nowlin, W.H. 484  
 Oberrath, R. 415  
 O'Callaghan, M. 496  
 O'Connell, A.M. 426, 430  
 O'Dowd, D.J. 238, 398, 411, 414, 416–417  
 Odum, E.P. 6, 10, 19, 298, 319, 333, 338, 348, 456, 461  
 Odum, H.T. 2, 331, 333, 338–339, 362, 366, 368  
 Oertli, B. 332, 422  
 Oesterheld, M. 378  
 Ohashi, K. 90  
 Ohgushi, T. 142, 171, 220  
 Ohkawara, K. 239  
 Ohmart, C.P. 55, 367  
 Økland, B. 162, 220, 242  
 Oksanen, L. 172  
 Oliveira, P.S. 238, 251, 413, 418  
 Olson, J.S. 426, 431  
 O'Neill, R.V. 7, 318, 329, 356  
 Onstad, D.W. 195, 203  
 Orr, M.R. 233  
 Orwig, D.A. 11, 379, 509  
 Ostfeld, R.S. 299, 306, 321–322, 467  
 Ostrom, P.H. 338  
 Otte, D. 113  
 Ottea, J. 492, 496  
 Owen, D.F. 386  
 Ozaki, M. 140  
 Paige, K.N. 359, 374, 379  
 Paine, R.T. 224, 226, 252, 285  
 Paine, T.D. 166, 369  
 Painter, E.L. 375, 377  
 Painter, R.H. 53, 491, 494  
 Palmer, T.M. 245  
 Palmisano, S. 364  
 Pamilo, P. 140  
 Paoletti, M.G. 430–431  
 Papaj, D.R. 89–90, 123  
 Paquin, P. 27  
 Paradise, C.J. 282  
 Park, T. 4, 222  
 Parker, G.G. 342, 348–351, 392  
 Parker, J. 485  
 Parker, L.W. 441, 449  
 Parker, M.A. 373  
 Parkinson, K.J. 426  
 Parmenter, R.R. 24  
 Parmesan, C. 46

- Parry, D. 80, 170, 172, 188  
 Parsons, G.L. 79, 229, 260  
 Parsons, K.A. 81, 272  
 Parsons, T.J. 72  
 Parton, W.J. 355–357  
 Paschold, A. 71–73, 78  
 Passos, L. 413  
 Patnaik, S. 338  
 Patten, B.C. 10, 353, 461, 462, 463  
 Patten, D.T. 375, 378  
 Payne, J.A. 301, 429, 439  
 Peakall, R. 234, 399–400, 403  
 Pearl, R. 143, 176  
 Pearson, T.R.H. 373  
 Péch, G. 393–394  
 Pedigo, L.P. 373, 375, 483  
 Peet, R.K. 299–300, 308  
 Pemberton, R.W. 485  
 Pérez-Lachaud, G. 271–272  
 Perlman, F. 487, 499  
 Petanidou, T. 403  
 Petelle, M. 386  
 Peterson, J.R. 136, 138  
 Peterson, L.R. 67, 78  
 Peterson, R.K.D. 4, 236, 499–500  
 Petrusewicz, K. 338  
 Phillipson, J. 96, 120  
 Pianka, E.R. 135, 143, 177, 222, 230–231, 252, 254, 454–455  
 Pickett, S.T.A. 259, 299  
 Pielke, R.A. 348  
 Pimentel, D. 508  
 Pimm, S.L. 269–272  
 Pinder, L.C.V. 38–39  
 Plapp, F.W. 79  
 Platt, W.J. 309  
 Pohlman, C.L. 207  
 Poinar, Jr. G.O. 220, 231, 294, 310–316, 453  
 Poland, T.M. 87  
 Polis, G.A. 7, 35, 37, 171, 173, 259–260, 267, 269–273, 275, 279, 285, 295, 329, 355, 462  
 Pollard, A.J. 64  
 Ponsard, S. 269  
 Ponyi, J.E. 208, 510  
 Pope, D.N. 42, 147  
 Porder, S. 328  
 Porter, E.E. 163, 166  
 Porter, S.D. 49, 509  
 Post, D.A. 333  
 Poveda, K. 220  
 Póvoa, M.M. 17, 504  
 Powell, A.H. 205–206, 398, 405–406, 408, 417, 505  
 Power, M.E. 173, 252, 286  
 Prange, H.D. 33  
 Pray, C.L. 287, 484  
 Presley, S.J. 278, 465  
 Pretty, J.N. 494, 522  
 Price, P.W. 2–3, 42, 73, 76, 106, 112–113, 143–144, 151, 153, 159, 162–163, 170, 171, 176–177, 182, 186, 222, 227, 235, 238, 246, 249, 255, 276, 278, 282, 310, 361  
 Priesser, E.L. 159, 165, 168, 172, 174, 244  
 Pringle, C.M. 48, 209, 258, 333, 427  
 Pringle, R.M. 354, 356  
 Pritchard, I.M. 377  
 Procter, W. 260  
 Progar, R.A. 278, 299, 305, 427–428  
 Punttila, P. 207, 300  
 Quesada, M. 304, 306, 373, 406–407  
 Rabatin, S.C. 447  
 Rabb, R.L. 493  
 Rác, V. 182  
 Radeloff, V.C. 206–207, 507  
 Raffa, K.F. 44, 46, 84–85, 87–89, 102–103, 112, 146, 162–164, 328  
 Raich, J.W. 426  
 Raimondo, S. 162  
 Rainey, R.C. 129, 158, 204  
 Ralph, S.G. 72, 459  
 Ramos-Elorduy, J. 4, 485, 495  
 Rand, E.L. 260  
 Rankin, M.A. 41  
 Ranson, H. 501  
 Rasmussen, E.M. 23  
 Rastetter, E.B. 347, 353, 356, 375  
 Raubenheimer, D. 76, 89, 91, 97, 99  
 Raupp, M.J. 501, 503  
 Raven, J.A. 377–378  
 Reagan, D.P.G.R. 226–227, 260, 267, 270–273, 275, 355  
 Reay-Jones, F.P.F. 198, 493–494  
 Regal, R.J. 399, 404  
 Reice, S.R. 29–30, 149, 163, 166, 195, 258, 283  
 Reichle, D.E. 55, 97, 338, 361–362, 367, 378, 439–440  
 Renwick, J.A.A. 64  
 Reusch, T.B.H. 45, 467, 469  
 Reynolds, A.M. 91  
 Reynolds, B.C. 382  
 Rhoades, D.F. 54, 61, 247, 462  
 Ribeiro, S.P. 369  
 Rice, B. 415–417  
 Richardson, B.A. 304, 329  
 Richardson, S.J. 50  
 Richerson, J.V. 267  
 Richter, M.R. 120, 229  
 Ricketts, T.H. 398–399, 405, 407, 505  
 Rickson, F.R. 4, 118, 238, 493, 522  
 Ridsdill-Smith, T.J. 422  
 Ries, L. 207  
 Riley, C.V. 3, 53, 63, 101, 157–158, 163, 185–186, 202, 204, 485, 491–493, 495–496, 498, 508  
 Riley, J.R. 154  
 Risch, A.C. 441, 448  
 Risch, S.J. 84, 285, 494, 522  
 Risley, L.S. 337, 362–363, 372  
 Rissing, S.W. 415–417  
 Ritchie, M.E. 171, 173, 385, 472–473  
 Ritland, D.B. 116  
 Ritter, Jr. H. 113  
 Rivers, D.B. 33  
 Roberds, J.H. 136  
 Robertson, A.I. 411, 417  
 Robinson, M.H. 35, 113, 116  
 Rodgers, H.L. 251, 365, 377–378  
 Rodriguez, J.M. 55  
 Rodriguez-Saona, C. 72, 247  
 Roelofs, W.L. 103  
 Roland, J. 11, 46, 168, 169, 207  
 Romeis, J. 496  
 Romme, W.H. 374, 454, 462, 472  
 Romoser, W.S. 15, 273, 361  
 Root, R.B. 84, 273, 285  
 Rosenheim, J.A. 271–272  
 Rosenthal, G.A. 4, 53  
 Rosenzweig, M.L. 276, 279, 284  
 Rosi-Marshall, E.J. 496  
 Rotem, K. 64  
 Roth, J.P. 422  
 Roth, S.K. 38, 75, 244  
 Roubik, D.W. 399, 402, 404, 408, 410  
 Rousseaux, M.C. 41, 72  
 Roussel, J.S. 482  
 Royama, T. 159–160, 162, 178, 182  
 Ruangpanit, N. 350  
 Rubenstein, D.I. 46, 135, 204  
 Ruberson, J.R. 31  
 Rudd, W.G. 211  
 Rudinsky, J.A. 88–89, 112  
 Ruel, J. 71  
 Running, S.W. 356–357



- Russell, T.L. 501  
 Rykiel, E.J. 178  
 Rykken, J.J. 186, 203–204
- Sabo, J.L. 203, 280, 285, 507  
 Sackville Hamilton, C.A.G. 521  
 Sakai, S. 402  
 Salati, E. 352, 393  
 Salick, J. 441  
 Sallabanks, R. 4, 398, 410, 413  
 Salo, J. 298  
 Salt, D.T. 75, 244, 251  
 Saltzmann, K.D. 76  
 Samways, M.J. 11, 28, 205, 209, 504  
 Sanders, D. 271  
 Sanders, N.J. 11, 437, 438  
 Sanderson, M.G. 437–438  
 Sandlin, E.A. 369  
 Sanson, D.W. 235  
 Santos, P.F. 423, 427, 429–430  
 Šantrůčková, H. 269, 425  
 Sarmiento, J.L. 341, 343, 353  
 Sartwell, C. 28, 42, 198  
 Savage, H.M. 269  
 Savely, Jr. H.E. 301  
 Scatena, F.N. 465  
 Scheiner, S.M. 6  
 Schell, S.P. 130, 159  
 Scheu, S. 269, 436, 439  
 Schiff, H. 85–86  
 Schlesinger, W.H. 207, 352, 379  
 Schmelz, E.A. 61, 72–73, 247  
 Schmidt, D.D. 72  
 Schmidt, J.O. 68, 79  
 Schmitz, O.J. 253, 271  
 Schneider, J.C. 153  
 Schnierla, T.C. 89  
 Schoener, T.W. 222  
 Scholte, E.-J. 501  
 Schöning, C. 140  
 Schöpf, R. 78, 101  
 Schowalter, T.D. 4, 7, 11, 21, 26–28, 30, 41–43, 45, 71, 74–75, 96–98, 112–113, 120–121, 130, 146, 159–160, 162, 165–166, 168, 171–172, 174, 181, 195–198, 206, 208, 244, 252, 267–267, 273–275, 278–281, 286, 293–296, 299–301, 305–308, 309–310, 320–321, 337, 347–348, 361–369, 371–372, 375, 377, 379, 381, 382, 386–387, 390, 392–393, 411–412, 423, 425–428, 431–433, 436–437, 439, 440, 453–454, 461–462, 469–473, 493, 496, 506, 521
- Schroll, H. 338  
 Schultz, J.C. 72–73, 79, 83–84, 100, 115, 118, 147, 171, 226  
 Schulze, E.D. 316  
 Schupp, E.W. 238, 398, 411–413, 417  
 Schütz, M. 417–418, 448–449, 504  
 Schütz, S. 44  
 Schuur, E.A.G. 336, 347  
 Schwachtje, J. 70, 72  
 Schweitzer, J.A. 54, 360, 385, 387, 459–460  
 Scott, A.C. 311, 312, 314, 316  
 Scriber, J.M. 56, 119, 171  
 Sears, M.K. 496  
 Seastedt, T.R. 4, 31, 35, 55, 169, 181, 267, 279, 347, 349, 364, 374–375, 381–382, 386, 422–423, 426–429, 431–432, 435–440, 453  
 Segraves, K.A. 245  
 Sekercioglu, C.H. 207  
 Senthil-Nathan, S. 497  
 Setälä, H. 343, 427, 435–436, 440, 446–448  
 Sexton, J.M. 496  
 Seymour, A.S. 146  
 Sharkey, M.J. 259–260  
 Shaw, D.C. 35, 521  
 Shaw, III, C.G. 175, 493  
 Shaw, P.B. 166  
 Shea, S.R. 415  
 Shelford, V.E. 18, 31, 300  
 Shelton, T.G. 110  
 Sheppard, P.M. 116, 137–138, 488  
 Sherman, R.A. 485  
 Sherratt, T.N. 211, 506  
 Shettleworth, S.J. 89  
 Shonle, I. 64, 80  
 Showler, A.T. 102, 163, 481  
 Shugart, H.H. 309, 320  
 Shure, D.J. 11, 28, 168, 169, 281, 305, 309  
 Shurin, J.B. 286–287  
 Shuster, S.M. 359, 459  
 Siemann, E. 284  
 Siepel, H. 271, 423  
 Siepielski, A.M. 222  
 Sillén-Tullberg, B. 114, 116, 228  
 Silva, S.I. 433  
 Simard, M. 373  
 Simberloff, D.S. 4, 189–190, 273–274, 300, 307  
 Similä, M. 504  
 Simpson, S.J. 76, 97, 99  
 Sims, P.L. 336, 338
- Sinclair, A.R.E. 360, 367–368  
 Sinclair, B.J. 32–33  
 Singh, G. 501  
 Skarmoutsos, G. 377  
 Skellam, J.G. 211  
 Skovmand, O. 501  
 Slansky, Jr. F. 120  
 Smalley, A.E. 4, 95, 329, 338  
 Smedley, S.R. 55  
 Smith, A.A. 458  
 Smith, B.H. 88  
 Smith, C.M. 53, 491, 494  
 Smith, F.R. 448  
 Smith, J.M. 239, 455  
 Smith, J.M.B. 418  
 Smith, J.P. 361, 363, 365, 368  
 Smith, K.F. 18, 500  
 Smith, K.G.V. 510  
 Smith, M.T. 212  
 Smith, R.C. 496  
 Smith, R.H. 158, 481–482, 493  
 Smith, S. 208, 492  
 Smith, W.H. 11, 73  
 Soderlund, D.M. 79  
 Sollins, P. 440  
 Solomon, A.M. 309  
 Somanathan, H. 404, 505  
 Somlyódy, L. 208  
 Song, M.Y. 50  
 Sopow, S.L. 76  
 Sorensen, B.C. 53  
 Soulé, M.E. 190  
 Sousa, W.P. 261, 283, 300, 379  
 Southwick, L.M. 208  
 Southwood, T.R.E. 130, 142–144, 150–151, 275  
 Spaethe, J. 87  
 Spain, A.V. 425–426  
 Speer, J.H. 158–159, 162, 182  
 Spehn, E.M. 465–466, 469–470  
 Spencer, H.J. 199, 203  
 Springett, B.P. 146  
 Srinivasan, M.V. 92  
 Stach, S. 91  
 Stachurski, A. 386  
 Stadler, B. 274, 361–362, 364–365, 369, 382, 386–387, 390, 439  
 Städler, E. 87  
 Stamp, N.E. 70, 73, 88, 90, 119, 143, 173, 229, 244, 249  
 Stanko-Golden, K.M. 440  
 Stanton, M.L. 56, 85–86  
 Stanton, N. 366  
 Stapp, P. 4, 24, 50, 236, 509  
 Starzyk, J.R. 300  
 Steelman, C.D. 4, 235–236

- Steffan-Dewenter, I. 206, 398,  
402–403, 405, 411, 417,  
504–505
- Steidle, J.L.M. 90
- Stephen, F.M. 44, 85, 99, 237,  
301, 305
- Stephens, D.W. 85, 99
- Stermitz, F.R. 71
- Stern, V.M. 101, 163, 492
- Sterner, R.W. 55, 75, 97, 339–340,  
347, 357
- Stevens, M.T. 70
- Stewart, M.M. 228, 504
- Sticher, L. 246–247, 462
- Stige, L.C. 165, 182
- Stiles, J.H. 49, 210
- Stiling, P.D. 173, 259, 261,  
285–286, 362, 373, 377
- Stone, J.E. 166, 507
- Stone, M.K. 32
- Storey, A.W. 275
- Stork, N.E. 279
- Stout, J. 276
- Stout, M.J. 54, 72–73, 247, 497
- Stout, R.J. 387
- St. Pierre, M.J. 133, 145, 147,  
149, 153, 201, 205
- Straub, C.S. 287
- Strauss, S.Y. 64, 70–72, 245
- Streams, F.A. 120, 229
- Strickland, T.C. 440
- Strom, B.L. 44, 87
- Strong, D.R. 159, 173, 209,  
222, 227, 282, 285, 300,  
307, 363
- Strong, W.B. 202
- Sturgeon, K.B. 138
- Suarez, A.V. 11, 28, 49, 154, 170,  
209, 418
- Suarez, M.E. 110
- Summerville, K.S. 28, 49–50, 200,  
205, 278, 282–283
- Swank, W.T. 392
- Swenson, N.G. 100, 131
- Swetnam, T.W. 159, 182
- Swift, M.J. 4, 301, 422, 427
- Sword, M.A. 521
- Symondson, W.O.C. 498
- Szujko-Lacza, J. 260
- Tabashnik, B.E. 139, 496
- Tack, A.J.M. 222–223, 226, 245
- Tahvanainen, J.O. 285
- Taki, H. 398, 505
- Tallamy, D.W. 69, 80, 88, 234, 249
- Tamasi, E. 395
- Tanada, Y. 69, 109, 233–234
- Tanaka, S. 99
- Tanaka, Y. 135
- Tansley, A.G. 329
- Tantawi, T.I. 301–304, 423
- Tayasu, I. 269
- Taylor, S.L. 395
- Teal, J.M. 329, 338
- Temple, S.A. 398, 410, 415, 418
- Terborgh, J. 276, 282, 336, 375
- Thaler, J.S. 64, 72–73, 85, 247–249,  
497
- Theis, N. 403
- Thies, C. 494, 498, 505, 522
- Thomas, C.D. 206
- Thomas, J.A. 11
- Thomas, M.D. 507
- Thompson, D.C. 376
- Thorne, B.L. 141, 455
- Thornhill, R. 106
- Throop, H.L. 75, 347, 357
- Tian, G. 428, 433, 435
- Tilman, D. 238, 242, 251, 259,  
276, 278–279, 284, 316,  
318–319, 466, 468–470
- Tinbergen, L. 170, 228–229
- Tisdale, R.A. 37
- Tobin, P.C. 185–186, 194
- Torchin, M.E. 232
- Torres, J.A. 41, 166, 191, 301, 306,  
369, 372, 381, 473, 508
- Towne, W.F. 85–86, 92
- Townsend, C.R. 83
- Traniello, J.F.A. 88–89
- Traugott, M.S. 73, 90, 143, 173,  
229, 249
- Trenberth, K.E. 328, 330, 351–352
- Treseder, K.K. 347, 387, 392,  
428–429
- Treuhaft, R.N. 328
- Trivers, R.L. 111, 456
- Trilica, M.J. 375
- Trouvelot, L. 185
- Trumble, J.T. 4, 48, 64, 70, 73,  
373–374, 453
- Tscharntke, T. 73, 206, 247, 490,  
494, 498, 522
- Tschinkel, W.R. 140, 427
- Tullis, K. 301, 304, 306, 423
- Tumlinson, J.H. 104, 482, 498
- Tuomi, J. 73
- Turchin, P. 84, 153, 160, 171–172,  
176, 182, 211
- Turgeon, J.J. 83, 228, 411–412
- Turlings, T.C.J. 9, 54, 56, 85, 99,  
143, 249, 462
- Turnbow, R.H. 181
- Turner, D.P. 328
- Turner, G.B. 119
- Turner, M.G. 5, 190
- Turrell, M.J. 220, 499, 509
- Tyler, C.M. 306
- Tylianakis, J.M. 30, 504
- Tyndale-Biscoe, M. 421–422
- Tzean, S.S. 234
- Ulanowicz, R.E. 353, 462
- Urbas, P. 369
- Uvarov, B.P. 129, 158
- Vacas, S. 499
- Valkama, E. 46, 50, 170
- Vamosi, J.C. 407, 488, 490,  
505, 508
- Van Baaren, J. 224
- Van Bael, S.A. 24, 63, 163, 165,  
368–369
- Van Biervliet, O. 504
- Van Cleve, K. 22, 299
- Van Dam, N.M. 71
- Van den Bosch, R. 170, 227–228,  
232, 234, 492
- Van der Maarel, E. 377
- Van der Zee, B. 100
- Van Driesche, R.G. 170,  
227–228, 498
- Van Hook, Jr. R.I. 362
- Van Langevelde, R. 465, 475
- Van Lenteren, J.C. 498
- Vanni, M.J. 286, 376
- Vannote, R.L. 190, 208, 257,  
329, 332
- Van Zandt, P.A. 220, 246
- Vargas, R.I. 499
- Vargo, E.L. 111, 141
- Várkonyi, G. 203
- Varley, G.C. 4, 83, 143, 153, 171,  
179, 182
- Vasconcelos, H.L. 210
- Veblen, T.T. 11, 182, 372, 474
- Via, S. 138
- Vickerman, D.B. 64, 66
- Vincent, C. 494–496, 522
- Vinson, M.R. 276, 280
- Visser, J.H. 56, 254
- Visser, M.E. 46
- Vitousek, P.M. 11, 202, 439, 446,  
465–466
- Vittor, A.Y. 17–18, 50,  
499–500, 504
- Voelckel, C. 73
- Voelz, N.J. 29
- Volney, W.J.A. 369
- Volterra, V. 177, 230
- Von Frisch, K. 89, 92, 101, 121
- Vossbrinck, C.R. 422, 435

- Wäckers, F.L. 91  
 Wagner, D. 441, 444  
 Wagner, D.L. 157–158, 415, 417  
 Wagner, R. 440–441  
 Wagner, T.L. 42  
 Waide, R.B. 276, 279, 284, 335, 465–466  
 Walker, L.R. 10, 26  
 Wallace, A.R. 18, 187, 189, 275, 278  
 Wallace, J. 343, 422–423, 427, 430, 432–433, 440  
 Wallace, J.B. 332, 343, 373  
 Wallin, K.F. 252  
 Wallner, W.E. 209  
 Waloff, N. 182  
 Walter, D.E. 431  
 Walter, J.K. 257  
 Wang, Y. 73  
 Ward, J.V. 32, 34, 38–40, 280  
 Waring, G.L. 73, 75, 347  
 Waring, R.H. 73–74, 167, 212, 328, 335, 355  
 Warren, M.S. 50  
 Wassenaar, L.I. 153–154  
 Waterman, P.G. 71  
 Watson, E.J. 301, 304, 423, 510  
 Watson, M.A. 95, 362  
 Watt, A.D. 38, 46, 75  
 Webb, J.R. 392  
 Webb, W.L. 334–336, 365, 379, 386, 473  
 Weber, N.A. 239  
 Webster, J.R. 6, 319, 332, 341, 462, 464  
 Wedin, D.A. 425  
 Wegener, A.L. 187  
 Wehner, R. 89, 92  
 Wei, C.A. 92  
 Weinstock, G.M. 397  
 Weisser, W.W. 360  
 Wellington, W.G. 4, 41–43  
 Wells, J.D. 304, 306  
 West, D.C. 299  
 Westoby, M. 239, 415–416  
 Weygoldt, P. 300  
 Wheeler, G.S. 437  
 Wheelwright, N.T. 410  
 Whiles, M.R. 135, 341  
 White, G.M. 402, 404  
 White, P.S. 10, 26–27  
 White, P.S. 71, 372  
 White, T.C.R. 73, 182, 473  
 Whitford, W.G. 32, 37, 135, 230, 411, 422, 425, 427–429, 433–434, 441–442  
 Whitham, T.G. 54, 83, 181, 359, 459–460, 472  
 Whittaker, R.H. 54, 299–300, 304, 308, 320, 331–332, 335–337  
 Wickler, W. 87, 98  
 Wickman, B.E. 44, 133, 162, 168, 305, 365, 374  
 Wiegert, R.G. 96, 333, 336, 360, 362, 368  
 Wiens, J.J. 276–277  
 Wiggins, G.B. 40  
 Wikars, L.-O. 27  
 Wiklund, C. 80  
 Wilf, P. 310, 316  
 Willers, J.L. 499  
 Williams, D.W. 50, 133, 163, 168, 204–205, 213  
 Williams, K.S. 230  
 Williams, N.M. 398, 505  
 Williamson, M. 238  
 Williamson, S.C. 364, 373–375, 453, 472  
 Willig, M.R. 26–27, 166, 276, 299, 306, 372  
 Willmer, P.G. 37  
 Wilson, D.S. 56, 454, 456  
 Wilson, E.O. 1–2, 4, 109–112, 189, 259, 275–276, 278, 281, 283, 300, 307, 455  
 Wilson, M.V. 205–206, 504–505  
 Wimp, G.M. 285, 459, 470  
 Winchester, N.N. 423, 431  
 Windsor, D.M. 23–24, 351  
 Winfree, R. 490  
 Wint, G.R.W. 366  
 Winter, C. 505  
 Winter, K. 336  
 Wipfli, M.S. 228, 257, 332–333, 504  
 Wisdom, C.S. 373, 377, 379  
 Wise, D.H. 172, 269, 426, 433  
 Wise, M.J. 82, 242  
 Wissinger, S.A. 286  
 Witcosky, J.J. 28–29, 369  
 Witkamp, M. 329, 425–426, 440  
 Witmer, M.C. 418  
 Wold, E.N. 246  
 Wood, D.M. 303  
 Wood, T.E. 345, 439, 446  
 Wood, T.K. 109–110, 113  
 Woods, P.V. 426  
 Woodwell, F.I. 464–465  
 Woolhouse, H.W. 336  
 Wotton, R.S. 422, 440  
 Wright, L.C. 377  
 Wynne-Edwards, V.C. 111, 455  
 Wystrach, A. 92  
 Xiao, J. 328  
 Yamanaka, T. 174, 499, 509–510, 522  
 Yang, G.-H. 488  
 Yang, M.-X. 34  
 Yang, S. 298  
 Yee, D.A. 149  
 Yen, A.L. 485  
 Yoder, J.A. 37  
 Yodzis, P. 315, 317  
 Yokoyama, K. 439  
 Yorks, T.E. 380  
 Yuan, W. 328  
 Zabel, J. 198  
 Zaidi, R.H. 269  
 Zalucki, M.P. 61  
 Zangerl, A.R. 496  
 Zaragoza, S.R. 448  
 Zavala, J.A. 46, 75  
 Zehnder, C.B. 56–57, 75  
 Zeng, R.S. 247, 250  
 Zenk, M.H. 64, 483  
 Zera, A.J. 99, 119, 121  
 Zeringue, Jr. H.J. 72, 462  
 Zettler, J.A. 49  
 Zhang, J. 328  
 Zhang, Q.-H. 87–88  
 Zhong, H. 159, 280, 301, 308, 423, 425–428, 433, 436  
 Zhou, H.-B. 494, 522  
 Zhou, J. 4, 24–25, 50, 236  
 Zimmerman, J.K. 464–465  
 Zimmerman, P.R. 437  
 Zjhra, M.L. 401  
 Zlotin, R.I. 364, 378, 387

# TAXONOMIC INDEX

---

- Abedus* 109  
Acridoid 113  
*Acromyrmex* 239, 252  
*Aculus schlechtendali* 232  
*Acyrtosiphon pisum* 38, 87, 138, 253  
*Adelges*  
  *cooleyi* 296  
  *tsugae* 44, 380, 386, 509  
*Aechmea mertensii* 286  
*Aedes* 40  
  *albopictus* 195, 219, 509  
  *taeniorhynchus* 50  
*Aeneolamia albofasciata* 29  
*Aeshna juncea* 231  
*Agamemnon iphimeidea* 166  
Agaonidae 312  
*Agapeta zoegana* 246  
*Alabama argillacea* 157  
*Amblyomma gemma* 236  
*Amblyseius andersoni* 232  
*Anagasta kunniella* 112  
*Anagrus sophiae* 145  
Andrenidae 404  
*Anolisomyia*  
  *rufianolis* 235  
  *stratulus* 235  
*Anopheles*  
  *darlingi* 17-18, 50  
  *gambiae* 49  
Ant 48, 70, 100, 146, 154, 173, 238, 245, 286, 382, 414-415, 417, 458  
  army 32, 198  
  carpenter, 140, 301, 503  
  desert 91  
  fire 49, 68, 210, 235, 509  
  funnel 441, 445  
  harvester 121, 199, 225, 229, 416, 441-442  
  leaf-cutter 89, 121, 239, 252, 306, 369, 427, 441, 449  
  slave-making 110-111, 233  
  wood 448  
*Anthocharis cardamines* 41, 80-81  
Anthocoridae 271  
Anthomyiidae 410  
*Anthonomus grandis* 101, 158, 163, 204, 481-482  
Anthophoridae 404  
Ant lion 100  
*Apanteles glomeratus* 120  
*Aphaenogaster*  
  *barbigula* 441  
  *cockerelli* 458  
Aphid 41, 43, 56-57, 75-76, 87, 131, 240, 249  
  alfalfa 87, 253  
  gall 385  
  grey pine 38  
  hickory 312  
  pea 38, 87, 138, 253  
*Aphidius*  
  *avenae* 224  
  *ervi* 225, 253  
  *rhopalosiphi* 224-225  
*Aphis nerii* 56-57, 75  
*Apis* 399  
  *dorsata* 401  
  *mellifera* 86, 101, 382, 397, 399, 408  
*Aradus cinnamomeus* 193  
*Archips*  
  *argyrospilus* 102  
  *cervasivoranus* 102  
  *mortuanus* 102  
  *velutinana* 102  
*Argyrotaenia*  
  *cervasivoranus* 102  
  *velutinana* 102  
Armyworm 66, 72, 247  
*Arthropleura armata* 314  
Asilid 116, 118  
*Asphondylia borrichiae* 174  
*Atta* 239, 252, 503  
  *cephalotes* 88, 369  
  *columbica* 121  
  *laevigata* 210, 449  
  *sexdens* 88  
  *texana* 88-89, 427-428, 441  
  *vollenweideri* 306, 441, 449  
*Attacus atlas* 117  
*Autographa precationis* 122  
*Azteca alpha* 313  
  
Backswimmer 173  
Bark bug 193  
*Battus philenor* 123  
Bed bug 503  
Bee 30, 399, 488-489  
  bumble 34, 87, 90, 100, 407  
  carpenter 404  
  euglossine 106  
  honey 86, 89-90, 101, 382, 397, 399, 408, 488  
  orchard 100  
Beetle 16, 26, 43, 74, 79, 88, 95, 119, 229, 245, 284, 287, 377, 379, 399, 411, 485-486, 503  
  ambrosia 237, 301, 433  
  bark 28, 30, 42-43, 84, 102-103, 112, 131, 165, 202, 212, 225, 239, 434  
  blister 67, 485  
  bombadier 68  
  burying 504-505  
  checkered 153  
  cucumber 80  
  darkling 191  
  Douglas-fir 132  
  dung 109, 240, 415, 421-422, 439, 470  
  engraver 44, 133, 377  
  fir engraver 133  
  flea 64  
  flour 112, 179

- ladybird 45, 67, 133, 142, 503  
 leaf 87, 373  
 mountain pine 138, 168, 204,  
 374, 472  
 potato 101, 163, 204, 491  
 ragwort flea 380, 471  
 root bark 28  
 southern pine 44, 136, 162, 168,  
 172, 196-197, 221, 239,  
 253, 310, 321, 381  
 spruce 11, 71, 393  
*Belostoma* 109  
*Bemisia tabaci* 146  
*Biston betularia* 137  
*Blepharida* 61  
 Bollworm 79  
*Bombus* 100, 121, 407  
   *impatiens* 90  
   *terrestris* 87  
   *vosnesenskii* 34  
*Bombyx mori* 105  
*Botettix argentatus* 115  
*Brachynus* 68  
*Bradysia impatiens* 63  
*Bryobia rubrioculus* 232  
 Budmoth 158, 160-161, 195,  
 295, 362  
 Budworm 42, 56, 58, 64, 133,  
 146, 159, 164, 207, 295,  
 373, 380  
 Buffalo burr 101  
 Buprestidae 43, 424  
 Butterfly 11, 16, 42, 72, 80-81,  
 96, 114, 146, 203, 249  
   cabbage white 64, 66, 90, 120  
   Fender's blue 504-505  
   Glanville fritillary 190  
   monarch 43, 61, 116, 153-154,  
   204, 234  
   speckled wood 113  
   swallowtail 115, 123  
   viceroy 116  
  
 Caddisfly 29, 40, 113, 441  
 Calliphorid 423  
*Callosamia promethea* 202  
*Callosobruchus maculatus*, 108  
*Camponotus*, 301  
   *femoratus*, 286  
   *ocreatus*, 140  
 Carabidae, 505  
*Cataglyphis fortis*, 91  
 Caterpillar, 97, 392, 485  
   black swallowtail, 114  
   range, 98, 200  
   tent, 34, 36, 79, 80, 110, 119, 188,  
   207, 390  
 Centipede, 3  
  
 Cerambycidae, 81, 116, 118, 221,  
 226, 423  
 Ceratopogonidae, 142, 304,  
 312, 314  
*Chelaner*  
   *rothsteini*, 121  
   *whitei*, 121  
 Chigger, 235  
 Chironomidae, 206  
*Choristoneura*  
   *fumiferana*, 56, 146, 159, 380,  
   394  
   *occidentalis*, 43, 133, 295, 373  
*Chrysomela knabi*, 95  
*Chrysoperia*, 271  
*Ciboacris parviceps*, 61  
 Cicada, 33, 135, 162, 230, 485-486  
*Cinara*, 295, 361  
   *pseudotsugae*, 368  
 Cleridae, 287  
 Coccoidea, 291, 295  
*Coccophagus scutellaris*, 232  
*Cocotrypes rhizophorae*, 379  
*Cochliomyia hominivorax*, 499  
*Coenagrion hastulatum*, 231  
 Cockroach, 109, 113, 503  
   Madagascar hissing, 120  
   wood, 110, 113  
 Coleoptera, 40, 48, 109, 112,  
 304, 424  
 Collembola, 431  
 Colletidae, 404  
*Coloradia pandora*, 32, 158  
*Copris*, 109  
*Coptotermes formosanus*, 38, 68,  
 140, 503  
 Coreidae, 410  
 Corixidae, 226  
 Corn borer, 139, 179  
*Cosmosoma myrodora*, 66, 106  
 Crayfish, 244, 423  
*Crematogaster*  
   *sjostedti*, 245  
   *mimosae*, 245  
   *nigriceps*, 245  
 Cricket, 99, 113  
   mole, 106  
   tree, 279  
 Crustacean, 3  
*Cryptocercus*, 314  
*Culex*, 220  
   *pipiens* 219  
   *quinquefasciatus* 219  
   *restuans* 219  
   *tarsalis* 219  
   *antillumagnorum*, 304  
   *Cryptocercus punctulatus*, 110, 113  
 Culicidae, 206  
   *Culicoides barbosai*, 142  
   *Culicoides impunctatus*, 501  
 Cutculionidae, 410  
*Dactylopius coccus* 485  
 Damsel fly 231  
*Danaus plexippus* 44, 61, 116, 153,  
 204, 234  
 Daneidae 116  
*Delphacodes kuscheli* 194, 213  
*Dendroctonus* 28, 43  
   *frontalis* 43, 71, 136, 162, 168,  
   196-197, 239, 253, 321  
   *micans* 212, 214  
   *ponderosae* 136-138, 168, 204,  
   374, 472  
   *pseudotsugae* 132  
   *rufipennis* 11, 393  
 Dermestidae 304, 423  
*Diabrotica undecimpunctata* 80  
*Diceroprocta apache* 33  
*Dioryctria albitella* 71, 390  
*Dioryctria albovitella* 412  
 Diprionidae 66  
 Diptera 41, 139, 317  
*Dipterocarpus* 402  
*Disciphus tammaninii* 269  
*Discomoeus* 40  
*Diurnea flagella* 247  
 Dragonfly 16, 35, 106, 112, 231,  
 286  
*Drepanotermes* 445  
*Drosophila* 36, 69, 143  
   *melanogaster* 89, 122, 138  
   *subobscura* 39, 46, 511  
  
*Eciton burchellii* 32, 198  
*Eleodes obsoleta* 191  
 Empidid 106, 108  
*Eoreuma lofiuni* 198, 494  
*Eotetranychus* 232  
 Ephemeroptera 49, 284  
*Epirrita autumnata* 194  
*Epitrix* 64  
*Eufriesea*  
   *laniventris* 408  
   *xantha* 408  
*Euglossa*  
   *augaspis* 408  
   *chalybeata* 408  
   *crassipunctata* 408  
   *imperialis* 100  
   *iopyrrha* 408  
*Eulaema*  
   *bombiformis* 408  
   *meriana* 408  
   *mocsaryi* 408  
*Euptoieta claudia* 203  
 Eurosta solidaginis 71

- Exaerete frontalis 408  
 Firefly 106  
 Flea 24  
*Fletcherimyia fletcheri* 206  
 Fly 37-38, 63, 203  
   aslid 118  
   black 39, 146, 191  
   blow 485  
   buffalo 421  
   bush 421  
   house 199  
   flesh 33  
   sand 24-25, 314-315, 502  
   sarcophagid 233  
   screwworm 499  
   sweet potato whitefly 146  
*Formica* 140  
   *exigua* 418, 449  
   *exsecta* 417  
   *podzolica* 287, 448  
   *polycytena* 415  
   *rufa* 442  
*Frankliniella occidentalis* 244  
  
*Galerucella* 87  
*Galleria mellonella* 69  
*Geocoris* 271  
 Giant water bugs 109  
*Gilpinia hercyniae* 78  
*Glomeris marginata* 437  
 Glowworm 105  
*Gonimbrasia zambesina* 485  
*Gossypium* 101, 163  
   *hirsutum* 101, 163  
 Grasshopper 32, 61, 113, 150-151,  
   166, 173, 243-244, 249, 311,  
   485, 487  
   creosotebush 115  
   lubber 67  
   Rocky Mountain 158, 164, 202  
   salt marsh 95  
*Gromphadorhina portentosa* 120  
*Gromphadorholaelaps schaeferi*  
   120  
*Gryllotalpa vinae* 106  
 Gryllotalpidae 425  
*Gryllus campestris* 48  
*Gymnopholus* 239  
*Gynanisa maja* 485  
  
*Haematobia irritans* 235, 421  
 Halictidae 404  
*Harpaphe* 68, 79  
   *haydeniana* 425  
 Heliconiid 114, 116  
*Heliconius* 109  
  
*Helicoverpa*  
   *amigera* 269, 497  
   *virescens* 64  
   *zea* 250  
*Heliothis*  
   *subflexa* 102  
   *virescens* 102, 153  
*Hemidiena* 33  
   *maori* 133, 202  
*Hemileuca oliviae* 98, 200  
 Hemiptera, *see* Heteroptera  
*Henosepilachna niponica* 142  
*Hepialus californicus* 244  
*Hesperocorixa lobata* 222, 224, 226  
*Hesperotettix viridis* 373  
*Heterocampa guttivitta* 392  
 Heteroptera 27, 36, 78, 269-270,  
   382  
*Hippodamia convergens* 133  
*Hodotermes mossambicus* 32  
 Homoptera 169, 239-240, 300  
*Hopea* 402  
 Hornfly 235  
 Hornworm, tobacco 73  
*Hyalophora cecropia* 69  
*Hylastes nigrinus* 28  
 Hymenoptera 36, 79, 90-91, 110,  
   116, 140, 143, 232  
*Hymenorus densus* 245  
*Hypoponera* 28  
*Hyposoter exiguae* 247  
*Hypsipyla grandella* 378  
  
*Icaricia icarioides fenderi* 504-505  
 Iceria purchasi 498  
 Inachis io 113  
 Ips 44  
 Isa textula 68  
 Isopod 29  
 Itacoris 295  
  
*Junonia coena* 203  
  
*Kaloterms* 314  
*Kosciuscola* 33  
  
 Lacewing 271  
*Lamponius portoricensis* 166  
*Larrea tridentata* 113, 115  
*Lasius*  
   *fuliginosus* 88  
   *niger* 146  
 Leafhopper 194  
 Leaf miner 223  
 Leafworm 157  
  
*Leoptinotarsa decemlineata* 101,  
   163, 204, 491  
*Lepesoma lecontei* 496  
 Lepidoptera 41, 43, 45, 68-69, 88,  
   159, 244, 369, 378, 510  
*Leptothorax*  
   *duloticus* 111, 233  
   *longispinosus* 233  
 Lice 231, 234  
*Ligurotettix coquilletti* 113  
 Limacodidae 68  
*Limenitis archippus* 116  
*Linepithena humile* 49, 154  
 Locust 158  
   desert 36, 45, 91, 100, 129, 166  
   Rocky Mountain 158  
*Locusta migratoria* 45, 91, 158, 165  
*Longistigma caryae* 312  
*Longitarsus jacobaeae* 380, 471  
*Lophocampa argentata* 33, 392  
*Lucilia* 485  
*Lutzomyia*  
   *longipalpus* 501  
   *verrucarum* 24-25  
 Lygaeidae 410  
*Lygaeus equestris* 116  
*Lymantria dispar* 43, 69, 105, 185-  
   186, 246, 269, 385  
*Lythrum salicaria* 87  
  
*Macrocheles*  
   *glaber* 422  
   *peregrinus* 422  
*Macrolophus caliginosus* 269  
*Macrosiphoniella tanacetaria* 131  
*Macrotermes* 450  
*Magiicada* 135, 162, 230  
*Malacosoma* 34, 36  
   *americana* 119  
   *californicum* 34  
   *disstria* 79, 188, 207, 390  
*Mallos gragalis* 110  
*Manduca sexta* 73  
 Mantidae 207  
*Matsucoccus acalyptus* 390, 394  
 Mayfly 16, 204  
 Mecoptera 106  
*Megacelia scalaris* 48  
 Megachilidae 404  
 Melanophila 424  
 Melanoplus  
   *differentialis* 166  
   *sanguinipes* 75  
   *spretus* 158, 164, 202, 204  
*Melanotrachus boydi* 66  
*Melitaea cinxia* 190  
 Meloidae 67, 485

- Messor* 416  
*Metriocnemus knabi* 206  
*Microplitis croceipes* 91  
Midge 501  
Millipede 3, 68, 425, 437  
Mite 3, 43, 120, 232, 252-253, 398, 422  
  astigmatid 145  
  bee 508  
  European red 254  
  mesostigmatid 44, 146  
  oribatid 431  
  prostigmatid 268, 382, 429  
  spider 72, 202, 271  
  tarsonemid 252-253  
  uropodid 145  
*Modicogrylles confirmatus* 99  
*Monochamus titillator* 222  
*Monomorium pharaonis* 88  
*Monomorium pharaonis* 88  
Mosquito 18, 19, 38, 40, 50, 69, 195, 219-220, 499-501  
  pitcher plant 25, 46, 189  
  tiger 509  
Moth 33, 66, 71, 106, 122, 194, 203, 246, 412  
  black 251  
  cecropia 69  
  cinnabar 471  
  clearwing 116  
  diamondback 139  
  flour 112  
  greater wax 69  
  gypsy 42, 69, 81, 85, 105, 185-186, 205, 210, 246, 269, 385, 500, 508  
  oak 386  
  Pandora 30, 158  
  peppered 137  
  shoot 390  
  silkworm 116  
  tussock 143, 181, 385, 475, 490  
  underwing 487  
  yucca 245  
*Musca*  
  *domestica* 199  
  *vetustissima* 421  
Muscidae 423  
Myrmecolacidae 242  
*Myrmica* 88  
*Myzus persicae* 249  
  
*Nabis alternatus* 272  
*Nasonia vitripennis* 32  
*Nasutitermes* 229  
*Necrophorus americanus* 504  
*Neodiprion*  
  *abietis* 295  
  *fulviceps* 37  
  *sertifer* 365  
*Nephila clavipes* 66  
Neuroptera 79  
Noctuid 116, 123, 203, 207  
*Notonecta hoffmanni* 173, 270  
Nymphalid 116, 235  
  
Ochlerotatus  
  *japonicas* 219  
  *sierrensis* 219  
  *taeniorhynchus* 220  
*Odontotermes* 450  
Oestridae 235  
*Omocestus rufipes* 48  
*Onthophagus lenzii* 439  
*Operophtera brumata* 194  
*Orchelimum fidicinium* 95  
*Orius*  
  *majusculus* 269  
  *tricolor* 271  
*Orgyia*  
  *leucostigma* 385  
  *pseudotsugata* 143, 181, 475, 487  
Orthoptera 67, 112  
*Ostrinia nubilalis* 139, 179  
  
*Pachcondyla goeldii* 286  
*Panonychus ulmi* 254  
*Pantorhytes* 239  
*Papilio*  
  *resphontes* 115  
  *polyxenes* 114  
  *troilus* 203  
*Paraponera clavata* 100-101  
*Pararge aegeria* 113  
*Pardosa* 272  
*Paropsis atomeria* 55, 79  
*Parus major* 116  
Passalidae 110  
*Pectinophora gossypiella* 79  
*Pemphigus* 43  
  *betae* 87, 385  
*Pheidole bicornis* 70, 287  
Phoebi sennae 203  
Phorid 198, 233, 235  
Phryganidia californica 386  
Phyllonorycter 223  
Phyllophaga 377  
Pieris  
  *brassicae* 38, 72  
  *napi* 66  
  *rapae* 64, 72  
Pine bark bug 193  
*Piper cenocladum* 287-288  
*Pissodes strobi* 43  
  
*Pissonatus quadripustulatus* 174  
Planthopper 133, 174, 191, 199, 207, 231  
*Plathemus lydia* 112  
*Platycheilus albopunctata* 47  
Platypodidae 239, 301  
*Plebejus argus* 146  
Plecoptera 41, 49, 284  
*Plutella xylostella* 139, 251  
*Poeciloceros bufonius* 33  
*Pogonomymex* 416, 441  
  *barbatus* 225, 441-442  
  *occidentalis* 100-101, 199  
  *rugosus* 230, 442  
*Polyommatus icarus* 249  
*Polypedilum vanderplancki* 37  
*Praon pequodorum* 253  
*Premolepis henschei* 313  
*Prokelisia* 145, 173  
  *crocea* 133, 145, 191, 199, 207, 231  
  *dolus* 122  
  *marginata* 122  
*Promecognathus* 79  
  *laevissimus* 229  
*Protomognatus americanus* 110, 233  
*Pseudacteon tricuspis* 198, 235  
*Pseudomyrmex* 238  
Psocopteran 307  
*Psorophora* 40  
Psychodidae 304  
*Pyrrhalta nymphaeae* 373  
  
*Quadraspidotus peniciosus* 492  
  
*Reticulitermes flavipes* 69  
*Rhaphomyia nigripes* 108  
*Rhodnius* 37  
*Rhyssomatus lineaticolis* 147, 153  
Rice borer 198, 494  
*Rodolia cardinalis* 498  
*Romalea guttata* 67  
*Ropalosiphum insertum* 76  
  
*Salyavata variegata* 229  
*Samia cynthia* 508  
*Sarcophaga crassipalpi* 32  
Sarcophagidae 206  
Saturniidae 68, 116, 485  
Satyridae 113  
Sawfly 37, 66, 78, 97, 295  
Scale insects 485, 492, 498  
Scarabaeidae 240, 470  
*Schedorhinotermes lamanianus* 111, 141

- Schistocerca gregaria* 36, 45, 100, 129, 166  
*Schizolachnus pineti* 38  
 Sciaridae 317  
 Scolytinae 225  
*Scolytus ventralis* 133  
 Scorpion 35, 68, 131  
 Seed bug 116, 410  
*Semiothisa colorata* 61  
*Sericostoma personatum* 441  
*Shorea* 402  
*Sigara macropala* 222, 224, 226  
 Silkworm 105, 116, 485-486, 508  
 Simuliidae 200  
*Simulium* 40  
     *vittatum* 146, 191  
*Sirex noctulio* 209  
 Siricidae 44  
*Sitobion avenae* 224  
*Smitia atterima* 203  
*Solanum rostratum* 101  
*Solenopsis invicta* 48, 88, 140, 198, 210, 235, 509  
*Sorbaphis chaetosiphon* 76  
*Speyeria mormonia* 96  
*Sphenarium purpurascens* 487  
 Sphingid 116  
 Spider 3, 66, 110, 295, 306-307  
     wolf 243-244, 272  
 Spittlebug 29, 37  
*Spodoptera*  
     *exigua* 66, 247  
     *frugiperda* 72  
 Staphylinidae 312  
 Stinkbug 234  
 Stonefly 30, 41, 204  
 Strepsiptera 242  
*Synuchus impunctatous* 411  
 Syrphidae 38, 116, 304  
 Tachinid 235  
*Tarsobaenus letourneauae* 287-288  
*Tarsonemus ips* 253  
*Technomyrmex albipes* 509  
*Tegeticula cassandra* 245  
*Termitaradus protera* 311  
 Termite 37, 69, 111, 229, 240, 252, 441, 443-445, 447, 450, 455, 503  
     Formosan 38, 68, 140, 503  
     harvester 32  
 Termite bug 311  
*Tetranychus* 271  
     *urticae* 72  
*Tetraponera penzigi* 245  
*Tetrix tenuicornis* 48  
*Thanasimus dubius* 153  
*Therioaphis maculata* 87, 253  
 Thrip 402  
 Tick 236, 321  
 Tipulidae 227  
 Tisheria ekebladella 223  
 Tit 116  
 Tortricid 102  
 Torymidae 410  
*Tramnea lacerta* 286  
*Tribolium* 112  
     *castaneum* 178, 180  
*Trichoplusia ni* 102, 248  
 Trichoptera 40, 49, 113, 284  
 Trigonidae 401  
*Trypodendron lineatum* 237  
*Typhlodromus pyri* 232  
*Tyria jacobaeae* 471  
*Umbonia crassicornis* 109  
  
*Varroa destructor* 398, 508  
*Veromessor* 416  
  
 Walkingstick 166  
 Wasp 30, 88, 90-91, 108, 145, 207, 239, 247  
     fig 313, 458  
     seed 410  
     wood 44, 209  
 Waterboatmen 222, 226  
 Water bug 109, 227  
 Weevil 147, 239, 410  
     bean 108  
     cotton boll 101, 158, 163, 204, 481-482  
     white pine 42  
 Weta 33, 133, 146, 202  
*Wyeomyia* 195  
     *smithii* 25, 46, 189, 206  
  
*Xestia*  
     *fennica* 203  
     *speciosa* 203  
*Xylocopa tenuiscapa* 404  
  
*Zeiraphera*  
     *dianiana* 158, 160-161, 164, 195  
     *hesperiana* 295, 362  
*Zetzellia mali* 232



This page intentionally left blank

# SUBJECT INDEX

---

- Abscission 373, 377, 387  
Acetate 437  
Acetic acid 68  
Acetylcholine 44  
Acidic precipitation 11, 48, 347  
Acoustic signals 87, 89, 106, 112  
Actual evapotranspiration rate (AET) 431  
Adaptation 1-2, 12-13, 402-405, 513-514, 516, 523  
    anthropogenic changes 44-45  
    disturbance response 26-27  
    temperature 29-32  
Adelphoparasitism 232  
ADP 346  
AET, *see* Actual evapotranspiration rate  
Aflatoxins 63  
AFLP, *see* Amplified fragment length polymorphism  
Age, population structure 8, 135  
Aggregated dispersion 131, 133  
Aggregation 38, 69, 106, 108, 110, 131, 133, 164, 198, 211, 228, 403, 503  
Agriculture 4, 6, 397, 398, 406, 411, 433, 437, 446, 515, 522  
A/I, *see* Assimilation efficiency  
Airborne visible and infrared imaging spectrometry (AVIRIS) 328  
Airflow 35, 401, 404  
Albedo 12, 23, 348-350, 515  
Alkaloids 64-65, 67, 106  
Allee effect 135, 174, 509-510  
Allele 402  
Allelopathy 246, 309  
Allylanisol 87  
Altruism 111, 454-457  
Altruistic behavior 111  
Always Defect Strategy 457  
Amino acids  
    analogs in plants 64  
    dietary 76, 81, 239  
    synthesis by plants 345  
Ammonia 238, 331, 340, 344-345, 358, 439  
Amplified fragment length polymorphism (AFLP) 136  
Anaerobiosis 165  
Anal pedicel 145  
Anhydrobiosis 36  
Anthropogenic change 10, 17-18, 44-49, 185-186, 204-211, 305, 325, 328-329, 464, 471-472, 515-518  
Antibiotics 30, 68-69, 234, 252, 400  
Antidiuretic hormone 35  
Appeasement 106, 108  
Ascorbate 78  
Assimilation 54, 59, 61, 95-100, 118-121, 124, 337, 340, 345, 362, 438  
Assimilation efficiency (A/I) 98  
Associative learning 90-91  
Assortative stage, community development 283, 300  
ATP 346  
Autocorrelation 212  
Autoparasitism 232  
Autotroph 5, 279, 331, 340-341, 357, 459  
AVIRIS, *see* Airborne visible and infrared imaging spectrometry  
Bacterivore 268, 423, 429  
Bartonellosis 23-24  
Batesian mimicry 116  
Beeswax 484-485  
Behavior, *see specific behaviors*  
Behavioral Fixity Hypothesis 312, 316  
Benzoquinone 68  
Biodiversity, net primary productivity regulation 465-471  
Biogeochemical cycles  
    carbon cycle 343-344  
    factors affecting 347-348  
    herbivory effects 385-392  
    hydric cycle 342-343  
    nitrogen cycle 344-346  
    overview 339-341  
    pool types 340-341  
    sedimentary cycles 346-347  
Biogeography,  
*see also* Geographic distribution  
    habitat connectivity 203-204  
    overview 186  
    population spatial dynamics  
        anthropogenic effects 204-211  
        expanding populations 194-200  
    metapopulation dynamics 200-203  
    modeling 211-214  
    realms 187  
Biomass 1, 8-10, 96, 160, 169, 173-174, 281, 286-287, 291, 295, 298-299, 325, 328-329, 331-332, 334-338, 340-341, 357, 360, 368, 373, 376-377, 436-440, 464-473, 484, 504, 519  
Biomass pyramid 331-332, 375  
Biome  
    aquatic biome types 22  
    community patterns 278-281  
    definition 18  
    disturbances 24-29

- environmental variation 22-24  
 global distribution 19  
 seasonal variation in  
   temperature and  
   precipitation 20-21, 23  
 Bioprospecting 490  
 Birth rate, *see* Natality  
 Blood meal 142, 220, 502  
 Borer 361  
 Bottom-up regulation, population  
   size 171-173, 286  
 Boundary clumping 278  
 Bray-Curtis Similarity index 264  
 Brillouin index (HB) 262-263  
 Broken stick model 261  
 Bt toxin 79, 139, 251, 421, 496-497  
 Bubonic plague 499  
 Burrowing  
   effects  
   decomposition and  
   mineralization  
   comminution 432-436  
   microbial respiration 436-437  
   mineralization 437-440  
   primary production and  
   vegetation dynamics 446-451  
   soil structure, fertility, and  
   infiltration 440-446  
   functional groups 423-428
- Calcium 347, 439  
 Calcium arsenate 482  
 Calcium carbonate 9, 340-341,  
   353, 347-348, 431, 439  
 Caliche 441  
 CAM, *see* Crussulacean acid  
   metabolism  
 Cannibalism 41, 108-109, 142-143,  
   173, 179-180, 270  
 Cantharidin 67, 485  
 Carbon cycle 343-344  
 Carbon dioxide (CO<sub>2</sub>) 23, 37,  
   48-49, 74-75, 95, 138, 168, 244,  
   336, 340-341, 343-344, 347,  
   426, 437-438, 471  
 Carbon, herbivory effects on flux  
   385, 388, 392  
 Carbon/nutrient balance  
   hypothesis 75  
 Carboxylesterase 67  
 Cardiac glycosides 61  
 Carnivorous plant 227-228, 238  
 Carrion feeder 399, 423  
 Carrying capacity 13, 170-171,  
   175-177, 183, 231, 239, 241,  
   314, 402, 456, 517  
 Cauliflorous species 402
- CCD, *see* Colony collapse disorder  
 Cecropin 69  
 Cellulase 55  
 Cellulose 55, 76, 110, 119, 173,  
   239-240, 337, 423, 429-430,  
   436, 452, 491  
 CENTURY 357  
 Cesium 95, 440  
 Chaos theory 178-179  
 Chemoautotroph 279, 331  
 Chitin synthase inhibitors (CSIs)  
   494  
 Chlordane 427  
 Cholesterol 55  
 Chromium 47, 120  
 Classical conditioning 90  
 Cleptoparasitism 232  
 Climate  
   herbivory effects 392-395  
   modification by vegetation  
   348-353  
 Climate change 1-2, 10-11, 45, 133,  
   163, 168-169, 204-205, 316,  
   327-328, 511, 517  
 Clone 138, 298-299, 456  
 Closest distance rule 78  
 Cluster analysis, comparison of  
   communities 264-265, 267  
 CO<sub>2</sub>, *see* Carbon dioxide  
 Coal 312, 314, 316, 341, 344, 428  
 Coarse comminuter 423  
 Coarse particulate organic matter  
   (CPOM) 430  
 Coccinelline 67  
 Coevolution 253, 278, 476  
 Coexistence 226, 278, 291, 300,  
   307, 401, 517  
 Cognition 92  
 Coherence, landscape pattern 278  
 Colonization 8, 10-11, 13, 41-44,  
   71, 130, 148-149, 155, 167,  
   181, 189-191, 194-203, 205,  
   209, 211, 214, 216, 221, 224-  
   226, 257-258, 359, 377, 405,  
   410, 412-413, 424, 430, 436,  
   439, 452, 459, 466, 473, 505,  
   507, 510-511, 518, 520  
 Colony collapse disorder (CCD)  
   397-398  
 Coloration 34, 61, 98, 114-118,  
   124, 228, 376  
 Combat 111, 113, 124, 225  
 Commensalism 231, 236-237, 243,  
   255, 312  
 Comminution 422-423, 432-436  
 Community  
   descriptive approaches 258-275  
   development stages 283
- diversity versus stability  
 community variable stability  
   320-321  
 components of stability 319-320  
 overview 316-321  
 dynamics  
 overview 293-294  
 short-term change 294-296  
 successional change  
 ecological succession 298  
 factors affecting 304-308  
 models 308-310  
 patterns 299-304  
 functional organization 273-275  
 herbivory effects on dynamics  
   379-385  
 overview 217-218  
 paleoecology 310-316  
 species diversity 259-267  
 species interactions, *see* Species  
   interactions  
 structure 257-291  
 biome and landscape patterns  
   278-281  
 determinants  
 conditions of habitat or  
   resources 284-285  
 habitat area and complexity  
   282-283  
 habitat stability 283  
 species interactions 285-287  
 global patterns 275-278  
 overview 275  
 Compensatory growth, plants  
   374-377  
 Competition  
   evolutionary dynamics 457  
   species interactions 221-226  
 Competitive behavior 111-113  
 Competitive strategy, life history  
   150  
 Component community 8, 258,  
   268, 272, 276  
 Condensation 19-20, 35, 330, 342-  
   343, 351  
 Coniine 64  
 Conservation/restorative ecology  
   504-508  
 Constant connectivity hypothesis  
   271, 284  
 Continental drift hypothesis 187  
 Convection 33, 37, 85-86, 342, 349,  
   352, 503  
 Coprophage 76, 423  
 Courtship, *see* Reproduction  
 CPOM, *see* Coarse particulate  
   organic matter

- Crowding 17, 40-41, 44, 51, 129, 146, 163, 165, 167, 182
- Crussulacean acid metabolism (CAM) 336
- Cry toxins 496
- Cryptic coloration 115-116
- CSIs, *see* Chitin synthase inhibitors
- Cuticle, water balance 34-36
- Cyanide 68
- Cyanogenic glycosides 64-65
- Cybernetic system  
ecosystem homeostasis 461-462  
ecosystem nature 459-460  
net primary productivity regulation  
biodiversity 465-471  
insects 471-476  
properties 460-461  
stability definition 463-465
- Cycasterone 62
- Cytochromes P454 78-79
- DCA, *see* Detrended correspondence analysis
- DDT 492, 501
- Decline, population size 162
- Decomposition,  
*see also* Burrowing; Detrivory  
insect indicators 510-511  
modeling 431  
overview 422-423
- DEET 501
- Defenses  
anti-predator defenses 66-68  
antimicrobial defenses 69  
behavior 113-117  
physical 111  
plant, *see* Plant defenses
- Deforestation 17-18, 23, 48-49, 352, 437, 504
- Degree-day 30-31, 511
- Dehydration, tolerance 35-36
- Deme 127-128, 133, 136-138, 144, 146, 148, 153-155, 162, 166, 200-203, 214, 216, 345-456, 505, 518
- Dendrochronology 182
- Denitrifying bacteria 345
- Density, population 130
- Density-dependent effects,  
population size 163, 170
- Density-independent effects,  
population size 163-170
- Dessication 36
- Detoxification 78-79, 101
- Detrended correspondence analysis (DCA) 266-267
- Detritus 98, 257, 304, 242, 337, 340-341, 422-424, 428, 436-441, 464, 496
- Detrivory  
effects  
decomposition and mineralization  
comminution 432-436  
microbial respiration 436-437  
mineralization 437-440  
primary production and vegetation dynamics 446-451  
soil structure, fertility, and infiltration 440-446  
functional groups 423-428  
spatial and temporal patterns in processing 428-432
- Diapause  
abiotic factor effects 30  
freeze-drying 36
- Digestion 54, 72, 76, 80, 84, 98, 119, 238, 306, 340, 411, 436
- 3,4-Dihydrophenylalanine ( $\text{L-DOPA}$ ) 64-65
- Directed dispersal 43
- Dispersal  
effective dispersal 144, 153  
equation 147  
estimation 153-155  
factors affecting behavior  
crowding 40-41  
habitat and resource conditions 41-42  
life history strategy 40  
nutritional status 41  
flight 146  
mechanisms 42-44, 146  
migration 143-144  
population 131-133  
spread 143  
tendency by species 145-146
- Disturbance  
adaptations 26-27  
anthropogenic disturbances 27  
characterization 26  
combinations 26-27  
environmental change  
comparison 10  
herbivory effects 369, 392-395  
population size effects 164-166  
recovery 29, 166  
succession effects 305  
types 25-26
- Diuretic hormone 36
- Diversity indices, species in a community 261-264
- Domatia 56, 118, 238, 244, 251
- $\text{L-DOPA}$ , *see*  
3,4-Dihydrophenylalanine
- Dopamine 68
- Drought 10, 23, 25-27, 124, 159, 165-166, 16, 244, 293, 295-296, 305, 310, 364, 369-370, 373, 381, 393-394, 467-470, 473-475  
*see also* Disturbance
- Dung  
feeder 399  
management with beetles 421-422
- Ecdysone 61-62
- Ecological equivalence 276
- Ecological stoichiometry 97
- Ecological succession 298
- Ecosystem  
approach to insect ecology 12  
biogeochemical cycling, *see* Biogeochemical cycles  
climate modification 348-353  
complexity 6-7  
cybernetic system nature  
ecosystem homeostasis 461-462  
net primary productivity regulation  
biodiversity 465-471  
insects 471-476  
properties 460-461  
stability definition 463-465  
definition 5  
energy flow  
budget 338-339  
overview 332-333  
primary productivity 334-337  
secondary productivity 337  
insect regulation overview 453-454  
modeling 353-357  
overview 325-329  
regulation 9-10  
self-regulation 454-459, 462  
services  
cultural services 485-488  
provisioning services 483-485  
regulating services 488, 490  
supporting services 488-489  
valuation 490  
structure  
physical structure 330-331  
spatial variability 332-333  
trophic structure 331-332  
structure and function  
overview 5-6  
subsystem hierarchy 7-9

- Ectoparasite 232  
 Edge effect, fragmentation 206-207  
 Egestion 95-97, 120, 337, 357-358, 362  
 El Niño/southern oscillation (ENSO) 22-23, 295  
 Elaisome 239  
 Emeryg 338  
 Encapsulation, cells 69  
 Endemic phase, population size 162  
 Endocytosis 69  
 Endoparasite 232  
 Endophage 307  
 Enemy Release Hypothesis 509  
 Energy budget 96-98  
 Energy flow, *see* Ecosystem  
 ENSO, *see* El Niño/southern oscillation  
 Enthalpy 336  
 Entropy 333  
 Environmental change, versus disturbance 10  
 Environmental disturbance, *see* Disturbance  
 Epidemic 167, 194, 200, 219, 285  
 Epidemiology 193  
 Epinephrine 68, 105, 483  
 Equine encephalitis 499  
 Erosion 11, 208, 218, 297, 328, 340-341, 346, 349-350, 352, 358, 392, 396, 429  
 Esterase 68, 79, 137  
 Ethylene 72-73  
 Evolutionary approach 12  
 stage 283  
 theory 221, 454, 456  
 Exoskeleton, function 15  
 Exploitation competition 224  
 Exponential model, population dynamics 175-176  
 Extinction 8-9, 11, 13, 23, 127-129, 133, 135, 148, 153, 189-190, 202-205, 214, 216, 230, 254, 277, 455-456, 505, 509, 516  
 Extinction threshold 174, 177, 183, 462  
 Eyespot 116, 124  
 Facilitation model, succession 308  
 Farnesene 63  
 Fecundity, estimation 150  
 Feedback loop  
 ecosystem homeostasis 462  
 prospects for study 517  
 Filter feeder 131, 430  
 Filterer 423  
 Fine comminuter 423  
 Fine particulate organic matter (FPOM) 430  
 Fire, *see* Disturbance  
 Fixed proportion rule 78  
 Flight  
 dispersal 146  
 efficiency 99  
 evolution 16  
 Flood, *see* Disturbance  
 FLUXNET 327  
 Folivore 222, 251-252, 280-281, 287-288, 295-296, 359, 361, 363, 368, 371-373, 392-393, 395-396  
 Food web analysis  
 compartmentalization 271-272  
 connectance 271  
 food chain length 270  
 omnivory 272  
 ratio of basal to top species 272-273  
 trophic loops and intraguild predation 270-271  
 Foraging, *see* Resource  
 Foraging theory 83  
 Forest 6, 9, 11, 17-19, 25-27, 29, 31, 42, 44, 46, 48-50, 97, 132-133, 159-160, 168-169, 178, 182-183, 186, 188, 191, 196-199, 203-204, 206-210, 260, 265-266, 279-281, 293-301, 304-306, 309-310, 328-330, 350-353, 368-370, 381, 385-393, 398-402, 404-408, 416-417, 429-433, 462-465, 474-475, 490-491, 493-494, 504, 519-521  
 Forest floor stratum 401  
 FOREST-BGC/BIOME-BGC 357  
 FPOM, *see* Fine particulate organic matter  
 Fragmentation 10, 25, 27, 205-208, 404, 406, 435-436, 504-506  
 Frugivore 361, 410, 423  
 Fungi 2, 4, 8, 36, 56, 63, 69, 72, 234, 237, 239, 248-249, 252-253, 268, 305, 309, 347, 423, 427-430, 432-433, 436-437, 439-441, 447, 501, 520  
 Fungivore 237, 268, 296, 300, 312, 423, 429, 436, 447, 451  
 Furanocoumarins 61  
 Gallery 112, 239, 434, 436, 442, 445  
 Gall-former 55, 69, 71, 76, 301, 361  
 Gas chromatography-mass spectrometry (GC-MS) 53  
 Gatherer 423-424  
 GC-MS, *see* Gas chromatography-mass spectrometry  
 Gene expression 30, 45, 72-75, 78, 496-497  
 Generalist 80  
 pollinator 399  
 Genetic composition, population 136-139  
 Geographic distribution, *see also* Biogeography  
 global patterns 187-188  
 island biogeography 189-190  
 landscape ecology 190-193  
 regional patterns 188-189  
 stream continuum 190-193  
 Geographic information system (GIS) 211, 216, 499, 519  
 Geographic positioning system (GPS) 211  
 Geostatistics 211-212, 216  
 Geranylacetone 501  
 Germination 72, 410, 413, 415-416, 418, 420  
 GIS, *see* Geographic information system  
 Global warming, *see* Climate change  
 Glucosinolates 64-65  
 Glucose oxidase 78  
 Glutathione S-transferase 78  
 Glycerol, water balance regulation 36  
 GPS, *see* Geographic positioning system  
 Grazer 361  
 Gross primary productivity 334  
 Gross production efficiency (P/I) 98  
 Group selection theory 455, 476  
 Growth-differentiation balance hypothesis 70  
 Guild 273-275, 283, 463  
 Gypsum dune 304  
 Habitat  
 community structure  
 determination  
 area and complexity 282-283  
 conditions 284-285  
 habitat stability 283  
 connectivity 203-204  
 Habituation 89

- Haploid 111, 136, 141  
 HB, *see* Brillouin index  
 HEG, *see* Homing endonuclease gene  
 Hemoglobin 37  
 Hemolymph 32, 36-37, 68-69  
 Herbivore optimization hypothesis 375  
 Herbivory  
   complexity of effects on ecosystem structure and function 359-360  
   definition 360  
   effects  
     climate and disturbance regime 392-395  
     community dynamics 379-385  
     plant productivity, survival, and growth form 372-379  
     water and nutrient flux 385-392  
   functional groups 361  
   measurement 361-365  
   spatial and temporal patterns 365-372  
 Heterothermic 31  
 Heterotroph 331  
 Heterozygosity 136-137, 148, 202, 399, 497  
 Histamine 68  
 Home range, insect mass relationship 100  
 Homeotherm 96, 270, 337, 461-462  
 Homing endonuclease gene (HEG) 497  
 Honey 484-485  
 Honeydew 36, 95, 240, 251, 254, 314, 361-362, 382, 386, 396, 449  
 Hormone analogues 58, 61-64, 71, 89  
 Humus 426, 428  
 Hurricane 372  
 Hydric cycle 342-343  
 Hydroquinone 68  
 Hypericin 60  
 Hyperparasite 232  
 Hypopus 145
- IBP, *see* International Biological Programme  
 IFM, *see* Integrated forest management  
 IGRs, *see* Insect growth regulators  
 ILTER, *see* International Long-Term Ecological Research  
 Immigration 141, 144, 152-153, 175, 192, 202
- Imprinting 89-90  
 Inbreeding 111, 133, 136-137, 140, 399, 404  
 Inceptin 72  
 Inclusive fitness 455  
 Indicator species analysis 267  
 Industrial melanism 137  
 Infestation 137, 364, 380, 386, 497  
 Information  
   flow 9  
   processing 84-87  
 Infra-red gas analysis (IRGA) 426  
 Ingestion rate 95  
 Inhibition model, succession 309  
 Innate response 89, 93, 119  
 Insect growth regulators (IGRs) 494-495  
 Integrated forest management (IFM) 491, 493-499  
 Integrated pest management (IPM) 139, 491  
   development of concept 491-493  
   ecological tactics  
     crop and forest pest control 493-499  
     medical and veterinary pest control 499-501  
     urban pest control 501, 503  
   principles 492-493  
 Interaction strength 29, 220, 240, 242, 294, 300, 354-355, 459, 462  
 Interactive stage, community development 283  
 Interdemic selection 456  
 Interference competition 224  
 Intermediate Disturbance Hypothesis 259, 283  
 International Biological Programme (IBP) 338  
 International Long-Term Ecological Research (ILTER) 518  
 Intrinsic rate of increase 175-176, 242  
 Invasive species 508-510  
 IPM, *see* Integrated pest management  
 Ipsdienol 103  
 IRGA, *see* Infra-red gas analysis  
 Irruptive population 159-160, 164, 174, 181, 193, 231, 364, 521, 522
- Island biogeography, *see* Theory of island biogeography  
 Isoprene 61, 348  
 Jaccard index 264  
 Jasmonate 73, 247, 497  
 Juvabione 62  
 Juvenile hormone 61-62
- Keystone species 252, 286  
 Kin selection 455  
 Kriging 212  
 K-strategy, life history 148-149, 176-177
- Land use 1, 4, 11, 18, 45, 48-49, 206, 294, 328, 516, 518  
 Landscape  
   community patterns 278-281  
   ecology 190-193  
   fragmentation, *see* Fragmentation  
 Lava 299, 304  
 Leaching 5, 55, 341, 386-390, 392, 422, 431, 451  
 Learning 89-92, 120-121  
 Legume 64, 375, 416-417  
 Leishmaniasis 501  
 Lek 106, 108, 113  
 Life history strategy, successional stages 299-300  
 Life table analysis 151-152, 363  
 Light  
   overview of effects 39  
   ultraviolet, *see* Ultraviolet radiation  
 Lightning 166-167, 169, 202, 305, 345, 379, 393  
 Lignin 55-56, 59, 72, 332, 337, 428-429, 431, 435-436, 452  
 Litter, *see* Detritus  
 Litterbag 426-427  
 Litterfall 29, 360, 382, 387, 390, 425-426, 433, 440  
 Lloyd's Patchiness Index 211  
 Log normal model, rank abundance 261  
 Logistic model, population dynamics 176  
 Long-Term Ecological Research (LTER) 327, 463, 518  
 Lotka-Volterra equation 177, 226, 242, 256  
 LTER, *see* Long-Term Ecological Research  
 Luminescence 105  
 Lyme disease 321-322

- Magnesium 97, 340, 347, 373, 431  
 Magnetic field 85-86  
 Malaria 17-18, 499  
 Malate 336  
 Malathion 482  
 Malpighian tubules 78  
 Mandibulate 7, 88, 113, 222  
 Mark-recapture 153  
 Marking 112, 124, 153-154, 411  
 Mating, *see* Reproduction  
 Medicagenic acid 60  
 Melezitose 386-387  
 Metabolic theory of ecology  
   97, 277  
 Metamorphosis 16  
 Metapopulation  
   conservation/restorative  
     ecology applications  
       505-506  
   spatial dynamics 200-204  
   structure 133-135  
 Methane 11, 422, 428,  
   437-438, 452  
 Methanogenic bacteria 437  
 Methoprene 494  
 Methoxychlor 427  
 Methyl bromide 307  
 Methyljasmonate 248, 250  
 Methyl parathion 482  
 Microbial respiration 436-437  
 Migration 43-44, 143-144  
 Mimicry 116-117  
 Miner 150, 222-223, 361, 373, 377  
 Mineralization 422, 437-440  
 Models, *see specific models*  
 Moisture 8, 15, 18-20, 30, 37, 49,  
   110, 274, 276, 295, 348-349,  
   351-353, 381, 390, 426-429,  
   431, 503, 520  
 Molting 16, 61  
 Monoculture 11, 162, 171,  
   285, 468  
 Morisita-Horn Index 264  
 Mortality 142-143  
 Mountain range 19-20, 50, 188,  
   392, 514  
 MRPP, *see* Multiple response  
   permutation procedures  
 Müllerian mimicry 116  
 Multiple parasitism 232  
 Multiple response permutation  
   procedures (MRPP) 267  
 Multivariate statistics 2, 264, 280,  
   295  
 Multivoltine species 159  
 Mutation rate 136  
 Mutualism 117-118, 237-242, 459  
 Mycangia 118, 239  
 Mycotoxin 218  
 Myrmecochory 238-239, 411,  
   414-417  
 Myrmecophile 98, 237  
 NAO, *see* North Atlantic  
   Oscillation  
 Naphthalene 68, 427, 431  
 Natality 142, 150  
 National Environmental  
   Observatory Network  
   (NEON) 327, 518  
 Natural selection 12, 83, 189, 247,  
   456, 464, 523  
 Nature reserve 141, 207, 493, 505  
 NDVI, *see* Normalized difference  
   vegetation index  
 Nectar feeder 399, 403  
 Nectary 314  
 NEON, *see* National  
   Environmental Observatory  
   Network  
 Nesting, *see* Reproduction  
 Net primary productivity (NPP)  
   334-337, 373, 464-476  
 Net production efficiency (P/A) 98  
 Niche partitioning 225-226, 253,  
   255, 300  
 Niche-preemption hypothesis 261  
 Nicholson-Bailey model 236  
 Nickel 66-67  
 Nicotine 73  
 Nitrate 331, 345, 358, 392, 415, 439  
 Nitrite 331  
 Nitrogen 439  
   fertilization 55-56  
   herbivory effects on flux 385,  
     387-390, 392  
   limitation 81, 97  
 Nitrogen cycle 344-346  
 Nitrogen dioxide 38, 48  
 Nitrogen fixation 332, 340  
 NMS, *see* Non-metric  
   multidimensional scaling  
 Non-interactive stage, community  
   development 283  
 Non-metric multidimensional  
   scaling (NMS) 267  
 Nordihydroquaiaretic acid 61  
 Normalized difference vegetation  
   index (NDVI) 364  
 North Atlantic Oscillation (NAO)  
   295  
 Noviflumuron 494  
 NPP, *see* Net primary productivity  
 NPV, *see* Nuclear polyhedrosis  
   virus  
 Nuclear polyhedrosis virus (NPV)  
   492, 496  
 Nutrient, *see* Resource; *specific  
   nutrients*  
 Nutritional heterogeneity  
   hypothesis 76-77  
 Observational learning 92  
 Olfaction, resource response 85  
 Omnivory 272, 281, 331, 462  
 Ontogeny 298, 308  
 Operant conditioning 90  
 Opercula 106  
 Ouabain 60  
 Outbreak 5, 10, 11, 23, 29, 42,  
   51, 73, 157-165, 167-170,  
   174, 182-183, 202, 205,  
   207-208, 244-245, 309, 353,  
   369, 372, 379-380, 392, 395,  
   454, 472-476, 483, 487,  
   490, 492, 507, 512-513,  
   516-518, 522  
 Overcompensation  
   hypothesis 375  
 Overgrazing 25, 206, 325, 379, 436  
 Overstory stratum 401  
 Oviposition 39, 41-42, 72, 80-82,  
   88, 106-109, 10, 123-124, 142,  
   171, 173, 190-191, 225, 318,  
   514  
 Oxygen supply 37  
 Ozone 38, 49, 138, 244, 336  
 P/A, *see* Net production efficiency  
 P/I, *see* Gross production  
   efficiency  
 Paleocene-Eocene thermal  
   maximum (PETM) 45-46  
 Paleoecology 310-316  
 Palmer Drought Stress Index  
   (PDI) 295  
 PAR, *see* Photosynthetically-  
   active radiation  
 Parasitism  
   integrated pest  
     management 498  
   overview 231-236  
 Parasitoidism 227, 231, 255  
 Parental investment 107, 109  
 Parthenogenesis 135-136, 146  
 Patch 6-8, 26, 28, 31, 41, 51, 83-86,  
   128, 130-131, 133, 145-148,  
   155, 169, 190-195, 198-203,  
   205-208, 210-211, 214, 216,  
   257-258, 271-272, 281-282,  
   321, 327, 333, 464-465, 498-  
   499, 505, 507, 521

- Pathogen 59, 69, 72, 110, 160, 162, 168, 179, 205, 209-210, 236, 247, 249, 251, 314, 373, 377, 485, 491-492, 494, 496, 500-501, 509
- Paving 44, 205, 444-447
- PCA, *see* Principal components analysis
- PDI, *see* Palmer Drought Stress Index
- Peak, population size 162
- Pearl-Verhulst equation 176
- Pedogenesis
- detrivory and burrowing effects
  - decomposition and mineralization
  - comminution 432-436
  - microbial respiration 436-437
  - mineralization 437-440
  - primary production and vegetation dynamics 446-451
  - soil structure, fertility, and infiltration 440-446
  - spatial and temporal patterns in soil processing 428-432
- Pesticide 45, 48, 139, 338, 397-398, 491-492, 503, 506, 522
- Pesticide resistance 139
- PET, *see* Potential evapotranspiration
- PETM, *see* Paleocene-Eocene thermal maximum
- pH
- gut 79
  - nests in soil 441-442
  - soil and water 38, 48
- Phagostimulant 64, 80, 88
- Pheromones
- alarm 117
  - ants 88-89
  - bark beetle 103
  - boll weevil 482
  - competition 112
  - diffusion from plant source 104
  - integrated pest management 498-499
  - sex 102-105
- Phoretic dispersal 42-43
- Phospholipase 68
- Phosphorus 346-347, 386, 439, 446-447
- cycling 346-347
- Photo-oxidation 422
- Photochemical resistance index (PRI) 364
- Photoperiod 24, 30, 45, 189
- Photosynthesis 335-336, 376
- Photosynthetically-active radiation (PAR) 336
- Phytophage 128, 307, 387, 471-473, 475-476, 513
- Phytoplankton 336, 368, 376
- Phytotelemata 38, 149, 304, 329
- Pinene 103
- Pitch flow 61, 71
- Plant defenses
- chemical
  - elemental 64, 66
  - nitrogenous 64-65
  - non-nitrogenous 58-64
  - factors affecting expression 73-75
  - injury response 72-73
  - physical 56
  - species interaction impact 246-250
  - temporal changes 71-72
- Plant stress hypothesis 73-74
- Plant vigor hypothesis 73-74
- Plate tectonics 188
- Poisson distribution 131
- Pollen 4, 81, 90, 295-296, 314, 316, 397, 399-400, 402-405, 458, 489, 496, 508
- Pollen feeder 399
- Pollination
- consequences of decline 397-398
  - effects 405-410
  - functional groups 399-402
  - measurement 402-403
  - overview 398-399
  - services 488-489
  - spatial and temporal patterns 403-404
- Pollution, *see specific pollutants*
- Polygyny 140
- Polymorphisms 136-138, 140
- Polyphagy 138, 173, 316
- Population
- definition 127
  - dynamics 157-183
  - fluctuation 158-163
  - life history 148-150
  - modeling
  - complex models 176-178
  - computerized models 178-179
  - evaluation 179-182
  - exponential model 175-176
  - logistic model 176
  - spatial dynamics 211-214
  - parameter estimation 150-155
  - processes 141-148
  - size, factors affecting 163-174
  - spatial dynamics 193-203
  - structure 130-141
- Potassium 439-440
- Potential evapotranspiration (PET) 336
- Precipitation, seasonal variation in biomes 20-21, 23
- Preconene 62
- Predation
- intraguild predation 270-271
  - modeling 231
  - population regulation 172-173
  - seed, *see* Seed predation
  - species interactions 226-231
  - succession effects 306-307
- PRI, *see* Photochemical resistance index
- Primary parasite 232
- Primary productivity, *see* Gross primary productivity
- see also* Net primary productivity
- Primary succession 299
- Principal components analysis (PCA) 266-267
- Prisoner's Dilemma 456-457
- Production:respiration ratio 463
- Progeny 41, 455, 459
- Prostaglandins 79
- Protease inhibitors 78
- Protein, human diet from insects 485
- Pruning 242, 364, 379, 395, 453, 472
- Pyrethroids 63, 501, 491-492
- Quinones 60-61
- Random dispersion 42, 131-133, 146, 155
- Rank-abundance curve 261-264, 289
- Raster method 211
- RDA, *see* Redundancy analysis
- Reciprocal altruism 456
- Recreational services 485-486
- Redundancy analysis (RDA) 47
- Relay floristics, succession 308
- Release phase, population size 162
- Release threshold, population size 162, 174
- Reproduction
- attraction 102-106
  - courtship behavior 106-107
  - nesting and brood care 109-111
  - oviposition behavior 108-109
- Resilience, community stability 319



- Resistance, community stability 319
- Resource
- acquisition 53-93
  - allocation 95-125
  - attraction 102-106
  - courtship behavior 106
  - foraging and dispersal behavior 98-102
  - mating activity 102
  - reproductive and social behavior
    - competitive behavior 111-113
    - defensive behavior 113-117
    - mutualistic behavior 117-118
    - nesting and brood care 109-111
  - oviposition 108-109
  - availability
  - discovery 83
  - learning 89-91
  - orientation
    - conspecific insect attraction 88-89
  - information processing 84-85
  - responses to cues 85-88
    - budget 96-98
    - efficiency of use
    - factors affecting
    - food quality 119
    - learning 120-121
    - size and physiological condition 120
  - overview 118-119
  - trade-offs 121-124
  - quality
    - requirements 55
    - variation
  - exploitation mechanisms 75-79
  - food quality 55-56, 70
  - injury response effects 72-73
  - plants and tissues 71
  - temporal changes 71-72
- Resource concentration
  - hypothesis 83, 171-172
- Respiration 5, 36-37, 95-98, 124-125, 333-334, 337-338, 341, 343, 357, 374, 382-383, 426, 436-437, 440, 471
- Restorative ecology, *see* Conservation/restorative ecology
- Reward 90, 401-407, 456-457
- Riparian corridor 204, 507
- Rivalry song 112
- r-K model, life history 149
- RNA interference (RNAi) 496-497
- RNAi, *see* RNA interference
- Road, *see* Paving
- Root-feeder 361
- r-strategy, life history 148-149, 176-177, 308
- Ruderal strategy, life history 150, 201, 205, 306, 322, 336, 518
- Runoff 23, 208, 343, 345, 347, 349-350, 444-445, 507
- Salicylic acid 250
- Saliva 76, 67, 364-365, 374, 377
- Sampling 93, 131, 150, 155-156, 194, 196, 213, 216, 267, 275, 463, 518, 520
- Sap-sucker 361-362, 372
- Saponin 61
- Saprotroph 301
- Satiation 143, 170, 230, 412
- Scavenger 300
- Scent glands 102, 112
- Scope, insect ecology 3-5
- Scraper 106, 257, 423, 428, 430, 451
- Search image 120, 122
- Secondary production 270, 327, 331, 337-338, 341, 430, 464
- Secondary succession 299
- Sedimentary cycles 346-347
- Seed bank 305, 308, 418, 467
- Seed cacher 411
- Seed dispersal
  - effects 417-420
  - functional groups of dispersers 410-411
  - measurement 411-416
  - spatial and temporal patterns 416-417
- Seedling 38, 227, 306, 373, 377, 379, 388, 399, 410, 413, 415-417, 420, 446-448, 507
- Seed predation
  - effects 417-420
  - functional groups 410-411
  - measurement 411-416
  - predator 361
  - spatial and temporal patterns 416-417
- Seed vector 411
- Seismic activity 188
- Selenium 66-67
- Senescence 55, 87, 142, 159-160, 306, 323, 347, 386-387, 390
- Sequestration 9, 78, 143
- Sere 298-299, 306, 308, 381, 474
- Serpentine soil 20, 286, 304, 323
- Sex ratio, population 135-136
- Shannon-Wiener index 261-262
- Shellac 485
- Shredder 257, 274, 423, 429-430, 432, 440, 451
- SI, *see* Stress index
- Sibling species 39, 102, 111, 498
- Silk 485
- Simpson index 262-263
- Sinigrin 65
- SIR, *see* Sterile insect release
- SLOSS rule 505
- Smoke 43, 48-49, 165
- Social insects, population structure 139-141
- Social organization 3, 109
- Social parasitism 233
- Sodalime 95, 426
- Sodium 439-440
- Soil
  - detrivory and burrowing effects
    - on structure, fertility, and infiltration 440-446
  - formation, *see* Pedogenesis
  - insect supporting services 488
- Solanine 64
- Solar flare 23
- Sooty mold 36, 249, 251
- Sorenson index 264
- Specialist 80
- Specialist pollinator 399
- Species
  - diversity in community 259-267
  - packing 283, 291, 321, 466
  - richness 189, 204, 259, 261-262, 271, 276-285, 289-291, 300, 307, 318, 321-322, 381, 407, 417, 469-470, 506
  - richness and functional group composition 281
  - turnover 278
- Species interactions
  - classes
  - competition 221-226
  - predation 226-231
  - symbiosis
  - commensalism 236-237
  - mutualism 237-242
  - parasitism 231-236
  - community
    - characterization 267-270
    - structure determination 285-287
    - consequences
    - community regulation 254-255
    - population regulation 254
    - factors affecting
      - abiotic conditions 243

- indirect effects of other species 245-253
- resource availability and distribution 244-245
- food web analysis
- compartmentalization 271-272
- connectance 271
- food chain length 270
- omnivory 272
- ratio of basal to top species 272-273
- trophic loops and intraguild predation 270-271
- paleoecology 310-316
- prospects for study 517
- Sperm competition 113
- Sporothecae 253
- Spread, dispersal 143
- Starvation 228
- Starch 38, 377-378, 386
- Sterile insect release (SIR) 499, 509-510
- Storm, *see* Disturbance
- Stream
  - channelization 168, 208-209, 338
  - habitat types 257-258
  - impoundment 31, 44, 48, 208-209, 338
- Stream Continuum Concept 190-193, 332-333
- Stress index (SI) 364
- Stress-adapted strategy, life history 150
- Stridulation 89, 93, 102, 106, 112-113
- Strontium 96
- Subcommunity 268, 271
- Subpopulation 127, 138, 188, 202
- Subterranean nester 424
- Succession
  - ecological succession 298
  - factors affecting 304-308
  - models 308-310
  - overview 297-299
  - patterns 299-304
- Sulfur 440
- Sulfur dioxide 38
- Sunspot 113, 162
- Superparasitism 232
- Survival rate 143
- Survivorship curve 143-144, 153
- Symbiosis
  - commensalism 236-237
  - mutualism 237-242
  - parasitism 231-236
- TAMBEETLE model 181
- Tannins 59-60
- Taylor's Power Law 211
- Temperature,
  - see also* Thermoregulation
  - adaptation 29-32
  - gradients 33
  - paleontological data 45
  - seasonal variation in biomes 20-21, 23
- Termitophile 237
- Terpenoids 60-61, 67
- Territoriality 112-113, 172
- Tetradecenyl acetate 102
- Theory of island biogeography 189-190, 282, 505
- Thermoregulation 31-33, 51, 98, 121, 170, 403
- Throughfall 342, 381-382, 386-387
- Tit-for-Tat 457
- Tolerance model, succession 308-309
- Top-down regulation, population size 171-172, 173, 286
- Transgenic crops 496
- Transport, anthropogenic 209-211
- Trap cropping 494
- Tree-by-tree replacement model, succession 309
- Trehalose, water balance regulation 36
- Trophic cascade hypothesis 171-172, 286-287, 290
- TWINSpan 280
- Typhus 499
- Tyrosinase 64
- Ultraviolet
  - cues 87
  - radiation 39-40, 59
- Understory stratum 401
- Uniform dispersion 131
- Valuation, ecosystem services 490
- Vector method 211
- Venom 68, 79
- Verbenol 103
- Verbenone 103
- Vernal pool 145, 269
- Vision 112
- Vitamins 55, 76, 79, 239, 430
- Volcanism 38, 166, 188, 323, 333, 345
- Water
  - balance 34-37
  - dispersal
  - insects 42
  - seeds 413
  - flow 38-39
  - herbivory effects on flux 385-392
  - hydric cycle 342-343
  - insect indicators 510
- Watershed 5-6, 160, 190-191, 193, 208-209, 212, 215, 217, 297, 329, 332, 464-465, 483, 519
- Weathering 5, 55, 340, 346
- West Nile virus (WNV) 219-220, 499
- Wind
  - dispersal of insects 42
  - pollination 402-403
  - seed dispersal 413
- WNV, *see* West Nile virus
- Woody debris 168, 169, 257, 301, 422, 425, 436
- Xylophage 423, 427, 504-505
- Zinc 66

This page intentionally left blank